



5-phase stepping motor

86mm cir.

103H858□-6□□□
CE marked
0.72/step



●Applicable drivers



Specifications

Model number		Holding torque at 5-phase energization	Rated current	Wiring resistance	Wiring inductance	Rotor inertia	Weight
Single-axis	Dual-axis	N.m or more	A/phase	Ω/phase	mH/phase	x 10 ⁻⁴ kg·m ²	kg
103H8581-6050	-6020	2.06	0.75	5.7	25	1.45	1.5
103H8581-6250	-6220	2.06	1.5	1.5	5.6	1.45	1.5
103H8582-6050	-6020	4.02	0.75	8.6	41	2.9	2.5
103H8582-6250	-6220	4.02	1.5	2	10.6	2.9	2.5
103H8583-6050	-6020	6.17	0.75	10.5	59	4.4	3.5
103H8583-6250	-6220	6.17	1.5	2.5	15	4.4	3.5

Dimensions (unit: mm)

103H8581-6050/6250 (Single shaft)
103H8581-6020/6220 (Double shaft)

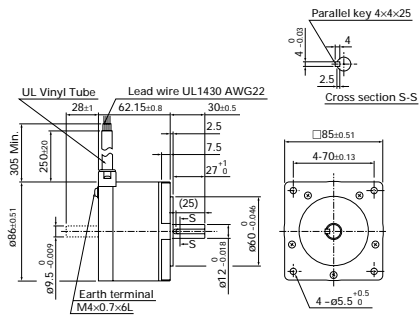

103H8582-6050/6250 (Single shaft)
103H8582-6020/6220 (Double shaft)

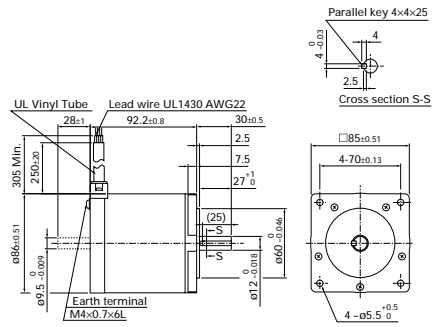

103H8583-6050/6250 (Single shaft)
103H8583-6020/6220 (Double shaft)

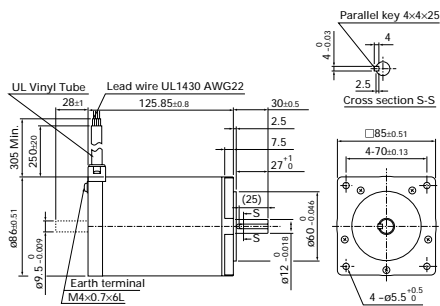

Pulse rate-torque characteristics

●103H8581-6050

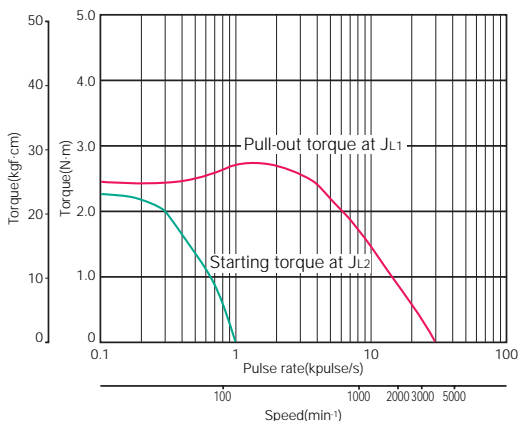

Sanyo constant current circuit
 Source voltage : 100V AC · Winding current : 0.75A/phase
 5-phase excitation (Full step)
 $J_{L1}=7.4 \times 10^{-4} \text{kg} \cdot \text{m}^2$ (With rubber coupling)
 $J_{L2}=1.45 \times 10^{-4} \text{kg} \cdot \text{m}^2$ (Pulley balancer system)

●103H8581-6250

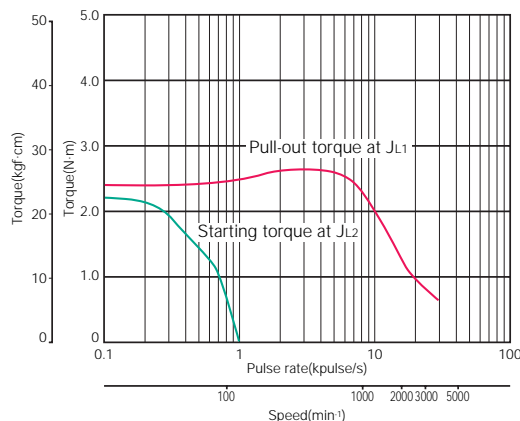

Sanyo constant current circuit
 Source voltage : 100V AC · Winding current : 1.5A/phase
 5-phase excitation (Full step)
 $J_{L1}=7.4 \times 10^{-4} \text{kg} \cdot \text{m}^2$ (With rubber coupling)
 $J_{L2}=1.45 \times 10^{-4} \text{kg} \cdot \text{m}^2$ (Pulley balancer system)

●103H8582-6050

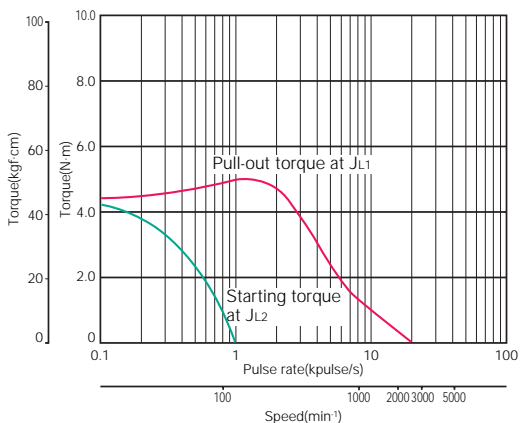

Sanyo constant current circuit
 Source voltage : 100V AC · Winding current : 0.75A/phase
 5-phase excitation (Full step)
 $J_{L1}=15.3 \times 10^{-4} \text{kg} \cdot \text{m}^2$ (With rubber coupling)
 $J_{L2}=2.9 \times 10^{-4} \text{kg} \cdot \text{m}^2$ (Pulley balancer system)

●103H8582-6250

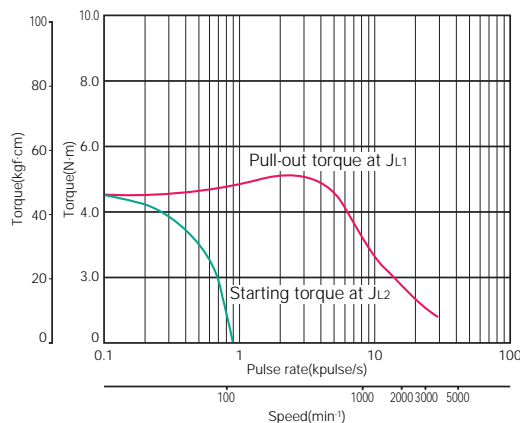

Sanyo constant current circuit
 Source voltage : 100V AC · Winding current : 1.5A/phase
 5-phase excitation (Full step)
 $J_{L1}=15.3 \times 10^{-4} \text{kg} \cdot \text{m}^2$ (With rubber coupling)
 $J_{L2}=2.9 \times 10^{-4} \text{kg} \cdot \text{m}^2$ (Pulley balancer system)

●103H8583-6050

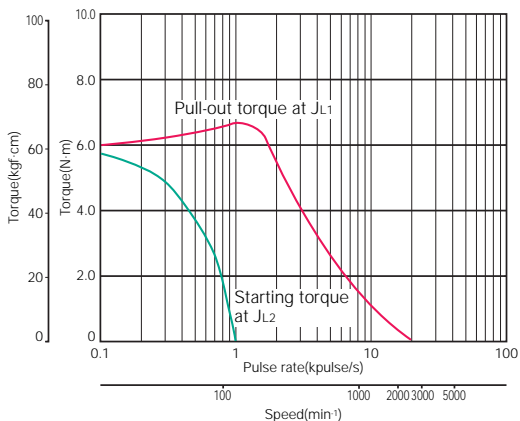

Sanyo constant current circuit
 Source voltage : 100V AC · Winding current : 0.75A/phase
 5-phase excitation (Full step)
 $J_{L1}=43 \times 10^{-4} \text{kg} \cdot \text{m}^2$ (With rubber coupling)
 $J_{L2}=4.4 \times 10^{-4} \text{kg} \cdot \text{m}^2$ (Pulley balancer system)

●103H8583-6250

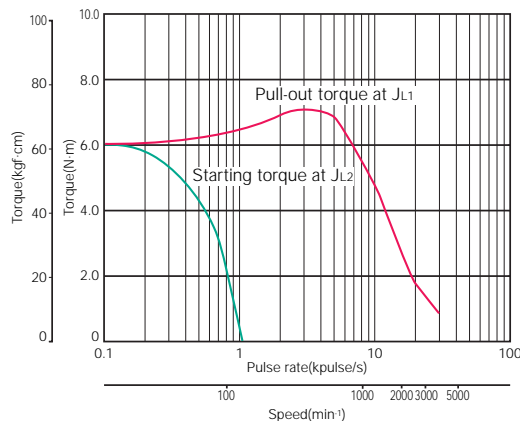

Sanyo constant current circuit
 Source voltage : 100V AC · Winding current : 1.5A/phase
 5-phase excitation (Full step)
 $J_{L1}=43 \times 10^{-4} \text{kg} \cdot \text{m}^2$ (With rubber coupling)
 $J_{L2}=4.4 \times 10^{-4} \text{kg} \cdot \text{m}^2$ (Pulley balancer system)

- 39mm (0.36")
- 60mm (0.45")
- 28mm (0.72")
- 42mm (0.72")
- 50mm (0.72")
- 60mm (0.72")
- 86mm (0.72")
- 106mm (0.72")

CE marked
 Specifications of
 5-phase stepping motor
 In-vacuum
 stepping motor