

\*\*\* 1057 Series \*\*\*

Material:

- \* Insulator: Housing – LCP UL94V-0
- \* Cover: P.P.A. (UL94V-0)
- \* Terminal: Phosphor bronze
- \* Hold-down: Phosphor bronze

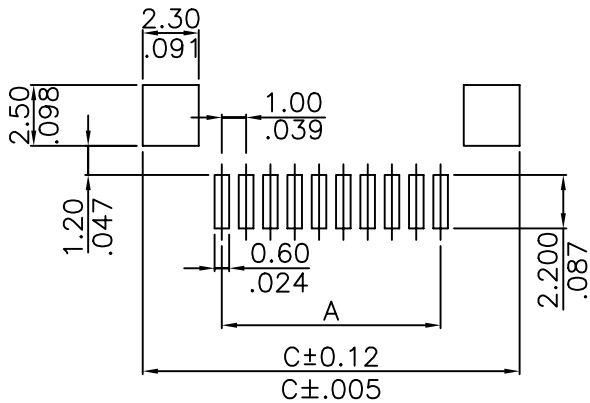
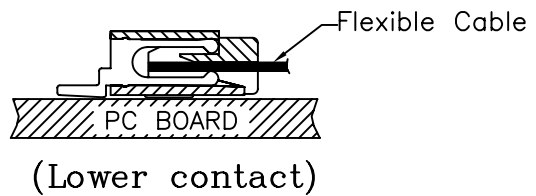
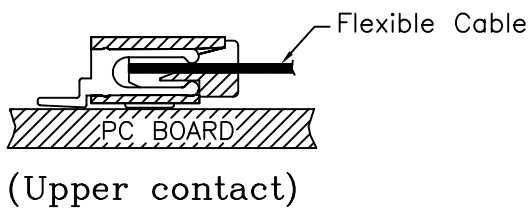
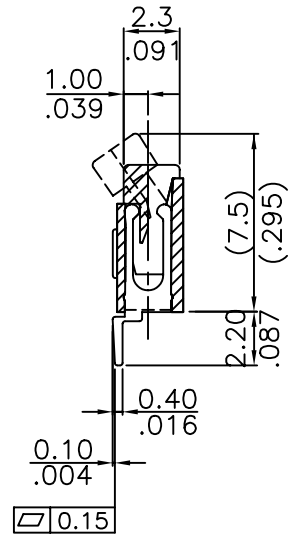
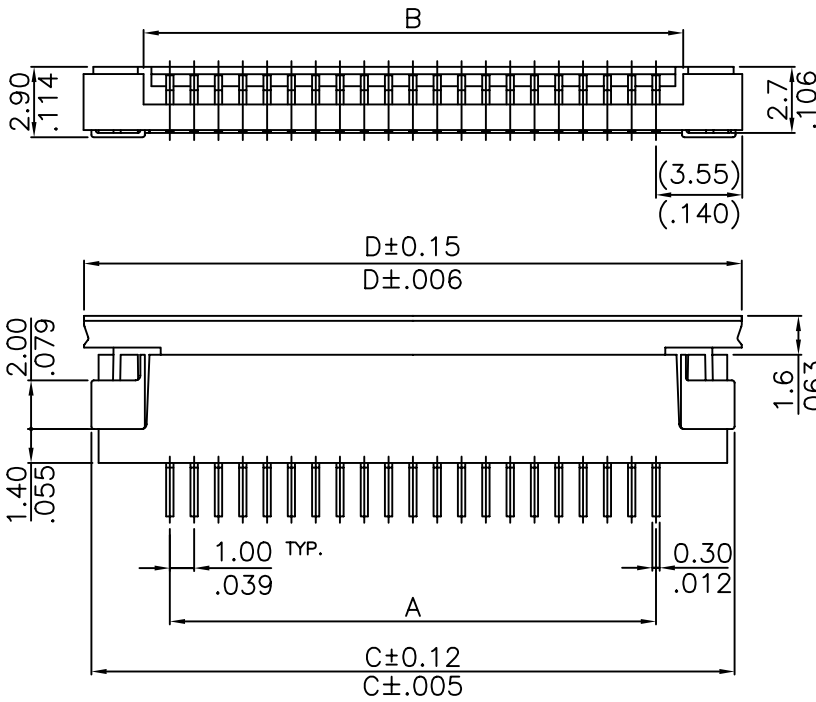

Recommended P.C.Board Pattern

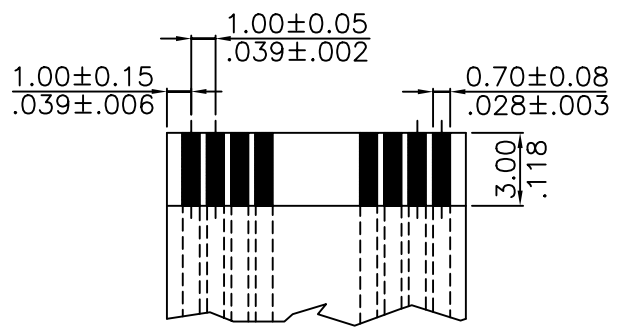

Recommended FFC/FPC Pattern  
Thickness 0.3mm (.012")

				臺灣龍傑股份有限公司 LEOCO CORPORATION		APPROVED BY:		PART NO.:				
				GENERAL TOLERANCE		CHECKED BY:		TITLE:				
				X. ±      X' ± 2'		DRAW BY:		DRAWING NO.:				
B	E000176	JENKUN		.X ± $\frac{0.30}{.012}$ .X' ±				1057S*****0				
A	DWG REL.			.XX ± $\frac{0.20}{.008}$ .XX' ±				1.0mm(.039") Pitch FFC/FPC Connector				
REV.	ECO. NO.	CHG	APPD.	.XXX ± $\frac{0.10}{.004}$ .XXX' ±				UNITS	SCALE	SIZE	SHEET	REV.
								mm / inch	4:1	A4	1/2	B

Ordering Information :

[www.DataSheet.in](http://www.DataSheet.in)

$$1057S \begin{matrix} ** & * & * & * & * & 0 \\ \hline 1 & 2 & 3 & 4 & & \end{matrix}$$

1. No. of circuits
2. U = Upper contact  
D = Lower contact
3. Plating:  
T=Tin plated 120?" min. over 30~50?" nickel overall
4. Packing:  
0 = Tube  
1 = Tape & Reel

Circuits	Dim.A	Dim.B	Dim.C	Dim.D
03	2.00(.079)	4.20(.165)	8.50(.334)	9.10(.358)
04	3.00(.118)	5.20(.205)	9.50(.374)	10.10(.394)
05	4.00(.157)	6.20(.244)	10.50(.413)	11.10(.437)
06	5.00(.197)	7.20(.283)	11.50(.453)	12.10(.476)
07	6.00(.236)	8.20(.323)	12.50(.492)	13.10(.516)
08	7.00(.276)	9.20(.362)	13.50(.531)	14.10(.555)
09	8.00(.315)	10.20(.402)	14.50(.571)	15.10(.594)
10	9.00(.354)	11.20(.441)	15.50(.610)	16.10(.634)
11	10.00(.394)	12.20(.480)	16.50(.650)	17.10(.673)
12	11.00(.433)	13.20(.520)	17.50(.689)	18.10(.713)
13	12.00(.472)	14.20(.559)	18.50(.728)	19.10(.752)
14	13.00(.512)	15.20(.598)	19.50(.768)	20.10(.791)
15	14.00(.551)	16.20(.638)	20.50(.807)	21.10(.831)
16	15.00(.591)	17.20(.677)	21.50(.846)	22.10(.870)
17	16.00(.630)	18.20(.717)	22.50(.886)	23.10(.909)
18	17.00(.669)	19.20(.756)	23.50(.925)	24.10(.949)
19	18.00(.709)	20.20(.795)	24.50(1.037)	25.10(.988)
20	19.00(.748)	21.20(.835)	25.50(1.004)	26.10(1.028)
21	20.00(.787)	22.20(.874)	26.50(1.043)	27.10(1.067)
22	21.00(.827)	23.20(.913)	27.50(1.083)	28.10(1.106)
23	22.00(.866)	24.20(.953)	28.50(1.122)	29.10(1.146)
24	23.00(.906)	25.20(.992)	29.50(1.161)	30.10(1.185)
25	24.00(.945)	26.20(1.031)	30.50(1.201)	31.10(1.224)
26	25.00(.984)	27.20(1.071)	31.50(1.240)	32.10(1.268)
27	26.00(1.024)	28.20(1.110)	32.50(1.280)	33.10(1.303)
28	27.00(1.063)	29.20(1.150)	33.50(1.319)	34.10(1.343)
29	28.00(1.102)	30.20(1.189)	34.50(1.358)	35.10(1.382)
30	29.00(1.142)	31.20(1.228)	35.50(1.398)	36.10(1.421)
31	30.00(1.181)	32.20(1.268)	36.50(1.437)	37.10(1.461)
32	31.00(1.220)	33.20(1.307)	37.50(1.476)	38.10(1.500)

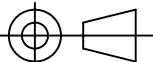
				 臺灣龍傑股份有限公司 LEOCO CORPORATION		APPROVED BY:		PART NO.: 1057S*****0						
				GENERAL TOLERANCE		CHECKED BY:		TITLE: 1.0mm(.039") Pitch FFC/FPC Connector						
				X. ±		X' ± 2'		DRAW BY:		DRAWING NO.: 105702S				
B	E000176	JENKUN		.X ± $\frac{0.30}{.012}$		.X' ±								
A	DWG REL.			.XX ± $\frac{0.20}{.008}$		.XX' ±								
REV.	ECO. NO.	CHG	APPD.	.XXX ± $\frac{0.10}{.004}$		.XXX' ±				UNITS	SCALE	SIZE	SHEET	REV.
										mm inch	4:1	A4	2/2	B