

107-044
EMI/RFI Nickel Plated Copper Knit Braid
 for use with Knit Braid Adapters 380-130, 380-131 and 380-132

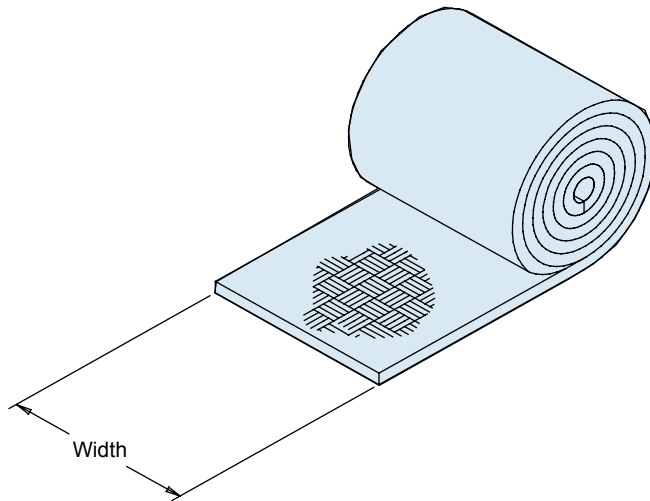
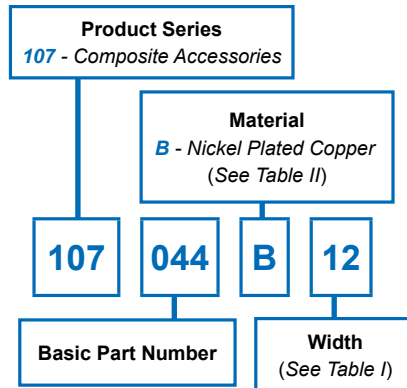

Width Code	Width	Strands Diameter	Approx. No. of Stitches per CM on Length	Approx. No. of Stitches per CM Across Length
12	.472 (12.0)	.006 (0.2)	.138 (3.5)	.173 (4.4)

B *	Nickel Plated Copper
-----	----------------------

* For other material options and sizes please consult factory

- APPLICATION NOTES**
1. The woven braid is to be used with 360° RFI/EMI shield terminations.
 2. Metric dimensions (mm) are in parentheses and are for reference only