



# Dual 24 V, 10 mOhm High Side Switch

The 10XS4200 device is part of a 24 V dual high side switch product family with integrated control, and a high number of protective and diagnostic functions. It has been designed for truck, bus, and industrial applications. The low  $R_{DS(ON)}$  channels (<10 mΩ) can control different load types; bulbs, solenoids, or DC motors. Control, device configuration, and diagnostics are performed through a 16-bit serial peripheral interface (SPI), allowing easy integration into existing applications.

Both channels can be controlled individually by external or internal clock signals, or by direct inputs. Using the internal clock allows fully autonomous device operation. Programmable output voltage slew-rates (individually programmable) helps improve electromagnetic compatibility (EMC) performance. To avoid shutting off the device upon inrush, while still being able to closely track the load current, a dynamic over-current threshold profile is featured. Switching current of each channel can be sensed with a programmable sensing ratio. Whenever communication with the external microcontroller is lost, the device enters a Fail-safe operation mode, but remains operational, controllable, and protected.

## Features

- Two fully protected 10 mΩ (@ 25 °C) high side switches
- Up to 6.0 A steady state current per channel
- Separate bulb and DC motor latched over-current handling
- Individually programmable internal/external PWM clock signals
- Over-current, short-circuit, and over-temperature protection with programmable autoretry functions
- Accurate temperature and current sensing
- Open-load detection (channel in OFF and ON state), also for LED applications (7.0 mA typ.)
- Normal operating range: 8.0 - 36 V, extended range: 6.0 - 58 V
- 3.3 V and 5.0 V compatible 16-bit SPI port for device control, configuration and diagnostics at rates up to 8.0 MHz

**10XS4200**

**HIGH SIDE SWITCH**



**FK SUFFIX (PB-FREE)  
98ASA00428D  
23 PIN PQFN (12 X12 mm)**

## ORDERING INFORMATION

Device	Temperature Range (T <sub>A</sub> )	Package
MC10XS4200FK	-40 to 125 °C	23 PQFN

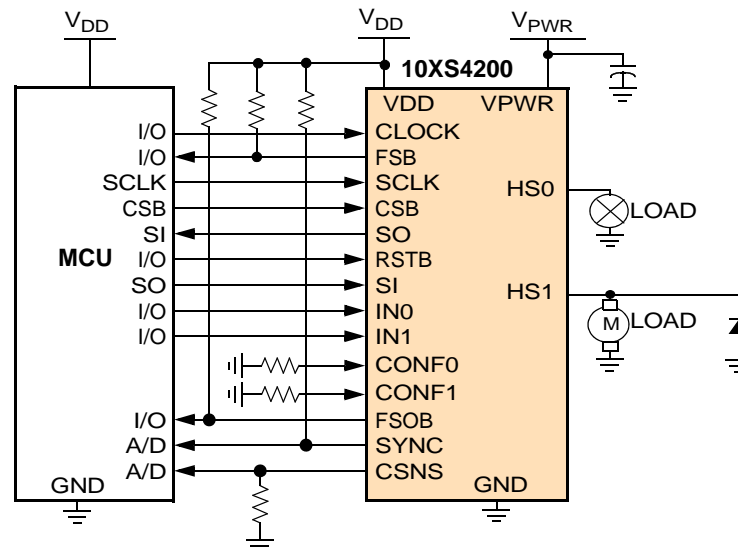

Figure 1. Simplified Application Diagram

\* This document contains certain information on a new product. Specifications and information herein are subject to change without notice.

### INTERNAL BLOCK DIAGRAM

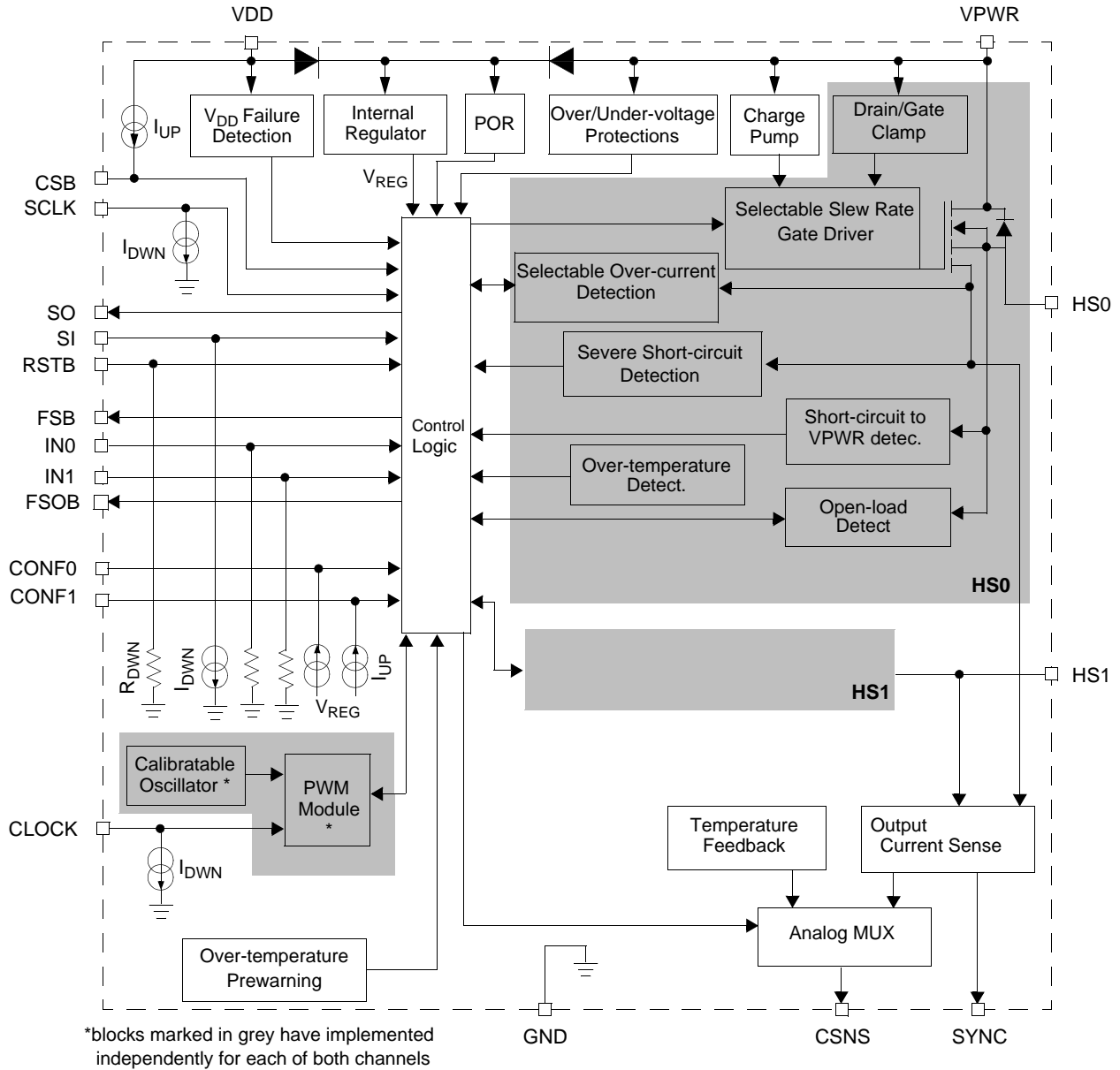

Figure 2. Internal Block Diagram

## TABLE OF CONTENTS

Internal Block Diagram	2
Pin Assignment	4
Electrical Characteristics	6
Maximum Ratings	6
Static Electrical Characteristics	8
Timing Diagrams	20
Functional Description	23
Introduction	23
Pin Assignment and Functions	23
Functional Internal Block Description	25
Functional Device Operation	26
Operation and Operating Modes	26
Protection and Diagnostic Features	32
Logic Commands and SPI Registers	41
Typical Applications	48
Soldering Information	50
Packaging	50
Revision History	59

## PIN ASSIGNMENT

### Transparent Top View

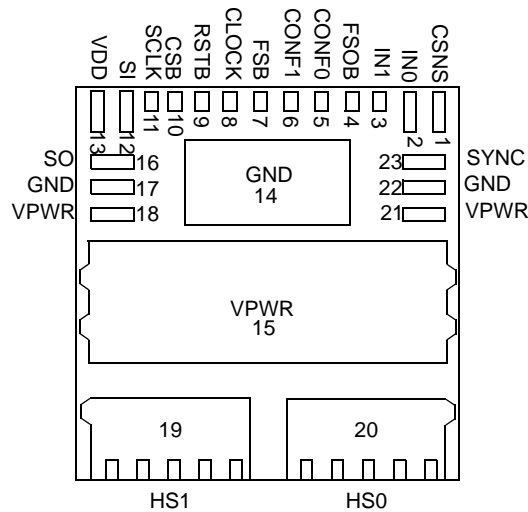

**Figure 3. 10XS4200 Pin Assignments**

**Table 1. 10XS4200 Pin Description**

The function of each pin is described in the section [Functional Description](#)

Pin Number	Pin Name	Function	Formal Name	Definition
1	CSNS	Output	Output Current/ Temperature Monitoring	This pin either outputs a current proportional to the channel's output current or a voltage proportional to the temperature of the GND pin (pin 14). Selection between current and temperature sensing, as well as setting the current sensing sensitivity, are performed through the SPI interface. An external pull-down resistor must be connected between CSNS and GND.
2 3	IN0 IN1	Input	Direct Inputs	The IN[0:1] input pins are used to directly control the switching state of both switches and consequently the voltage on the HS0:HS1 output pins. The pins are connected to GND by internal pull-down resistors
4	FSOB	Output	Fail-safe Output (Active Low)	FSOB is asserted (active-low) upon entering Fail-safe mode (see <a href="#">Functional Description</a> ) This open-drain output requires an external pull-up resistor to VPWR
5 6	CONF0 CONF1	Input	Configuration Input	The CONF[0:1] input pins are used to select the appropriate over-current detection profile (bulb /DC motor) for each of both channels. CONF requires a pull-down resistor to GND.
7	FSB	Output	Fault Status (Active Low)	This open-drain output pin (external pull-up resistor to VDD is required) is set when the device enters Fault mode (see <a href="#">Fault Mode</a> )
8	CLOCK	Input	PWM Clock	The clock input gives the time-base when the device is operated in external clock/internal PWM mode. This pin has an internal pull-down current source.
9	RSTB	Input	Reset	This input pin is used to initialize the device's configuration - and fault registers. Reset will put the device in Sleep mode (low current consumption) provided it is not stimulated by direct input signals. This pin is connected to GND by an internal pull-down resistor.
10	CSB	Input	Chip Select (Active Low)	This input pin is connected to the SPI chip-select output of an external micro-controller. CSB is internally pulled up to V <sub>DD</sub> by a current source I <sub>UP</sub> .

**Table 1. 10XS4200 Pin Description (continued)**

The function of each pin is described in the section [Functional Description](#)

Pin Number	Pin Name	Function	Formal Name	Definition
11	SCLK	Input	Serial Clock	This input pin is to be connected to an external SPI Clock signal. The SCLK pin is internally connected to a pull-down current source $I_{DWN}$
12	SI	Input	Serial Input	This input pin receives the SPI input data from an external device (micro-controller or another extreme switch device in case of daisy-chaining). The SI pin is internally connected to a pull-down current source $I_{DWN}$
13	VDD	Power	Digital Drain Voltage	This is the positive supply pin of the SPI interface.
16	SO	Output	Serial Output	This output pin transmits SPI data to an external device (external micro-controller or the SI pin of the next SPI device in case of daisy-chaining). The pin doesn't require external pull-up or pull-down resistors, but a series resistor is recommended to limit current consumption in case of GND disconnection
14, 17, 22	GND	Ground	Ground	These pins, internally connected, are the ground pins for the logic and analog circuitry. It is recommended to also connect these pins on the PCB.
15,18,21	VPWR	Power	Positive Power Supply	These pins, internally connected, supply both the device's power and control circuitry (except the SPI port). The drain of both internal MOSFET switches is connected to them. Pin 15 is the device's primary thermal pad.
19 20	HS1 HS0	Output	Power Switch Outputs	Output pins of the switches, to be connected to the load.
23	SYNC	Output	Output Current Monitoring Synchronization	This output pin is asserted (logic low) when the Current Sense (CS) output signal is within the specified accuracy range. Reading the SYNC pin allows the external microprocessor to synchronize to the device when operating in autonomous operating mode. SYNC is open-drain and requires a pull-up resistor to VDD.

## ELECTRICAL CHARACTERISTICS

### MAXIMUM RATINGS

**Table 2. Maximum Ratings**

All voltages are relative to ground unless mentioned otherwise. Exceeding these ratings may cause permanent damage.

Parameter	Symbol	Maximum ratings	Unit
<b>ELECTRICAL RATINGS</b>			
VPWR Supply Voltage Range Load Dump at 25 °C (500 ms) Reverse Battery at 25 °C (2 min.) Fast Negative Transient Pulses (ISO 7637-2 pulse #1, $V_{PWR}=14$ V & $R_I=10$ Ω)	$V_{PWR}$	58 -28 -60	V
VDD Supply Voltage Range	$V_{DD}$	-0.3 to 5.5	V
Voltage on Input pins <sup>(6)</sup> (except IN[0:1]) and Output pins <sup>(7)</sup> (except HS[0:1])	$V_{MAX,LOGIC}^{(6)}$	-0.3 to 5.5	V
Voltage on Fail-safe Output (FSOB)	$V_{FSO}$	-0.3 to 58	V
Voltage on SO pin	$V_{SO}$	-0.3 to $V_{DD}+0.3$	V
Voltage (continuous, max. allowable) on IN[0:1] Inputs	$V_{IN,MAX}$	58	V
Voltage (continuous, max. allowable) on output pins (HS [0:1]),	$V_{HS[0:1]}$	-28 to 58	V
Rated Continuous Output Current per channel <sup>(1)</sup>	$I_{HS[0:1]}$	6.0	A
Maximum allowable energy dissipation per channel and two parallel channels, single-pulse method <sup>(2)</sup>	$E_{CL[0:1]_SING}$	300	mJ
Maximum allowable energy dissipation per channel and two parallel channels, repetitive-pulses condition. 1 <sup>(3)</sup>	$E_{CL[0:1]_REP1}$	> 220	mJ
Maximum allowable energy dissipation per channel and two parallel channels, repetitive-pulses condition. 2 <sup>(4)</sup>	$E_{CL[0:1]_REP2}$	> 220	mJ
ESD Voltage <sup>(5)</sup> Human Body Model (HBM) for HS[0:1], VPWR and GND Human Body Model (HBM) for other pins Charge Device Model (CDM) Package Corner pins (1, 13, 19, 20) All Other pins	$V_{ESD1}$ $V_{ESD2}$ $V_{ESD3}$ $V_{ESD4}$	±8000 ±2000 ±750 ±500	V

**Notes:**

- Output current rating valid as long as maximum junction temperature is not exceeded. For computation of the maximum allowable output current, the thermal resistance of the package & the underlying heatsink must be taken into account
- Single pulse Energy dissipation, Single-pulse short-circuit method ( $L_L = 2.0$  mH,  $R = 30$  mΩ  $V_{PWR} = 28$  V,  $T_J = 150$  °C initial).
- Dissipation during repetitive cycles: switch off upon short-circuit ( $L_L = 20$  μH,  $R = 200$  mΩ,  $V_{PWR} = 28$  V,  $T_J = 125$  °C initial,  $f_S < 2.0$  Hz).
- Dissipation during repetitive cycles: switch off upon short-circuit ( $L_L = 40$  μH,  $R = 400$  mΩ,  $V_{PWR} = 28$  V,  $T_J = 125$  °C initial,  $f_S < 2.0$  Hz).
- ESD testing is performed in accordance with the Human Body Model (HBM) ( $C_{ZAP} = 100$  pF,  $R_{ZAP} = 1500$  Ω), and the Charge Device Model (CDM), Robotic ( $C_{ZAP} = 4.0$  pF).
- Concerned Input pins are: CONF[0:1], RSTB, SI, SCLK, Clock, and CSB.
- Concerned Output pins are: CSNS, SYNC, and FSB.

**Table 2. Maximum Ratings (continued)**

All voltages are relative to ground unless mentioned otherwise. Exceeding these ratings may cause permanent damage.

Parameter	Symbol	Maximum ratings	Unit
<b>THERMAL RATINGS</b>			
Operating Temperature			°C
Ambient	$T_A$	-40 to 125	
Junction	$T_J$	-40 to 150	
Storage Temperature	$T_{STG}$	-55 to 150	°C
Thermal Resistance Junction to Case Bottom/ VPWR Flag Surface	$R_{\theta JC}$	0.22	°C/W
Peak package reflow temperature during reflow <sup>(8),(9)</sup>	$T_{PPRT}$	Note 9	°C

**Notes:**

- Pin soldering temperature limit is for 40 seconds maximum duration. Not designed for immersion soldering. Exceeding these limits may cause malfunction or permanent damage to the device.
- Freescle's Package Reflow capability meets Pb-free requirements for JEDEC standard J-STD-020. For Peak Package Reflow Temperature and Moisture Sensitivity Levels (MSL), Go to [www.freescale.com](http://www.freescale.com), search by part number [e.g. remove prefixes/suffixes and enter the core ID to view all orderable parts. (i.e. MC33xxxD enter 33xxx), and review parametrics.

### STATIC ELECTRICAL CHARACTERISTICS

**Table 3. Static Electrical Characteristics**

Unless specified otherwise:  $8.0\text{ V} \leq V_{PWR} \leq 36\text{ V}$ ,  $3.0\text{ V} \leq V_{DD} \leq 5.5\text{ V}$ ,  $-40\text{ }^\circ\text{C} \leq T_A \leq 125\text{ }^\circ\text{C}$ ,  $\text{GND} = 0\text{ V}$ . Typical values are average values evaluated under nominal conditions  $T_A = 25\text{ }^\circ\text{C}$ ,  $V_{PWR} = 28\text{ V}$  &  $V_{DD} = 5.0\text{ V}$ , unless specified otherwise.

parameter	Symbol	Min	Typ	Max	Unit
<b>SUPPLY ELECTRICAL CHARACTERISTICS</b>					
Supply Voltage Range: Full Specification compliant Extended Mode <sup>(10)</sup>	$V_{PWR}$	8.0 6.0	24 –	36 58	V
$V_{PWR}$ Supply Current, device in wake-up mode, channel On, Open-load outputs in ON-state, HS[0:1] open, IN[0:1] > $V_{IH}$	$I_{PWR(ON)}$	–	6.5	8.0	mA
$V_{PWR}$ Supply Current, device in wake-up mode (Standby), channel Off Open-load in OFF-state Detection Disabled, HS[0:1] shorted to ground with $V_{DD} = 5.5\text{ V}$ and $\text{RSTB} > V_{WAKE}$	$I_{PWR(SBY)}$	–	6.5	8.0	mA
Sleep State Supply Current $V_{PWR} = 24\text{ V}$ , $\text{RSTB} = \text{IN}[0:1] < V_{WAKE}$ , HS[0:1] connected to ground $T_A = 25\text{ }^\circ\text{C}$ $T_A = 125\text{ }^\circ\text{C}$	$I_{PWR(SLEEP)}$	– –	3.0 –	10.0 60.0	$\mu\text{A}$
$V_{DD}$ Supply Voltage	$V_{DD(ON)}$	3.0	–	5.5	V
$V_{DD}$ Supply Current at $V_{DD} = 5.5\text{ V}$ No SPI Communication 8.0 MHz SPI Communication <sup>(11)</sup>	$I_{DD(ON)}$	– –	– 5.0	2.2 –	mA
$V_{DD}$ Sleep State Current at $V_{DD} = 5.5\text{ V}$ with or without $V_{PWR}$	$I_{DD(SLEEP)}$	–	–	5.0	$\mu\text{A}$
Over-voltage Shutdown Threshold	$V_{PWR(OV)}$	39	42	45.5	V
Over-voltage Shutdown Hysteresis	$V_{PWR(OVHYS)}$	0.2	0.8	1.5	V
Under-voltage Shutdown Threshold <sup>(12)</sup>	$V_{PWR(UV)}$	5.0	–	6.0	V
$V_{PWR}$ Power-On-Reset (POR) Voltage Threshold <sup>(12)</sup>	$V_{PWR(POR)}$	2.2	2.6	4.0	V
$V_{DD}$ Power-On-Reset (POR) Voltage Threshold <sup>(12)</sup>	$V_{DD(POR)}$	1.5	2.0	2.5	V
$V_{DD}$ Supply Failure Voltage Threshold (assumed $V_{PWR} > V_{PWR(UV)}$ )	$V_{DD(FAIL)}$	2.2	2.5	2.8	V

**Notes**

- In extended mode, several device functions (channel control,  $R_{DS(ON)}$  and over-temperature protection) are guaranteed, but compliance with the specified values in this document is not. Below 6.0 V, the device is only protected from overheating (thermal shutdown). Above  $V_{PWR(OV)}$ , the channels can only be turned ON when the over-voltage detection function has been disabled.
- Typical value guaranteed per design.
- When the device recovers from under-voltage and returns to normal mode ( $6.0\text{ V} < V_{PWR} < 58\text{ V}$ ) before the end of the auto-retry period (see [Auto-retry](#)), the device will perform normally. When  $V_{PWR}$  drops below  $V_{PWR(UV)}$ , under-voltage is detected see [Under-voltage Fault \(Latchable Fault\)](#) and [EMC Performances](#).



**Table 3. Static Electrical Characteristics (continued)**

Unless specified otherwise:  $8.0\text{ V} \leq V_{PWR} \leq 36\text{ V}$ ,  $3.0\text{ V} \leq V_{DD} \leq 5.5\text{ V}$ ,  $-40\text{ }^\circ\text{C} \leq T_A \leq 125\text{ }^\circ\text{C}$ ,  $\text{GND} = 0\text{ V}$ . Typical values are average values evaluated under nominal conditions  $T_A = 25\text{ }^\circ\text{C}$ ,  $V_{PWR} = 28\text{ V}$  &  $V_{DD} = 5.0\text{ V}$ , unless specified otherwise.

parameter	Symbol	Min	Typ	Max	Unit
<b>ELECTRICAL CHARACTERISTICS OF THE OUTPUT STAGE (HS0 AND HS1)</b>					
ON-Resistance, Drain-to-Source ( $I_{HS} = 3.0\text{ A}$ , $T_J = 25\text{ }^\circ\text{C}$ ) CSNS_ratio = 0 $V_{PWR} = 8.0\text{ V}$ $V_{PWR} = 28\text{ V}$ $V_{PWR} = 36\text{ V}$	$R_{DS(ON)25\_0}$	–	–	10	m $\Omega$
ON-Resistance, Drain-to-Source ( $I_{HS} = 1.0\text{ A}$ , $T_J = 25\text{ }^\circ\text{C}$ ) CSNS_ratio = 1 $V_{PWR} = 8.0\text{ V}$ $V_{PWR} = 28\text{ V}$ $V_{PWR} = 36\text{ V}$	$R_{DS(ON)25\_1}$	–	–	10	m $\Omega$
ON-Resistance, Drain-to-Source ( $I_{HS} = 3.0\text{ A}$ , $T_J = 150\text{ }^\circ\text{C}$ ) CSNS_ratio = 0 $V_{PWR} = 8.0\text{ V}$ $V_{PWR} = 28\text{ V}$ $V_{PWR} = 36\text{ V}$	$R_{DS(ON)150\_0}$	–	–	18	m $\Omega$
ON-Resistance, Drain-to-Source ( $I_{HS} = 1.0\text{ A}$ , $T_J = 150\text{ }^\circ\text{C}$ ) CSNS_ratio = 1 $V_{PWR} = 8.0\text{ V}$ $V_{PWR} = 28\text{ V}$ $V_{PWR} = 36\text{ V}$	$R_{DS(ON)150\_1}$	–	–	18	m $\Omega$
ON-Resistance, Drain-to-Source difference from one channel to the other in parallel mode ( $I_{HS} = 1.0\text{ A}$ , $T_J = 150\text{ }^\circ\text{C}$ ) CSNS_ratio = X	$\Delta R_{DS(ON)150}$	-0.8	–	+0.8	m $\Omega$
ON-Resistance, Source-Drain ( $I_{HS} = -3.0\text{ A}$ , $T_J = 150\text{ }^\circ\text{C}$ , $V_{PWR} = -24\text{ V}$ )	$R_{SD(ON)150}$	–	–	18	m $\Omega$
Max. detectable wiring length (2.5 mm <sup>2</sup> ) for severe short-circuit detection (see <a href="#">Power Supply</a> ): High slew rate selected Medium slew rate selected: Low slew rate selected:	$L_{SHORT}$	20 50 100	85 160 280	140 300 600	cm
Over-current Detection thresholds with CSNS_ratio bit = 0 (CSR0)	OCH1_0 OCH2_0 OCM1_0 OCM2_0 OCL1_0 OCL2_0 OCL3_0	55 35 22 13 9.0 6.0 3.0	66 42 26 16 10.8 7.2 3.6	77 49 31 19.5 12.6 8.4 4.2	A

**Table 3. Static Electrical Characteristics (continued)**

Unless specified otherwise:  $8.0\text{ V} \leq V_{PWR} \leq 36\text{ V}$ ,  $3.0\text{ V} \leq V_{DD} \leq 5.5\text{ V}$ ,  $-40\text{ }^\circ\text{C} \leq T_A \leq 125\text{ }^\circ\text{C}$ ,  $\text{GND} = 0\text{ V}$ . Typical values are average values evaluated under nominal conditions  $T_A = 25\text{ }^\circ\text{C}$ ,  $V_{PWR} = 28\text{ V}$  &  $V_{DD} = 5.0\text{ V}$ , unless specified otherwise.

parameter	Symbol	Min	Typ	Max	Unit
<b>ELECTRICAL CHARACTERISTICS OF THE OUTPUT STAGE (HS0 AND HS1) (CONTINUED)</b>					
Over-current Detection thresholds with CSNS_ratio bit = 1(CSR1)	OCH1_1	18.3	22	26.5	A
	OCH2_1	11.7	14.0	16.3	
	OCM1_1	7.2	8.7	10.1	
	OCM2_1	4.4	5.3	6.2	
	OCL1_1	3.0	3.6	4.2	
	OCL2_1	2.0	2.4	2.8	
	OCL3_1	0.96	1.2	1.44	
Output pin leakage Current in sleep state (positive value = outgoing) $V_{HS,OFF} = 0\text{ V}$ ( $V_{HS,OFF}$ = output voltage in OFF state) $V_{HS,OFF} = V_{PWR}$ , device in sleep state ( $V_{PWR} = 24\text{ V max.}$ )	$I_{OUT\_LEAK}$	-	-	+11	$\mu\text{A}$
		-40.0	-	+5.0	
Switch Turn-on threshold for Supply over-voltage ( $V_{PWR}$ -GND) (see <sup>(13)</sup> )	$V_{D\_GND(CLAMP)}$	58	-	66	V
Switch turn-on threshold for Drain-Source over-voltage (measured at $I_{OUT} = 500\text{ mA}$ , see <a href="#">Figure 19</a> )	$V_{DS(CLAMP)}$	58	-	66	V
Current Sensing Ratio <sup>(14)</sup> CSNS_ratio bit = 0 (high current mode) CSNS_ratio bit = 1 (low current mode)	$C_{SR0}$ $C_{SR1}$	-	1/3000 1/1000	-	-
Minimum measurable load current with compensated error <sup>(15)</sup>	$I_{LOAD\_MIN}$	-	-	100	mA
CSNS leakage current in OFF state ( $CSNSx\_en = 0$ , $CSNS\_ratio\ bit\_x = 0$ )	$I_{CSR\_LEAK}$	-4.0	-	+4.0	$\mu\text{A}$
Systematic offset error (see <a href="#">Current Sense Errors</a> )	$I_{LOAD\_ERR\_SYS}$	-	11	-	mA
Random offset error	$I_{LOAD\_ERR\_RAND}$	-150	-	150	mA

**Notes:**

- Current Sense Ratio  $C_{SRx} = I_{CSNS} / I_{HS[x]}$
- $E_{SRx\_ERR} = (I_{CSNS\_MEAS} / I_{CSNS\_MODEL}) - 1$ , with  $I_{CSNS\_MODEL} = (I_{HS[x]} + I_{LOAD\_ERR\_SYS}) * C_{SRx}$ , ( $I_{LOAD\_ERR\_SYS}$  defined above, see section [Current Sense Error Model](#)). With this model, load current becomes:  $I_{HS[x]} = I_{CSNS} / C_{SRx} - I_{LOAD\_ERR\_SYS}$
- See note <sup>(14)</sup>, but with  $I_{CSNS\_MEAS}$  obtained after compensation of  $I_{LOAD\_ERR\_RAND}$  (see [Activation and Use of Offset Compensation](#)). Further accuracy improvements can be obtained by performing a 1- or 2 point calibration.

**Table 3. Static Electrical Characteristics (continued)**

Unless specified otherwise:  $8.0\text{ V} \leq V_{PWR} \leq 36\text{ V}$ ,  $3.0\text{ V} \leq V_{DD} \leq 5.5\text{ V}$ ,  $-40\text{ }^\circ\text{C} \leq T_A \leq 125\text{ }^\circ\text{C}$ ,  $\text{GND} = 0\text{ V}$ . Typical values are average values evaluated under nominal conditions  $T_A = 25\text{ }^\circ\text{C}$ ,  $V_{PWR} = 28\text{ V}$  &  $V_{DD} = 5.0\text{ V}$ , unless specified otherwise.

parameter	Symbol	Min	Typ	Max	Unit
<b>ELECTRICAL CHARACTERISTICS OF THE OUTPUT STAGE (HS0 AND HS1) (CONTINUED)</b>					
$E_{SR0}$ Output Current Sensing Error (% un-compensated <sup>(16)</sup> ) at output current level (Sense ratio $C_{SR0}$ selected):	$E_{SR0\_ERR}$				%
$T_J = -40\text{ }^\circ\text{C}$					
6.0 A		-13	–	13	
3.0 A		-12	–	12	
1.5 A		-17	–	17	
0.75 A		-31	–	31	
$T_J = 125\text{ }^\circ\text{C}$					
6.0 A		-10	–	10	
3.0 A		-9.0	–	9.0	
1.5 A		-12	–	12	
0.75 A		-19	–	19	
$T_J = 25\text{ to }125\text{ }^\circ\text{C}$					
6.0 A		-10	–	10	
3.0 A		-9.0	–	9.0	
1.5 A		-12	–	12	
0.75 A		-22	–	22	
$E_{SR0}$ Output Current Sensing Error (% after offset compensation <sup>(17)</sup> ) at output current level (Sense ratio $C_{SR0}$ selected):	$E_{SR0\_ERR(Comp)}$				%
$T_J = -40\text{ }^\circ\text{C}$					
6.0 A		-10	–	10	
3.0 A		-10	–	10	
1.5 A		-10	–	10	
0.75 A		-10	–	10	
$T_J = 125\text{ }^\circ\text{C}$					
6.0 A		-9.0	–	9.0	
3.0 A		-8.0	–	8.0	
1.5 A		-8.0	–	8.0	
0.75 A		-9.0	–	9.0	
$T_J = 25\text{ to }125\text{ }^\circ\text{C}$					
6.0 A		-9.0	–	9.0	
3.0 A		-8.0	–	8.0	
1.5 A		-8.0	–	8.0	
0.75 A		-9.0	–	9.0	

**Notes:**

- $E_{SRx\_ERR} = (I_{CSNS\_MEAS} / I_{CSNS\_MODEL}) - 1$ , with  $I_{CSNS\_MODEL} = (I(HS[x]) + I_{LOAD\_ERR\_SYS}) * C_{SRx}$ , ( $I_{LOAD\_ERR\_SYS}$  defined above, see section [Current Sense Error Model](#)). With this model, load current becomes:  $I(HS[x]) = I_{CSNS} / C_{SRx} - I_{LOAD\_ERR\_SYS}$
- See note <sup>(16)</sup>, but with  $I_{CSNS\_MEAS}$  obtained after compensation of  $I_{LOAD\_ERR\_RAND}$  (see [Activation and Use of Offset Compensation](#)). Further accuracy improvements can be obtained by performing a 1- or 2 point calibration.

**Table 3. Static Electrical Characteristics (continued)**

Unless specified otherwise:  $8.0\text{ V} \leq V_{PWR} \leq 36\text{ V}$ ,  $3.0\text{ V} \leq V_{DD} \leq 5.5\text{ V}$ ,  $-40\text{ }^\circ\text{C} \leq T_A \leq 125\text{ }^\circ\text{C}$ ,  $\text{GND} = 0\text{ V}$ . Typical values are average values evaluated under nominal conditions  $T_A = 25\text{ }^\circ\text{C}$ ,  $V_{PWR} = 28\text{ V}$  &  $V_{DD} = 5.0\text{ V}$ , unless specified otherwise.

parameter	Symbol	Min	Typ	Max	Unit
<b>ELECTRICAL CHARACTERISTICS OF THE OUTPUT STAGE (HS0 AND HS1) (CONTINUED)</b>					
$E_{SR1}$ Output Current Sensing Error (% , uncompensated <sup>(18)</sup> ) at output current level (Sense ratio $C_{SR1}$ selected): $T_J = -40\text{ }^\circ\text{C}$ 1.5 A $T_J = 125\text{ }^\circ\text{C}$ 1.5 A $T_J = 25\text{ to }125\text{ }^\circ\text{C}$ 1.5 A	$E_{SR1\_ERR}$	-15  -12  -12	-  -  -	15  12  12	%
$E_{SR1}$ Output Current Sensing Error (% (level) after offset compensation <sup>(19)</sup> ) at output current level (Sense ratio $C_{SR1}$ selected): $T_J = -40\text{ }^\circ\text{C}$ 1.5 A 0.5 A 0.25 A 0.15 A $T_J = 125\text{ }^\circ\text{C}$ 1.5 A 0.5 A 0.25 A 0.15 A $T_J = 25\text{ to }125\text{ }^\circ\text{C}$ 1.5 A 0.5 A 0.25 A 0.15 A	$E_{SR1\_ERR(Comp)}$	-10 -11 -18 -29  -8.0 -10 -12 -16  -8.0 -10 -13 -21	- - - -  - - - -  - - - -	10 11 18 29  8.0 10 12 16  8.0 10 13 21	%
$E_{SR0}$ Output Current Sensing Error in parallel mode (% , uncompensated <sup>(18)</sup> ) at outputs Current level (Sense ratio $C_{SR0}$ selected): $T_J = -40\text{ }^\circ\text{C}$ 6.0 A 3.0 A $T_J = 125\text{ }^\circ\text{C}$ 6.0 A 3.0 A $T_J = 25\text{ to }125\text{ }^\circ\text{C}$ 6.0 A 3.0 A	$E_{SR0\_ERR\_PAR}$	-10 -11  -8.0 -8.0  -8.0 -8.0	- -  - -  - -	10 11  8.0 8.0  8.0 8.0	%

**Notes:**

- $E_{SRx\_ERR} = (I_{CSNS\_MEAS} / I_{CSNS\_MODEL}) - 1$ , with  $I_{CSNS\_MODEL} = (I(HS[x]) + I_{LOAD\_ERR\_SYS}) * C_{SRx}$ , ( $I_{LOAD\_ERR\_SYS}$  defined above, see section [Current Sense Error Model](#)). With this model, load current becomes:  $I(HS[x]) = I_{CSNS} / C_{SRx} - I_{LOAD\_ERR\_SYS}$
- See note <sup>(18)</sup>, but with  $I_{CSNS\_MEAS}$  obtained after compensation of  $I_{LOAD\_ERR\_RAND}$  (see [Activation and Use of Offset Compensation](#)). Further accuracy improvements can be obtained by performing a 1- or 2 point calibration.

**Table 3. Static Electrical Characteristics (continued)**

Unless specified otherwise:  $8.0\text{ V} \leq V_{PWR} \leq 36\text{ V}$ ,  $3.0\text{ V} \leq V_{DD} \leq 5.5\text{ V}$ ,  $-40\text{ }^\circ\text{C} \leq T_A \leq 125\text{ }^\circ\text{C}$ ,  $\text{GND} = 0\text{ V}$ . Typical values are average values evaluated under nominal conditions  $T_A = 25\text{ }^\circ\text{C}$ ,  $V_{PWR} = 28\text{ V}$  &  $V_{DD} = 5.0\text{ V}$ , unless specified otherwise.

parameter	Symbol	Min	Typ	Max	Unit
<b>ELECTRICAL CHARACTERISTICS OF THE OUTPUT STAGE (HS0 AND HS1) (CONTINUED)</b>					
Current Sense Clamping Voltage (condition: $R(\text{CSNS}) > 10\text{ k}\Omega$ )	$V_{CL}(\text{CSNS})$	5.5	–	7.5	V
Open-load detection Current threshold in OFF state <sup>(20)</sup>	$I_{OLD}(\text{OFF})$	30	–	100	$\mu\text{A}$
Open-load Fault Detection Voltage Threshold <sup>(20)</sup>	$V_{OLD}(\text{THRES})$	4.0	–	5.5	V
Open-load detection Current threshold in ON state (see <a href="#">Open-Load Detection In On State (OL_ON)</a> ): CSNS_ratio bit = 0 CSNS_ratio bit = 1 (fast slew rate $\text{SR}[1:0] = 10$ mandatory for this function)	$I_{OLD}(\text{ON})$	120 5.0	300 7.0	600 10	mA
Time period of the periodically activated Open-load in ON state detection for CSNS_ratio bit = 1	$t_{OLLED}$	105	150	195	ms
Output Shorted-to- $V_{PWR}$ Detection Voltage Threshold (channel in OFF state)	$V_{OSD}(\text{THRES})$	$V_{PWR}-1.2$	$V_{PWR}-0.8$	$V_{PWR}-0.4$	V
Switch turn-on threshold for Negative Output Voltages (protects against negative transients) - (measured at $I_{OUT} = 100\text{ mA}$ , Channel in OFF state)	$V_{CL}$	-35	–	-24	V
Switch turn-on threshold for Negative Output Voltages difference from one channel to the other in parallel mode - (measured at $I_{OUT} = 100\text{ mA}$ , Channel in OFF state)	$\Delta V_{CL}$	-2.0	–	+2.0	V
Switching State (On/Off) discrimination thresholds	$V_{HS\_TH}$	$0.45 \cdot V_{PWR}$	$0.5 \cdot V_{PWR}$	$0.55 \cdot V_{PWR}$	V
Shutdown temperature (Power MOSFET junction; $6.0\text{ V} < V_{PWR} < 58\text{ V}$ )	$T_{SD}$	160	175	190	$^\circ\text{C}$

**ELECTRICAL CHARACTERISTICS OF THE CONTROL INTERFACE PINS**

Logic Input Voltage, High <sup>(21)</sup>	$V_{IH}$	2.0	–	5.5	V
Logic Input Voltage, Low <sup>(21)</sup>	$V_{IL}$	-0.3	–	0.8	V
Wake-up Threshold Voltage (IN[0:1] and RSTB) <sup>(22)</sup>	$V_{WAKE}$	1.0	–	2.2	V
Internal Pull-down Current Source (on inputs: CLOCK, SCLK and SI) <sup>(23)</sup>	$I_{DWN}$	5.0	–	20	$\mu\text{A}$
Internal Pull-up Current Source (input CSB) <sup>(24)</sup>	$I_{UP\_CSB}$	5.0	–	20	$\mu\text{A}$
Internal Pull-up Current Source (input CONF[0:1]) <sup>(25)</sup>	$I_{UP\_CONF}$	25	–	100	$\mu\text{A}$
Capacitance of SO, FSB and FSOB pins in Tri-state	$C_{SO}$	–	–	20	pF
Internal Pull-down Resistance (RSTB and IN[0:1])	$R_{DWN}$	125	250	500	k $\Omega$
Input Capacitance <sup>(26)</sup>	$C_{IN}$	–	4.0	12	pF

**Notes:**

- Minimum required value of Open-load impedance for detection of Open-load in OFF-state:  $200\text{ k}\Omega$ . ( $V_{OLD}(\text{THRES}) = V_{HS} @ I_{OLD}(\text{OFF})$ )
- High and low voltage ranges apply to SI, CSB, SCLK, RSTB, IN[0:1] and CLOCK input signals. The IN[0:1] signals may be derived from  $V_{PWR}$  and can tolerate voltages up to 58 V.
- Voltage above which the device will wake-up
- Pull-down current-value for  $V_{SI} \geq 0.8\text{ V}$  and  $V_{SCLK} \geq 0.8\text{ V}$  and  $V_{CLOCK} \geq 0.8\text{ V}$ .
- Pull-up current-value for  $V_{CSB} \leq 2.0\text{ V}$ . CSB has an internal pull-up current source connected to  $V_{DD}$ .
- Pins CONF[0:1] are connected to an internal current source, connected itself to an internal voltage regulator ( $V_{REG} \sim 3.0\text{ V}$ ).
- Input capacitance of SI, CSB, SCLK, RSTB, IN[0:1], CONF[0:1], and CLOCK pins. This parameter is guaranteed by the manufacturing process but is not tested in production.

**Table 3. Static Electrical Characteristics (continued)**

Unless specified otherwise:  $8.0\text{ V} \leq V_{PWR} \leq 36\text{ V}$ ,  $3.0\text{ V} \leq V_{DD} \leq 5.5\text{ V}$ ,  $-40\text{ }^\circ\text{C} \leq T_A \leq 125\text{ }^\circ\text{C}$ ,  $\text{GND} = 0\text{ V}$ . Typical values are average values evaluated under nominal conditions  $T_A = 25\text{ }^\circ\text{C}$ ,  $V_{PWR} = 28\text{ V}$  &  $V_{DD} = 5.0\text{ V}$ , unless specified otherwise.

parameter	Symbol	Min	Typ	Max	Unit
<b>ELECTRICAL CHARACTERISTICS OF THE CONTROL INTERFACE PINS (CONTINUED)</b>					
SO High-state Output Voltage ( $I_{OH} = 1.0\text{ mA}$ )	$V_{SOH}$	$V_{DD}-0.4$	–	–	V
SYNC, SO, FSOB and FSB Low-state Output Voltage ( $I_{OL} = -1.0\text{ mA}$ )	$V_{SOL}$	–	–	0.4	V
SYNC, SO, CSNS, FSOB and FSB Tri-state Leakage Current: ( $0.0\text{ V} < V(\text{SO}) < V_{DD}$ , or $V(\text{FS})$ or $V(\text{SYNC}) = 5.5\text{ V}$ , or $V(\text{FSO}) = 36\text{ V}$ or $V(\text{CSNS}) = 0\text{ V}$ )	$I_{SO(\text{LEAK})}$	-2.0	0.0	2.0	$\mu\text{A}$
CONF[0:1] Required values of the External Pull-down Resistor - Lighting applications - DC motor applications	$R_{CONF}$	1.0 50	– –	10 Infinite	$\text{k}\Omega$

**DYNAMIC ELECTRICAL CHARACTERISTICS**

**Table 4. Dynamic Electrical Characteristics**

Unless specified otherwise:  $8.0\text{ V} \leq V_{PWR} \leq 36\text{ V}$ ,  $3.0\text{ V} \leq V_{DD} \leq 5.5\text{ V}$ ,  $-40\text{ }^\circ\text{C} \leq T_A \leq 125\text{ }^\circ\text{C}$ ,  $GND = 0\text{ V}$ . Typical values are average values evaluated under nominal conditions  $T_A = 25\text{ }^\circ\text{C}$ ,  $V_{PWR} = 28\text{ V}$  &  $V_{DD} = 5.0\text{ V}$ , unless specified otherwise.

Parameter	Symbol	Min	Typ	Max	Unit
<b>OUTPUT VOLTAGE SWITCHING CHARACTERISTICS</b>					
Rising and Falling edges medium slew rate (SR[1:0] = 00) <sup>(27)</sup> $V_{PWR} = 16\text{ V}$ $V_{PWR} = 28\text{ V}$ $V_{PWR} = 36\text{ V}$	SR <sub>R_00</sub> SR <sub>F_00</sub>	0.164 0.28 0.34	– – –	0.65 0.79 0.90	V/ $\mu$ s
Rising and Falling edges low slew rate (SR[1:0] = 01) <sup>(27)</sup> $V_{PWR} = 16\text{ V}$ $V_{PWR} = 28\text{ V}$ $V_{PWR} = 36\text{ V}$	SR <sub>R_01</sub> SR <sub>F_01</sub>	0.081 0.14 0.17	– – –	0.32 0.395 0.45	V/ $\mu$ s
Rising and Falling edges high slew rate / SR[1:0] = 10) <sup>(27)</sup> $V_{PWR} = 16\text{ V}$ $V_{PWR} = 28\text{ V}$ $V_{PWR} = 36\text{ V}$	SR <sub>R_10</sub> SR <sub>F_10</sub>	0.29 0.55 0.68	– – –	1.30 1.58 1.80	V/ $\mu$ s
Rising/Falling edge slew rate matching (SR <sub>R</sub> /SR <sub>F</sub> ) $16\text{ V} < V_{PWR} < 36\text{ V}$	$\Delta$ SR	0.75	1.0	1.2	
Edge slew rate difference from one channel to the other in parallel mode <sup>(27)</sup> $16\text{ V} < V_{PWR} < 36\text{ V}$ SR[1:0] = 00 SR[1:0] = 01 SR[1:0] = 10	$\Delta$ SR	-0.1 -0.06 -0.14	0.0 0.0 0.0	+0.1 +0.06 +0.14	V/ $\mu$ s
Output Turn-ON and Turn-OFF Delays (medium slew rate: SR[1:0] = 00) <sup>(28)</sup> $16\text{ V} < V_{PWR} < 36\text{ V}$	t <sub>DLY_00</sub>	32	–	128	$\mu$ s
Output Turn-ON and Turn-OFF Delays (low slew rate / SR[1:0] = 01) <sup>(28)</sup> $16\text{ V} < V_{PWR} < 36\text{ V}$	t <sub>DLY_01</sub>	59	–	245	$\mu$ s
Output Turn-ON and Turn-OFF Delays (high slew rate / SR[1:0] = 10) <sup>(28)</sup> $16\text{ V} < V_{PWR} < 36\text{ V}$	t <sub>DLY_10</sub>	18	–	68	$\mu$ s
Turn-ON and Turn-OFF Delay time matching (t <sub>DLY(ON)</sub> - t <sub>DLY(OFF)</sub> ) f <sub>PWM</sub> = 400 Hz, $16\text{ V} < V_{PWR} < 36\text{ V}$ , duty cycle on IN[x] = 50 %, SR[1:0] = 00	$\Delta$ t <sub>RF_00</sub>	-25	0.0	25	$\mu$ s
Turn-ON and Turn-OFF Delay time matching (t <sub>DLY(ON)</sub> - t <sub>DLY(OFF)</sub> ) f <sub>PWM</sub> = 200 Hz, $16\text{ V} < V_{PWR} < 36\text{ V}$ , duty cycle on IN[x] = 50 %, SR[1:0] = 01	$\Delta$ t <sub>RF_01</sub>	-50	0.0	50	$\mu$ s
Turn-ON and Turn-OFF Delay time matching (t <sub>DLY(ON)</sub> - t <sub>DLY(OFF)</sub> ) f <sub>PWM</sub> = 1.0 kHz, $16\text{ V} < V_{PWR} < 36\text{ V}$ , duty cycle on IN[x] = 50 %, SR[1:0] = 10	$\Delta$ t <sub>RF_10</sub>	-13	0.0	13	$\mu$ s

**Notes**

27. Rising and Falling edge slew rates specified for a 20 to 80% voltage variation on a 5.0  $\Omega$  resistive load (see Figure 4).
28. Turn-on delay time measured as delay between a rising edge of the channel control signal (IN[0:1] = 1 or CSB) and the associated rising edge of the output voltage up to:  $V_{HS[0:1]} = V_{PWR} / 2$  (where  $R_L = 5.0\text{ }\Omega$ ). Turn-OFF delay time is measured as time between a falling edge of the channel control signal (IN[0:1] = 0 or CSB pin) and the associated falling edge of the output voltage up to the instant at which:  $V_{HS[0:1]} = V_{PWR} / 2$  ( $R_L = 5.0\text{ }\Omega$ )

**Table 4. Dynamic Electrical Characteristics (continued)**

Unless specified otherwise:  $8.0\text{ V} \leq V_{PWR} \leq 36\text{ V}$ ,  $3.0\text{ V} \leq V_{DD} \leq 5.5\text{ V}$ ,  $-40\text{ }^\circ\text{C} \leq T_A \leq 125\text{ }^\circ\text{C}$ ,  $\text{GND} = 0\text{ V}$ . Typical values are average values evaluated under nominal conditions  $T_A = 25\text{ }^\circ\text{C}$ ,  $V_{PWR} = 28\text{ V}$  &  $V_{DD} = 5.0\text{ V}$ , unless specified otherwise.

Parameter	Symbol	Min	Typ	Max	Unit
<b>SWITCHING CHARACTERISTICS (CONTINUED)</b>					
Delay time difference from one channel to the other in parallel mode <sup>(29)</sup> $16\text{ V} < V_{PWR} < 36\text{ V}$ SR[1:0] = 00 SR[1:0] = 01 SR[1:0] = 10	$\Delta t_{(DLY)}$	-40 -21 -11	0.0 0.0 0.0	+40 +21 +11	$\mu\text{s}$
Fault Detection Delay Time <sup>(30)</sup>	$t_{FAULT}$	–	5.0	8.0	$\mu\text{s}$
Output Shutdown Delay Time <sup>(31)</sup>	$t_{DETECT}$	–	7.0	12	$\mu\text{s}$
Current sense output settling Time for SR[1:0] = 00 (medium slew rate) <sup>(31)</sup> $16\text{ V} < V_{PWR} < 36\text{ V}$	$t_{CSNSVAL\_00}$	0.0	–	210	$\mu\text{s}$
Current sense output settling Time for SR[1:0] = 01 (low slew rate) <sup>(31)</sup> $16\text{ V} < V_{PWR} < 36\text{ V}$	$t_{CSNSVAL\_01}$	0.0	–	310	$\mu\text{s}$
Current sense output settling Time for SR[1:0] = 10 (high slew rate) <sup>(31)</sup> $16\text{ V} < V_{PWR} < 36\text{ V}$	$t_{CSNSVAL\_10}$	0.0	–	175	$\mu\text{s}$
SYNC output signal delay for SR[1:0] = 00 (medium SR) <sup>(31)</sup>	$t_{SYNCVAL\_00}$	50	–	150	$\mu\text{s}$
SYNC output signal delay for SR[1:0] = 01 (low SR) <sup>(31)</sup>	$t_{SYNCVAL\_01}$	80	–	290	$\mu\text{s}$
SYNC output signal delay for SR[1:0] = 10 (high SR) <sup>(32)</sup>	$t_{SYNCVAL\_10}$	24	–	80	$\mu\text{s}$
Recommended sync_to_read delay SR[1:0] = 00 (medium slew rate) <sup>(31)</sup>	$t_{SYNREAD\_00}$	–	–	200	$\mu\text{s}$
Recommended sync_to_read delay SR[1:0] = 01 (low slew rate) <sup>(31)</sup>	$t_{SYNREAD\_01}$	–	–	200	$\mu\text{s}$
Recommended sync_to_read delay SR[1:0] = 10 (high slew rate) <sup>(31)</sup>	$t_{SYNREAD\_10}$	–	–	200	$\mu\text{s}$
Upper over-current threshold duration	$t_{OCH1}$ $t_{OCH2}$	6.0 12.0	8.6 17.2	11.2 22.4	ms
Medium over-current threshold duration (CONF = 0; Lighting Profile)	$t_{OCM1\_L}$ $t_{OCM2\_L}$	48 96	67 137	87 178	ms
Medium over-current threshold duration (CONF = 1; DC motor Profile)	$t_{OCM1\_M}$ $t_{OCM2\_M}$	96 245	137 350	178 455	ms

**FREQUENCY & PWM DUTY CYCLE RANGES**<sup>(33)</sup> (protections fully operational, see [Protective Functions](#))

Switching Frequency range - Direct Inputs	$f_{CONTROL}$	0.0	–	1000	Hz
Switching Frequency range - External clock with internal PWM (recommended)	$f_{PWM\_EXT}$	20	–	1000	Hz
Switching Frequency range - Internal clock with internal PWM (recommended)	$f_{PWM\_INT}$	60	–	1000	Hz
Duty Cycle range	$R_{CONTROL}$	0.0	–	100	%

**Notes:**

29. Rising and Falling edge slew rates specified for a 20 to 80% voltage variation on a 5.0  $\Omega$  resistive load (see [Figure 4](#)).
30. Time required to detect and report the fault to the FSB pin.
31. Time required to switch off the channel after detection of over-temperature (OT), over-current (OC), SC or UV error (time measured between start of the negative edge on the FSB pin and the falling edge on the output voltage until  $V(HS[0:1]) = 50\%$  of  $V_{PWR}$ ).
32. Settling time ( $= t_{CSNSVAL\_xx}$ ), SYNC output signal delay ( $= t_{SYNCVAL\_xx}$ ) and Read-out delay ( $= t_{SYNREAD\_xx}$ ) are defined for a stepped load current ( $100\text{ mA} < I(LOAD) < IOCLX\text{ A}$  FOR  $CSNS\_RATIO\_S = 1$ , AND  $300\text{ mA} < I(LOAD) < IOCLX\text{ A}$  FOR  $CSNS\_RATIO\_S = 0$ ). (see [Figure 8](#) and [Output Current Monitoring \(CSNS\)](#))
33. In Direct Input mode, the lower frequency limit is 0 Hz with  $RSTB=5.0\text{ V}$  and 4.0 Hz with  $RSTB=0\text{ V}$ . Duty-cycle applies to instants at which  $V_{HS} = 50\% V_{PWR}$ . For low duty cycle values, the effective value will also depend on the value of the selected slew rate.



**Table 4. Dynamic Electrical Characteristics (continued)**

Unless specified otherwise:  $8.0\text{ V} \leq V_{PWR} \leq 36\text{ V}$ ,  $3.0\text{ V} \leq V_{DD} \leq 5.5\text{ V}$ ,  $-40\text{ }^\circ\text{C} \leq T_A \leq 125\text{ }^\circ\text{C}$ ,  $\text{GND} = 0\text{ V}$ . Typical values are average values evaluated under nominal conditions  $T_A = 25\text{ }^\circ\text{C}$ ,  $V_{PWR} = 28\text{ V}$  &  $V_{DD} = 5.0\text{ V}$ , unless specified otherwise.

Parameter	Symbol	Min	Typ	Max	Unit
<b>AVAILABILITY DIAGNOSTIC FUNCTIONS OVER DUTY-CYCLE AND SWITCHING FREQUENCY</b> (protection & diagnostics both fully operational, see <a href="#">Diagnostic Features</a> for the exact boundary values)					
Available Duty Cycle Range, $f_{PWM} = 1.0\text{ kHz}$ high slew rate <sup>(34)</sup> OL_OFF OL_ON OS	$R_{PWM\_1K\_H}$	0.0 35 0.0	– – –	62 100 90	%
Available Duty Cycle Range, $f_{PWM} = 400\text{ Hz}$ , medium slew rate mode <sup>(34)</sup> OL_OFF OL_ON OS	$R_{PWM\_400\_M}$	0.0 21 0.0	– – –	81 100 88	%
Available Duty Cycle Range, $f_{PWM} = 400\text{ Hz}$ , high slew rate mode <sup>(34)</sup> OL_OFF OL_ON OS	$R_{PWM\_400\_H}$	0.0 14 0.0	– – –	84 100 95	%
Available Duty Cycle Range, $f_{PWM} = 200\text{ Hz}$ , low slew rate mode <sup>(34)</sup> OL_OFF OL_ON OS	$R_{PWM\_200\_L}$	0.0 15 0.0	– – –	86 100 93	%
Available Duty Cycle Range, $f_{PWM} = 200\text{ Hz}$ , medium slew rate mode <sup>(34)</sup> OL_OFF OL_ON OS	$R_{PWM\_200\_M}$	0.0 11 0.0	– – –	90 100 94	%
Available Duty Cycle Range, $f_{PWM} = 100\text{ Hz}$ in low slew rate mode <sup>(34)</sup> OL_OFF OL_ON OS	$R_{PWM\_100\_L}$	0.0 8.0 0.0	– – –	93 100 96	%
Deviation of the internal clock PWM frequency after Calibration <sup>(35)</sup>	$A_{FPWM(CAL)}$	-10	–	+10	%
Default output frequency when using an uncalibrated oscillator	$f_{PWM(0)}$	280	400	520	Hz
Minimal required Low Time during Calibration of the Internal Clock through CSB	$t_{CSB(MIN)}$	1.0	1.5	2.0	$\mu\text{s}$
Maximal allowed Low Time during Calibration of the Internal Clock through CSB	$t_{CSB(MAX)}$	70	100	130	$\mu\text{s}$
Recommended external Clock Frequency Range (external clock/PWM Module)	$f_{CLOCK}$	15	–	512	kHz
Upper detection threshold for external Clock frequency monitoring	$f_{CLOCK(MAX)}$	512	730	930	kHz
Lower detection threshold for external Clock frequency monitoring	$f_{CLOCK(MIN)}$	5.0	7.0	10	kHz

**TIMING: SPI PORT, IN[0]/ IN[1] SIGNALS & AUTORETRY**

Required Low time allowing delatching or triggering sleep mode (direct inputs)	$t_{IN}$	175	250	325	ms
Watchdog Timeout for entering Fail-safe Mode due to loss of SPI contact <sup>(36)</sup>	$t_{WDTO}$	217	310	400	ms
Auto-Retry Repetition Period (when activated): Auto_period bits = 00 Auto_period bits = 01 Auto_period bits = 10 Auto_period bits = 11	$t_{AUTO\_00}$ $t_{AUTO\_01}$ $t_{AUTO\_10}$ $t_{AUTO\_11}$	105 52.5 26.2 13.1	150 75 37.5 17.7	195 97.5 47.8 24.4	ms

**Table 4. Dynamic Electrical Characteristics (continued)**

Unless specified otherwise:  $8.0\text{ V} \leq V_{PWR} \leq 36\text{ V}$ ,  $3.0\text{ V} \leq V_{DD} \leq 5.5\text{ V}$ ,  $-40\text{ }^\circ\text{C} \leq T_A \leq 125\text{ }^\circ\text{C}$ ,  $\text{GND} = 0\text{ V}$ . Typical values are average values evaluated under nominal conditions  $T_A = 25\text{ }^\circ\text{C}$ ,  $V_{PWR} = 28\text{ V}$  &  $V_{DD} = 5.0\text{ V}$ , unless specified otherwise.

Parameter	Symbol	Min	Typ	Max	Unit
<b>GND PIN TEMPERATURE SENSING FUNCTION</b>					
Thermal Prewarning Detection Threshold <sup>(37)</sup>	T <sub>OTWAR</sub>	110	125	140	°C
Temperature Sensing output voltage @ T <sub>A</sub> = 25 °C (470 Ω < R <sub>CSNS</sub> < 10 kΩ)	T <sub>FEED</sub>	918	1078	1238	mV
Gain Temperature Sensing output @ T <sub>A</sub> = 25 °C (470 Ω < R <sub>CSNS</sub> < 10 kΩ) <sup>(37)</sup>	DT <sub>FEED</sub>	10.7	11.1	11.5	mV/°C
Temperature Sensing Error, range [-40 °C, 150 °C], default <sup>(37)</sup>	T <sub>FEED_ERROR</sub>	-15	–	+15	°C
Temperature Sensing Error, [-40 °C, 150 °C] after 1 point calibration @ 25 °C <sup>(37)</sup>	T <sub>FEED_ERROR_CAL</sub>	-5.0	–	+5.0	°C

**Notes:**

34. The device can be operated outside the specified duty cycle and frequency ranges (basic protective functions OC, SC, UV, OV, and OT remain active), but the availability of the diagnostic functions OL\_ON, OL\_OFF, and OS is affected. OL\_OFF duty-cycle range is guaranteed by design characterization.
35. Values guaranteed from 60 Hz to 1.0 kHz (recommended switching frequency range).
36. Only when the WD\_dis bit set to logic [0] (default). Watchdog timeout defined from the rising edge on RST to rising edge HS[0,1]
37. values were obtained after lab characterization

**Table 4. Dynamic Electrical Characteristics (continued)**

Unless specified otherwise:  $8.0\text{ V} \leq V_{PWR} \leq 36\text{ V}$ ,  $3.0\text{ V} \leq V_{DD} \leq 5.5\text{ V}$ ,  $-40\text{ }^\circ\text{C} \leq T_A \leq 125\text{ }^\circ\text{C}$ ,  $\text{GND} = 0\text{ V}$ . Typical values are average values evaluated under nominal conditions  $T_A = 25\text{ }^\circ\text{C}$ ,  $V_{PWR} = 28\text{ V}$  &  $V_{DD} = 5.0\text{ V}$ , unless specified otherwise.

Parameter	Symbol	Min	Typ	Max	Unit
<b>SPI INTERFACE ELECTRICAL CHARACTERISTICS<sup>(38)</sup></b>					
Maximum Operating Frequency of the Serial Peripheral Interface (SPI) <sup>(44)</sup>	$f_{\text{SPI}}$	–	–	8.0	MHz
Required Low-state Duration for reset RSTB <sup>(39)</sup>	$t_{\text{WRSTB}}$	10	–	–	$\mu\text{s}$
Required duration from the Rising to the Falling Edge of CSB (Required Setup Time) <sup>(40)</sup>	$t_{\text{CSB}}$	1.0	–	–	$\mu\text{s}$
Rising Edge of RSTB to Falling Edge of CSB (Required Setup Time) <sup>(40)</sup>	$t_{\text{ENBL}}$	5.0	–	–	$\mu\text{s}$
Falling Edge of CSB to Rising Edge of SCLK (Required Setup Time) <sup>(40)</sup>	$t_{\text{LEAD}}$	500	–	–	ns
Required High State Duration of SCLK (Required Setup Time) <sup>(40)</sup>	$t_{\text{WSCLKh}}$	50	–	–	ns
Required Low State Duration of SCLK (Required Setup Time) <sup>(40)</sup>	$t_{\text{WSCLKl}}$	50	–	–	ns
Falling Edge of SCLK to Rising Edge of CSB (Required Setup Time) <sup>(40)</sup>	$t_{\text{LAG}}$	60	–	–	ns
SI to Falling Edge of SCLK (Required Setup Time) <sup>(41)</sup>	$t_{\text{SI(SU)}}$	37	–	–	ns
Falling Edge of SCLK to SI (Required Setup Time) <sup>(41)</sup>	$t_{\text{SI(HOLD)}}$	49	–	–	ns
SO Rise Time $C_L = 80\text{ pF}$	$t_{\text{RSO}}$	–	–	20	ns
SO Fall Time $C_L = 80\text{ pF}$	$t_{\text{FSO}}$	–	–	20	ns
SI, CSB, SCLK, Max. Rise Time allowing operation at $f_{\text{SPI}} = 8.0\text{ MHz}$ <sup>(41)</sup>	$t_{\text{RSI}}$	–	–	12	ns
SI, CSB, SCLK, Max. Fall Time allowing operation at $f_{\text{SPI}} = 8.0\text{ MHz}$ <sup>(41)</sup>	$t_{\text{FSI}}$	–	–	12	ns
Time from Rising Edge of SCLK to the SO Low-level <sup>(42)</sup>	$t_{\text{SO(EN)}}$	–	–	73	ns
Time from Rising Edge of SCLK to the SO High-level <sup>(43)</sup>	$t_{\text{SO(DIS)}}$	–	–	73	ns

**Notes**

38. Parameters guaranteed by design. It is recommended to tie unused SPI pins to GND with resistors  $1.0\text{k} < R < 10\text{ k}$
39. RSTB low duration defined as the minimum time required to switch off the channel when previously put ON in SPI mode (direct inputs inactive).
40. Minimum setup time required for the device is the minimum required time that the microcontroller must wait or remain in a given state.
41. Rise and Fall time of incoming SI, CSB, and SCLK signals.
42. Time required for output data to be available for use at SO, measured with a  $1.0\text{ k}\Omega$  series resistor connected CSB.
43. Time required for output data to be terminated at SO measured with a  $1.0\text{ k}\Omega$  series resistor connected CSB.
44. For clock frequencies  $> 4.0\text{ MHz}$ , series resistors on the SPI pins should preferably be removed. Otherwise,  $470\text{ pF}$  ( $V_{\text{MAX}} > 40\text{ V}$ ) ceramic speed-up capacitors in parallel with the  $>8.0\text{ k}\Omega$  input resistors are required on pins SCLK, SI, SO, and CS.

TIMING DIAGRAMS

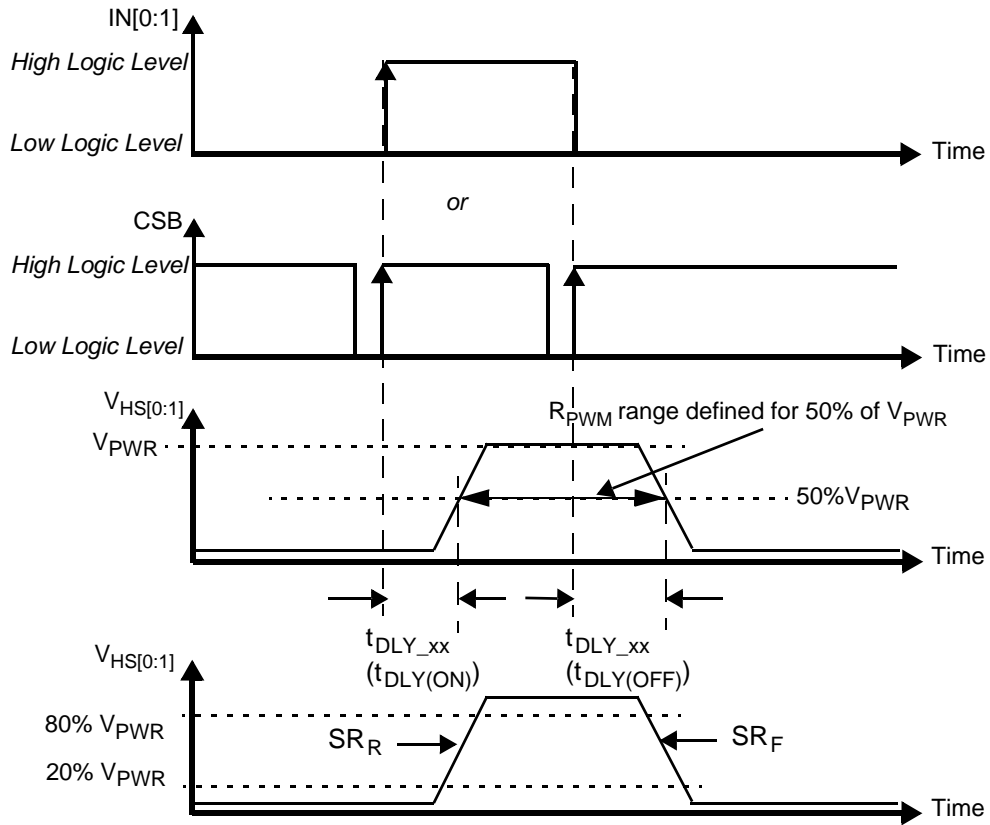

Figure 4. Output Voltage Slew Rate and Delay

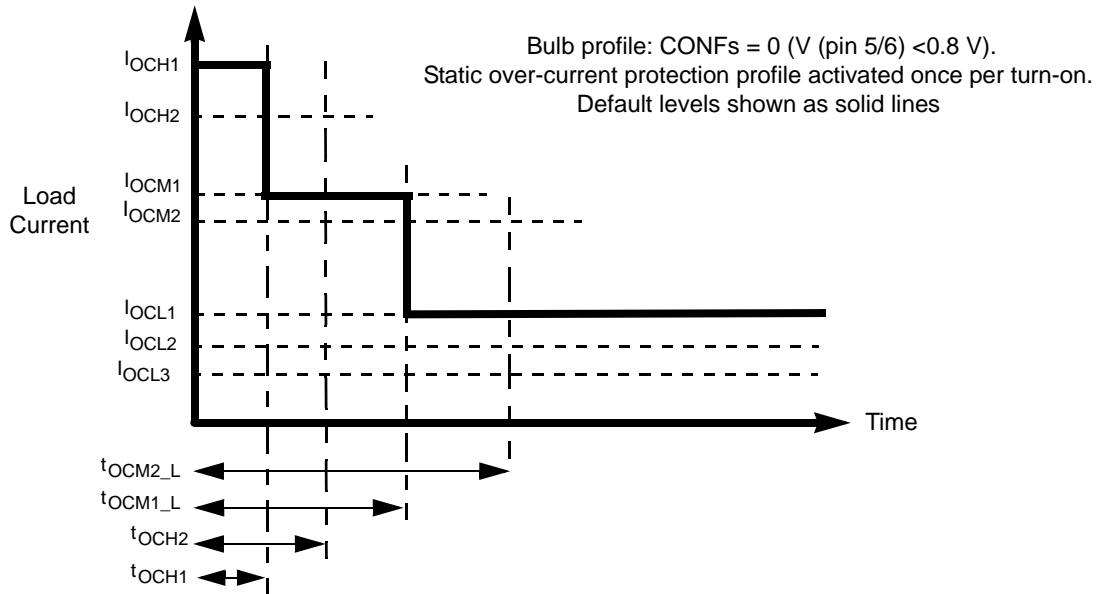

Figure 5. Over-current Protection Profile for Bulb Applications

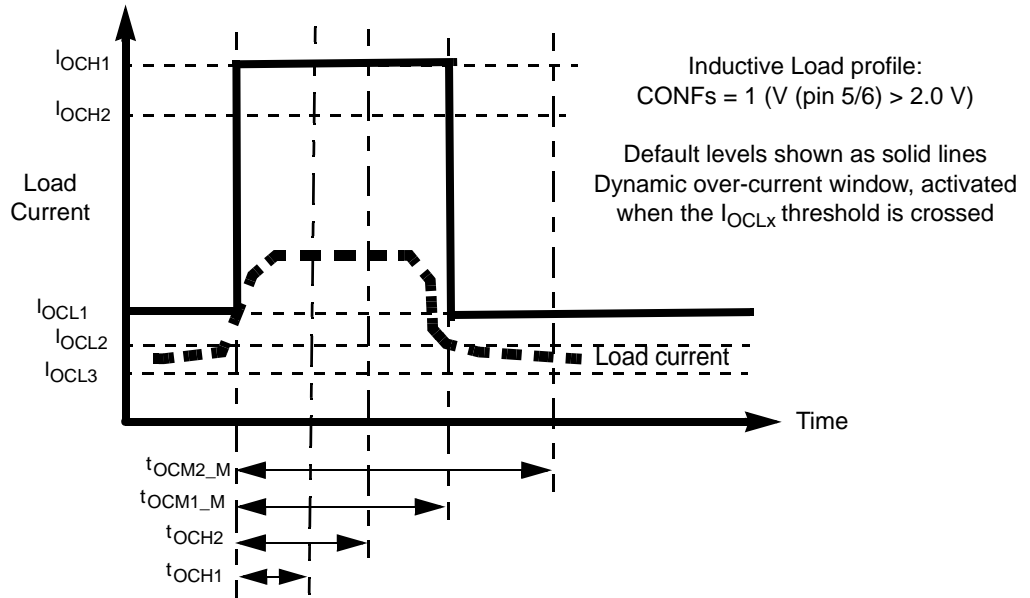

Figure 6. Over-current Protection Profile for Applications with Inductive Loads (DC motors, solenoids)

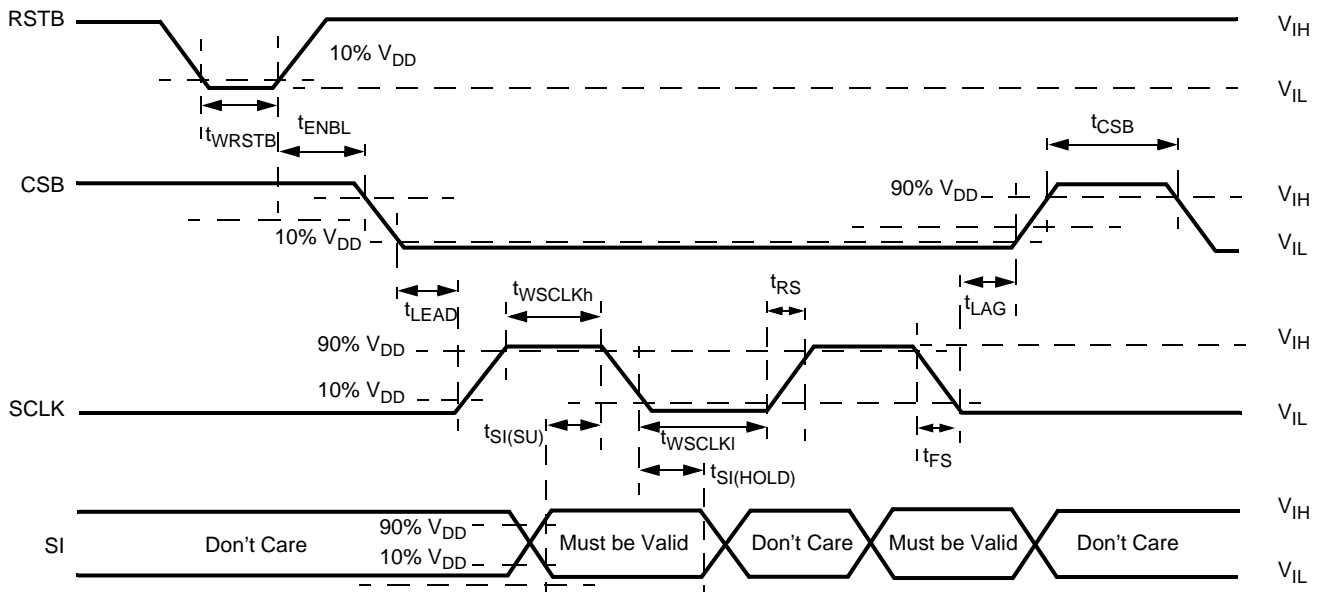

Figure 7. Timing Requirements During SPI Communication

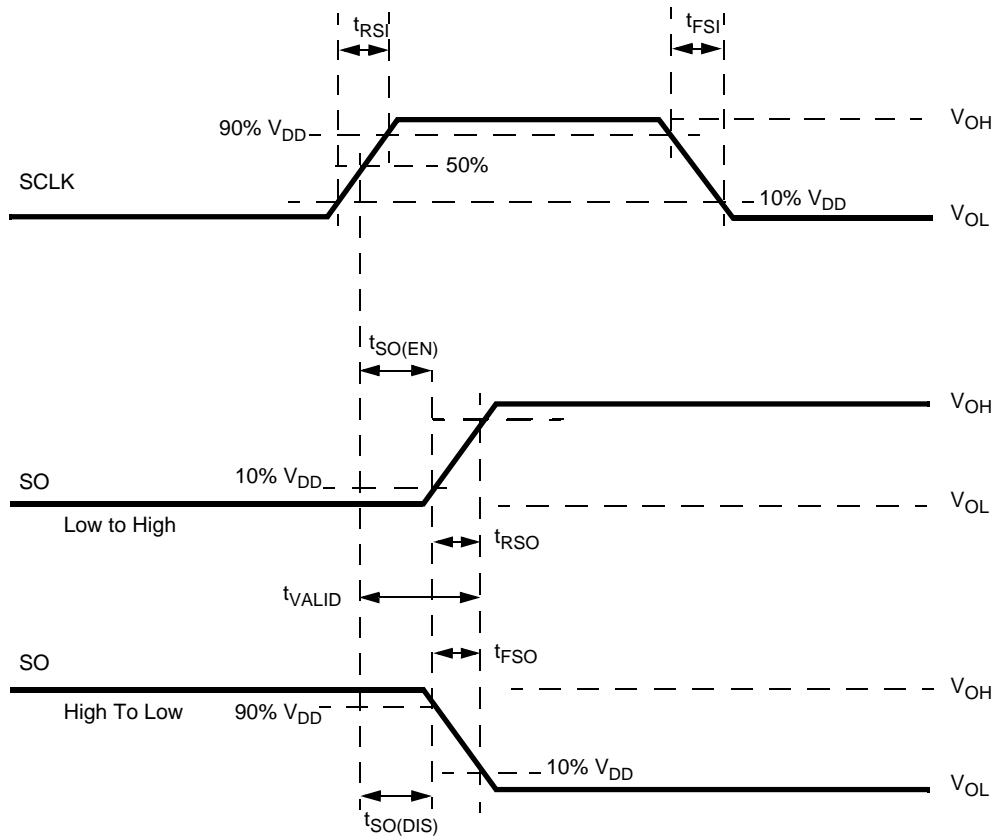

Figure 8. Timing Diagram for Serial Output (SO) Data Communication

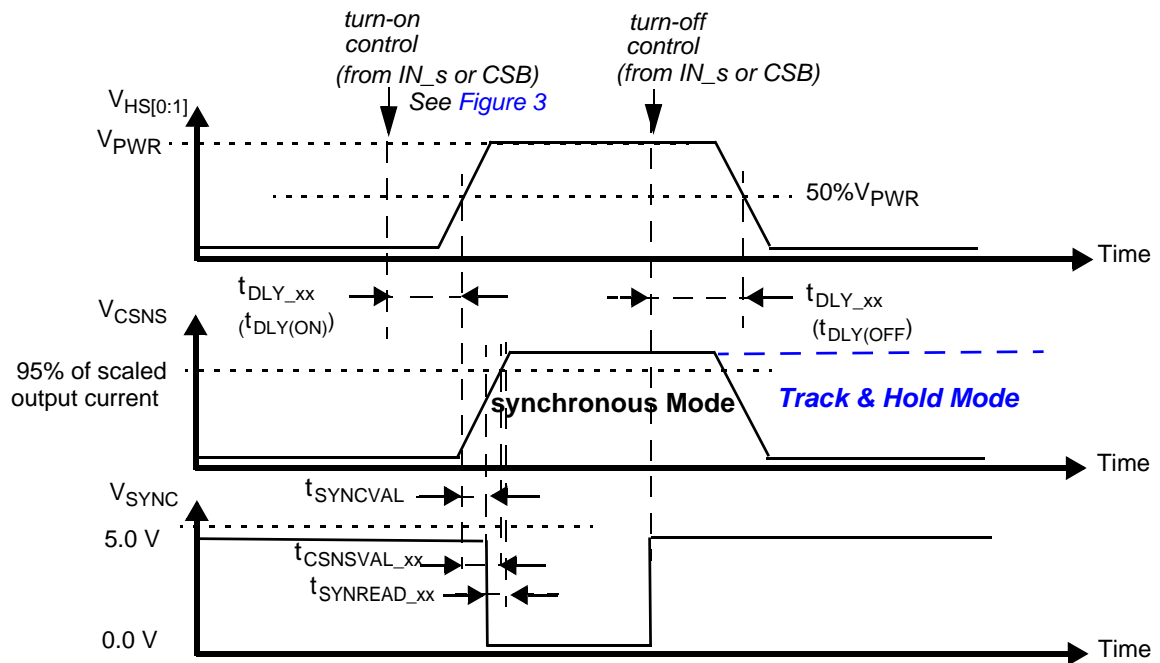

Figure 9. Synchronous & Track-and-Hold Current Sensing Modes: Associated Delay & Settling Times

## FUNCTIONAL DESCRIPTION

### INTRODUCTION

The 10XS4200 is a two-channel, 24 V high side switch with integrated control and diagnostics designed for truck, bus, and industrial applications. The device provides a high number of protective functions. Both low  $R_{DS(ON)}$  channels ( $<10\text{ m}\Omega$ ) can independently drive various load types like light bulbs, solenoid actuators, or DC motors. Device control and diagnostics are configured through a 16-bit SPI port with daisy-chain capability.

Independently programmable output voltage slew rates allow satisfying electromagnetic compatibility (EMC) requirements.

Both channels can independently be operated in three different switching modes: internal clock, internal PWM mode (fully autonomous operation), external clock, internal PWM mode, and direct control switching mode.

Current sensing with an adjustable ratio is available on both channels, allowing both high-current (bulbs) and low-current (LED) monitoring. By activating the Track & Hold mode, current monitoring can be performed during the switch-Off phase. This allows random access to the current sense functionality. A patented offset compensation technique further enhances current sense accuracy.

To avoid turning off upon inrush current, while being able to monitor it, the device features a dynamic over-current threshold profile. For bulbs, this profile is a stair function with stages of which the height and width are programmable through the SPI port. DC motors can be protected from overheating by activating a specific window-shaped over-current profile that allow stall currents of limited duration.

Whenever communication with the external micro-controller is lost, the device enters Fail-safe Operation mode, but remains operational, controllable and protected.

### PIN ASSIGNMENT AND FUNCTIONS

All logic input and output “pins” must be protected by series resistors of at least 1.0 k $\Omega$ , unless specified otherwise. Functions and register bits that are implemented independently for both channels have extension “\_s”.

#### OUTPUT CURRENT MONITORING (CSNS)

The CS pin allows independent current monitoring of channel 0 or channel 1 up to the steady-state over-current threshold. It can also be used to sense the device temperature. The different functions are selected by setting bits CSNS1\_en and CSNS0\_en to the appropriate value (Table 21). When the CSNS pin is sensed during switch-off in the (optional) track & hold mode (see Figure 8), it will output the scaled value of the load current as it was just before turn-Off. When several devices share the same pull-down resistor, the CSNS pins of devices, the current of which is not monitored, must be tri-stated. This is accomplished by setting CSNS0\_en = 0 and CSNS1\_en = 0 in their GCR register (Table 11). Settling time ( $t_{CSNSVAL\_XX}$ ) is defined as the time between the instant at the middle of the output voltage's rising edge ( $HS[0:1] = 50\%$  of  $V_{PWRR}$ ), and the instant at which the voltage on the CSNS pin has settled to  $\pm 5.0\%$  of its final value. Anytime an over-current window is active, the CSNS pin is disabled (see [Over-current Detection on Resistive and Inductive Loads](#)). The current and temperature sensing functions are unavailable in Fail-safe mode and in Normal mode when operating without the  $V_{DD}$  supply voltage. In order to generate a voltage output, this pin requires a pull-down resistor ( $R(CSNS)=1.0\text{ k}\Omega$  typ. and  $470 < R(CSNS) < 10\text{ k}$ ). When the current sense resistor connected to the CSNS pin is disconnected, the CSNS voltage is clamped to  $V_{CL(CSNS)}$ . The CSNS pin can source currents up to about 5.6 mA.

#### CURRENT SENSE SYNCHRONIZATION (SYNC)

To synchronize current sensing with an external process, the SYNC signal can be connected to a digital input of an external MCU. An open-drain pull-down on SYNC indicates that the current sense signal is accurate and ready to be read. The current sense signal on the CSNS pin has the specified accuracy  $t_{SYNREAD\_XX}$  seconds after the falling edge on the SYNC pin (Figure 9) and remains valid until a rising edge is generated. The rising edge that is generated by the SYNC pin at the turn-OFF instant (internal or external) may also be used to implement synchronization with the external MCU. Parameter  $t_{SYNVAL\_XX}$  is defined as the time between the instant at the middle of the output voltage rising edge ( $HS[0:1] = 50\%$  of  $VPWR$ ), and the instant at which the voltage on the SYNC-pin drops below 0.4 V ( $V_{SOL}$ ). The SYNC pins of different devices can be connected together to save micro-controller input channels. However, in this configuration, the CSNS of only one device should be active at a time. Otherwise, the MCU will not be able to determine the source of the SYNC signal. The SYNC pin requires an external pull-up resistor to  $V_{DD}$ .

#### DIRECT CONTROL INPUTS (IN0 AND IN1)

The IN[0:1] pins allow direct control of both channels. A logic [0] level turns off the channel and a logic[1] level turns it on (Parallel Operation). When the device is in Sleep mode, a transition from logic 0 to logic 1 on any of these pins will wake it up (Channel configuration through the SPI). If it is desired to automatically turn on the channels after a transition to Fail-safe mode, inputs IN[0] and IN[1] must be externally connected to the VPWR pin by a pull-up resistor (e.g. 10 k $\Omega$  typ.). However, this will prevent the device from going into

Sleep mode. Both IN pins are internally connected to a pull-down resistor.

### CONFIGURATION INPUTS (CONF0 AND CONF1)

The CONF[0:1] input pins allow configuring both channels for the appropriate load type. CONF = 0 activates the bulb over-current protection profile, and CONF = 1 the DC motor profile. These inputs are connected to an internal voltage regulator of 3.3 V by an internal pull-up current source  $I_{UP}$ . Therefore, CONF = 1 is the default value when these pins are disconnected. Details on how to configure the channels are given in the table [Over-current Profile Selection](#).

### FAULT STATUS (FSB)

This open-drain output is asserted low when any of the following faults occurs (see [Fault Mode](#)): over-current (OC), over-temperature (OT), output connected to  $V_{PWR}$ , severe short-circuit (SC), open-load in ON state (OL\_ON), open-load in OFF state (OL\_OFF), external clock-fail (CLOCK\_fail), over-voltage (OV), under-voltage (UV). Each fault type has its own assigned bit inside the STATR, FAULTR\_s, or DIAGR\_s register. Fault type identification and fault bit reset are accomplished by reading out these registers. The registers are part of the SO register ([Table 22](#)), and are accessed through the SPI port.

### PWM CLOCK (CLOCK)

This pin is the input for an external clock signal that controls the internal PWM Module. The clock signal is monitored by the device. The PWM module controls ON-time and turn-ON delay of the selected channels. The CLOCK pin should not be confused with the SCLK pin, which is the clock pin of the SPI interface. CLOCK has an internal pull-down current source ( $I_{DWN}$ ) to GND.

### RESET (RSTB)

All SPI register contents are reset when RSTB = 0. When RSTB = 0, the device returns to Sleep mode  $t_{IN}$  sec. after the last falling edge of the last active IN[0:1] signal. As long as the Reset input (RSTB pin) is at logic 0 and both direct input states remain low, the device remains in Sleep mode ([Channel configuration through the SPI](#)). A 0-to-1 transition on RSTB wakes the device and starts a watchdog timer to check the continuous presence of the SPI signals. To do this, the device monitors the contents of the first bit (WDIN bit) of all SPI words, following that transition (regardless the register it is contained in). When this contents is not alternated within a duration  $t_{WDTO}$ , SPI communication is considered lost, and Fail-safe mode is entered ([Entering Fail-safe Mode](#)). RSTB pin is internally pulled to GND by a  $R_{DWN}$  resistor.

### CHIP SELECT (CSB)

Data communication over the SPI port is enabled when the CSB pin is in the logic [0] state. Data from the Input Shift registers are locked in the addressed SI registers on the rising edge of CSB. The device transfers the contents of one of the eight internal registers to the SO register on the falling

edge of CSB. The SO output driver is enabled when CSB is logic [0]. CSB should transition from a logic [1] to a logic [0] state only when SCLK is at logic [0]. CSB is internally pulled up to  $V_{DD}$  through  $I_{UP}$ . (see [Figure 6](#) and [Figure 8](#))

### SPI SERIAL CLOCK (SCLK)

The SCLK pin clocks the SPI data communication of the device. The serial input pin (SI) transfers data to the SI shift registers on the falling edge of the SCLK signal while data in the SO registers are transferred to the SO pin on the rising edge of the SCLK signal. The SCLK pin must be in low state when CSB makes any transition. For this reason, it is recommended to have the SCLK pin at a logic [0] state when the device is not accessed (CSB logic [1] state). When CSB is set to logic [1], signals at the SCLK and SI pins are ignored and the SO output is tri-stated (high-impedance). The SCLK pin is connected to an internal pull-down current source  $I_{DWN}$ .

### SERIAL INPUT (SI)

Serial input (SI) data bits are shifted in at this pin. SI data is read on the falling edge of SCLK. 16-bit data packages are required on the SI pin (see [Figure 7](#)), starting with bit D15 (MSB) and ending with D0 (LSB). All the internal device registers are addressed and controlled by a 4-bit address (D9-D12) described in [Table 10](#). Register addresses and function attribution are described in [Table 11](#). The SI pin is internally connected to a pull-down current source,  $I_{DWN}$ .

### SUPPLY OF THE DIGITAL CIRCUITRY (VDD)

This pin supplies the SPI circuit (3.3 V or 5.0 V). When lost, all circuitry is supplied by a  $V_{PWR}$  derived voltage, except the SPI's SO shift-register, which can no longer be read.

### GROUND (GND)

This is the GND pin common for both the SPI and the other circuitry.

### POSITIVE SUPPLY PIN (VPWR)

This pin is the positive supply and the common input pin of both switches. A 100 nF ceramic capacitor must be connected between VPWR and GND, close to the device. In addition, it is recommended to place a ceramic capacitor of at least 1.0  $\mu$ F in parallel with this 100 nF capacitor.

### SERIAL OUTPUT (SO)

The SO pin is a tri-stateable output pin that conveys data from one of the 13 internal SO registers, or from the previous SI register, to the outside world. The SO pin remains in a high-impedance state (tri-state) until the CSB pin becomes logic [0]. It then transfers the SPI data (device state, configuration, fault information). The SO pin changes state at the rising edge of the SCLK signal. For daisy-chaining, it can be read out on the falling edge of SCLK.  $V_{DD}$  must be present before the SO registers can be read. The SO register assignment is described in [Table 22](#).



## OUTPUT PINS (HS0 AND HS1)

HS0 and HS1 are the output pins of the power switches to be connected to the loads. A ceramic  $\leq 22$  nF (+/- 20%) capacitor is recommended between these pins and GND for optimal EMC performances.

## FAIL-SAFE OUTPUT (FSOB)

This pin (active low) is used to indicate loss of SPI communication or loss of SPI supply voltage,  $V_{DD}$ . This open-drain output requires an external pull-up resistor to VPWR.

### FUNCTIONAL INTERNAL BLOCK DESCRIPTION

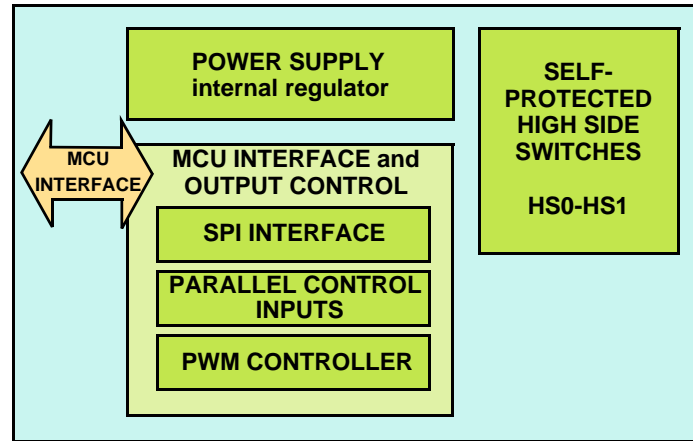

## POWER SUPPLY

The device will operate with supply voltages from 6.0 to 58 V ( $V_{PWR}$ ), but will be full spec. compliant only between 8.0 and 36 V. The VPWR pin supplies power to the internal regulator, analog, and logic circuit blocks. The VDD pin (5.0 V typ.) supplies the output register of the Serial Peripheral Interface (SPI). Consequently, the SPI registers cannot be read without presence of  $V_{DD}$ . The employed IC architecture guarantees a low quiescent current in Sleep mode.

## SWITCH OUTPUT PINS HS0 & HS1

HS0 and HS1 are the output pins of the power switches. Both channels are protected against various kinds of short-circuits and have active clamp circuitry that may be activated when switching off inductive loads. Many protective and diagnostic functions are available. For large inductive loads, it is recommended to use a freewheeling diode. The device can be configured to control the output switches in parallel, which guarantees good switching synchronization.

## COMMUNICATION INTERFACE AND DEVICE CONTROL

In Normal mode the output channels can either be controlled by the direct inputs or by the internal PWM module, which is configured by the data stored in the SPI registers. For bidirectional SPI communication,  $V_{DD}$  has to be in the authorized range. Failure diagnostics and configurations are also performed through the SPI port. The reported failure types are: open-load, short-circuit to battery, severe short-circuit to ground, over-current, over-temperature, clock-fail, and under and over-voltage. The SPI port can be supplied either by a 5.0 V or by a 3.3 V voltage supply. For direct input control,  $V_{DD}$  is not required.

A Pulse Width Modulation (PWM) circuit allows driving loads at frequencies up to 1.0 kHz from an external or an internal clock. SPI communication is required to set these options.

## FUNCTIONAL DEVICE OPERATION

### OPERATION AND OPERATING MODES

The device possesses two high side switches (channels) each of which can be controlled independently. The device has four fundamental operating modes: Sleep, Normal, Fail-safe, and Fault mode, as shown in [Table 5](#).

Each channel can be controlled in three different ways in Normal mode: by a signal on the Direct Input pin, by an internal clock signal (autonomous operation) or by an external clock signal. For bidirectional SPI communication, a second supply voltage is required ( $V_{DD} = 5.0\text{ V}$  or  $3.3\text{ V}$ ). When only the direct inputs  $IN[x]$  are used,  $V_{DD}$  isn't required.

#### DEVICE START-UP SEQUENCE

To put the device in a known configuration and guarantee predictable behavior, the device must undergo a wake-up sequence. However, it should not be woken up earlier than the moment at which  $V_{PWR}$  has exceeded its under-voltage threshold,  $V_{PWR}(UV)$ , and  $V_{DD}$  has exceeded its supply failure threshold,  $V_{DD}(FAIL)$ . In applications using the SPI port, the device is typically put in wake mode by setting  $RSTB=1$ . Wake-up of applications with direct input control can be achieved by having signals  $IN\_ON[0] = 1$  or  $IN\_ON[1] = 1$  (see [Figure 10](#)). After wake-up, all SPI register contents are reset and Normal mode is entered (as defined in [Table 11](#) and [Table 22](#)). All the device functions will be available 50  $\mu\text{s}$  later (typically).

If the start-up sequence is not performed at device start-up, its configuration may be undetermined and correct operation is not guaranteed. In situations where the above described start-up sequence can not be performed, it is recommended to generate a wake-up event after the moment  $V_{PWR}$  has reached the under-voltage threshold.

#### CHANNEL CONFIGURATION THROUGH THE SPI

##### Setting the Channel Configuration

The channel configuration is determined by the contents of the pulse-width ( $PWMR\_s$ ), the configuration ( $CONFR\_s$ ) and the over-current ( $OCR\_s$ ) registers. They allow setting, among others, the following parameters: duty-cycle, delay, Slew Rate, PWM enable ( $PWM\_en$ ), clock selection ( $CLOCK\_sel$ ), prescaler ( $PR$ ), and direct\_input disable ( $DIR\_dis$ ). Extension “\_s” means that these registers exist for each of both channels. Function assignment is described in detail in the section [SI Register Addressing](#)

##### Reading Back the Channel's Status and Settings

The channel's global switching and operating states (On/Off, normal/fault) are all contained in the  $STATR$  register (see [Table 15](#)). The precise fault type can be found by reading out the  $FAULTR\_s$  and  $STATR$  registers. The channel's settings (channel configuration) can be read back by reading the

$PWMR$ ,  $CONF$ ,  $OCR$ ,  $RETRY$ ,  $GCR$ , and  $DIAG$  registers. For more information, see [Serial Output Register Assignment](#).

#### NORMAL MODE

Normal mode (bit  $NM = 1$ ) can be entered in two ways, either by driving the device through the direct inputs  $IN[x]$ , or by establishing SPI communication (requires  $RSTB = \text{high}$ ). Bidirectional SPI communication additionally requires the presence of  $V_{DD}$ . To maintain the device in Normal mode, communication must take place regularly (see [Entering and Maintaining Normal Mode](#)). The device is in Normal mode (NM) when:

- $V_{PWR}$  (and  $V_{DD}$ ) are within the normal range and
- $wake\text{-}up = 1$ , and
- $fail\text{-}safe = 0$ , and
- $fault = 0$ .

#### Channel Control in Normal Mode

In direct input mode, the channel's switching state (On/Off) basically follows the logic state of the direct input signal with the turn-on delay and slew rate specified in [Table 4](#).

In internal clock mode, the switching state is controlled by an internal clock signal ([Internal Clock & Internal PWM \(Clock\\_int\\_s bit = 1\)](#)). Frequency, slew rate, duty-cycle, and turn-on delay are programmable independently for both channels.

In external clock mode, the frequency of the external clock controls the output's PWM frequency, but slew rate, duty cycle, and turn-on delay are still programmable.

#### Factors Determining the Channel's Switching State

The switching state of a channel is defined by the instantaneous value of the output voltage. It is defined as “On” when the output voltage  $V(HS[x]) > V_{PWR}/2$  and “Off” when  $V(HS[x]) < V_{PWR}/2$ . The channel's switching state should not be confused with the device's internal channel control state  $hson[x]$  (= High Side On). Signal  $hson[x]$  defines the targeted switching state of the channel (On/Off). It is either controlled by the value of the direct input signal or by that of the internal/external clock signals combined with the SPI register settings. The value of  $hson[x]$  is given by the following boolean expression:

$$hson[x] = [(IN[x] \text{ and } \overline{DIR\_dis[x]}) \text{ or } (\text{On bit } [x] \text{ and } Duty\_cycle[x] \text{ and } PWM\_en[x] = 1) \text{ or } (\text{On bit } [x] \text{ and } PWM\_en[x] = 0)].$$

In this expression  $Duty\_cycle[x]$  represents the value of the duty cycle, set by bits D7...D0 of the  $PWMR$  register ([Table 6](#)). The channel's actual switching state may differ from the control signal's state in the following cases:

- short circuits to GND, before automatic turn-Off ( $t < t_{FAULT}$ )
- short circuits to  $V_{PWR}$  when the channel is set to Off

- $V_{PWR} < 13\text{ V}$  when open-load in Off state detection is selected and the load is actually lost
- during the turn-on transition as long as  $V(HS[x]) < V_{PWR}/2$
- during the turn-off transition as long as  $V(HS[x]) > V_{PWR}/2$

### Entering and Maintaining Normal Mode

A 0-to-1 transition on RSTB, (when both  $V_{PWR}$  and  $V_{DD}$  are present) or on any of both direct inputs IN[x] (when only supplied by  $V_{PWR}$ ), will put the device in Normal mode. If desired, the device can be operated in Normal mode without  $V_{DD}$ , but this requires that at least one of both direct inputs be regularly turned on ([Operation and Operating Modes](#)). To maintain the device in Normal mode (NM), communication must take place on a regular basis.

For SPI communication, the state of the WDIN bit must be alternated at least every 310 ms (typ.) ( $t_{WDTO}$ ), unless the WD\_disable bit is set to 1.

For direct input control, the timing requirements are shown in [Figure 10](#). A signal called IN\_ON[x] is not directly accessible to the user but is used by the internal logic circuitry to determine the device state. When no activity is detected on a direct input pin (IN[x]) for a time longer than  $t_{IN} = 250\text{ ms}$  (typ.), timeout is detected and IN\_ON[x] goes low. When this occurs on both channels, Sleep mode is entered ([Sleep Mode](#)), provided reset = RSTB = 0

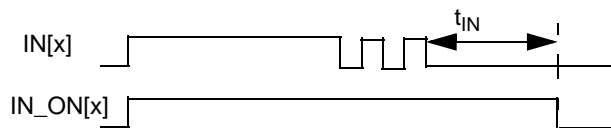

**Figure 10. Relation Between Signals IN(x) and IN\_ON[x]**

### Direct Control Mode

When RSTB = 0 (and also in Fail-safe mode), the channels are merely controlled by the direct input pins IN[x]. All protective functions (OC, OT, SC, OV, and UV) are operational including auto-retry. To avoid entering Sleep mode at frequencies < 4.0 Hz, reset should be set to RSTB = 1.

### Going from Normal to Fail-safe, Fault or Sleep Mode

The device changes from Normal to Fail-safe ([Fail-safe Mode](#)), Sleep mode ([Sleep Mode](#)), or Fault mode ([Fault Mode](#)), according to the value of the following signals (see [Table 5](#)).

- wake-up = RSTB or IN\_ON[0] or IN\_ON[1]
- fail-safe = ( $V_{DD}$  Failure and  $V_{DD\_FAIL\_en}$ ) or (SPI watchdog timeout ( $t_{WDTO}$ ) and  $WD\_DIS = 0$ )
- fault = OC[0:1] or OT[0:1] or SC[0:1] or UV or (OV and  $OV\_DISB$ )

**Table 5. Device Operating Modes**

Mode	Wake-up	Fail-safe	Fault	Comments
Sleep	0	x	x	All channels are OFF.
Normal	1	0	0	The SPI Watchdog is active when: $V_{DD} = 5.0\text{ V}$ , $WD\_DIS = 0$ , $RSTB = 1$
Fail-safe	1	1	0	The channels are controlled by the IN inputs. (see <a href="#">Fail-safe Mode</a> )
Fault	1	X	1	The channels are OFF, see <a href="#">Fault Mode</a> .

x = Don't care.

It will enter Fail-safe mode, when either a timeout on SPI communication or when  $V_{DD}$  is lost, after having been initially present (if this function was previously enabled by setting:  $V_{DD\_FAIL\_EN}$  bit = [1]). Setting watchdog disabled ( $WD\_dis = 1$ , D4 of the GCR register) avoids entering Fail-safe mode after a watchdog timeout. Device behavior upon fault occurrence is explained in the paragraph on Faults ([Fault Mode](#)).

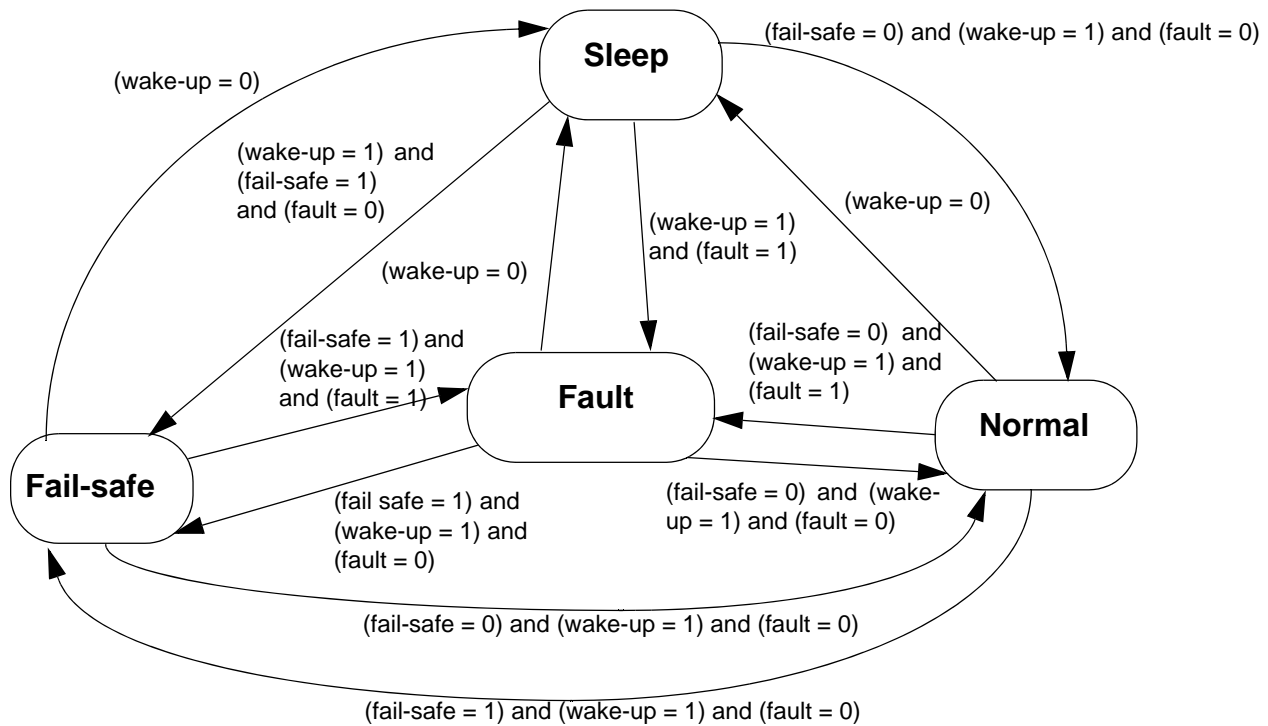

Figure 11. Device Operating Modes

## SLEEP MODE

In Sleep mode, the channels and the SPI interface are turned off to minimize current consumption.

The device enters Sleep mode (wake-up = 0) when both Direct Input pins IN(x) remain Off longer than  $t_{IN}$  sec. (when reset is active; RSTB = 0). This is expressed as follows:

- $V_{PWR}$  (and  $V_{DD}$ ) are within the normal range, and
- wake-up = 0 (wake-up = RSTB or IN\_ON[0] or IN\_ON[1]), and
- fail-safe = X, and
- fault = X

When employed,  $V_{DD}$  must be kept in the normal range. Sleep mode is the default mode after the first application of the supply voltage ( $V_{PWR}$ ), prior to any I/O communication (RSTB and the internal states IN\_ON[0:1] are still at logic [0]). All SPI register contents remain in their default state during Sleep mode.

## FAIL-SAFE MODE

### Entering Fail-safe Mode

Fail-safe mode is entered either upon loss of SPI communication or after loss of optional SPI supply voltage  $V_{DD}$  (**VDD Out of Range**). The FSOB pin will go low and the channels are only be controlled by the direct inputs (IN[0:1]). All protective functions remain fully operational. Previously latched faults are delatched and SPI register contents is reset (except bits POR & PARALLEL). The SPI registers can not

be accessed. These conditions are also described by the following expressions:

- $V_{PWR}$  is within the normal voltage range, and
- wake-up = 1, fault = 0, and
- fail-safe = 1 ( $(V_{DD} \text{ Failure and } V_{DD\_FAIL\_en}=1 \text{ before})$  or  $(t(SPI) > t_{WDTO} \text{ and } WD\_dis = 0)$ ).

The second case corresponds to loss of SPI communication, which is detailed in the next section.

### Watchdog on SPI Communication and Fail-safe Mode

When  $V_{DD}$  is present, the SPI watchdog timer is started upon a rising edge on the RSTB pin. Thereafter, the device monitors the state of the first bit (WDIN) of all received SPI words. When the state of this bit is not alternated at least once within a data stream of duration  $t_{WDTO} = 310 \text{ ms typ.}$ , the device considers the SPI communication has been lost and enters Fail-safe mode. This behavior can be disabled by setting the bit WD\_DIS = 1. The value of watchdog timeout is derived from an internal oscillator.

### Returning from Fail-safe to Normal mode

To exit Fail-safe mode and return to normal mode again, first a SPI data word with its WDIN bit = 1 (D15) must be received by the device (regardless the register it is contained in, and regardless of the values of the other bits in this register). Next, a second data word must be received within the timeout period ( $t_{WDTO} = 310 \text{ ms typ.}$ ), to be able to change any SPI register contents. Upon entering Normal

mode, the FSOB pin returns to logic high and previously set faults and SPI registers are reset, except bits POR, PARALLEL and fault bits of latchable faults that had actually been latched.

## FAULT MODE

The device enters Fault mode when any of the following faults occurs in Normal or Fail-safe mode:

- Over-temperature fault, (latchable fault)
- Over-current fault, (latchable fault)
- Severe short-circuit fault, (latchable fault)
- Output shorted to  $V_{PWR}$  in OFF state (default: disabled)
- Open-load fault in OFF state (default: disabled)
- Open-load fault in ON state (default: disabled)
- External clock failure (default: enabled)
- Over-voltage fault (enabled by default)
- Under-voltage fault, (latchable fault)

The Fault Status pin (FSB) asserts a fault occurrence on any channel in real time (active low). Additionally, the assigned fault bit in the STATR\_s or FAULTR\_s register is set to one. Conversely to the FSB pin, a fault bit remains set until the corresponding register is read, even if the fault has disappeared. These bits can be read via the SO pin. Fault occurrence will also result in a turn-off of the incurred channel, except for the following faults: Open-load (On and Off state), External Clock Failure and Output(s) shorted to  $V_{PWR}$ . Under and over-voltage occurrences will cause simultaneous turn-off of both channels. Details on the device's behavior, after the occurrence of one of the above faults can be found in [Protection and Diagnostic Features](#).

Fault mode ([Operation and Operating Modes](#)) is entered when:

- $V_{PWR}$  ( $+V_{DD}$ ) were within the normal voltage range, and
- wake-up = 1, and
- fail-safe = X, and
- fault = 1 (see [Going from Normal to Fail-safe, Fault or Sleep Mode](#))

## Resetting FAULT bits

Registers STATR\_s and FAULTR\_s contain global and channel-specific fault information. Reading the register the fault bit is contained in, will clear it, provided a failure cause disappearance has been detected and the fault wasn't latched.

## Entering Fault Mode from Fail-safe Mode

When a Fault occurs in Fail-safe mode, the device is in Fault/Fail-safe mode. and behaves according to the description of fault mode. However, SPI registers remain reset and can not be accessed. Only the Direct inputs control the channels.

## Returning from Fault Mode to Fail-safe Mode

When disappearance of the fault previously produced in Fail-safe mode has been detected, the device returns to Fail-

safe mode and behaves accordingly. FSB goes high, but the auto-retry counter is not reset. Latched faults are not delatched. SPI registers remain reset.

## LATCHABLE FAULTS

An auto-retry function (see [Auto-retry](#)) controls how the device responds to the so-called latchable faults. Latchable faults are: over-current (OC), severe short-circuit (SC), over-temperature (OT), and under-voltage (UV). If a latchable fault occurs, the channel is turned off, the FSB pin goes low, and the assigned fault bit is set. These bits can not be reset before the next turn-on event is generated by auto-retry. Next, the channel will automatically be turned on at a programmable interval, provided auto-retry was enabled and the channel wasn't latched.

If the failure disappears prior to the expiration of the available number of auto-retries, the FSB pin automatically returns to logic [1], but the fault bit remains set. It can still be reset by reading out the SPI register in which it is contained.

However, the fault actually gets latched if the failure cause hasn't disappeared at the first turn-on event following expiration of the available amount of auto-retries (see [Auto-retry](#)). In that case, the channel gets latched and the FSB pin remains low. The fault bit can only be reset by reading out the associated SPI register, after having performed a delatch sequence ([Fault Delatching](#)).

## Fault Delatching

To delatch a latched channel and be able to turn it on again, a delatch sequence must execute after the disappearance of the failure cause. Delatching will also allow to reset the fault bit of latched faults (see [Resetting FAULT bits](#)). To reset the FSB pin, both channels must be delatched.

Delatching is achieved by either alternating the state of the channels' fault control signal  $fc[x]$  (generating a 1\_0\_1 sequence), or by resetting the auto-retry counter (provided retry is enabled). See [Reset of the Auto-retry Counter](#). Delatching then actually occurs at the rising edge of the turn-on event.

Signal  $fc[x]$  is an internal signal used by the device's internal logic circuitry to control the diagnostic functions. The value of  $fc[x]$  depends on the state of the variables  $IN\_ON[x]$ ,  $DIR\_dis[x]$  and  $ON[x]$  and is expressed as follows:

$$fc[x] = ((IN\_ON[x] \text{ and } DIR\_dis[x] = 0) \text{ or } ON[x] = 1)$$

Alternating the  $fc[x]$  signal (by) is achieved differently according to the way the user controls the device.

- In direct-input controlled mode ( $DIR\_dis\_s = 0$ ), the  $IN[x]$  pin must be set low, remain low for at least  $t_{IN}$  seconds, and set high again (be switched On). This might happen automatically when operating at frequencies,  $f < 4.0$  Hz.
- In SPI-controlled mode, the  $ON\_bit$  state (D8 of the PWMR\_s reg.) must be alternated ('toggled'). No minimum OFF state duration is required in this case.

Performing a delatch sequence anytime during an ongoing auto-retry sequence (before latching) allows turning the channel on unconditionally.



When a Power-ON event occurs (see [Loss of VPWR, Loss of VDD and Power-on-Reset \(POR\)](#)), latched channels are also delatched and faults are reset.

When Fail-safe mode is entered (fault=1, fail-safe becomes 1) during operating in Fault mode (fault=1, failsafe=0), previously latched faults are delatched and SPI register content is reset (except bits POR & PARALLEL). The device is then in a combined Fail-safe/Fault mode.

When the device was already in Fail-safe mode (fault=1, failsafe=1) and (new) faults occurs, the internal auto-retry counter will not be reset and latched channels will not be delatched until a delatching sequence has been performed (see [Protection and Diagnostic Features](#)).

### PROGRAMMABLE PWM MODULE

Each channel has a fully independent PWM module activated by setting PWM\_en\_s. It modulates an internal or external clock signal. Setting Clock\_int\_s = 1 (bit D6 of the OCR\_s register) activates the internal clock, and setting Clock\_int\_s = 0 activates the external clock. The duty cycle can be set in a range from 0 to 100% with 8 bit-resolution ([Table 6](#)) by setting bits D8...D0 of the PWMR\_s register ([Table 11](#)). The channel's switching frequency equals the clock frequency divided by 256 in internal clock mode, and by 256 or 512 in external clock mode.

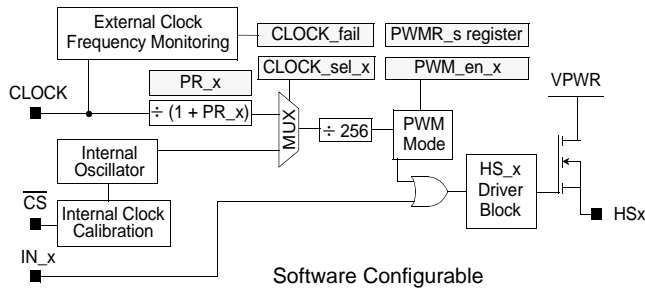

Figure 12. Internal and External Clock Operation

Table 6. PWM Duty Cycle Value Assignment

ON-bit	Duty Cycle	Channel Configuration
0	X	OFF
1	00000000	PWM (1/256 duty cycle)
1	00000001	PWM (2/256 duty cycle)
1	00000010	PWM (3/256 duty cycle)
1	n	PWM ((n+1)/256 duty cycle)
1	11111111	fully ON

By delaying the activation of one channel relative to the other ([Table 7](#)), switch-on surges can be delayed, which may improve EMC performance. Switch-On delay can be selected among seven different values (default=0) by setting bits D2...D0 of the CONFR\_s register (expressed as a number of ext./int. PWM clock periods). To start the PWM function at a

known point in time, the PWM\_en\_s bit (D8 /D7 of the GCR reg.) must only be set to 1 after having set the PWMR\_s (duty cycle) and CONFR\_s (delay) registers. The best way to optimize EMC is to use an external clock with a staggered switch on delay.

Table 7. Switch-on Delay in PWM Mode

Delay Bits	Switch-On Delay
000	no delay
001	32 PWM clock periods
010	64 PWM clock periods
011	96 PWM clock periods
100	128 PWM clock periods
101	160 PWM clock periods
110	192 PWM clock periods
111	224 PWM clock periods

#### External Clock & Internal PWM (CLOCK\_int\_s = 0)

The channels can be controlled by an external clock signal by setting bit D6 = 0 of the OCR\_s register (Clock\_int\_s). Duty cycle values specified in [Table 6](#) apply. When an external clock is used, the value of frequency division (256 when PR[x] = 0) may be doubled by setting the prescaler bit PR[x] = 1 (bit D7 of the OCR\_s reg.). This allows driving the channels at different switching frequencies from a single clock signal. Simultaneously setting PWM\_en\_1=1 and PWM\_en\_0=1 will synchronize the channels.

The clock frequency on the CLOCK pin is monitored when external clock (CLOCK\_int\_s = 0) and pulse width modulation (PWM\_en\_s = 1) are both selected. If a clock failure occurs under these conditions ( $f < f_{CLOCK(LOW)}$  or  $f > f_{CLOCK(HIGH)}$ ), the external clock signal will be ignored and a fault is detected (FSB = 0, CLOCK\_fail bit is set (OD2 in the DIAGR register)). The state of the ON\_s bit in the SPI register then determines the channel's switching state. To return to external clock mode (and reset FSB), the clock-fail bit must be read and the external clock has to be within the authorized range again.

#### Internal Clock & Internal PWM (Clock\_int\_s bit = 1)

By using a reference time slot (usually available from an external microcontroller), the period of each of the internal PWM clocks can be changed or calibrated (see [Programmable PWM module](#)). Calibration of the default period =  $1/f_{PWM(0)}$  reduces its maximum variation from about +/-30 percent to +/- 10%. The programming procedure is activated by sending a dedicated word to the SI-CALR register (see [Table 11](#)). Next, the device sets the new value of the switching period in 2 steps. First it measures the time elapsed between the first falling edge on the CSB pin and the next rising edge on the CSB pin ( $t_{CSB}$ ). Then it changes the value of the internal clock period accordingly. The actual

value of the channel's switching period is obtained by multiplying the internal clock period by 256.

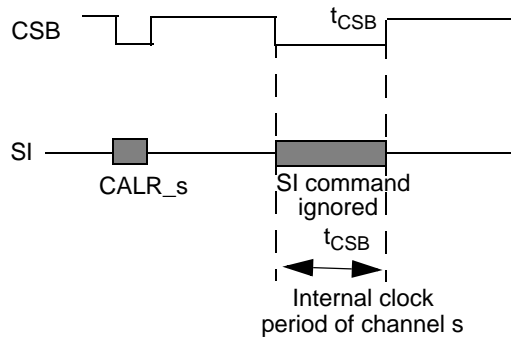

When the duration of the negative CSB pulse is outside a predefined time slot (from  $t_{CSB(MIN)}$  to  $t_{CSB(MAX)}$ ), the calibration event will be ignored and the internal clock frequency will remain unchanged. If the value ( $f_{PWM(0)}$ ) has not been previously calibrated, it will remain at its default level.

### Synchronization of both Channels

When internal clock signals are used to drive the PWM modules, perfect synchronization over a long time can not be achieved, since both clock signals are independent. However, when the channels are driven from the external clock, perfect synchronization can be achieved by simultaneously setting  $PWM\_en\_1=1$  and  $PWM\_en\_0=1$ . The best way to optimize EMC is to use an external clock with a staggered switch on delay (see Table 7).

## PARALLEL OPERATION

The channels can be paralleled to drive higher currents. Setting the PARALLEL bit in the GCR register to logic [1] is mandatory in this case. The improved synchronization of both transistors will allow an equal current distribution between both channels. In parallel mode, both output pins (HS[x]) must be connected, as well as both IN[x] pins, in case of external control. CONF0 and CONF1 must be set to equal values.

### 1- Device Configuration in Parallel mode:

There are two ways to configure the On/Off control: SPI control and Direct Input Control.

- *SPI controlled Parallel mode:*

The switching configuration is solely defined by the (SI) PWMR\_0, CONFR\_0, OCR\_0, and RETRY\_0 registers. As soon as PARALLEL=1, the contents of the corresponding registers in bank 1 will be replaced by that of bank 0, except bits D6-D8 of the CONFR\_1 register (configuration Open-

load/Output short-circuited diagnostics). It is recommended to disable the off-state open-load for the HS1 output. After setting PARALLEL=1, contents of SO registers in bank 0 are copied to the registers of bank 1 only when new information is written in them. Bits OD3, OD4 and OD5 of both FAULTR\_s registers are always reported independently.

- *Direct Input mode:*

The IN0 and IN1 pins must be connected externally.

### 2- Diagnostics in Parallel Mode:

The Diagnostics in Parallel mode operate as follows:

- Open-load in OFF state and - Open-load in ON state:

The OL\_ON and OL\_OFF bits of both FAULTR registers will independently report failures of the channels according to the settings of bits D7 and D6 of the CONFR\_s register.

- Current sensing:

Refer to the Table 22 for a description of the various current sensing modes.

Only the Current sense ratio of bank 0 (D5 of the OCR\_0 register) is considered. The corresponding bit in the OCR\_1 register is copied from that of the OCR\_0 register.

- Output shorted to battery:

The OS-bit (OD3) of each of both FAULT registers will independently report this fault, according to the settings of bit D8 of the CONFR\_s reg.

### 3- Protections in Parallel Mode:

- Over-current:

-Only the Configuration of over-current thresholds & blanking windows of channel 0 are considered.

-In case over-current (OC) occurs on any channel, both channels are turned-off. Regardless the order of occurrence of OC, both OC-bits (OD0) in the FAULT registers are simultaneously set to logic 1.

- Severe short-circuit:

In case of SC detection on any channel, both channels are turned-off and the SC bits (OD1) in both FAULT registers are simultaneously set to logic 1.

- Over-temperature:

In case of OT detection on any channel, both channels are turned-off and both OT bits in the FAULT registers (OD2) are simultaneously set to logic 1.

- auto-retry:

Only one 4-bit auto-retry counter specifies the number of successive turn-on events on paralleled channels (RETRYR\_0). The counter value in register RETRYR\_1 (OD4...OD7) is copied from that in RETRYR\_0.

To delatch the channels, only channel 0 needs to be delatched.

## PROTECTION AND DIAGNOSTIC FEATURES

### PROTECTIVE FUNCTIONS

#### Over-temperature Fault (latchable fault)

The channels have individual over-temperature detection. As soon as a channel's junction temperature rises above  $T_{SD}$  (175 °C typ.), it is turned OFF, the over-temperature bit (OT = OD2) is set, and FSB = 0. FSB can only be reset by turning ON the channel when the junction temperature of both channels has dropped below the threshold:  $T_J < T_{SD}$ . Over-temperature is detected in ON and in OFF state:

- If the channel is ON, the associated output will be switched OFF, the OT bit is set, and FSB = 0.
- If the channel is OFF: FSB will go to logic [0] and remain low until the temperature of both channels is below  $T_{SD}$  and any of the channels are turned on again.

The auto-retry function (if activated) will automatically turn on the channel when the junction temperature has dropped below  $T_{SD}$ . The OT fault bit can only be reset by reading out the FAULTR register, provided that  $T_J < T_{SD}$  and FSB = 1 again.

#### Over-current Fault (latchable fault)

When over-current (OC) is detected, the channel is immediately turned Off (after  $t_{FAULT}$  seconds). The OC-bit is set to 1 and FSB becomes low [0]. Over-current is detected anytime the load current crosses an over-current threshold or exceeds the window width of the selected over-current protection profile. This profile is a stair function with windows the height and width of which are preselected through the SPI port. The maximum allowable value of the load current at a particular moment in time is defined by levels  $I_{OCH}$  and  $I_{OCM}$  and windows  $t_{OCM_x}$  and  $t_{OCH}$  (programmable by SPI bits). The steady-state over-current protection level  $I_{OCL}$  is defined by the settings of the OCL and HOCL bits. Anytime an over-current window is active, current sensing is blanked, and SYNC becomes 1.

#### Over-current Duration Counter

The load current can spend only a defined amount of time in a particular window of the over-current profile. If the time in the window exceeds the selected window width ( $t_{OCx}$ ) or the over-current threshold is crossed, the channel is turned off (OC fault), followed by auto-retry, if enabled. An internal over-current duration counter is employed for this function.

#### Over-current Detection on Resistive and Inductive Loads

According to the load type (resistive or inductive), one of two different over-current profiles should be selected. This is done by connecting a resistor with the appropriate value between the CONF0 (or CONF1) pin and GND (Table 8).

Table 8. Over-current Profile Selection

CONF[0:1] Resistor/Voltage	Type of Load
$R(CONF[x]) < 10 \text{ k}\Omega$ or $0 < V(CONF[X]) < V_{IL} (0.8.0 \text{ V})$	resistive: CONF = 0, Lighting mode
$R(CONF[x]) > 50 \text{ k}\Omega$ or $V_{IH} (2.0 \text{ V}) < V(CONF) < 5.0 \text{ V}$	inductive: CONF = 1, DC motor mode

When over-current windows are active, current sensing is disabled and the SYNCB pin remains high. This is illustrated by Figure 13. After turn on, the output voltage (second waveform (20 V/div.)) and the output current (first waveform, 12 A/div.) rise immediately, but the current sense voltage (third waveform, 2.0 V/div, 1.0 V = 3.0 A) and its synchronization signal SYNC (fourth waveform, 5.0 V/div.) only become active at the end of the selected over-current window (duration  $t_{OCM2\_L}$ ).

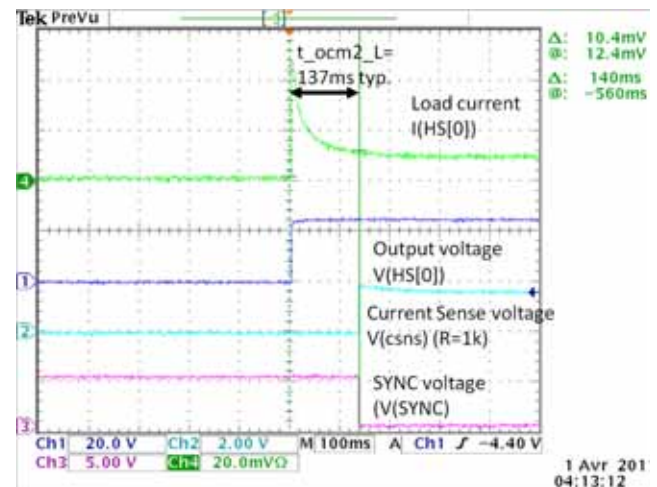

Figure 13. Current Sense Blanking During Over-current Window Activity

Activation of the lighting profile is time driven and activation of the DC motor profile is event driven, as explained by the following.

In lighting mode, the height of the over-current profile is defined by three different thresholds ( $I_{OCH}$ ,  $I_{OCM}$  and  $I_{OCL}$ , which stands for the higher, the middle, and the lower over-current threshold), as illustrated by Figure 5. This profile has two adjacent windows the width of which is compatible with typical bulb inrush current profiles. The width of the first of these windows is either  $t_{OCH1}$  or  $t_{OCH2}$ . The width of the second windows is either  $t_{OCM1\_L}$  or  $t_{OCM2\_L}$  (see Table 17). The lighting profile is activated at each turn-on event including auto-retry, except in switch mode. In switch mode, the profile is activated only at the first turn-on event, but is not renewed. During the on-period, the load current is continuously compared to the programmed over-current



profile. The channel is switched Off when a threshold is crossed or a window width is exceeded.

In DC motor mode, only one over-current window exists, defined by two different current levels, as illustrated by Figure 6. This window is opened anytime the output current exceeds the selected lower over-current level ( $I_{OCLx}$ ). In this case, the allowed over-current duration is defined by parameters  $t_{OCM1\_M}$ ,  $t_{OCM1}$ , and  $t_{OCH2}$ .

The selection of the different profiles and values is explained in the section Address A0100— Over-current protection configuration Register (OCR\_s).

#### Auto-retry After Over-current Shut Off

When `_auto-retry` is activated, OC-latching (Over-temperature Fault (latchable fault)) only occurs after expiration of the available amount of auto-retries (described in Auto-retry).

#### Switch Mode Operation and Over-current Duration

Switch mode is defined as any device operation with a duty cycle lower than 100% at a frequency above  $f_{PWM\_EXT}$  (min.) or  $f_{PWM\_INT}$  (min.). The device may operate in Switch mode in internal/external PWM or in direct input mode. In switch mode, the accumulated time spent by the load current in a particular window segment during On-times of successive switching periods is identified by the aforementioned duration counter, and compared to the active segment width. The associated off-times are excluded by the duration counter. The channel is turned-off when the value of the counter exceeds the window width. In Figure 14, over-current detection shutdown is shown in case of switch mode operation with a duty cycle of 50% (solid line) and 100% (fully-on, dashed line). The device is turned off much later in switch mode than in fully-on mode, since the duration counter only counts over-current during on-times.

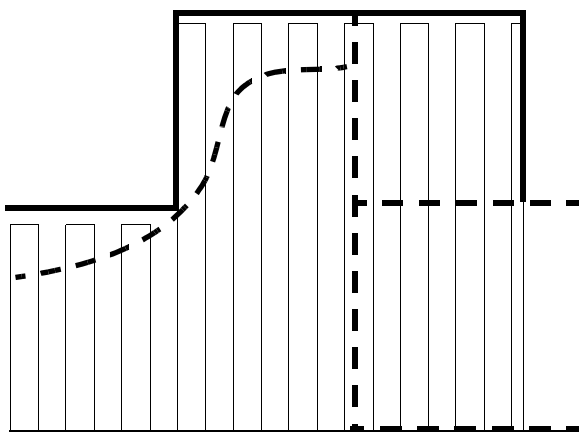

Figure 14. Over-current Shutdown in PWM Mode (solid line) and Non-PWM Mode (dashed line)

#### Reset of the Duration Counter

Reset of the duration counter is achieved by performing a delatch sequence (Fault Delatching). In lighting mode ( $CONF_s = 0$ ), this counter is also reset automatically at each auto-retry (but not in DC motor mode).

In DC motor mode, the duration counter is reset either by performing a delatch sequence or (automatically) after occurrence of a new on-period without any over-current ( $[hson[x]=1]$ ). Reset then actually occurs at the first turn-off instant following that on-period.

In switch mode, the duration counter is not reset by normal PWM activity unless delatching is performed.

#### Severe Short-circuit Fault (latchable fault)

When a severe short-circuit (SC) is detected at turn-ON (wiring length  $L_{LOAD} < L_{SHORT}$ , Table 3), the channel is shut Off immediately. For wiring lengths above  $L_{SHORT}$ , the device is protected from short-circuits by the normal over-current protection functions (Over-current Fault (latchable fault)). When an SC occurs, FSB goes low (logic [0]), and the SC bit is set, eventually followed by an auto-retry. SC is of the latchable type (see Protection and Diagnostic Features and Fault Delatching).

#### Over-voltage Detection (enabled by default)

By default, the supply over-voltage protection ( $V_{PWR}$ ) is enabled (see When over-voltage occurs ( $V_{PWR} \geq V_{PWR(OV)}$ ), the device will turn OFF both channels simultaneously, the FSB pin is asserted low, and the OV fault bit is set to logic [1]. The channels remain OFF until the supply voltage drops below a threshold voltage  $V_{PWR} \leq V_{PWR(OV)} - V_{PWR(OVHYS)}$ . The OV bit can then be reset by reading out the STATR register.

The over-voltage protection can be disabled by setting the `OV_dis = 1` in the general configuration (GCR) register. In this case, the FSB pin will neither assert a fault occurrence, nor will the channels be turned off. However, the fault register (OV bit) will still report an over-voltage occurrence (when  $V_{PWR} \geq V_{PWR(OV)}$ ) as a warning. When  $V_{PWR} \geq V_{PWR(OV)}$ , the value of the on-resistance on both channels ( $R_{DS(ON)}$ ) still lays within the ranges specified in Table 3.

#### Under-voltage Fault (Latchable Fault)

The channels will always be turned off when the supply voltage ( $V_{PWR}$ ) drops below  $V_{PWR(UV)}$ . FSB drops to logic [0], and the fault register's (common) UV bit is set to [1].

When the under-voltage condition then disappears, two different cases exist:

- If the channel's internal control signal `hson[x]` is off, FSB will return to logic [1], but the UV bit will remain set until at least one output is turned on (warning).
- If the channel's control signal is on, the channel will only be turned on if a delatch or POR sequence is performed prior to the turn on request. The UV bit can then only be reset by reading out the STATR register.

Auto-retry (if enabled) will start as soon as the UV condition disappears.

### Extended Mode Protection

In extended mode ( $6.0\text{ V} < V_{PWR} < 8.0\text{ V}$  or  $36\text{ V} < V_{PWR} < 58\text{ V}$ ), the channels are still fault protected, but compliance with the specified protection levels is not guaranteed. The register settings however (including previously detected faults) remain unaltered, provided  $V_{DD}$  is within the authorized range. Below  $6.0\text{ V}$ , the channels are only protected from over-temperature, and this fault will only be reported in the SPI register at the moment  $V_{PWR}$  has again risen above  $V_{PWR(UV)}$ . To allow the outputs to remain ON between  $36\text{ V}$  and  $58\text{ V}$ , over-voltage detection should be disabled by setting  $OV\_dis = 1$  in the GCR reg.).

Faults (over-temperature, over-current, severe short-circuit, over and under-voltage) are reset if:

- $V_{DD} \leq V_{DD(FAIL)}$  with  $V_{PWR}$  in the normal voltage rang
- $V_{DD}$  and  $V_{PWR}$  are below the  $V_{SUPPLY(POR)}$  voltage threshold
- The corresponding SPI register is read after the disappearance of the failure cause (and delatching)

### Drain/source Over-voltage protection

The device will try to limit the Drain-to-Source voltage by turning on the channel whenever  $V_{DS}$  exceeds  $V_{DS(CLAMP)}$ . When a fault occurs (SC, OC, OT, and UV), the device is rapidly switched Off (in  $t < t_{FAULT}$  s), regardless the value of the selected slew rate. This may induce voltage surges on  $V_{PWR}$  and/or the output pin (HS[x]), when connected to an inductive line/load. Turning on the device also dissipates the energy stored in the inductive supply line. This function monitors over-voltage for  $V_{PWR} > 30\text{ V}$ . Below  $V_{PWR} < 30\text{ V}$ , the negative output voltage protection will protect the device from over-voltage by turning on the channel. The feature remains functional after device ground loss.

### Supply Over-voltage Protection

In order to protect the device from excessive voltages on the supply lines, the voltage between the device's supply pins ( $V_{PWR}$  and the GND) is monitored. When the  $V_{PWR}$ -to-GND voltage exceeds the threshold  $V_{D\_GND(CLAMP)}$ , the channel is automatically turned on. The feature is not operational in cases of ground loss.

### Negative Output Voltage Protection

The device will try to limit the under-voltage on the output pins HS[x] when turning off inductive loads. When the output voltage drops below  $V_{CL}$ , the channel is switched on automatically. This feature is not guaranteed after a device ground loss.

The energy dissipation capabilities of the circuit are defined by the  $E_{CL[0:1]}$  parameters. For inductive loads larger than  $20\text{ }\mu\text{H}$ , it is recommended to employ a freewheeling diode. The three different over-voltage protection circuits are symbolically represented in Figure 15. The values of the

clamping diodes are those specified in Table 3. Coupling factor  $k$  represents the current ratio between the current in the supply voltage measurement diode (zener) and that injected into the MOSFET's gate to turn it on.

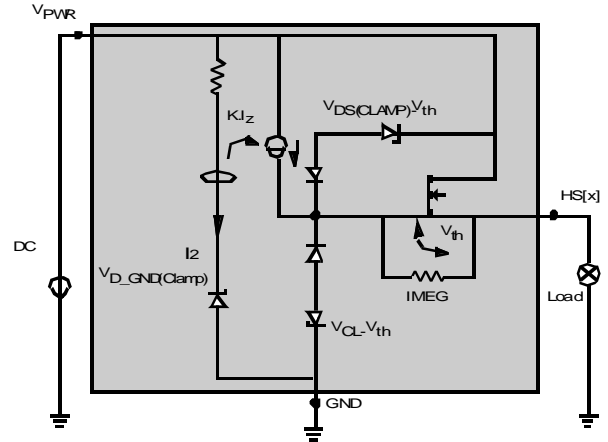

Figure 15. Supply and Output Voltage Protections

### Reverse Voltage Protection on $V_{PWR}$

The device can withstand reverse supply voltages on  $V_{PWR}$  down to  $-28\text{ V}$ . Under these conditions, the outputs are automatically turned ON and the channel's ON resistance ( $R_{DS(ON)}$ ) is similar to that during regular supply voltages. No additional components are required to protect the  $V_{PWR}$  circuit except series resistors ( $>8.0\text{ k}$ ) between the direct inputs IN[0:1] and  $V_{PWR}$  in case they are connected to  $V_{PWR}$ . The  $V_{DD}$  pin needs reverse voltage protection from an externally connected diode (Figure 21).

### Load and system Ground Loss

In case of load ground loss, the channel's state will not change, but the device will detect an Open-load fault. In case of a system GND loss, the channels will be turned off.

### Device Ground Loss

In the (improbable) case where the device loses all of its three ground connections (pins 14, 17, and 22), the channels' state (On/ Off), will depend on several factors: the values of the series resistors connected to the device pins, the voltage of the direct input signals, the device's momentary current consumption (influenced by the SPI settings), and the state of other high side switches on the board, when there are pins in common like FSB, FSOB and SYNC. In the following description, all voltages are referenced to the system (module) GND.

When series resistors are used, the channel state can be controlled by entering Fail-safe mode. The channels will be turned off automatically when the voltage applied to the IN[x] input(s) through the series resistor(s) is not higher than  $V_{DD}$  and be turned on when the IN[x] input(s) are tied to  $V_{PWR}$ . Fail-Safe will be entered under the following conditions:

- all unused pins are tied to the overall system GND connection by resistors > 8.0 k.
- any device pin connected to external system components has a series resistors > 8.0 k (except pins VPWR, VDD, HS[0], HS[1] and R(CSNS)>2.0 k)
- FSB, FSOB, and SYNC pins are in the logic high state when they are shared with other devices. This means none of the other devices are in Fault- or Fail-safe mode, nor should current sensing be performed on any one of them when GND is lost

When no series resistors are employed, the channel state after GND loss will be determined by the voltage on pins IN[0:1] and the voltage shift of the device GND. Device GND shift is determined by the lowest value of the external voltage applied to either pin of the following list: CLOCK, FSB, IN[0:1], FSOB, SCLK, CS, SI, SO, RSTB, CONF[0:1], SYNC, and CSNS. When the device GND voltage becomes a logic low ( $V(\text{GND}) < V_{IL}$ ), the SPI port will continue to operate and the device will operate normally. When the GND voltage becomes logic high ( $V(\text{GND}) > V_{IH}$ ), SPI communication will be lost and Fail-safe mode will be entered. When the voltage applied to the IN[0:1] input is  $V_{PWR}$ , the channel will be turned on: when it is  $V_{DD}$ , the channel will be turned off if  $(V_{DD} - V(\text{GND})) < V_{IH}$ .

## SUPPLY VOLTAGES OUT OF RANGE

### V<sub>DD</sub> Out of Range

If the external  $V_{DD}$  supply voltage is lost (or falls outside the authorized range:  $V_{DD} < V_{DD(\text{FAIL})}$ ), the device enters Fail-safe mode, provided the  $V_{DD\_FAIL\_en}$  bit had been set. Consequently, the contents of all SPI registers are reset. The channels will then be controlled by the direct inputs IN[0:1] (if  $V_{PWR}$  is within the normal range). Since the VPWR pin supplies the circuitry of the SPI, current sense and of most of the protective functions (over-temperature, over-current, severe short-circuit, short to  $V_{PWR}$ , and open-load detection circuitry), these faults are still detected and reported at the FSB pin. However, without  $V_{DD}$ , the SO pin is no longer functional. The SPI registers can no longer be read and detailed fault information is unavailable. Current sensing also becomes unavailable. If  $V_{DD\_FAIL\_EN}$  wasn't set before  $V_{DD}$

was lost, the device remains SPI-controlled, even though the SPI registers can't be read. No current will flow from the VPWR to the VDD pin.

Occurrence of an OLON, OLOFF or OS fault will set the associated bit in the FAULTR\_s register but will not trigger automatic turn-off. Any of these diagnostic functions can be disabled by setting  $OLON\_dis\_s=1$ ,  $OLOFF\_dis\_s=1$ , or  $OS\_dis\_s=1$  (bits D8...D6 of the CONFR reg.).

The functions are guaranteed over the specified ranges for output capacitor values up to 22 nF (+/-20%).

### V<sub>PWR</sub> Supply Voltage Out of Range

In case  $V_{PWR}$  is below the under-voltage threshold  $V_{PWR(UV)}$ , it is still possible to address the device by the SPI port, provided  $V_{DD}$  is within the normal range. It will therefore not prevent other devices from operating when a device is part of a daisy-chain. To accomplish this, RSTB must be kept at logic [1]. When the device operates at supply voltages above the maximum supply voltage ( $V_{PWR}=36\text{ V}$ ), SPI communication is not affected (see [Over-voltage Detection \(enabled by default\)](#)). The internal pull-up and pull-down current sources on the SPI pins are not operational. Executing a Power-on-Reset (POR) sequence is recommended when  $V_{PWR}$  re-enters its authorized range. No current will flow from the VDD to the VPWR pin.

### Loss of V<sub>PWR</sub>, Loss of V<sub>DD</sub> and Power-on-Reset (POR)

In typical applications ([Figure 21](#) and [Figure 22](#)), an external voltage regulator may be used to derive  $V_{DD}$  from  $V_{PWR}$ . In Wake mode, a Power-on-Reset (POR) sequence will be executed and the POR bit (OD6 of the STATR register) will be set if:

- $V_{PWR} > V_{PWR(POR)}$ , after a period  $V_{PWR} < V_{PWR(POR)}$  (and  $V_{DD} < V_{DD(POR)}$  before and after)
- $V_{DD} > V_{DD(POR)}$  after a period with  $V_{DD} < V_{DD(POR)}$  ( $V_{PWR} < V_{PWR(POR)}$  before and after)

POR is also set at the transition to wake-up (by setting  $RSTB = 1$  or  $IN[x]=1$ ) when  $V_{PWR} > V_{PWR(POR)}$  (before and after) or  $V_{DD} > V_{DD(POR)}$  (before and after). POR is not performed when  $V_{PWR} > V_{PWR(POR)}$  after a period  $V_{PWR} < V_{PWR(POR)}$  (and  $V_{DD} > V_{DD(POR)}$  permanently).

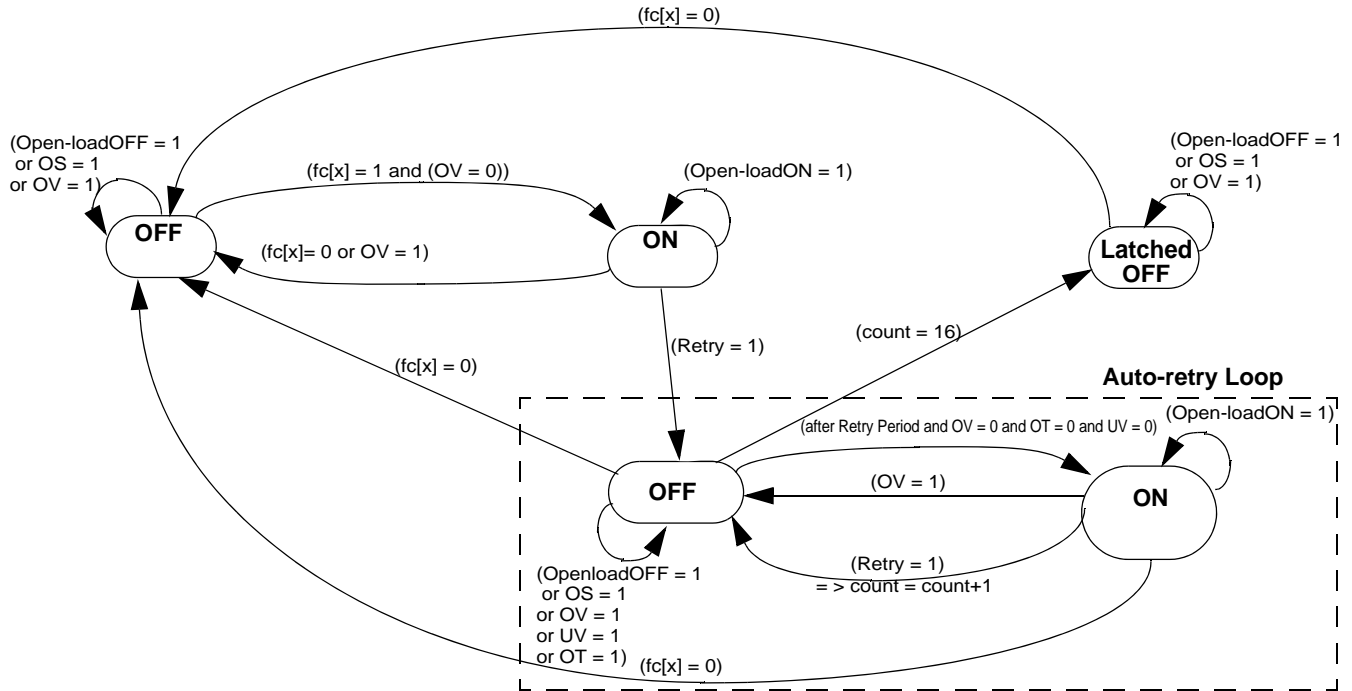

Figure 16. State Machine: Fault Occurrence and Auto-retry

## AUTO-RETRY

The auto-retry circuitry will automatically try to turn on the channel on a cyclic basis. Only faults of the latched type (over-current, severe short-circuit, over-temperature (OT), and under-voltage (UV)) may activate auto-retry. For UV and OT faults, auto-retry will only start after disappearance of the failure cause when auto-retry is enabled. The retry condition is expressed by:

$$\text{Retry}[x] = \text{OC}[x] \text{ or } \text{SC}[x] \text{ or } \text{OT}[x] \text{ or } \text{UV}.$$

If Auto-retry has been enabled, its mode of operation will depend on the settings of the auto-retry related bits (bits D0...D3 of the SI-RETRY\_s register, see Table 22) and the available amount of auto-retries (bits OD7...OD4 of the SO-RETRY\_s reg.). More details can be found in [Number Of Auto-retries](#).

If Auto-retry was disabled, latched faults will immediately be latched upon their occurrence (see [Protection and Diagnostic Features](#)).

### Auto-retry Configuration

To enable the auto-retry function, bit `retry_s` (D0 of the SI-RETRY\_s register) has to be set to the appropriate value. Auto-retry is enabled for `retry_s = 0` when the channel is configured for lighting applications (`CONF=0`). It is enabled for `retry_s=1` for DC motor applications (`CONF[x]=1`).

Table 9. Auto-Retry Activation for Lamps (`CONF=0`) and DC Motors (`CONF=1`)

CONF[x]	Retry_s bit	auto-retry
0	0	enabled
0	1	disabled
1	0	disabled
1	1	enabled

If auto-retry is enabled, an auto-retry sequence will start when the channel's fault control signal is set to 1 (`fc[x] = 1`, [Fault Delatching](#)) and the retry condition applies (`Retry[x]=1`). See [Auto-retry](#).

When a failure occurs (fault = 1), the channel will automatically be switched on again after the auto-retry period. The value of this period ( $t_{\text{AUTO}}$ ) is set through the SPI port bits (D2 and D3 of the REPLY\_s register, see Table 21). When the failure cause disappears before expiration of the available amount of auto-retries, the device will behave normally (`FSB = 1`), but the fault bit remains set until it is cleared. This guarantees a maximum device availability without preventing fault detection.

### Number Of Auto-retries

In case the device was configured for an unlimited amount of auto-retries (`Retry-unlimited_s = 1`), auto-retry will



continue as long as the device remains powered. The channel will never be latched off.

In case a limited amount of retries was selected (Retry-unlimited\_s = 0), auto-retry will continue as long as the value of the 4-bit auto-retry counter does not exceed 15 (bits OD4...OD7 of the RETRY\_s register). After 15 retries, the Rfull bit of the STATR (OD4 for channel 0, OD5 for channel 1) register will be set to a logic high. The amount of available auto-retries is then reduced to one. If the fault still hasn't disappeared at the next retry, the corresponding channel will be switched off definitively and the fault is latched (FSB = 0). See [Protection and Diagnostic Features](#) and [Fault Delatching](#).

Any channel can be turned on at any moment during the auto-retry cycle by performing a delatch sequence. However, this will not reset the retry counter.

The value of the auto-retry counter can be read back in Normal mode (SO-RETRY register bits OD7-OD4).

### Reset of the Auto-retry Counter

The counter of the amount of retries is reset when:

- Fail-safe is entered ([Fail-safe Mode](#))
- Sleep mode is left ([Sleep Mode](#))
- POR occurs ([Supply Voltages Out of Range](#))
- the retry function is set to unlimited (bit Retry-unlimited\_s = 1 (D1 = 1))
- the retry function is disabled (retry\_s bit = D0 of the RETRY\_s register under goes a 1-0 sequence for CONF = 1 and a 0-1 sequence for CONF = 0).

If the channel was latched at the moment the auto-retry counter was reset (case 4), the channel will be delatched, and be turned on after one retry period (if retry was enabled).

### Auto-retry and Over-current Duration

During the on-period following each auto-retry, the load current profile will be compared to the length and height of the selected over-current threshold profile, as described in the section on over-current protection. See [Over-current Fault \(latchable fault\)](#).

When the lighting profile is activated, the over-current duration counter is reset at each auto-retry (to allow sustaining new inrush currents).

For DC motor mode however, it is only reset at the turn-off event of the first PWM period without any over-current (see [Reset of the Duration Counter](#))

[Figure 16](#) gives a description of the retry state machine with the various transitions between operating modes.

## DIAGNOSTIC FEATURES

Diagnostic functions open-load in On state (OLON), open-load in Off state (OLOFF) and output short-circuited to  $V_{PWR}$  (OS) are operational over the frequency and duty cycle ranges specified in [Table 4](#) for PWM mode, but the precise values also depend on the way the device is controlled (direct/internal PWM), on the current sense ratio and on the

optional activation of the open-load in On state detection. As an example, in *direct input* (DIR\_dis\_s = 0), *Low-Current mode* (CSR1), OLON, OLOFF, and OS detection are performed for duty cycle values up to: RPWM\_400\_h = 85% (instead of 90%) when Open-Load in On state detection is enabled (OLON\_dis=0).

### Output Shorted to $V_{PWR}$ Fault

The device will detect short-circuits between the output and  $V_{PWR}$ . The detection is performed during the Off-state. The output-shortened to  $V_{PWR}$  fault-bit (OS\_s) is set whenever the output voltage rises above  $V_{OSD(THRES)}$ . The fault is reported in real time on the FSB pin and saved by the OS\_s bit. Occurrence of this fault will not trigger automatic turn-off.

Even if the short-circuit disappears, the OS\_s bit will not be cleared until the FAULTR register is read. The function may be disabled by setting OS\_dis\_s=1. The function will operate over the duty cycle ranges specified in [Diagnostic Features](#).

This type of event shall be limited to 1000 min. during the vehicle lifetime. In case of permanent output shorted to the battery condition, it is needed to turn-on the corresponding channel.

### Open-load Detection In Off State

Open-load in OFF state detection (OL\_OFF) is performed continuously during each OFF state (both for CSR0 and CSR1). This function is implemented by injecting a small current into the load ( $I_{OLD(OFF)}$ ). When the load is disconnected, the output voltage will rise above  $V_{OLD(THRES)}$ . OL\_OFF is then detected and the OL\_OFF bit in the FAULTR register is set. If disappearance of the open load fault is detected, the FSB output pin will return to a high immediately, but the OL\_OFF bit in the fault register will remain set until it is cleared by a read out of the FAULTR register. The function may be disabled by setting OLOFF\_dis\_s=1. The function will operate over the duty cycle ranges specified in section [Diagnostic Features](#).

### Open-Load Detection In On State (OL\_ON)

Open-Load in ON state detection (OLON) is performed continuously during the On state for CSR0 over the ranges specified in section [Diagnostic Features](#). An Open-load in On state fault is detected when the load current is lower than the Open-load current threshold  $I_{OLD(ON)}$ . This will happen at  $I_{OLD(ON)} = 300$  mA (typ.) for high-current sense mode (CSR0), and at 7.0 mA (typ.) for low-current mode. FSB is asserted low and the OLON bit in the fault register is set to 1, but the channel remains On. FSB will go high as soon as the disappearance of the failure cause is detected, but the OL\_ON bit remains set.

In high current mode (CSR0), Open-Load in On state detection is done continuously during the On state and the OLON-bit remains set even if the fault disappears.

In high current mode, the OLON-bit is cleared when the FAULTR register is read during the Off state, even if the fault hasn't disappeared. The OLON bit is also cleared when the

FAULTR register is read during the ON state, provided the failure cause (load disconnected) has disappeared.

In low current mode (CSR1), OL\_ON is done periodically instead of continuously, and only operates when fast slew rate is selected. When the internal PWM module is used with an internal or external clock (case 1), the period is 150 ms (typ.). When the direct inputs are used (case 2), the period is that of the input signal. The detection instants in both cases are given by the following:

1. In **internal PWM (int./ext. clock), low current mode (CSR1)**, Open-load in ON state detection is not performed each switching period, but at a fixed frequency of about 7.0 Hz (each  $t_{OLLED} = 150$  ms typ.). The function is available for a duty cycle of 100%. OLON detection is also performed at 7.0 Hz, at the first turn-off event occurring 150 ms after the previous OL\_ON detection event (before OS and OL\_OFF).
2. In **direct input, low current mode (CSR1)**, OL\_ON is performed each switching period (at the turn-off instant) but the duty cycle is restricted to the values. Consequently, when the signal on the IN[x] pin has a duty cycle of 100%, OL\_ON will not be performed. To solve this problem, either the internal PWM function must be activated with a duty cycle of 100%, or the channel's direct input must be disabled by setting Dir\_dis\_s=1 (bit D5 of the CONFR-s register). The OLON-bit is only reset when the FAULTR register is read after occurrence of an OL\_ON detection event without fault presence.

### Open-load Detection in Discontinuous Conduction Mode

If small inductive loads (solenoids / DC motors) are driven at lower frequencies, discontinuous conduction mode may occur. Undesired Open-load in On state errors may then be detected, as the inductor current needs some time to rise above the open-load detection threshold after turn-on. This problem can be solved by increasing the switching frequency, or by disabling the function and activating Open-Load in Off state detection instead.

When small DC motors are driven in discontinuous conduction mode, undesired Open-Load in Off state detection may also occur when the load current reaches 0 A during the Off state. This problem can be solved by increasing the switching frequency, or by enabling Open-load in the Off state detection only during a limited time, preferably directly after turn-off (see [Diagnostic Features](#)). The signal on the SYNC pin can be used to identify the turn-off instant.

### CURRENT & TEMPERATURE SENSING

The scaled values of either of the output currents or the temperature of the device's GND pin (#14) can be made available at the CSNS pin. To monitor the current of a particular channel or the general device temperature, the CSNS0\_en and CSNS1\_en bits (see [Table 22](#)) in the general configuration register (GCR) must be set to the appropriate values. When over-current windows are active, current sensing is disabled and the SYNCB pin remains high.

### Instantaneous and Sampled Current Sensing

The device offers two possibilities for load current sensing: instantaneous (synchronous) sensing mode and track & hold mode (see [Figure 8](#)). In synchronous mode, the load current is mirrored through the current sense pin ([Output Current Monitoring \(CSNS\)](#)) and is therefore synchronous with it. After turn-off, the current sense pin does not output the channel current. In track & hold mode however, the current sense pin continues to mirror the load current as it was just before turn-off. Synchronous mode is activated by setting the T\_H\_en bit to 0, and Track & Hold mode by setting the T\_H\_en bit to 1.

### Current Sense Ratio Selection

The load current is mirrored through the CSNS pin with a sense ratio ([Figure 17](#)) selected by the CSNS\_ratio bit in the OCR register. To achieve optimal accuracy at low current levels, the lower current sensing ratio, called CSR1, can be selected. In that case, the over-current threshold levels are decreased. The best accuracy that can be obtained for both ratios is shown in [Figure 18](#). The amount of current the CSNS pin can sink is limited to  $I_{CSNS,MAX}$ . The CSNS pin must be connected to a pull-down resistor ( $470 \Omega < R(CSNS) < 10 \text{ k}\Omega$ , 1.0 k $\Omega$  typical), in order to generate a voltage output. A small low-pass filter can be used for filtering out switching transients ([Figure 21](#)). Current sensing will operate for load currents up to the lower over-current threshold (OCLx A).

### Synchronous Current Sensing Mode

For activation of synchronous mode, T\_H\_en must be set to 0 (default). After turn-on, the CSNS output current will accurately reflect the value of the channel's load current after the required settling time. From this moment on (CSNS valid), the SYNC pin will go low and remain low until a switch off signal (internal/external) is received. This allows synchronization of the device's current sensing feature with an external process running on a separate device (see [Current Sense Synchronization \(SYNC\)](#)). After turn-off, the load current will not flow through the switch, and the load current cannot be monitored.

### Track & Hold Current Sensing Mode

In Track & Hold mode (T&H) (T\_H\_en = 1), conversely from synchronous mode, the CSNS output current is available even after having switched off the load. This feature is useful when the device operates autonomously (internal clock/PWM), since it allows current monitoring without any synchronization of the device. An external sample and hold (S/H) capacitor is not required. After turn on, the CSNS output current reflects the channel's load current with the specified accuracy, after occurrence of the negative edge on the SYNC pin, as in synchronous mode (see [Current Sense Synchronization \(SYNC\)](#)). However, at the switch-off instant, the last observed CSNS current is sampled and its value saved, thanks to an internal S/H capacitor. The SYNC pin will go high (SYNC = 1). If the channel on which Track & Hold current sensing is performed is changed to another, the

internal S/H hold capacitor is first emptied and then charged again to allow current monitoring of the other channel. Consequently, T&H current monitoring of a channel is lost when this channel is in the Off state at the moment the current is monitored on the other channel. Track & Hold mode should not be used for frequencies below 60 Hz.

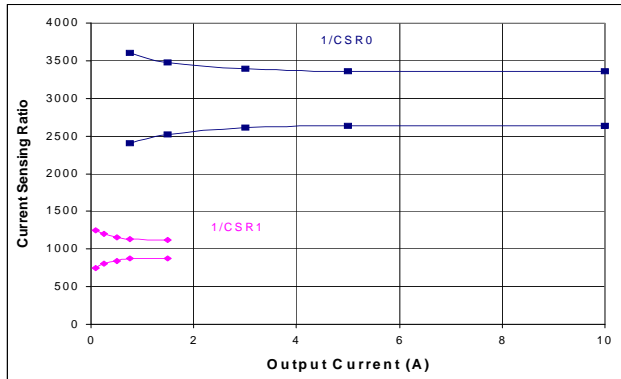

Figure 17. Current Sensing Ratio Versus Output Current

### Current Sense Errors

Current sense accuracy is adversely affected by errors of the internal circuitry's current sense ratio and offset. The value of the current sensing output current can be expressed with sufficient accuracy by the following equation:

$$I_{CSNS} = (I(HS[x]) + I_{LOAD\_ERR\_SYS} + I_{LOAD\_ERR\_RAND}) * CSR_x \quad (1)$$

with  $CSR_0 = (1/3000 + \epsilon_{GAIN0})$  and  $CSR_1 = (1/1000 + \epsilon_{GAIN1})$ .

The device's offset error has a "systematic" and a "random" component ( $I_{LOAD\_ERR\_SYS}$ ,  $I_{LOAD\_ERR\_RAND}$ ). At low current levels, the random offset error may become dominant. The systematic offset error is caused by predictable variations with supply voltage and temperature, and has a small but positive value with small spread. The random offset error is a randomly distributed parameter with an average value of zero, but with high spread. The random offset error is subject to part to part variations and also depends on the values of supply voltage and device temperature. The device has a special feature called offset compensation, allowing an almost complete compensation of the random offset error (see [ESR0\\_ERR](#)). This offset compensation technique greatly minimizes this error. Computing the compensated current sensing value is illustrated in the next sections.

### Activation and Use of Offset Compensation

According to the settings of the OFF\_s bit (in the RETRYR\_s register), opposite values of the random offset error are generated. To compensate the random offset error, two separate measurements with opposite values of the random offset error are required. The measured values must be saved by an external micro-processor. Compensation of the random offset error is achieved by computing the average of both. When a dedicated bit called Offset Positive (OFF = bit D8 of the RETRYR\_s register) is set to 1, the

current sunk through the CSNS pin ( $I_{CSNS}$ ) can be described by:

$$I_{CSNS1} = CSR_x * (I_{LOAD} + I_{LOAD\_ERR\_SYS} + I_{LOAD\_ERR\_RAND}) \quad (2)$$

When bit OFF is set to 0,  $I_{CSNS}$  can be described by:

$$I_{CSNS2} = CSR_x * (I_{LOAD} + I_{LOAD\_ERR\_SYS} - I_{LOAD\_ERR\_RAND}) \quad (3)$$

The random offset term  $I_{LOAD\_ERR\_RAND}$  can be computed from equations (2) and (3) as follows:

$$I_{LOAD\_ERR\_RAND} = (I_{CSNS1} - I_{CSNS2}) / (2 * CSR_x) \quad (4)$$

The compensated current sense value  $I_{CSNS\_COMP}$  can be obtained by computing the average value of measurements  $I_{CSNS1}$  and  $I_{CSNS2}$  as follows:

$$I_{CSNS\_COMP} = (I_{CSNS1} + I_{CSNS2}) / 2 \quad (5)$$

When equations 2 and 3 are substituted in equation 5, the random offset error cancels out, as shows eq. 6:

$$I_{CSNS\_COMP} = (I_{LOAD\_ERR\_SYS} + I_{LOAD}) * CSR_x \quad (6)$$

The systematic offset error  $I_{LOAD\_ERR\_SYS}$  is referenced at the operating point 28 V and 25 °C. It can eventually be fine tuned by performing a calibration. Gain errors at 25 °C (=current sense ratio errors, represented by  $\epsilon_{gain0}$  and  $\epsilon_{gain1}$ ) can also be reduced by performing a calibration at a point in the range of interest. If calibration can not be done, it is recommended to use the typical value of  $I_{LOAD\_ERR\_SYS}$  (see [Systematic offset error \(see Current Sense Errors\)](#)).

### Current Sense Error Model

The figures of uncompensated and compensated current sense accuracy mentioned in [Table 3](#), have been obtained by applying the error model of eq. 7 to the data:

$$I_{CSNS\_MODEL} = (I(HS[x]) + I_{LOAD\_ERR\_SYS}) * CSR_x \quad (7)$$

$$ESR_x\_ERR = (I_{CSNS1} - I_{CSNS\_MODEL}) / I_{CSNS\_MODEL} \quad (8)$$

$$ESR_x\_ERR(COMP) = (I_{CSNS\_COMP} - I_{CSNS\_MODEL}) / I_{CSNS\_MODEL} \quad (9)$$

The computation has been applied to each of the specified measurement points. Model parameters  $I_{LOAD\_ERR\_SYS}$  and  $CSR_x$  have the nominal values, specified on [ESR0\\_ERR](#).

The load current can be computed from this model as:

$$I(HS[x]) = I_{CSNS} / CSR_x - I_{LOAD\_ERR\_SYS} \text{ (uncompensated)} \quad (10)$$

$$I(HS[x]) = I_{CSNS\_Comp} / CSR_x - I_{LOAD\_ERR\_SYS} \text{ (compensated)} \quad (11)$$

### Offset Compensation in Track & Hold Mode

In Track & Hold mode, the last observed sense current ( $I_{CSNS}$ ) is sampled at the switch off instant. This takes into account the currently active settings of the OFF\_s offset compensation bit. Changing the value of the OFF bit during the switch's off time will produce an identical value of the current sense output. Consequently, to implement the before mentioned offset compensation technique, the channel must have been turned on at least once prior to sensing the output current, with an opposite value of the OFF bit.

### System Requirements for Current Monitoring

Current monitoring is usually implemented by reading the (RC-filtered) voltage across the pull-down resistor connected between the CSNS pin and GND (Figure 21). Therefore, measurements (1) and (2) must be spaced sufficiently wide apart (e.g. 5 time constants) to get stabilized values, but close enough to be sure that the offset value wasn't changed. The A/D converter of the external micro-controller that is used to read the current sense voltage  $V(csns)$  must have sufficient resolution to avoid introducing additional errors.

### Accuracy with and without Offset Compensation

The sensing accuracy for CSR0 and CSR1, obtained before and after offset compensation, is shown in Figure 18 (solid lines = Full Scale accuracy with offset compensation and dotted lines without offset compensation).

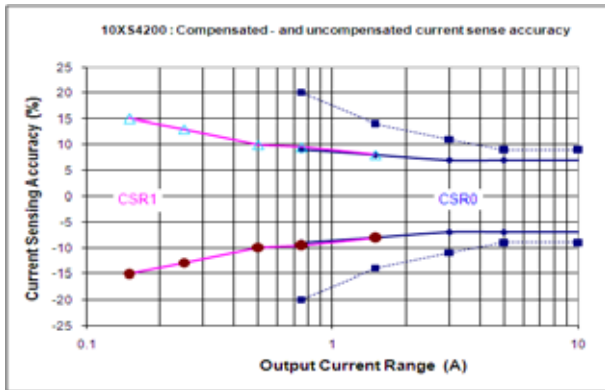

Figure 18. Current Sense Accuracy Versus Output Current

In Track & Hold mode, the accuracy of the current sense function will be lowered according to the values shown in Figure 19 (error percentage as a function of the switch-off time is displayed, for CSR0 and CSR1). Track & Hold mode shouldn't be used below  $f = 60$  Hz.

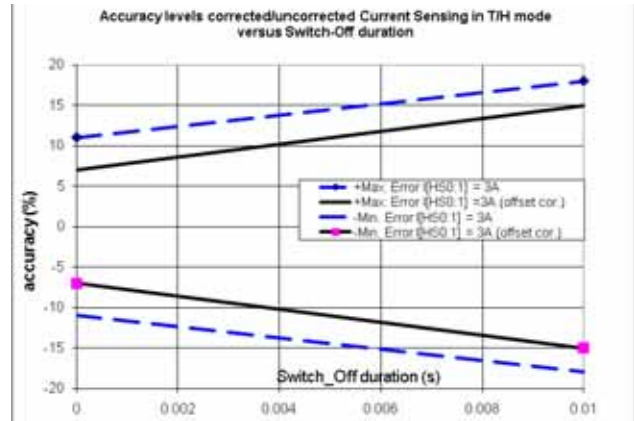

Figure 19. Track and Hold Current Sense Accuracy

### Temperature Prewarning Detection

In Normal mode, the temperature prewarning (OTW) bit is set (FAULTR register), when the observed temperature of the GND pin is higher than  $T_{OTWAR}$  (pin #14, see Figure 3). The feature is useful when the temperature of the direct surroundings of the device must be monitored. However, the channel isn't switched off. To be able to reset the OTW-bit, the FAULTR register must be read after the moment that temperature  $T^{\circ}C < T_{OTWAR}$ .

### Switching State Monitoring

The switching state (On/Off) of the channels is reported in real time by bits  $OUT[x]$  in the STATR register (bit  $OD0/OD1$ ). The  $Out[x]$  bit is asserted logic high when the channel is on. (output voltage  $V(HS[x])$  higher than  $V_{PWR}/2$ ). When supply voltage  $V_{PWR}$  drops below 13 V, the reported channel state may not correspond to the state of the channel's control signal  $hson[x]$ , in case of an open load fault (see Factors Determining the Channel's Switching State).

### EMC PERFORMANCES

Specified EMC performance is board and module dependent, and applies to a typical application (Figure 21). The device withstands transients per ISO 7637-2 /24 V. An external freewheeling diode connected to at least one output is required for sustaining ISO 7637 Pulse 1 (600 V). To withstand Pulse 2, at least one of the 2 channels must be connected to a typical load (bulb). It withstands electric fields up to 200 V/m and bulk current injection (BCI) up to 200 mA per ISO11452. The device meets Class 5 of the CISPR25 emission standard.



## LOGIC COMMANDS AND SPI REGISTERS

### SPI PROTOCOL DESCRIPTION

The SPI interface offers full duplex, synchronous data transfer over four I/O lines: Serial Input (SI), Serial Output (SO), Serial Clock (SCLK), and Chip Select (CSB). The SI/SO pins of the device follow a first-in first-out (D15 to D0) protocol. Transfer of input and output words starts with the most significant bit (MSB). All inputs are compatible with 5.0

or 3.3 V CMOS logic levels. Parity check is performed after transfer of each 16-bit SPI data word. The SPI interface can be driven without series resistors provided that voltage ratings on  $V_{DD}$  and SPI pins (Table 2) aren't exceeded. Unused SPI-pins must be tied to GND, eventually by resistors (see Device Ground Loss).

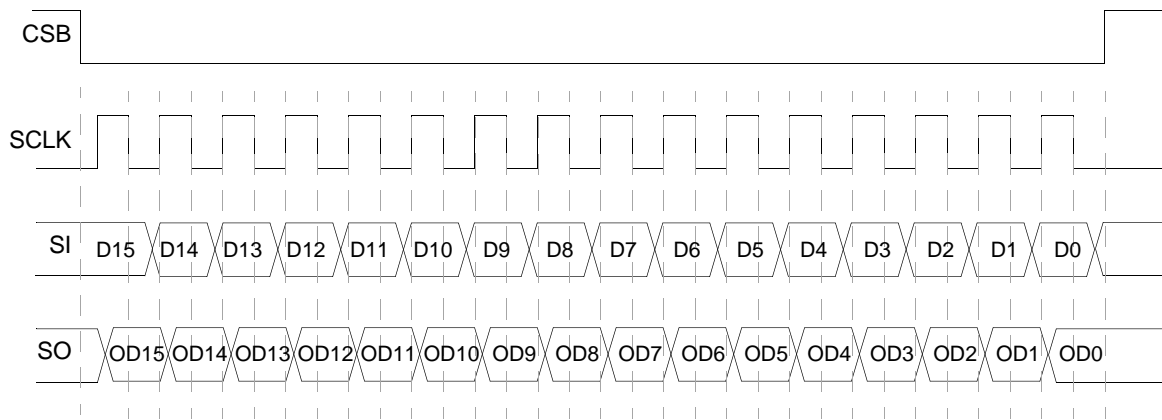

- Notes
1. RSTB must be in a logic [1] state during data transfer.
  2. Data enter the SI pin starting with D15 (MSB) and ending with bit D0.
  3. Data are available on the SO pin starting with bit OD15 (MSB) and ending with bit 0(OD0).

Figure 20. 16-Bit SPI Interface Timing Diagram

### SERIAL INPUT COMMUNICATION PROTOCOL

SPI communication requires that RSTB = high. SPI communication is accomplished with 16-bit messages. A valid message must start with the MSB (D15) and end with the LSB (D0) (Table 21). Incoming messages will be interpreted according to Table 11. The MSB, D15, is the watchdog bit (WDIN). Bit D14, Parity check (P), must be set such that the total number of 1-bits in the SPI word is even (P=0 for an even number of 1-bits and P=1 for an odd number). Bank selection is done by setting bit D13. Bits D12:D10 are used for register addressing. The remaining ten bits, D9:D0, are used to configure the device and activate diagnostic and protective functions. Multiple messages can be transmitted for applications with daisy chaining (or to validate already transmitted data) by keeping the CSB pin at logic 0. Messages with a length different from a multiple of 16 or with a parity error will be ignored. The device has thirteen input registers for device configuration and thirteen output registers containing the fault/device status and settings. Table 11 gives the SI register function assignment. Bit names with extension “\_s” refer to functions that have been implemented independently for each of both channels.

### SERIAL PORT OPERATION

When Chip Select occurs (1-to-0 transition on the CSB pin), the output register data is clocked out of the SO pin

(MSB-first) at the serial clock frequency (SCLK). Bits at the SI pin are clocked in at the same time. The first sixteen SO register bits are those addressed by the previous SI word (bit D13, D2...D0 of the STATR\_s input register). At the end of the chip select event (0-to-1 transition), the SI register contents are latched. The second SPI word clocked out of the Serial Output (SO) after the first CSB event represents the initial SO register contents. This allows daisy chaining and data integrity verification.

The message length is validated at the end of the CSB event (0-to-1 transition). If it is valid (multiples of 16, no parity error), the data is latched into the selected register. After latch-in, the SO pin is tri-stated and the status register is updated with the latest fault status information.

### Daisy Chain Operation

Daisy-chaining propagates commands through devices connected in series. The commands enter the device at the SI pin and leave it by the SO pin, delayed by one command cycle of 16 bits. To address a particular device in a daisy chain, the CSB pin of all the devices in that chain has to be kept low until the SPI message has arrived at its destination. Once the command has been clocked in by the addressed device, it can be executed by setting CSB =1.

**Table 10. SI Message Bit Assignment**

Bit n°	SI Reg. Bit	Bit Functional Description
MSB . . . . LSB	D15	Watchdog in (WDIN): Its state must be alternated at least once within the timeout period
	D14	Parity (P) check. P-bit must be set to 0 for an even number of 1-bits and to 1 for an odd number.
	D13	Selection between SI registers from bank 0 (0= channel 0) and bank 1 (Table 13).
	D12:D10	Register address bits.
	D9:D0	Used to configure the device and the protective functions and to address the SO registers.

**Table 11. Serial Input register Addresses and Function Assignment**

SI Register	SI Data															
	D 15	D 14	D 13	D 12	D 11	D 10	D9	D8	D7	D6	D5	D4	D3	D2	D1	D0
STATR_s	WDIN	P	A <sub>0</sub>	0	0	0	0	0	0	0	0	0	0	SOA2	SOA1	SOA0
PWMR_s	WDIN	P	A <sub>0</sub>	0	0	1	0	ON_s	PWM7_s	PWM6_s	PWM5_s	PWM4_s	PWM3_s	PWM2_s	PWM1_s	PWM0_s
CONFR_s	WDIN	P	A <sub>0</sub>	0	1	0	0	OS_dis_s	OLON_dis_s	Oloff_dis_s	DIR_dis_s	SR1_s	SR0_s	DELAY2_s	DELAY1_s	DELAY0_s
OCR_s	WDIN	P	A <sub>0</sub>	1	0	0	0	HOCR_s	PR_s	Clock_int_s	CSNS_rati_o_s	t <sub>OCH_s</sub>	t <sub>OCM_s</sub>	OCH_s	OCM_s	OCL_s
RETRY_s	WDIN	P	A <sub>0</sub>	1	0	1	0	OFF_s	0	0	0	0	Auto_period_1_s	Auto_period_0_s	Retry_unlimited_s	retry_s
GCR	WDIN	P	0	1	1	0	0	PWM_en_1	PWM_en_0	PARALLEL	T_H_en	WD_dis	V <sub>DD_FAIL_en</sub>	CSNS1_en	CSNS0_en	OV_dis
CALR_s	WDIN	P	A <sub>0</sub>	1	1	1	0	1	0	1	0	1	1	0	1	1
contents after reset*	0	X	0	X	X	X	0	0	0	0**	0	0	0	0	0	0

\* = RSTB = 0 or V<sub>DD</sub>(FAIL) after V<sub>DD</sub> = 5.0 V or POR

\*\* = except bit D6 (PARALLEL) of the GCR register that is saved when V<sub>DD</sub>(FAIL) occurs, provided V<sub>DD</sub> = 5.0 V and V<sub>DD\_FAIL\_EN</sub> = 1 before

X = register address, P = parity bit

**Table 12. Serial Output Register Bit Assignment**

	bits D13, D2, D1, D0 of the Previous STATR				SO Returned Data																
	SOA3	SOA2	SOA1	SOA0	OD15	OD14	OD13	OD12	OD11	OD10	OD9	OD8	OD7	OD6	OD5	OD4	OD3	OD2	OD1	OD0	
STATR	0	0	0	0	WDIN	PF	SOA3	SOA2	SOA1	SOA0	NM	OV	UV	POR	R_FUL_L1	R_FUL_L0	FAULT1	FAULT0	OUT1	OUT0	
FAULTR_s	A <sub>0</sub>	0	0	1	WDIN	PF	SOA3	SOA2	SOA1	SOA0	NM	OTW	0	0	OLON_s	OLOFF_s	OS_s	OT_s	SC_s	OC_s	
PWMR_s	A <sub>0</sub>	0	1	0	WDIN	PF	SOA3	SOA2	SOA1	SOA0	NM	ON_s	PWM7_s	PWM6_s	PWM5_s	PWM4_s	PWM3_s	PWM2_s	PWM1_s	PWM0_s	
CONFR_s	A <sub>0</sub>	0	1	1	WDIN	PF	SOA3	SOA2	SOA1	SOA0	NM	OS_dis_s	OLON_dis_s	OLOFF_dis_s	DIR_dis_s	SR1_s	SR0_s	DELAY2_s	DELAY1_s	DELAY0_s	
OCR_s	A <sub>0</sub>	1	0	0	WDIN	PF	SOA3	SOA2	SOA1	SOA0	NM	HOCR_s	PR_s	Clock_int_s	CSNS_ratio_s	tOCH_s	tOCM_s	OCH_s	OCM_s	OCL_s	
RETRYR_s	A <sub>0</sub>	1	0	1	WDIN	PF	SOA3	SOA2	SOA1	SOA0	NM	OFP	R3	R2	R1	R0	Auto_period1_s	Auto_period0_s	Retry_unlimited_s	retry_s	
GCR	0	1	1	0	WDIN	PF	SOA3	SOA2	SOA1	SOA0	NM	PWM_en_1	PWM_en_0	PARALLEL	T_H_en	WD_dis	VDD_Fail_en	CSNS1_en	CSNS0_en	OV_dis	
DIAGR	0	1	1	1	WDIN	PF	SOA3	SOA2	SOA1	SOA0	NM	CONF1	CONF0	ID1	ID0	IN1	IN0	CLOCK_fail	CAL_fail1	CAL_fail0	
contents after reset or failure*	N/A	N/A	N/A	N/A	0	0	0	0	0	0	0	0	0	0	0	0	0	0	0	0	0

\* = RSTB = 0 or V<sub>DD</sub>(FAIL) after V<sub>DD</sub> = 5.0 V, or POR

\*\* = except bit D6 (PARALLEL) of the GCR register that is saved when V<sub>DD</sub>(FAIL) occurs provided V<sub>DD</sub> = 5.0 V and VDD\_Fail\_en = 1 before

\*\*\* = except bit D7 (POR) of the STATR register that is saved when V<sub>DD</sub>(FAIL) occurs after V<sub>DD</sub> = 5.0 V and VDD\_Fail\_en = 1 (fail-safe mode)

x = register address, PF = parity Fault

### SI REGISTER ADDRESSING

The address in the title of the following sections (A<sub>0</sub>xxx) refer to bits D[13:10] of the SPI word required to address the associated SI register. Bit A<sub>0</sub> = D13 selects between registers of bank 0 and bank 1 (Table 13). The function assignment of register bits D[8:0] is described in the associated section. The “\_s” behind a register name indicates that the variable applies to the register contents of both banks.

**Table 13. Value of bit A<sub>0</sub> Required for Addressing Register Banks 0 or 1**

Value A <sub>0</sub> (D13)	Bank
0	0 = channel 0 (default)
1	1 = channel 1

### ADDRESS A<sub>0</sub>000—STATUS REGISTER (STATR\_S)

To read back the contents of any of the 13 SO registers, bits D[13:10] of the channel's SI STATR register must be set to A<sub>0</sub>000 and bits D[2:0] in the same SPI word to the address of the desired SO register. The SO registers thus addressed are: STATR, FAULTR\_s, PWMR\_s, CONFR\_s, OCR\_s, RETRYR\_s, GCR, and DIAGR (Table 15).

### ADDRESS A<sub>0</sub>001— PWM CONTROL REGISTER (PWMR\_S)

The PWMR\_s register contents determines the value of the PWM duty cycle at the output (Table 11), both for internal and external clock signals.

Bit D8 must be set to 1 to activate this function. The desired value of duty cycle is obtained by setting Bits D7:D0 to one of the 256 levels as shown in Table 6. To start the

PWM function at a known point in time, the PWM\_en\_s bit (both in the GCR register) must be set to 1.

### ADDRESS A<sub>0</sub>010—CHANNEL CONFIGURATION REGISTER (CONFR\_S)

The CONFR\_s is used to select the appropriate value of slew rate and turn-ON delay. The settings of Bits D[8:6] determine the activation of open-load and short-circuit (to V<sub>PWR</sub>) detection. Bit D13 (= A<sub>0</sub>) of the incoming SPI word determines which of both CONFR registers is addressed (Table 10).

Setting bit D8 (OS\_dis\_s) to logic [1] disables detection of short-circuits between the channel's output pin and the VPWR pin. The default value [0] enables the feature.

Setting bit D7 (OLON\_dis\_s) to logic [1] disables detection of open-load in the On state for the selected channel. The default value [0] enables this feature (Table 14).

Setting bit D6 (OLOFF\_dis\_s) to logic [1] disables detection of open-load in the OFF state. The default value [0] enables the feature, see Table 14.

**Table 14. Selection of Open-load Detection Features**

OLON_dis_s (D7) (in On state)	OLOFF_dis_s (D6) (in Off state)	Selected Open-load Detection function
0	0	both enabled (default)
0	1	Off state detection disabled
1	0	On state detection disabled
1	1	Both disabled

Setting bit D5 (DIR\_DIS\_s) to logic [0] will enable direct control on the selected channel. Setting bit D5 to logic [1] will disable direct control. In that case, the channel state is determined by the settings of the internal PWM functions.

D4:D3 bits (SR1\_s and SR0\_s) control the slew rate at switch On and switch Off (Table 15) take place. The default value ([00]) corresponds to the medium slew rate. Rising and falling edge slew rates are identical.

**Table 15. Slew Rate Selection**

SR1_s (D4)	SR0_s (D3)	Slew Rate
0	0	medium (default)
0	1	low
1	0	high
1	1	medium SR<SR< high SR

Delaying a channel's turn-On instant with respect to the other is accomplished by setting bits D2:D0 of the PWMR\_s register to the appropriate values. Switch On will be delayed by the number of (internal/external) clock periods shown in Table 7. Refer to the section Programmable PWM module.

### ADDRESS A<sub>0</sub>100— OVER-CURRENT PROTECTION CONFIGURATION REGISTER (OCR\_S)

The contents of the OCR\_s registers determines operation of over-current, current sensing, and PWM related functions. For each load type (bulb or DC motor), a different kind of over-current profile exists (see Figure 5). For lighting mode, the over-current profile is defined by three different thresholds called the higher (=I<sub>OCH</sub>), the middle (=I<sub>OCM</sub>) and the lower (=I<sub>OCL</sub>) threshold. The DC motor profile only has two thresholds (I<sub>OCH</sub> and I<sub>OCL</sub>).

Each threshold can have 2 different values, except I<sub>OCL</sub> that can have 3 different values (I<sub>OCL1</sub>, I<sub>OCL2</sub>, I<sub>OCL3</sub>). Setting the low current sense ratio (CSR1) will reduce the values of all the over-current thresholds by a factor of three. The terminology is defined as follows: I<sub>OCxy\_z</sub> stands for over-current threshold x (x=H, M or L) that can have two or three different values, selected by y (y=1, 2, (or 3)). The previously selected current sense ratio (z=0 for CSR0 and z=1 for CSR1) further determines the value of the applicable over-current threshold, see: Over-current Detection thresholds with CSNS\_ratio bit = 0 (CSR0).

Setting bit D8 (HOCR\_s) to 0 activates over-current level I<sub>OCL1</sub>, the highest of the 3 levels, regardless the value of the D0 bit. Setting HOCR to 1 activates the medium level I<sub>OCL2</sub> when D0 = 0, and the lowest level I<sub>OCL3</sub> when D0 = 1 (Table 20). When over-current windows are active, current sensing is not available.

Bit D7 (PR\_s) controls which of two divider values are used to create the PWM frequency from the external clock. Setting bit D7 to 1 causes the external clock to be divided by 512. When PR\_s = 0, the divider is 256.

Setting bit D6 (Clock\_int\_s) activates the internal clock of the selected channel. The default value [0] will configure the PWM module to use an external clock signal.

Setting bit D5 (CSNS\_ratio\_s) to 1 activates the "low-current" current sense ratio CSR1, optimal for measuring currents in the lowest range. The default value [0] activates the "high-current" sensing ratio CSR0 (Table 16).

**Table 16. Current Sense Ratio Selection**

CSNS_ratio_s (D5)	Current Sense Ratio
0	CRS0 (default)
1	CRS1

The width of the over-current protection window(s) is controlled by bits D4 and D3 (t<sub>OCH\_s</sub> and t<sub>OCM\_s</sub>), and also depends on the load type configuration as shown in Table 17. (CONF[x]=0: bulb lamp, CONF[x]=1: DC motor).

The lighting profile has two adjacent windows the width of which is compatible with typical bulb inrush current profiles. The width of the first of these windows is either t<sub>OCH1</sub> or t<sub>OCH2</sub>. The width of the second window is either t<sub>OCM1\_L</sub> or t<sub>OCM2\_L</sub> (see Table 17).

The DC motor profile only has one over-current window defined by only two different thresholds ( $I_{OCH}$  and  $I_{OCL}$ ) as illustrated by Figure 6. In this case, the maximum over-current duration is selected among four values:  $t_{OCM1\_M}$ ,  $t_{OCM2\_M}$ ,  $t_{OCH1}$  and  $t_{OCH2}$ .

**Table 17. Dynamic Over-current Threshold Activation Times for Bulb and DC Motor Profiles**

CONF[x]	$t_{OCH\_s}$ (D4)	$t_{OCM\_s}$ (D3)	Selected threshold activation times
0	0	0	$t_{OCH1}$ and $t_{OCM1\_L}$
0	0	1	$t_{OCH1}$ and $t_{OCM2\_L}$
0	1	0	$t_{OCH2}$ and $t_{OCM1\_L}$
0	1	1	$t_{OCH2}$ and $t_{OCM2\_L}$
1	0	0	$t_{OCM1\_M}$
1	0	1	$t_{OCM2\_M}$
1	1	0	$t_{OCH1}$
1	1	1	$t_{OCH2}$

Bit D2 (OCH\_s) selects the value of the higher (upper) over-current threshold among two values. The default value [0] corresponds to the highest value, and [1] to the lowest value (Table 18).

**Table 18. OCH Upper Current Threshold Selection**

OCH_s (D2)	OCH current threshold
0	OCH1_s (default)
1	OCH2_s

Bit D1 (OCM\_s) sets the value of the middle over-current threshold. The default value [0] corresponds to the highest value, and [1] to the lowest value (Table 19). In DC motor mode, there is no middle over-current threshold and the value of this bit has no influence.

**Table 19. OCM Current Threshold Selection**

OCM_s (D1)	OCM current threshold
0	OCM1_s (default)
1	OCM2_s

Bit D0 (OCL\_s) and D8 (HOCCR) set the value of the lowest over-current threshold accordingly, as shown in Table 20.

**Table 20. OCL Current Threshold Selection**

HOCCR (D8)	OCL_s (bit D0)	Selected OCL current level
0	0	OCL1_x (default)
0	1	OCL1_x
1	0	OCL2_x
1	1	OCL3_x

### ADDRESS A<sub>0</sub>101— AUTO-RETRY REGISTER (RETRYR\_S)

The RETRYR\_s register contents are used to configure the different auto-retry options (Auto-retry) and the offset compensation feature of the current sense function.

Setting bit D8 to 1 (OFP = 1) causes the offset current to be added to the sensed current (CSNS). Setting bit D8 to 0 results in the offset current being subtracted from the sensed current.

Setting D3 and D2 (Table 21) to the appropriate values allows selection of the value of the auto-retry period among four predefined values.

**Table 21. Auto-retry Period**

Auto_period1_s (D3)	Auto_period0_s (D2)	Retry Period
0	0	$t_{AUTO\_00}$ (default)
0	1	$t_{AUTO\_01}$
1	0	$t_{AUTO\_10}$
1	1	$t_{AUTO\_11}$

Setting bit D1 to 1 (RETRY\_unlimited\_s = 1) results in an unlimited number of auto retries, provided the auto-retry function wasn't disabled.

Setting bit D1 to 0 (RETRY\_unlimited\_s = 0) limits the amount of auto retries to 16 (see Number Of Auto-retries). The value of the counter will neither be reset after delatching, nor when the fault disappears.

Setting bit D0 (retry\_s) will enable or disable auto-retry, accordingly to setting of the CONF pin.

For CONF[x] = 0 (Lighting profile configured), setting retry\_s = 1 disables auto-retry. The default value [0] enables it.

For CONF[x] = 1 (DC motor), setting retry\_s = 1 enables auto-retry. The default value [0] disables it.

## ADDRESS 0110—GLOBAL CONFIGURATION REGISTER (GCR)

The GCR register is used to activate various functions and diagnostic functions. See [Table 9](#)

Setting bits D8 = 1 and D7 = 1 of the GCR register (PWM\_en\_1 and PWM\_en\_0) will activate the internal PWM function of both channels simultaneously according to the values of duty cycle and turn-on delays in the PWMR\_s and CONFR\_s registers ([Table 6](#)). However, this option should never be used to drive channels in parallel. To increase the load current capability, the instructions in the section [Parallel Operation](#) should be followed.

Setting bit D6 will set parallel mode (improved switching synchronization between both channels). Only configuration and diagnostic information of bank 0 (A<sub>0</sub> = 0) is available in this setting (see [Parallel Operation](#)).

Setting bit D6 will set parallel mode (improved switching synchronization between both channels). Only configuration and diagnostic information of bank 0 (A<sub>0</sub> = 0) is available in this setting (see [Parallel Operation](#)).

Setting Bit D5 (T\_H\_en = 1) activates Track & Hold current sensing mode. When T&H is activated, the value of the channel's load current is kept available after turn-off.

Setting bit D4 (WD\_dis = 1) disables the SPI watchdog function. A logic [0] enables the SPI watchdog.

Setting bit D3 (V<sub>DD\_FAIL\_EN</sub> = 1) will enable or disable the V<sub>DD</sub> failure detection. When enabled, the device will enter Fail-safe mode after V<sub>DD</sub> < V<sub>DD(FAIL)</sub>.

Bits D6 (parallel bit), D2 and D1 set the different (current) sensing options. The CSNS pin outputs a scaled value of the selected channel's load current, the sum of both currents or the die temperature, according to the values in [Table 22](#). When the highest over-current range is selected (bit D8 of the OCR register, HOCR = 0), the device's CSNS pin will only output scaled values of a single channel's load current.

**Table 22. Current Sense Pin Functionality Selection**

D8	D6	D2	D1	Activated Function at CSNS Pin
x	x	0	0	disabled
0	x	0	1	current sensing on channel 0
0	x	1	0	current sensing on channel 1
0	x	1	1	temperature sensing
1	0	0	1	current sensing on channel 0
1	x	1	0	current sensing on channel 1
1	x	1	1	temperature
1	1	0	1	Sensing of summed currents; channels 0 and 1

Setting bit D0 (OV\_dis = 1 of the GCR reg.) will disable over-voltage protection. Setting this bit to [0] (default), will enable it.

## ADDRESS A<sub>0</sub>111—CALIBRATION REGISTER (CALR\_S)

The internal clock frequency of both channels can be calibrated independently. Setting the appropriate calibration word in the CALR\_s register ([Table 11](#)) puts the device in calibration mode. The default switching frequency is 400 Hz, but can be changed by applying a specific calibration procedure. See [Internal Clock & Internal PWM \(Clock\\_int\\_s bit = 1\)](#).

## SO REGISTER ADDRESSING

The device has two register banks, each of which has five channel-specific SO registers containing the channel's configuration and diagnostics status ([Table 7](#)). These registers are FAULTR\_s, PWMR\_s, CONFR\_s, OCR\_s, and RETRYR\_s.

Global fault and diagnostic information is contained in the following common SO-registers: STATR, GCR, and DIAGR. All the SO registers can be addressed by setting the appropriate bits in the SI-STATR\_s register (bits D13, D2, D1, D0). The value of the bit D13 determines which register bank is addressed (bank 0 or 1). Data is made available the next cycle after register addressing.

The output status register correctly reflects the contents of the addressed SO register as long as CSB is low, except when the data from the previous SPI cycle was invalid. In this case, the device outputs the contents of the last successfully addressed SO register.

## SERIAL OUTPUT REGISTER ASSIGNMENT

The output register that will be shifted out through the SO pin is previously addressed by bits D13, D2, D1, and D0 of the STATR\_s SI register ([Table 11](#)). [Table 22](#) gives the functional assignment (OD15:OD0) of each of the thirteen SO register bits, preceded by the address of the SI STATR\_s required to address it.

- Bit OD15 (MSB) reports the state of the watchdog bit from the previously clocked-in SPI message.
- Bit OD14 (PF, active 1) reports an eventual parity error on the previously transferred SI register contents.
- Bits OD13:OD10 echo the state of bits D13, D2, D1, and D0 (SOA3:SOA0) of the previously received SI word.
- Bit OD9: Normal mode (NM) reports the device state. In Normal Mode, NM = 1.
- Bits OD8:OD0 are the contents of the selected SO register (addressed by bit D13 and bits D2:D0 of the previous SI STATR register).



### PREVIOUS ADDRESS SOA<sub>3</sub>:SOA<sub>0</sub> = 0000 (STATR)

When bits SOA3...SOA0 of the previously received SI STATR\_s register = 0000, the SO STATR register will be addressed. Bits OD8:OD0 contain the relevant channel information: Faults, channel state, and supply voltage errors.

- Bits OD8:OD6 report failures common to both channels
- Bit OD8 = OV = 1: over-voltage fault
- Bit OD7 = UV = 1: under-voltage fault
- Bit OD6 = POR = 1: power-on reset (POR) has occurred

Power-ON-Reset occurs when  $V_{PWR} < V_{SUPPLY(POR)}$ . The OV, UV, and POR bits can be reset by a reading the STATR register.

Bits OD5:OD4 of the STATR register are set to logic [1] when the auto-retry counter of the corresponding channel is full. These bits can be reset by resetting the corresponding auto-retry counter (see [Reset of the Auto-retry Counter](#))

Bits OD3 (FAULT1) and OD2 (FAULT0) are set to logic [1] when channel-specific (non-generic) faults are detected:

FAULTs = OC\_s + SC\_s + OT\_s + OS\_s + OLOFF\_s + OLON\_s.

The FAULTS bit can be reset by reading out the common STATR register or the individual FAULTR\_s register (provided the fault has disappeared).

Bits OD1:OD0 (OUT1 and OUT0) report the channel's switching state (On/Off) in real time.

### PREVIOUS ADDRESS SOA<sub>3</sub>:SOA<sub>0</sub> = A<sub>0</sub>001 (FAULTR\_S)

Bit OD8 of both Fault registers (FAULTR\_s) is set simultaneously when the over-temperature prewarning (OTW) condition occurs, but the channels are not switched off (temperature of the common GND pin (#14) > T<sub>OTWAR</sub>).

Reading either FAULT register clears both OTW bits.

Bits OD5:OD0 of the Fault register (FAULTR\_s) report the faults that occurred on the channel previously selected by bit SOA3 = A<sub>0</sub> (Table 13).

- bit OD0 = OC\_s: over-current fault on channel s,
- bit OD1 = SC\_s: severe short-circuit on channel s,
- bit OD3 = OS\_s: output shorted to V<sub>PWR</sub> on channel s,
- bit OD4 = OLOFF\_s: open-load in OFF state on channel s,
- bit OD5 = OLON\_s: open-load in ON state on channel s. (The threshold value above which this fault is triggered depends on the selected current sense ratio; for CSR0 @ 300 mA typ. and for CSR1 @ 7.0 mA typ.).

The Fault Status pin (FSB) is set to 0 (active Low) upon occurrence of any of the above mentioned faults. Latched faults can only be delatched by the procedure described in [Fault Delatching](#).

The FAULTR\_s register is reset when it is read out, provided that the failure cause has disappeared and latched faults had been delatched.

### PREVIOUS ADDRESS SOA<sub>3</sub>:SOA<sub>0</sub> = A<sub>0</sub>010 (PWMR\_S)

The device outputs the contents of the addressed PWMR\_s register (A<sub>0</sub> = 0 for bank 0 and A<sub>0</sub> = 1 for bank 1).

### PREVIOUS ADDRESS SOA<sub>3</sub>:SOA<sub>0</sub> = A<sub>0</sub>011 (CONFR\_S)

The device outputs the contents of the addressed CONFR\_s register (A<sub>0</sub> = 0 for bank 0 and A<sub>0</sub> = 1 for bank 1).

### PREVIOUS ADDRESS SOA<sub>3</sub>:SOA<sub>0</sub> = A<sub>0</sub>100 (OCR\_S)

The device outputs the contents of the addressed OCR\_s register (A<sub>0</sub> = 0 for bank 0 and A<sub>0</sub> = 1 for bank 1).

### PREVIOUS ADDRESS SOA<sub>3</sub>:SOA<sub>0</sub> = A<sub>0</sub>101 (RETRYR\_S)

The device outputs the contents of the addressed RETRYR\_s register (A<sub>0</sub> = 0 for bank 0 and A<sub>0</sub> = 1 for bank 1).

Bit OD8 contains the value of the OFP bit (offset positive), used for current sense offset compensation. Bits OD7:OD4 contain the real time value of the auto-retry counter. When these bits contain [0000], either auto-retry has not been enabled or Auto-retry did not occur.

### PREVIOUS ADDRESS SOA<sub>3</sub>:SOA<sub>0</sub> = 0110 (GCR)

The device outputs the contents of the General Configuration Register (GCR) common to both channels.

### PREVIOUS ADDRESS SOA<sub>3</sub>:SOA<sub>0</sub> = 0111 (DIAGR\_S)

Bit OD8 ( Ch. 1 = CONF1) and bit OD7 ( Ch. 0 = CONF0) of the DIAGR\_s register contain the values of the channels' configuration bits (0 = bulb, 1 = DC motor)

Bits OD6:OD5 contain the Product Identification (ID) number, equal to 00 for the present dual 10 mΩ product.

Bits OD4:OD3 report the logic state of the direct inputs IN[1:0] in real time (1 = On, 0 = OFF), OD4 = Ch. 1, OD3 = Ch. 0.

Bit OD2 reports a logic [1] in case an external clock error occurred (if an external clock was selected by Clock\_int = 0)

Bit OD1:OD0 report logic [1] in case a calibration failure occurred during calibration of a channel's internal clock period.

## TYPICAL APPLICATIONS

Figure 21 shows the electrical circuit of a typical truck application. As an example, an external circuit is added that takes over load control in case Fail-safe mode is activated

(FSOB goes low). This circuit allows keeping full control of both channels in case of SPI failure.

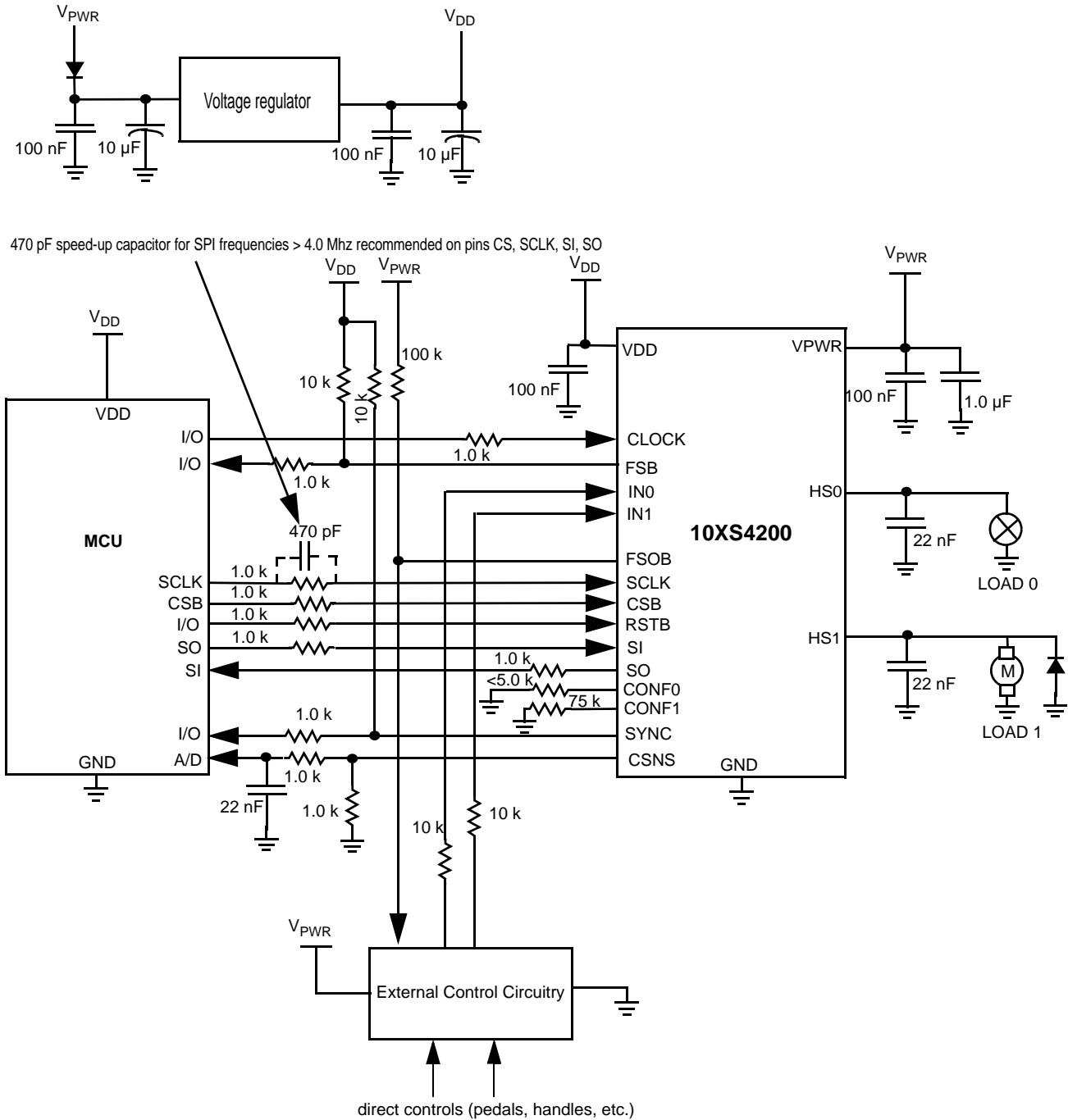

Figure 21. Typical Application with Two Different Load Types



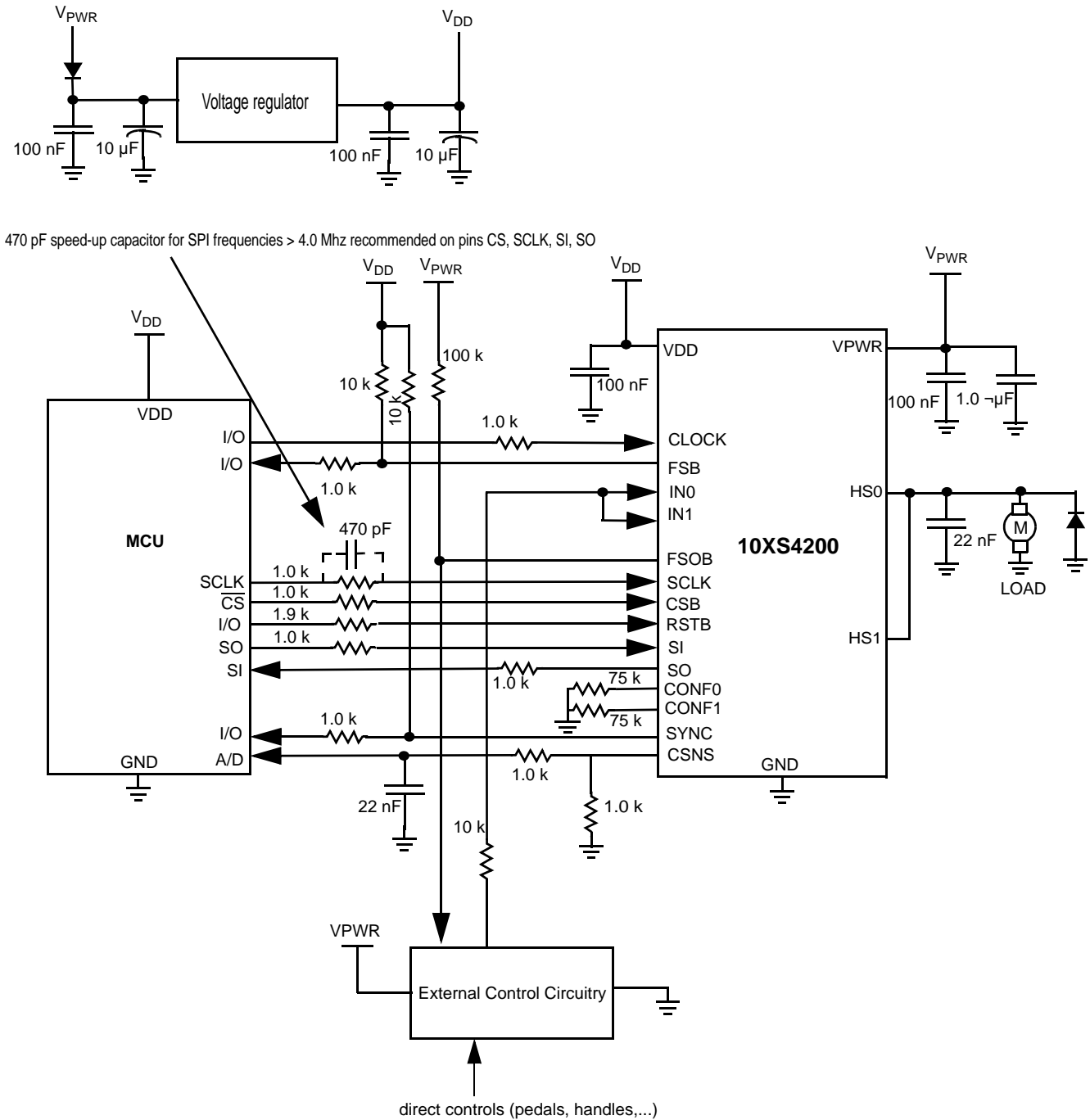

Figure 22. Two Channels in Parallel / Recommended External Current Sense Circuit

## PACKAGING

### [SOLDERING INFORMATION](#)

The 10XS4200 is packaged in a surface mount power package (PQFN), intended to be soldered directly on the printed circuit board.

The [AN2467](#) provides guidelines for Printed Circuit Board design and assembly.



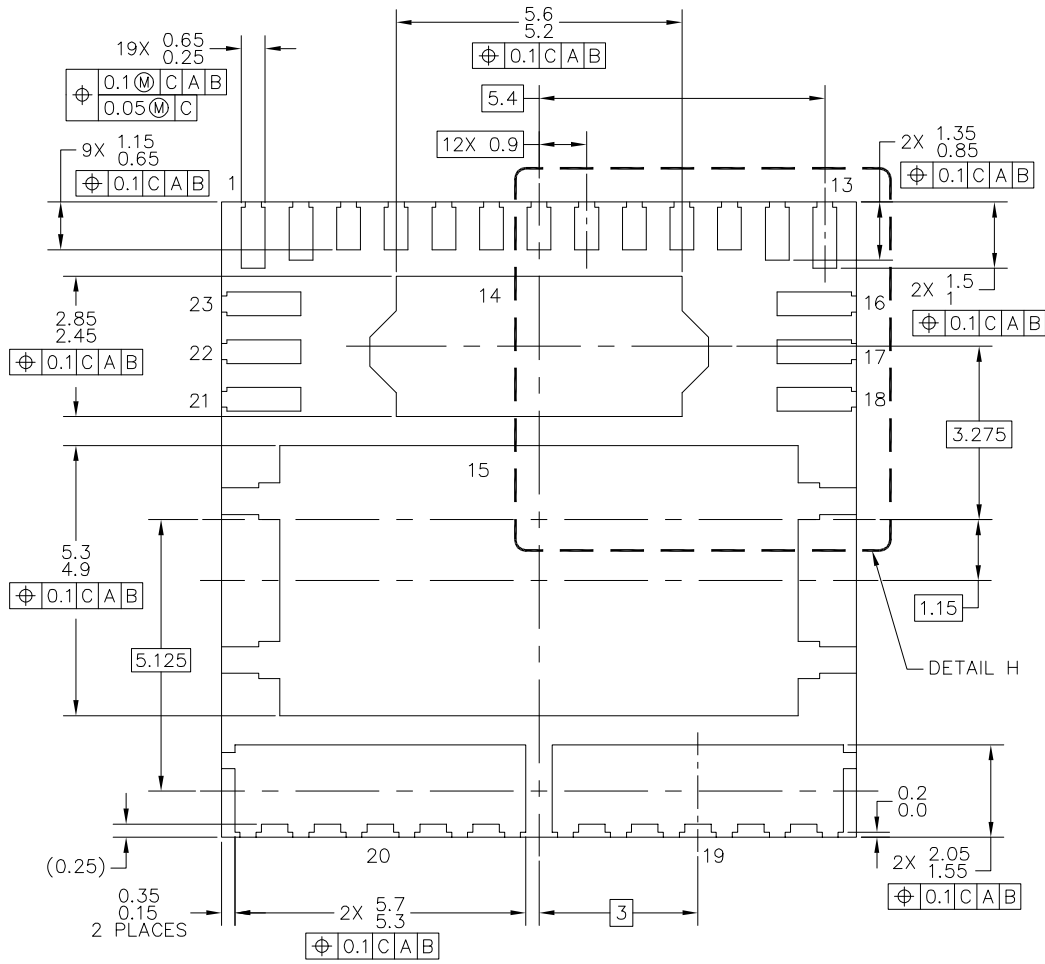

VIEW M-M

© FREESCALE SEMICONDUCTOR, INC. ALL RIGHTS RESERVED.	<b>MECHANICAL OUTLINE</b>	PRINT VERSION NOT TO SCALE	
TITLE: PQFN, 12X12X2.1, 0.9 PITCH, 23 TERMINAL	DOCUMENT NO: 98ASA00428D	REV: A	
	CASE NUMBER: 2060-01	07 MAR 2012	
	STANDARD: NON-JEDEC		

**FK SUFFIX**  
23-PIN PQFN  
98ASA00428D  
ISSUE A



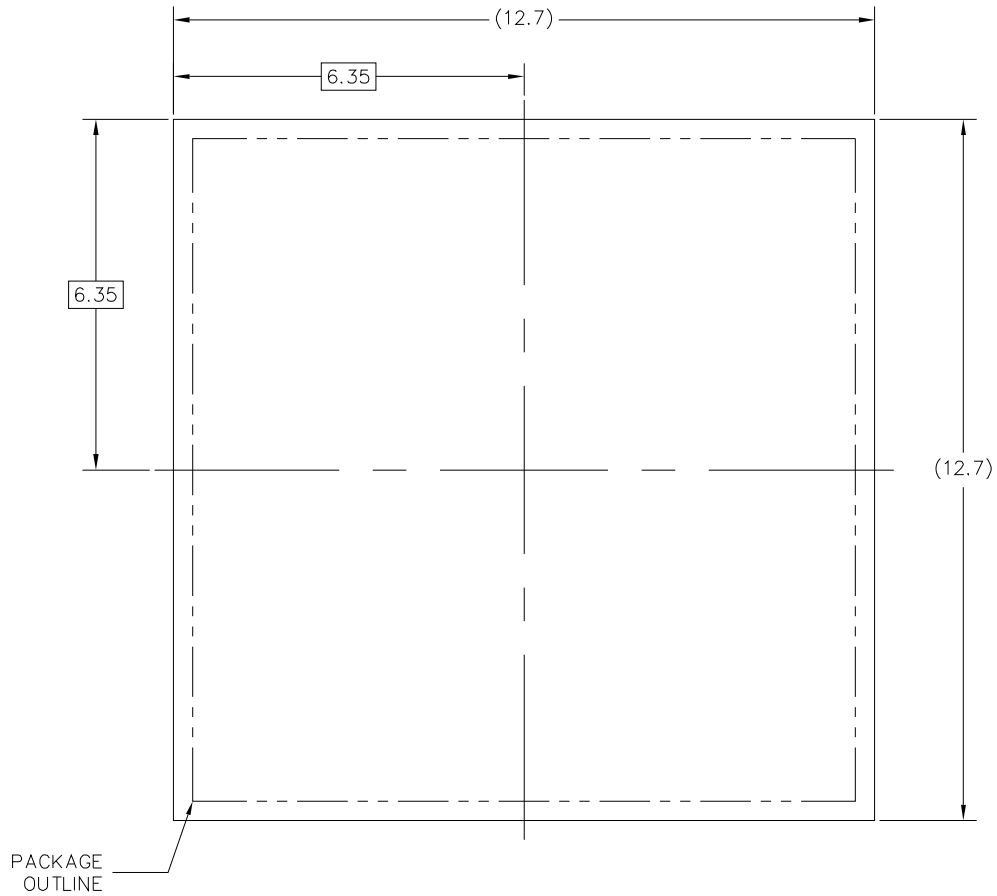

PCB DESIGN GUIDELINES – SOLDER MASK OPENING PATTERN 1

THIS SHEET SERVES ONLY AS A GUIDELINE TO HELP DEVELOP A USER SPECIFIC SOLUTION. DEVELOPMENT EFFORT WILL STILL BE REQUIRED BY END USERS TO OPTIMIZE PCB MOUNTING PROCESSES AND BOARD DESIGN IN ORDER TO MEET INDIVIDUAL / SPECIFIC REQUIREMENTS.

© FREESCALE SEMICONDUCTOR, INC. ALL RIGHTS RESERVED.	<b>MECHANICAL OUTLINE</b>	PRINT VERSION NOT TO SCALE	
TITLE: PQFN, 12X12X2.1, 0.9 PITCH, 23 TERMINAL		DOCUMENT NO: 98ASA00428D	REV: A
		CASE NUMBER: 2060-01	07 MAR 2012
		STANDARD: NON-JEDEC	

**FK SUFFIX**  
23-PIN PQFN  
98ASA00428D  
ISSUE A

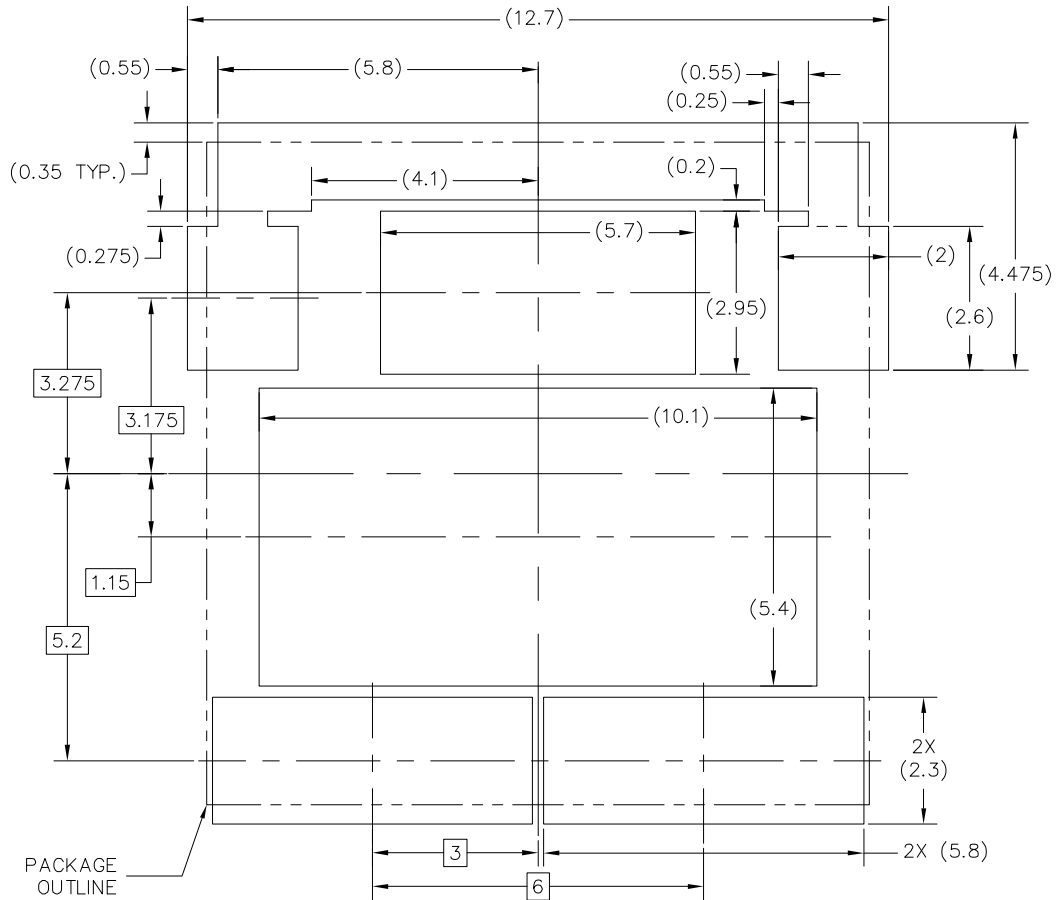

### PCB DESIGN GUIDELINES – SOLDER MASK OPENING PATTERN 2

THIS SHEET SERVES ONLY AS A GUIDELINE TO HELP DEVELOP A USER SPECIFIC SOLUTION. DEVELOPMENT EFFORT WILL STILL BE REQUIRED BY END USERS TO OPTIMIZE PCB MOUNTING PROCESSES AND BOARD DESIGN IN ORDER TO MEET INDIVIDUAL / SPECIFIC REQUIREMENTS.

© FREESCALE SEMICONDUCTOR, INC. ALL RIGHTS RESERVED.	<b>MECHANICAL OUTLINE</b>	PRINT VERSION NOT TO SCALE	
TITLE: PQFN, 12X12X2.1, 0.9 PITCH, 23 TERMINAL		DOCUMENT NO: 98ASA00428D	REV: A
		CASE NUMBER: 2060-01	07 MAR 2012
		STANDARD: NON-JEDEC	

**FK SUFFIX**  
23-PIN PQFN  
98ASA00428D  
ISSUE A

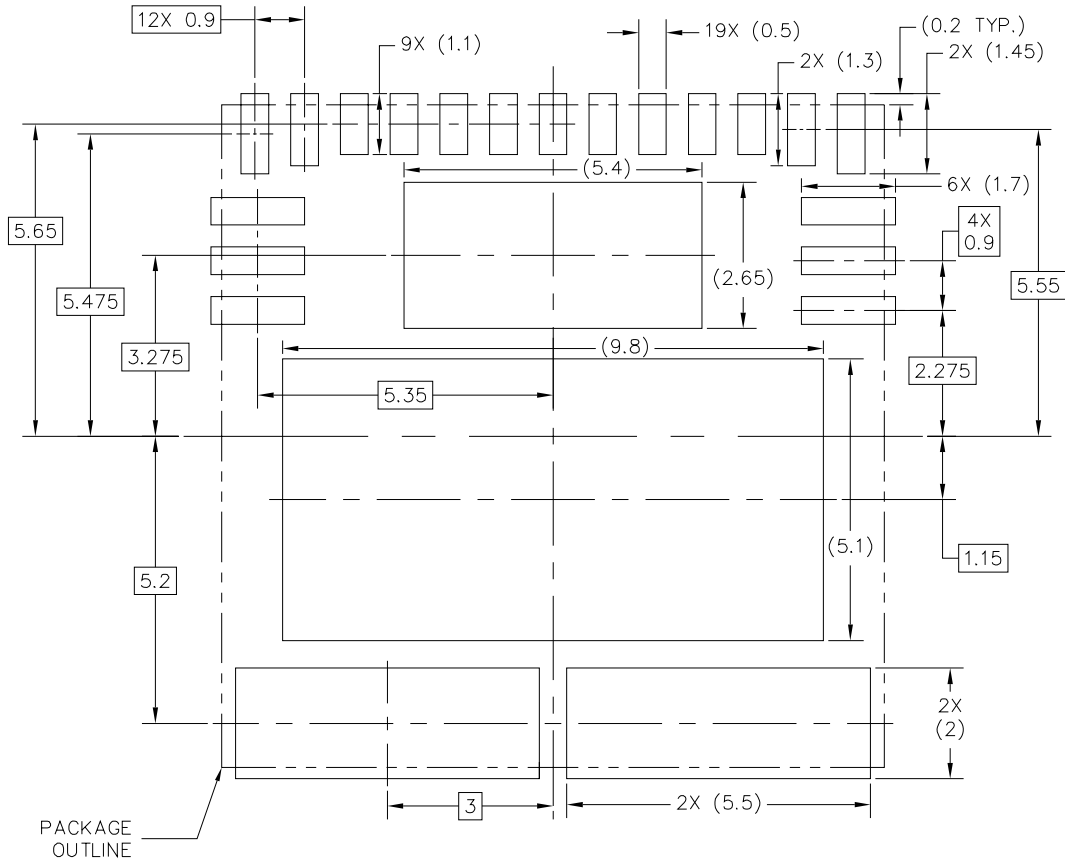

PCB CU GUIDELINES – I/O PADS & SOLDERABLE AREAS

THIS SHEET SERVES ONLY AS A GUIDELINE TO HELP DEVELOP A USER SPECIFIC SOLUTION. DEVELOPMENT EFFORT WILL STILL BE REQUIRED BY END USERS TO OPTIMIZE PCB MOUNTING PROCESSES AND BOARD DESIGN IN ORDER TO MEET INDIVIDUAL / SPECIFIC REQUIREMENTS.

© FREESCALE SEMICONDUCTOR, INC. ALL RIGHTS RESERVED.	<b>MECHANICAL OUTLINE</b>	PRINT VERSION NOT TO SCALE	
TITLE: PQFN, 12X12X2.1, 0.9 PITCH, 23 TERMINAL		DOCUMENT NO: 98ASA00428D	REV: A
		CASE NUMBER: 2060-01	07 MAR 2012
		STANDARD: NON-JEDEC	

**FK SUFFIX**  
23-PIN PQFN  
98ASA00428D  
ISSUE A



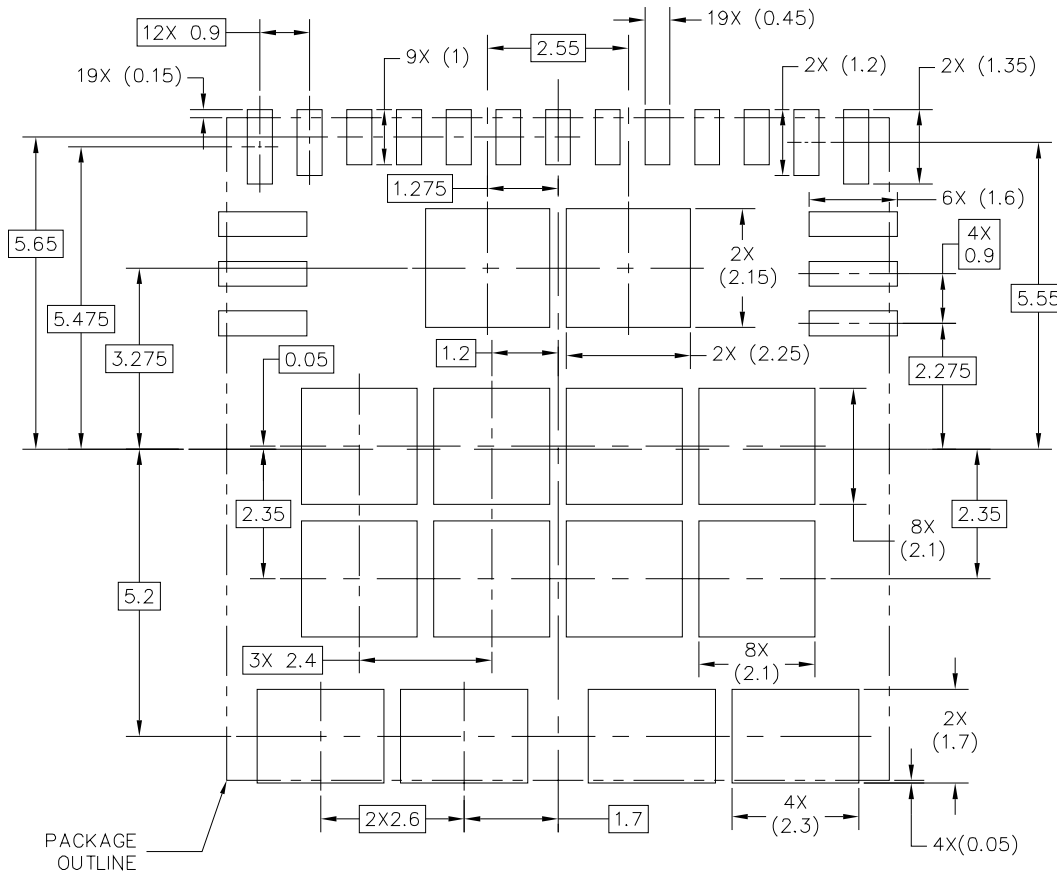

### SOLDER PASTE STENCIL GUIDELINES

THIS SHEET SERVES ONLY AS A GUIDELINE TO HELP DEVELOP A USER SPECIFIC SOLUTION. DEVELOPMENT EFFORT WILL STILL BE REQUIRED BY END USERS TO OPTIMIZE PCB MOUNTING PROCESSES AND BOARD DESIGN IN ORDER TO MEET INDIVIDUAL / SPECIFIC REQUIREMENTS.

© FREESCALE SEMICONDUCTOR, INC. ALL RIGHTS RESERVED.	<b>MECHANICAL OUTLINE</b>	PRINT VERSION NOT TO SCALE	
TITLE: PQFN, 12X12X2.1, 0.9 PITCH, 23 TERMINAL		DOCUMENT NO: 98ASA00428D	REV: A
		CASE NUMBER: 2060-01	07 MAR 2012
		STANDARD: NON-JEDEC	

**FK SUFFIX**  
23-PIN PQFN  
98ASA00428D  
ISSUE A

NOTES:

1. ALL DIMENSIONS ARE IN MILLIMETERS.
2. DIMENSIONING AND TOLERANCING PER ASME Y14.5M-1994.
3. THE COMPLETE JEDEC DESIGNATOR FOR THIS PACKAGE IS: HF-PQFP-N.
4.  COPLANARITY APPLIES TO LEADS AND CORNER LEADS.
5. MINIMUM METAL GAP IS GUARANTEED TO BE 0.25 MM.

© FREESCALE SEMICONDUCTOR, INC. ALL RIGHTS RESERVED.	<b>MECHANICAL OUTLINE</b>	PRINT VERSION NOT TO SCALE	
TITLE: PQFN, 12X12X2.1, 0.9 PITCH, 23 TERMINAL	DOCUMENT NO: 98ASA00428D	REV: A	
	CASE NUMBER: 2060-01	07 MAR 2012	
	STANDARD: NON-JEDEC		

**FK SUFFIX**  
 23-PIN PQFN  
 98ASA00428D  
 ISSUE A

## REVISION HISTORY

REVISION	DATE	DESCRIPTION OF CHANGES
1.0	4/2012	<ul style="list-style-type: none"><li>Initial release</li></ul>
2.0	6/2012	<ul style="list-style-type: none"><li>Updated the values in <a href="#">Table 4, Dynamic Electrical Characteristics</a></li><li>Updated the values in <a href="#">E<sub>SR1_ERR</sub></a></li></ul>

---

**How to Reach Us:**

**Home Page:**

freescale.com

**Web Support:**

freescale.com/support

Information in this document is provided solely to enable system and software implementers to use Freescale products. There are no express or implied copyright licenses granted hereunder to design or fabricate any integrated circuits on the information in this document.

Freescale reserves the right to make changes without further notice to any products herein. Freescale makes no warranty, representation, or guarantee regarding the suitability of its products for any particular purpose, nor does Freescale assume any liability arising out of the application or use of any product or circuit, and specifically disclaims any and all liability, including without limitation consequential or incidental damages. "Typical" parameters that may be provided in Freescale data sheets and/or specifications can and do vary in different applications, and actual performance may vary over time. All operating parameters, including "typicals," must be validated for each customer application by customer's technical experts. Freescale does not convey any license under its patent rights nor the rights of others. Freescale sells products pursuant to standard terms and conditions of sale, which can be found at the following address: <http://www.reg.net/v2/webservices/Freescale/Docs/TermsandConditions.htm>

Freescale, the Freescale logo, Altivec, C-5, CodeTest, CodeWarrior, ColdFire, C-Ware, Energy Efficient Solutions logo, mobileGT, PowerQUICC, QorIQ, Qorivva, StarCore, and Symphony are trademarks of Freescale Semiconductor, Inc., Reg. U.S. Pat. & Tm. Off. Airfast, BeeKit, BeeStack, ColdFire+, CoreNet, Flexis, MagniV, MXC, Platform in a Package, Processor expert, QorIQ Qonverge, QUICC Engine, Ready Play, SMARTMOS, TurboLink, Vybrid, and Xtrinsic are trademarks of Freescale Semiconductor, Inc. All other product or service names are the property of their respective owners.

© 2012 Freescale Semiconductor, Inc.

Document Number: MC10XS4200

Rev. 2.0

6/2012

