

Transient Voltage Suppressors (TVS) Data Sheet

Features

- 1500W peak pulse power capability at 10/1000μs waveform, repetition rate (duty cycle): 0.01%
- Plastic package has underwriters laboratory flammability 94V-0
- Meets MSL level 1, per J-STD-020
- High Temperature soldering: 260°C/10 seconds at terminals
- Typical I_R less than 1μA above 10V
- For surface mounted applications in order to optimize board space
- Low profile package
- Built-in strain relief
- Glass passivated junction
- Low inductance
- Excellent clamping capability
- Fast response time

Mechanical Data

- Weight: 0.26g
- Standard Packaging: 16mm tape (EIA STD RS-481)
- Case: JEDEC DO-214AB. Molded plastic over glass passivated junction
- Terminal: Solder plated, solderable per MIL-STD-750, Method 2026
- Polarity: Color band denotes cathode except bi-directional models

Applications

- I/O interface ■ AC/DC power supply ■ Vcc bus
- Low frequency signal transmission line (RS232, RS485, etc.)

Maximum Ratings and Characteristics

Ratings at 25°C ambient temperature unless otherwise specified.

Rating	Symbol	Value	Units
Peak pulse power dissipation at 10/1000μs waveform (Note1, Note2, Fig.1)	P_{PPM}	Minimum 1500	Watts
Peak pulse current of at 10/1000μs waveform (Note 1, Fig.3)	I_{PPM}	See Table	Amps
Steady state power dissipation at $T_A=50^\circ\text{C}$ (Fig.5)	$P_{M(AV)}$	6.5	Watts
Peak forward surge current, 8.3ms single half sine-wave superimposed on rated load, (JEDEC Method) (Note3, Fig.6)	I_{FSM}	200	Amps
Operating junction and Storage Temperature Range.	T_J, T_{STG}	-65 to +150	°C
Typical thermal resistance junction to lead	$R_{\theta JL}$	15	°C/W
Typical thermal resistance junction to ambient	$R_{\theta JA}$	75	°C/W

Notes: 1. Non-repetitive current pulse, per Fig.3 and derated above $T_A=25^\circ\text{C}$ per Fig.2.

2. Mounted on 8.0mm×8.0mm (0.03mm thick) copper pads to each terminal.

3. 8.3ms single half sine-wave, or equivalent square wave, duty cycle=4 pulses per minutes maximum.

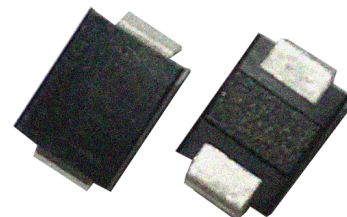

Functional Diagram

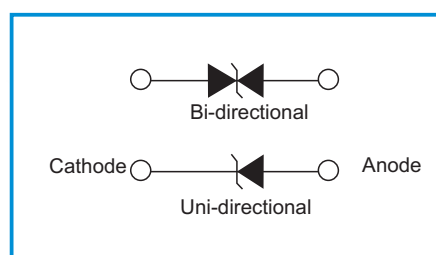

Dimensions

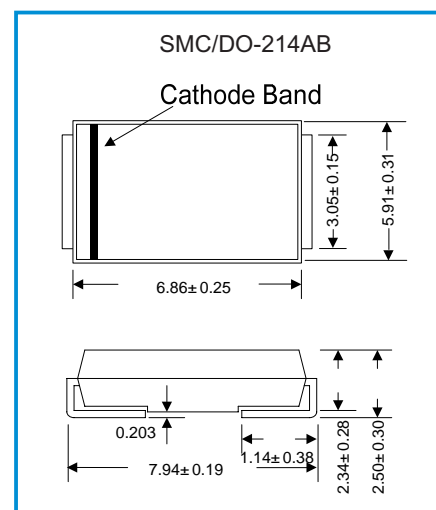

Electrical Characteristics (T_A=25°C)

Part Number (Uni)	Part Number (Bi)	Marking		Reverse Stand off Voltage V _R (Volts)	Breakdown Voltage V _{BR} (Volts)@ I _T		Test Current I _T (mA)	Maximum Clamping Voltage V _C @ I _{PP} (V)	Maximum Peak Pulse Current I _{PP} (A)	Maximum Reverse Leakage I _R @ V _R (μA)
		UNI	BI		MIN	MAX				
1.5SMCJ6.8A	1.5SMCJ6.8CA	6V8A	6V8C	5.80	6.45	7.14	10	10.5	144.8	500
1.5SMCJ7.5A	1.5SMCJ7.5CA	7V5A	7V5C	6.40	7.13	7.88	10	11.3	134.5	400
1.5SMCJ8.2A	1.5SMCJ8.2CA	8V2A	8V2C	7.02	7.79	8.61	10	12.1	125.6	100
1.5SMCJ9.1A	1.5SMCJ9.1CA	9V1A	9V1C	7.78	8.65	9.55	1	13.4	113.4	20
1.5SMCJ10A	1.5SMCJ10CA	10A	10C	8.55	9.50	10.50	1	14.5	104.8	10
1.5SMCJ11A	1.5SMCJ11CA	11A	11C	9.40	10.50	11.60	1	15.6	97.4	1
1.5SMCJ12A	1.5SMCJ12CA	12A	12C	10.20	11.40	12.60	1	16.7	91.0	1
1.5SMCJ13A	1.5SMCJ13CA	13A	13C	11.10	12.40	13.70	1	18.2	83.5	1
1.5SMCJ15A	1.5SMCJ15CA	15A	15C	12.80	14.30	15.80	1	21.2	71.7	1
1.5SMCJ16A	1.5SMCJ16CA	16A	16C	13.60	15.20	16.80	1	22.5	67.6	1
1.5SMCJ18A	1.5SMCJ18CA	18A	18C	15.30	17.10	18.90	1	25.2	60.3	1
1.5SMCJ20A	1.5SMCJ20CA	20A	20C	17.10	19.00	21.00	1	27.7	54.9	1
1.5SMCJ22A	1.5SMCJ22CA	22A	22C	18.80	20.90	23.10	1	30.6	49.7	1
1.5SMCJ24A	1.5SMCJ24CA	24A	24C	20.50	22.80	25.20	1	33.2	45.8	1
1.5SMCJ27A	1.5SMCJ27CA	27A	27C	23.10	25.70	28.40	1	37.5	40.5	1
1.5SMCJ30A	1.5SMCJ30CA	30A	30C	25.60	28.50	31.50	1	41.4	36.7	1
1.5SMCJ33A	1.5SMCJ33CA	33A	33C	28.20	31.40	34.70	1	45.7	33.3	1
1.5SMCJ36A	1.5SMCJ36CA	36A	36C	30.80	34.20	37.80	1	49.9	30.5	1
1.5SMCJ39A	1.5SMCJ39CA	39A	39C	33.30	37.10	41.00	1	53.9	28.2	1
1.5SMCJ43A	1.5SMCJ43CA	43A	43C	36.80	40.90	45.20	1	59.3	25.6	1
1.5SMCJ47A	1.5SMCJ47CA	47A	47C	40.20	44.70	49.40	1	64.8	23.5	1
1.5SMCJ51A	1.5SMCJ51CA	51A	51C	43.60	48.50	53.60	1	70.1	21.7	1
1.5SMCJ56A	1.5SMCJ56CA	56A	56C	47.80	53.20	58.80	1	77.0	19.7	1
1.5SMCJ62A	1.5SMCJ62CA	62A	62C	53.00	58.90	65.10	1	85.0	17.9	1
1.5SMCJ68A	1.5SMCJ68CA	68A	68A	58.10	64.60	71.40	1	92.0	16.5	1
1.5SMCJ75A	1.5SMCJ75CA	75A	75C	64.10	71.30	78.80	1	103.0	14.8	1
1.5SMCJ82A	1.5SMCJ82CA	82A	82C	70.10	77.90	86.10	1	113.0	13.5	1
1.5SMCJ91A	1.5SMCJ91CA	91A	91C	77.80	86.50	95.50	1	125.0	12.2	1
1.5SMCJ100A	1.5SMCJ100CA	100A	100C	85.50	95.00	105.00	1	137.0	11.1	1
1.5SMCJ110A	1.5SMCJ110CA	110A	110C	94.00	105.00	116.00	1	152.0	10.0	1
1.5SMCJ120A	1.5SMCJ120CA	120A	120C	102.00	114.00	126.00	1	165.0	9.2	1
1.5SMCJ130A	1.5SMCJ130CA	130A	130C	111.00	124.00	137.00	1	179.0	8.5	1
1.5SMCJ150A	1.5SMCJ150CA	150A	150C	128.00	143.00	158.00	1	207.0	7.3	1
1.5SMCJ160A	1.5SMCJ160CA	160A	160C	136.00	152.00	168.00	1	219.0	6.9	1
1.5SMCJ170A	1.5SMCJ170CA	170A	170C	145.00	162.00	179.00	1	234.0	6.5	1
1.5SMCJ180A	1.5SMCJ180CA	180A	180C	154.00	171.00	189.00	1	246.0	6.2	1
1.5SMCJ200A	1.5SMCJ200CA	200A	200C	171.00	190.00	210.00	1	274.0	5.5	1
1.5SMCJ220A	1.5SMCJ220CA	220A	220C	185.00	209.00	231.00	1	328.0	4.6	1
1.5SMCJ250A	1.5SMCJ250CA	250A	250C	214.00	237.00	263.00	1	344.0	4.4	1
1.5SMCJ300A	1.5SMCJ300CA	300A	300C	256.00	285.00	315.00	1	414.0	3.7	1
1.5SMCJ350A	1.5SMCJ350CA	350A	350C	300.00	332.00	368.00	1	482.0	3.2	1
1.5SMCJ400A	1.5SMCJ400CA	400A	400C	342.00	380.00	420.00	1	548.0	2.8	1
1.5SMCJ440A	1.5SMCJ440CA	440A	440C	376.00	418.00	462.00	1	602.0	2.5	1
1.5SMCJ480A	1.5SMCJ480CA	480A	480C	408.00	456.00	504.00	1	658.0	2.3	1
1.5SMCJ510A	1.5SMCJ510CA	510A	510C	434.00	485.00	535.00	1	698.0	2.1	1
1.5SMCJ530A	1.5SMCJ530CA	530A	530C	450.00	503.50	556.50	1	725.0	2.1	1
1.5SMCJ540A	1.5SMCJ540CA	540A	540C	459.00	513.00	567.00	1	740.0	2.0	1
1.5SMCJ550A	1.5SMCJ550CA	550A	550C	467.00	522.50	577.50	1	760.0	2.0	1

Notes: For bidirectional type having V_R of 10V and less, the I_R limit is double.

Ratings and Characteristic Curves ($T_A = 25^\circ\text{C}$ unless otherwise noted)

Figure 1. Peak Pulse Power Rating Curve

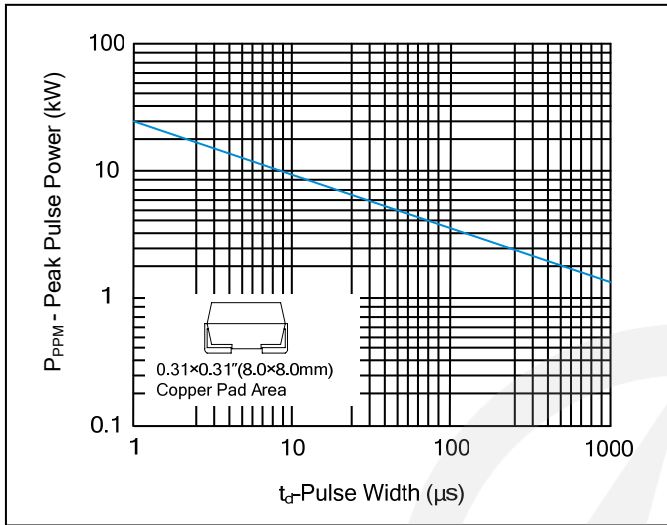

Figure 4. Typical Junction Capacitance

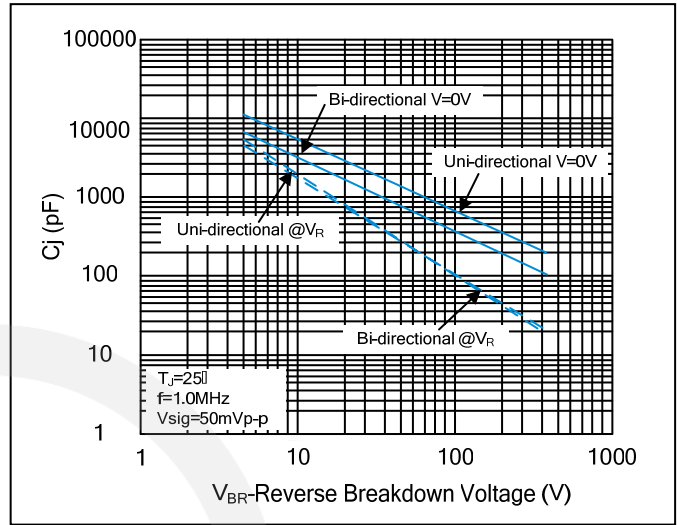

Figure 2. Pulse Derating Curve

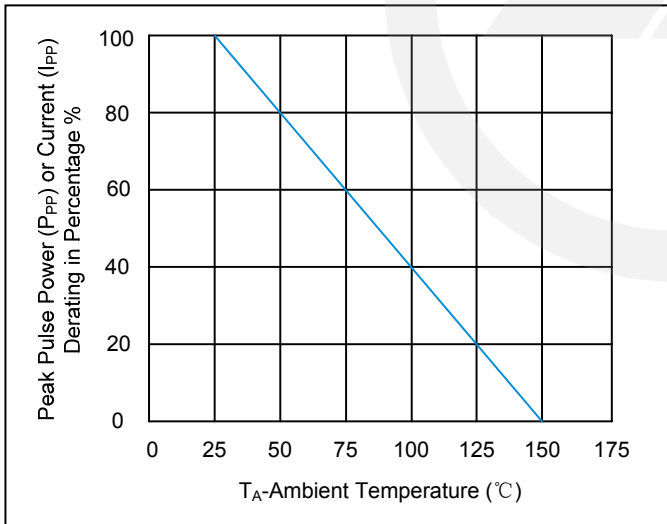

Figure 5. Steady State Power Dissipation Derating Curve

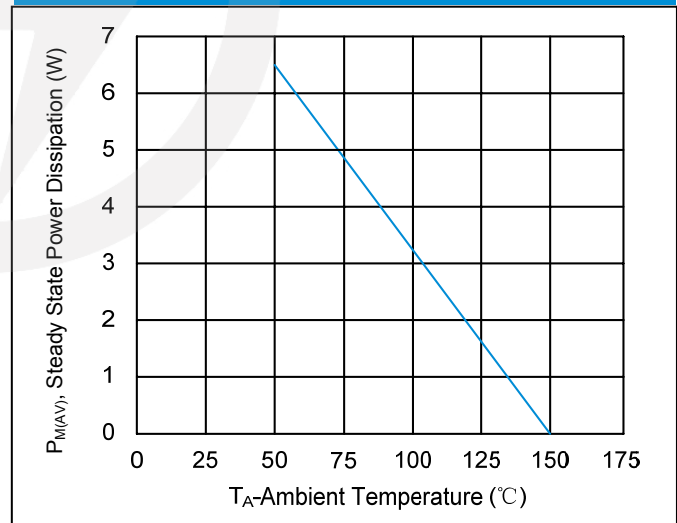

Figure 3. Pulse Waveform

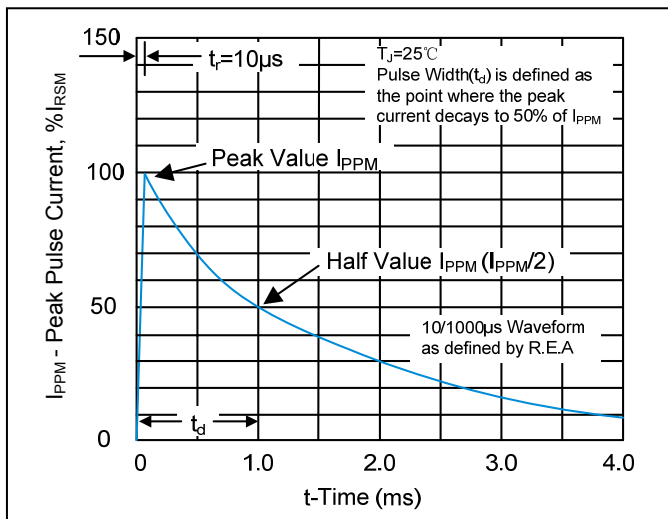
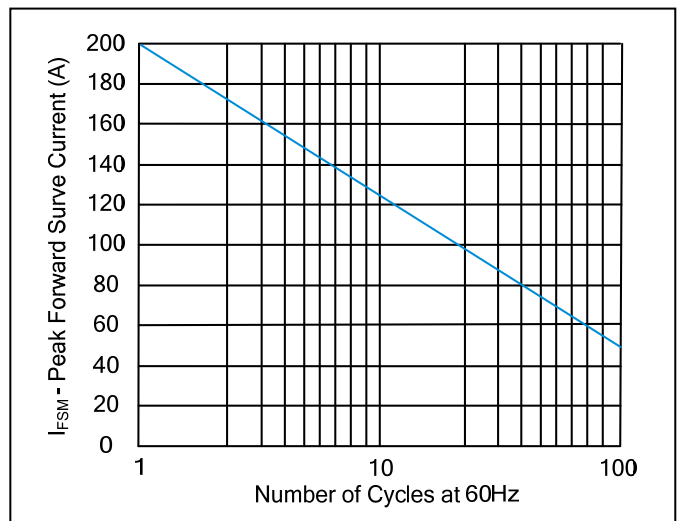
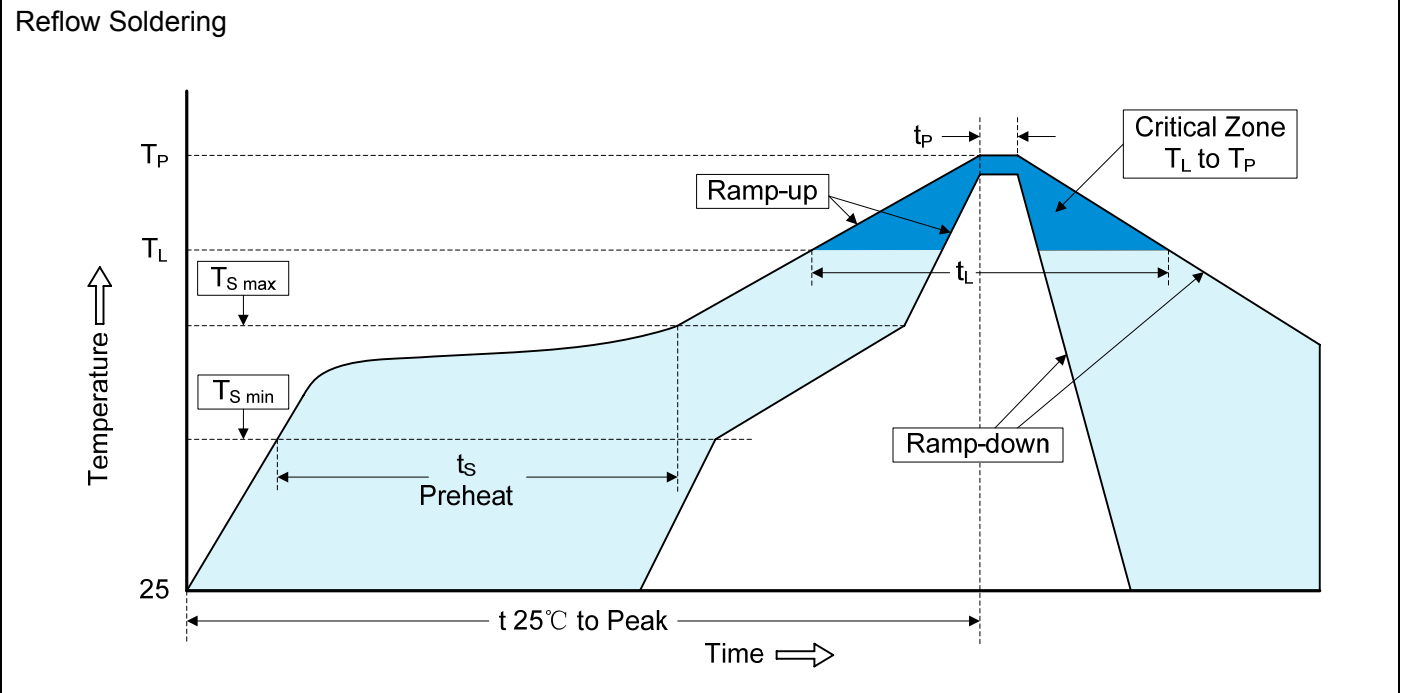

Figure 6. Maximum Non-Repetitive Forward Surge Current Uni-Directional Only



Recommended Soldering Conditions

Recommended Conditions

Profile Feature	Pb-Free Assembly
Average ramp-up rate (T_L to T_P)	3°C/second max.
Preheat -Temperature Min ($T_{S\ min}$) -Temperature Max ($T_{S\ max}$) -Time (min to max) (t_s)	150°C 200°C 60-180 seconds
$T_{S\ max}$ to T_L -Ramp-up Rate	3°C/second max.
Time maintained above: -Temperature (T_L) -Time (t_L)	217°C 60-150 seconds
Peak Temperature (T_P)	260°C
Time within 5°C of actual Peak Temperature (t_p)	20-40 seconds
Ramp-down Rate	6°C/second max.
Time 25°C to Peak Temperature	8 minutes max.

Packaging

13" Reel

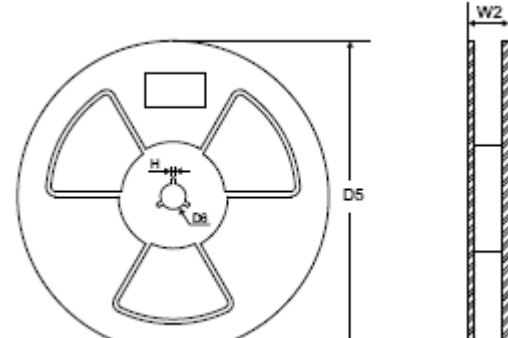

D5	$\Phi 330.0 \pm 2.0$
D6	$\Phi 13.5 \pm 0.5$
H	2.5 ± 1.0
W2	16.0 ± 2.0
Quantity: 3000PCS	