

isc N-Channel Mosfet Transistor

12N65

• FEATURES

- Drain Current $-I_D = 12A @ T_C = 25^\circ C$
- Drain Source Voltage-
: $V_{DSS} = 650V$ (Min)
- Static Drain-Source On-Resistance
: $R_{DS(on)} = 0.85 \Omega$ (Max)
- Avalanche Energy Specified
- Fast Switching
- Simple Drive Requirements

• DESCRIPTION

- Designed for high efficiency switch mode power supply.

• ABSOLUTE MAXIMUM RATINGS($T_a = 25^\circ C$)

SYMBOL	PARAMETER	VALUE	UNIT
V_{DSS}	Drain-Source Voltage	650	V
V_{GS}	Gate-Source Voltage-Continuous	± 30	V
I_D	Drain Current-Continuous	12	A
I_{DM}	Drain Current-Single Plused	48	A
P_D	Total Dissipation @ $T_C = 25^\circ C$	225	W
T_j	Max. Operating Junction Temperature	150	$^\circ C$
T_{stg}	Storage Temperature	-55~150	$^\circ C$

• THERMAL CHARACTERISTICS

SYMBOL	PARAMETER	MAX	UNIT
$R_{th j-c}$	Thermal Resistance, Junction to Case	0.56	$^\circ C/W$
$R_{th j-a}$	Thermal Resistance, Junction to Ambient	62.5	$^\circ C/W$

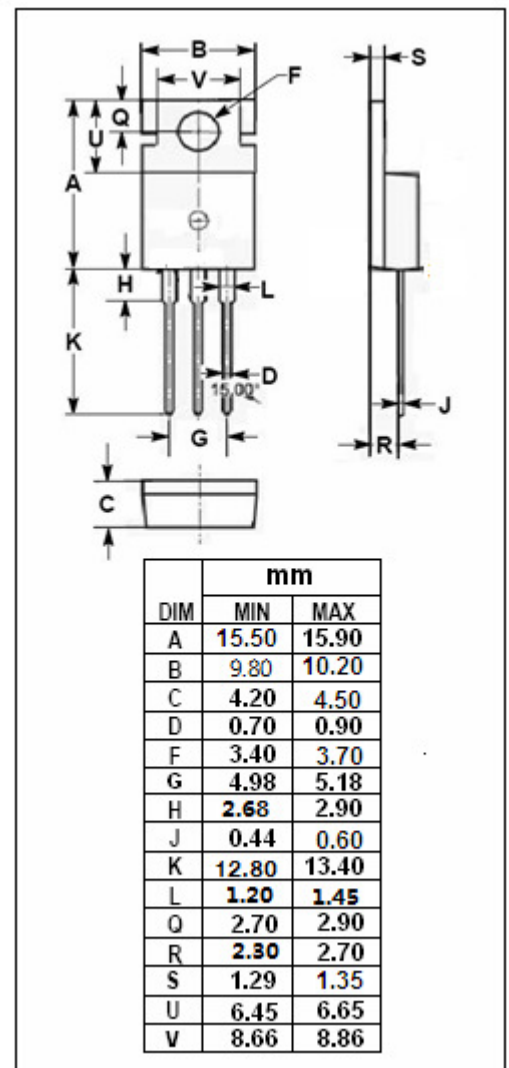
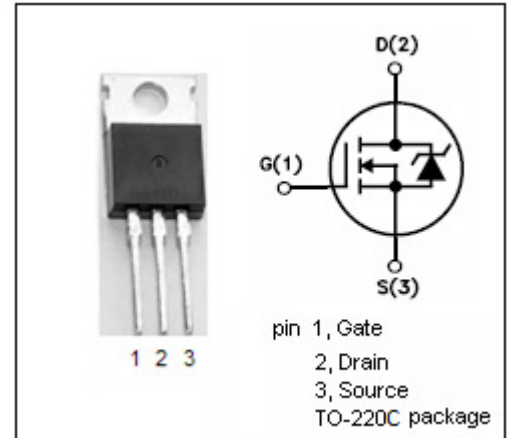

isc N-Channel Mosfet Transistor**12N65****ELECTRICAL CHARACTERISTICS** $T_C=25^{\circ}\text{C}$ unless otherwise specified

SYMBOL	PARAMETER	CONDITIONS	MIN	MAX	UNIT
$V_{(BR)DSS}$	Drain-Source Breakdown Voltage	$V_{GS}=0$; $I_D=0.25\text{mA}$	650		V
$V_{GS(th)}$	Gate Threshold Voltage	$V_{DS}=V_{GS}$; $I_D=0.25\text{mA}$	2	4	V
$R_{DS(on)}$	Drain-Source On-Resistance	$V_{GS}=10\text{V}$; $I_D=6.0\text{A}$		0.85	Ω
I_{GSS}	Gate-Body Leakage Current	$V_{GS}=\pm 30\text{V}$; $V_{DS}=0$		± 100	nA
I_{DSS}	Zero Gate Voltage Drain Current	$V_{DS}=650\text{V}$; $V_{GS}=0$		1	μA
V_{SD}	Forward On-Voltage	$I_S=12\text{A}$; $V_{GS}=0$		1.4	V