

THIS DRAWING IS UNPUBLISHED. RELEASED FOR PUBLICATION
 © COPYRIGHT 19 BY TYCO ELECTRONICS CORPORATION. ALL RIGHTS RESERVED.

LOC	DIST	REVISIONS					
		P	LTR	DESCRIPTION	DATE	DWN	APVD
GP	00		B	ADDED: -3 PER EC 0S15-0009-01	10OCT2001	DLD	DJB
			C	REVISED PER EC 0S15-0061-01	14DEC2001	DLD	TW

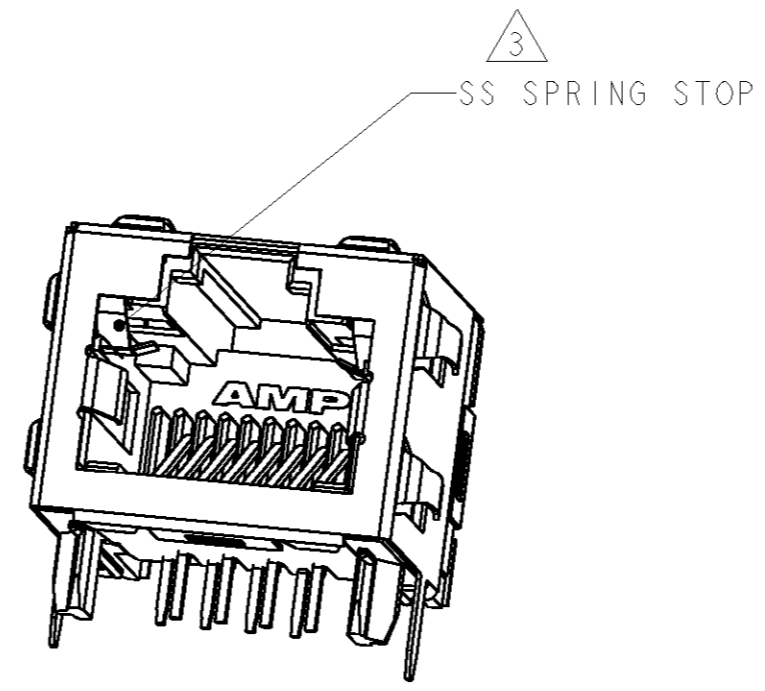

- 1 MATERIAL:
 HOUSING - HIGH TEMPERATURE THERMOPLASTIC, PER UL94V-0;
 IR REFLOW SOLDERING PROCESS COMPATIBLE.
 SEE TABLE FOR COLOR.
 TERMINALS - .014 THICK PHOSPHOR BRONZE.
 PLATING - 50 MICRO INCHES GOLD IN CONTACT AREA 150 MICRO INCHES TIN-LEAD ON SOLDER TAILS, ALL OVER 50 MICRO INCHES OF NICKEL.
 SHIELD - .0077 THICK COPPER-ZINC ALLOY PREPLATED WITH 150 MICRO INCHES OF TIN-LEAD OVER 100 MICRO INCHES COPPER.
- 2. JACK CAVITY CONFORMS TO FCC RULES AND REGULATIONS PART 68, SUBPART F.
- 3 RJ45 PLUG SELECTIVE - THIS CONNECTOR UTILIZES A STEEL SPRING MEMBER WHICH PREVENTS THE INSERTION OF A RJ11 (6 POSITION) PLUG INTO THE JACK PORT.
 WARNING: THIS FEATURE WAS DEVELOPED FOR TYPICAL PLUG INSERTION FORCES. EXCESSIVE INSERTION FORCE MAY OVERCOME THE SELECTIVE FEATURES AND DAMAGE THE CONNECTOR.

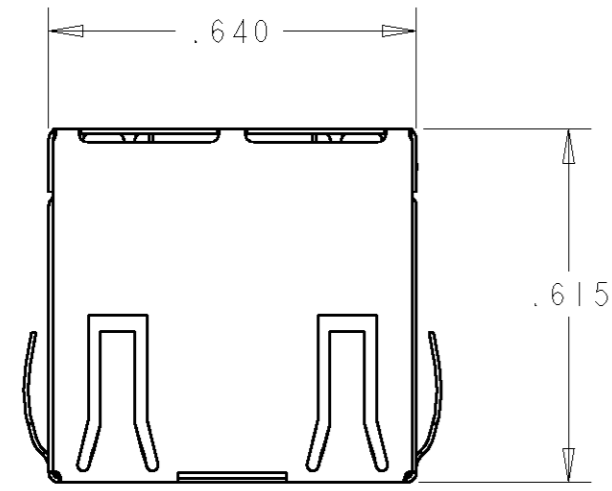
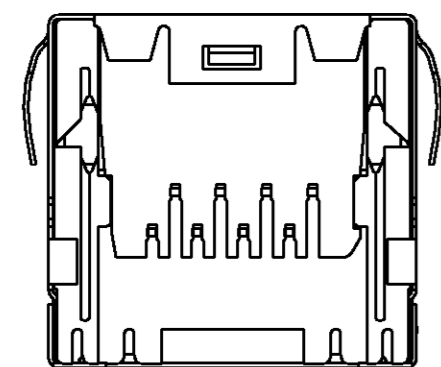
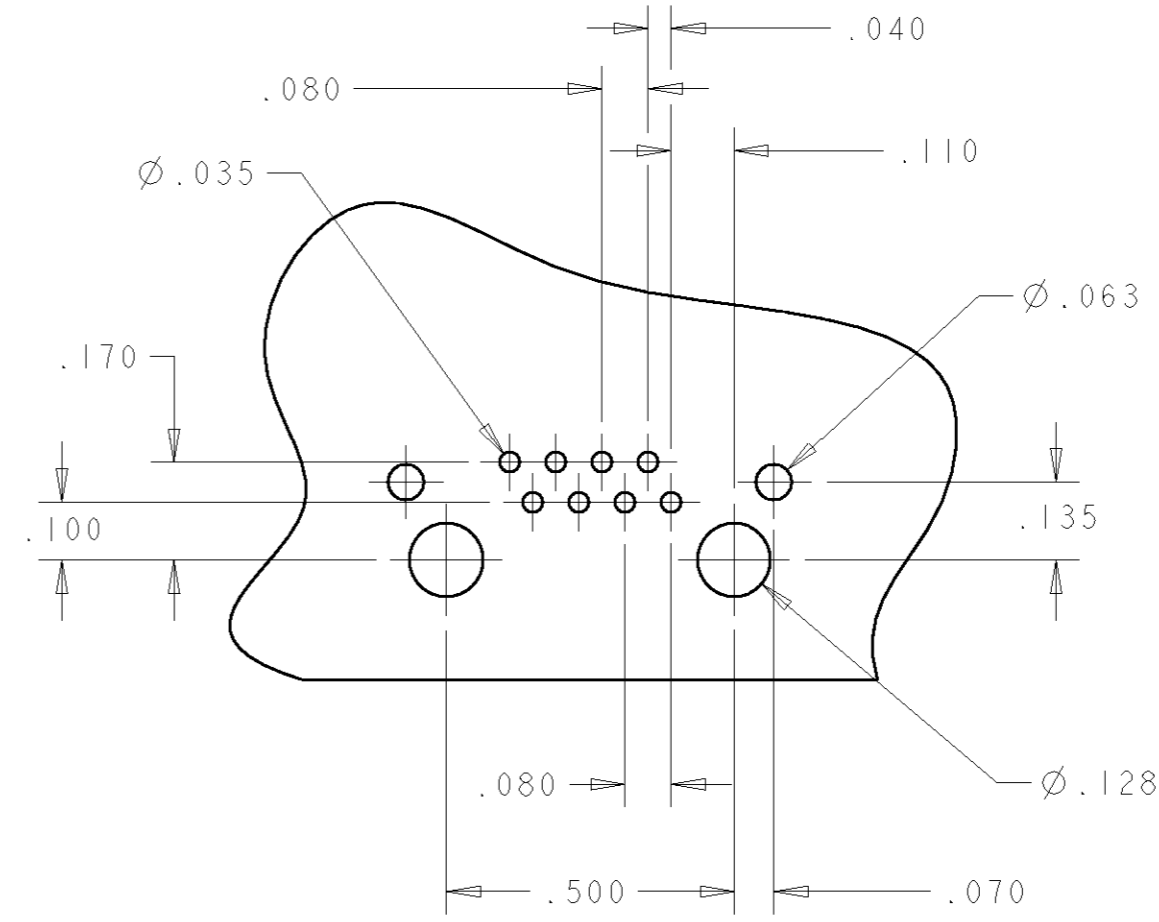
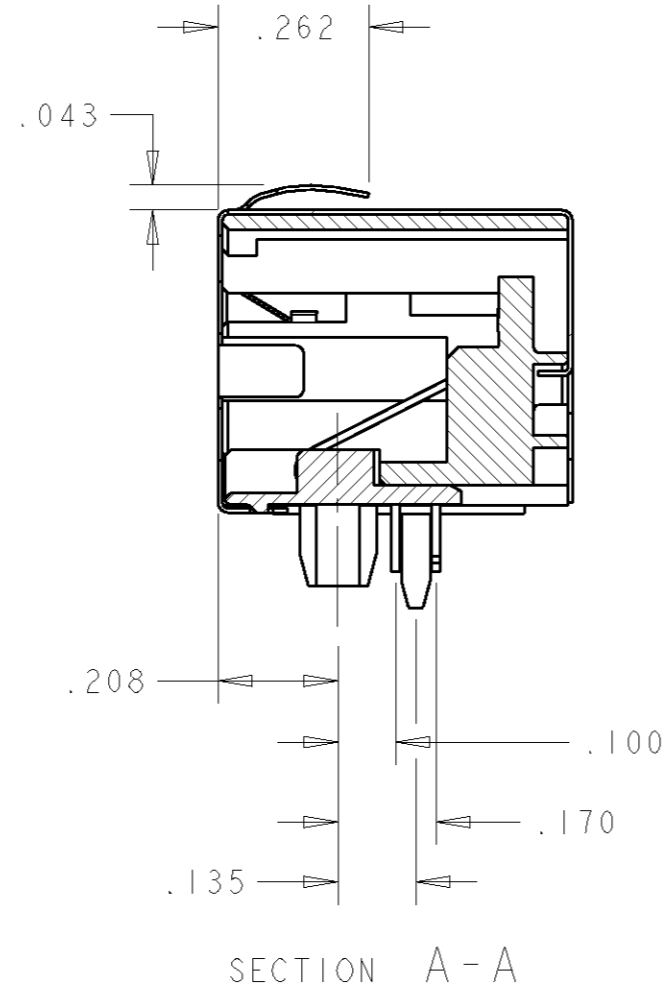
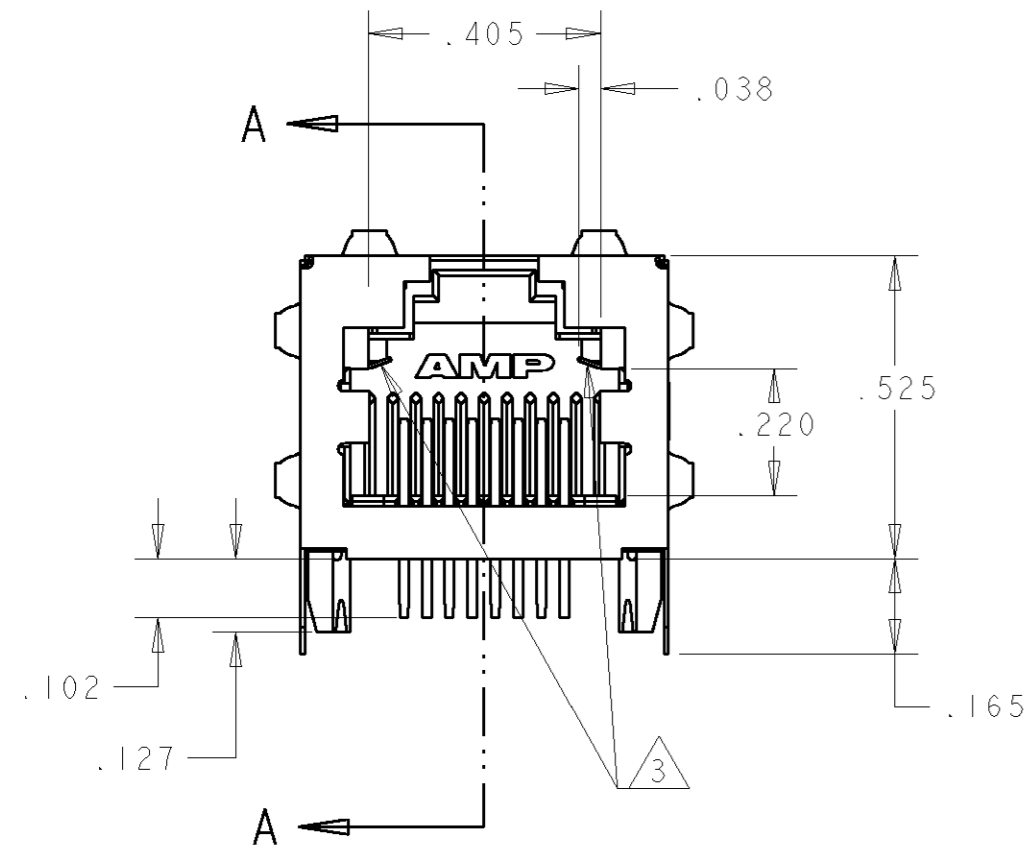

NON-METALLIC PEARL	1364288-3
BLACK	1364288-1
COLOR	PART NUMBER

THIS DRAWING IS A CONTROLLED DOCUMENT FOR TYCO ELECTRONICS CORPORATION IT IS SUBJECT TO CHANGE AND THE CONTROLLING ENGINEERING ORGANIZATION SHOULD BE CONTACTED FOR THE LATEST REVISION.		DWN A. HASIRCOW	07FEB00	AMP Incorporated Harrisburg, PA 17105-3608
DIMENSIONS: INCHES		CHK D. DIXON	25MAY00	
TOLERANCES UNLESS OTHERWISE SPECIFIED:		APVD D. SUMMERS	25MAY00	
0 PLC ± 1 PLC ± 2 PLC ±.01 3 PLC ±.005 4 PLC ±.0020 ANGLES ±° FINISH		PRODUCT SPEC	-	
MATERIAL		APPLICATION SPEC	-	NAME RJ45 PLUG SELECTIVE RECEPTACLE ASSEMBLY
		WEIGHT	-	SIZE A2
		CUSTOMER DRAWING		CAGE CODE 00779
				DRAWING NO 1364288
				RESTRICTED TO -
				SCALE 3:1
				SHEET 1
				OF 1
				REV C