

EXAMINED BY :	EMERGING DISPLAY TECHNOLOGIES CORPORATION	FILE NO . CAS-0006590
<i>Kevin Kuo</i>		ISSUE : FEB.25, 2008
APPROVED BY:		TOTAL PAGE : 11
<i>David Chang</i>		VERSION : 2

CUSTOMER ACCEPTANCE SPECIFICATIONS

MODEL NO. :

1 3 B A 2 (LED TYPES)

(RoHS)

FOR MESSRS :

CUSTOMER'S APPROVAL

DATE :

BY :

EMERGING DISPLAY
TECHNOLOGIES CORPORATION

MODEL NO. 1 3 B A 2 (LED TYPES)	VERSION 2	PAGE 0-1
------------------------------------	--------------	-------------

RECORDS OF REVISION	DOC . FIRST ISSUE	JAN.31, 2008
---------------------	-------------------	--------------

DATE	REVISED PAGE NO.	SUMMARY
FEB.25, 2008	1	1.2 APPLICATION NOTES FOR CONTROLLER/DRIVER PLEASE REFER TO : LCD DRIVER / NT75451 → NOVATEK / NT75451
	5	5.2 RESET TIMING LINTERNAL → INTERNAL
	7	7. OUTLINE DIMENSIONS MARK △ : ADD FPC BENDING AREA
	9	9. BLOCK DIAGRAM COM0 → C1, COM31 → C32, COM32 → COMS, PIN 20 : V0 → NC, SEG127 → SEG131
	11	11.1 POWER SUPPLY FOR LCM(VDD = 4.0V~5.0V) → 11.1 POWER SUPPLY FOR LCM 3.0~3.6V → 3.3V

NUMBERING SYSTEM

Polarizer Mode	Backlight	Code value
Transflective	LED	L
Transmissive	LED	M

E S 1 3 B A 2 G L Y

LCD type + color	Code Value
STN + Yellow-Green	Y
STN + Gray	G
FSTN + White	F
STN + Blue	B
STN + Black	N

TABLE OF CONTENTS

NO.	ITEM	PAGE
1.	GENERAL SPECIFICATIONS -----	1
2.	MECHANICAL SPECIFICATIONS -----	1
3.	ABSOLUTE MAXIMUM RATINGS -----	2
4.	ELECTRICAL CHARACTERISTICS -----	3
5.	TIME CHARACTERISTICS -----	4 , 5
6.	OPTICAL CHARACTERISTICS -----	6
7.	OUTLINE DIMENSIONS -----	7
8.	DETAIL DRAWING OF DOT MATRIX -----	8
9.	BLOCK DIAGRAM -----	9
10.	INTERFACE SIGNALS -----	10
11.	POWER SUPPLY -----	11

1. GENERAL SPECIFICATIONS

1.1 GENERAL SPECIFICATIONS

PLEASE REFER TO :

CUSTOMER ACCEPTANCE STANDARD SPECIFICATIONS :

EU-002B

1.2 APPLICATION NOTES FOR CONTROLLER/DRIVER

PLEASE REFER TO :

NOVATEK / NT75451

1.3 MATERIAL SAFETY DESCRIPTION

ASSEMBLIES SHALL COMPLY WITH EUROPEAN ROHS REQUIREMENTS, INCLUDING PROHIBITED MATERIALS/COMPONENTS CONTAINING LEAD, MERCURY, CADMIUM, HEXAVALENT CHROMIUM, POLYBROMINATED BIPHENYLS (PBB) AND POLYBROMINATED DIPHENYL ETHERS (PBDE)

2. MECHANICAL SPECIFICATIONS

- | | | |
|-----------------------|-------|------------------------------|
| (1) NUMBER OF DOTS | ----- | 128W * 64H DOTS |
| (2) MODULE SIZE | ----- | 64.0W * 52.0H * 5.9D(max) mm |
| (3) VIEWING AREA | ----- | 57W * 30H mm |
| (4) ACTIVE AREA | ----- | 53.75W * 26.87H mm |
| (5) DOT SIZE | ----- | 0.41W * 0.41H mm |
| (6) DOT PITCH | ----- | 0.42W * 0.42H mm |
| (7) LCD TYPE * | | |
| (8) DRIVING METHOD | ----- | 1 / 65 DUTY MULTIPLEX DRIVE |
| (9) VIEWING DIRECTION | ----- | 6 O'CLOCK |
| (10) BACK LIGHT | ----- | LED , COLOR : YELLOW-GREEN |

* PLEASE REFER TO NUMBERING SYSTEM .

3. ABSOLUTE MAXIMUM RATINGS

3.1 ELECTRICAL ABSOLUTE MAXIMUM RATINGS.

PARAMETER	SYMBOL	MIN.	MAX.	UNIT	REMARK
POWER SUPPLY FOR LOGIC	VDD – VSS	- 0.3	+ 4	V	
POWER SUPPLY FOR LCD DRIVE	VO – VSS	- 0.3	+15.0	V	
INPUT VOLTAGE	VI	- 0.3	VDD + 0.3	V	
STATIC ELECTRICITY	—	—	100	V	NOTE (1)

NOTE (1) : TEST METHOD AND CONDITIONS :
AFTER CHARGING UP 200 pF CAPACITOR BY STATED VOLTAGE ,
THE CAPACITOR IS CONNECTED WITH INTERFACE PINS OF THE
MODULE .

3.2 ENVIRONMENTAL ABSOLUTE MAXIMUM RATINGS .

I T E M	OPERATING		STORAGE		REMARK
	MIN.	MAX.	MIN.	MAX.	
AMBIENT TEMPERATURE	- 2 0 °C	7 0 °C	- 3 0 °C	8 0 °C	NOTE (1) , (3)
HUMIDITY	NOTE (2)		NOTE (2)		WITHOUT CONDENSATION
VIBRATION	—	4.9m/s ² (0.5G)	—	19.6m/s ² (2.0G)	
SHOCK	—	29.4 m/s ² (3G)	—	490.0m/s ² (50G)	XYZ DIRECTIONS
CORROSIVE GAS	NOT ACCEPTABLE		NOT ACCEPTABLE		

NOTE (1) : BACKGROUND COLOR CHANGES SLIGHTLY DEPENDING ON AMBIENT
TEMPERATURE THIS PHENOMENON IS REVERSIBLE .

NOTE (2) : Ta ≤ 60°C : 90%RH MAX.(96hr MAX.)

Ta > 60°C : ABSOLUTE HUMIDITY MUST BE LOWER THAN THE HUMIDITY
OF 90%RH AT 60°C.(96hr MAX.)

NOTE (3) : Ta AT -30°C : WILL BE < 48hr
80°C : WILL BE < 168hr

4. ELECTRICAL CHARACTERISTICS

Ta = 25 °C

PARAMETER	SYMBOL	CONDITION	MIN.	TYP.	MAX.	UNIT
POWER SUPPLY VOLTAGE FOR LOGIC (1)	VDD - VSS	—	3.0	3.3	3.6	V
BOOSTER OUTPUT VOLTAGE	VO - VSS	—	10.4	10.9	11.4	V
INPUT VOLTAGE NOTE (2)	VIH	H LEVEL	0.8VDD	—	VDD	V
	VIL	L LEVEL	VSS	—	0.2VDD	V
POWER SUPPLY CURRENT FOR LOGIC NOTE (3)	IDD	VDD-VSS	—	1.0	2.0	mA
OSCILLATOR FREQUENCY	fosc	INTERNAL	26.3	28.8	31.4	KHz
POWER SUPPLY FOR LED B/L	VLED-VLSS	IF = 58mA	—	5.0	—	V

NOTE (1) : REFER TO SECTION 11. POWER SUPPLY.

NOTE (2) : APPLIED TO TERMINALS /CS1 , /RES , /WR , /RD , A0 ,D0~D7

NOTE (3) : THIS DISPLAY PATTERN IS ALL ON OR OFF.

5. TIMING CHARACTERISTICS

5.1 READ/WRITE TIMING CHARACTERISTICS

PARAMETER	SYMBOL	MIN.	TYP.	MAX.	UNIT	CONDITION
ADDRESS HOLD TIME	T_{AH8}	0	—	—	ns	A0
ADDRESS SETUP TIME	T_{AS8}	0	—	—	ns	
SYSTEM CYCLE TIME	t_{CYC8}	240	—	—	ns	
CONTROL LOW PULSE WIDTH (WRITE)	t_{CCLW}	80	—	—	ns	/WR
CONTROL LOW PULSE WIDTH (READ)	t_{CCLR}	80	—	—	ns	/RD
CONTROL HIGH PULSE WIDTH (WRITE)	t_{CCHW}	80	—	—	ns	/WR
CONTROL HIGH PULSE WIDTH (READ)	t_{CCHR}	60	—	—	ns	/RD
DATA SETUP TIME	T_{DS8}	30	—	—	ns	D0-D7
DATA HOLD TIME	T_{DH8}	0	—	—	ns	
/RD ACCESS TIME	t_{ACC8}	—	—	70	ns	D0-D7, CL=100pF
OUTPUT DISABLE TIME	T_{CH8}	5	—	50	ns	

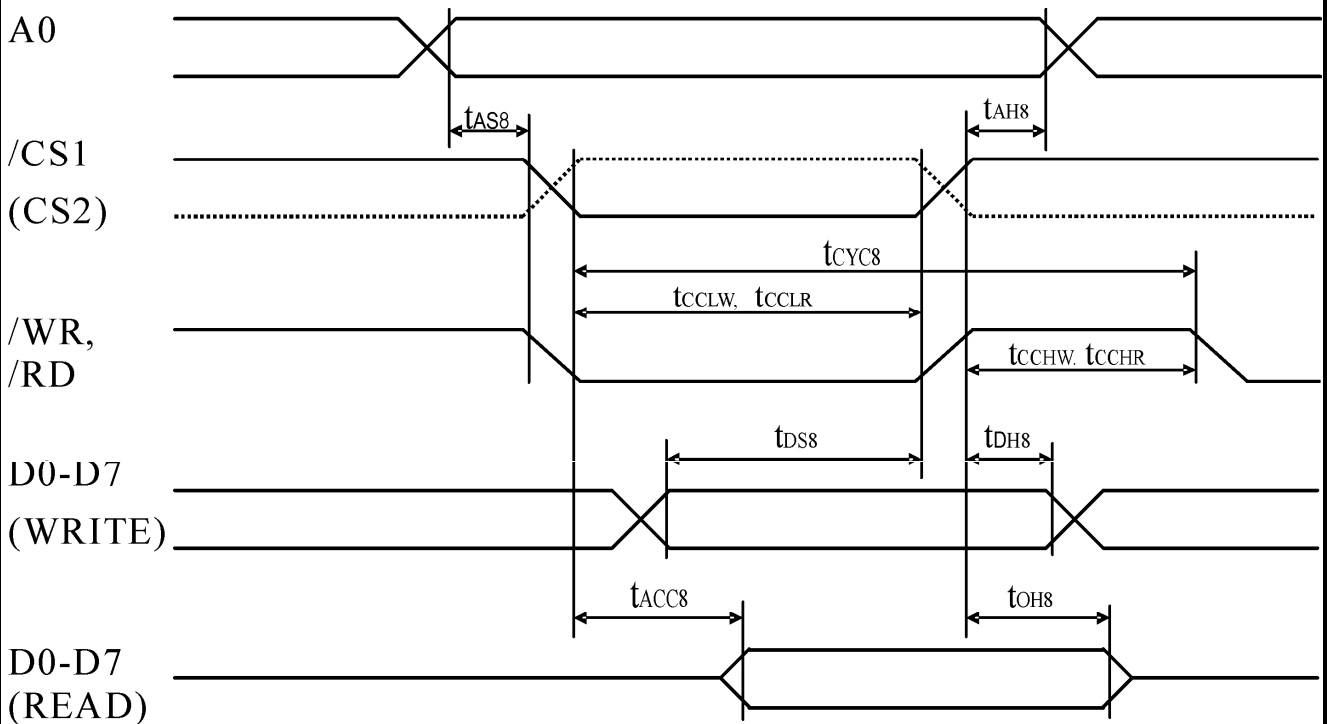

5.2 RESET TIMING

PARAMETER	SYMBOL	MIN.	TYP.	MAX.	UNIT	CONDITION
RESET TIME	t_R	—	—	1.0	μs	
RESET LOW PULSE WIDTH	t_{RW}	10	—	—	μs	/RES

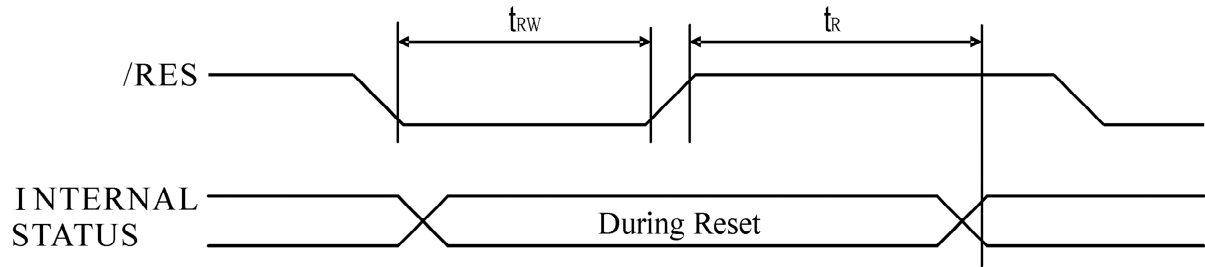

6. OPTICAL CHARACTERISTICS

Ta = 25 °C

I T E M		SYMBOL	CONDITION		MIN.	TYP.	MAX.	UNIT	NOTE
VIEWING ANGLE		θ_{y-}	K *	$\theta_{x}=0^{\circ}$	(36)	(41)	—	deg.	1
		θ_{y+}			(36)	(41)	—		
		θ_{x-}		$\theta_{y}=0^{\circ}$	(33)	(38)	—		
		θ_{x+}			(33)	(38)	—		
CONTRAST RATIO	STN	K	$\theta_{y}=10^{\circ}, \theta_{x}=0^{\circ}$		3	4.5	—	—	1
	FSTN				4	6	—	—	1
RESPONSE TIME	tr (rise)	$\theta_{y}=10^{\circ}$ $\theta_{x}=0^{\circ}$	Ta=-20°C		—	3450	4485	ms	1
			Ta=25°C			200	260		
			Ta=70°C			90	117		
	tf (fall)		Ta=-20°C		—	2060	2676		
			Ta=25°C			130	169		
			Ta=70°C			75	98		
THE BRIGHTNESS OF MODULE	L	VLED-VLSS		3	4	—	cd/m ²	1, 3	
		=5.0V		4.5	6	—		1, 2	

K* =STN : K≥1.5 ,FSTN : K≥2.0

NOTE (1) : PLEASE REFER TO :

CUSTOMER ACCEPTANCE STANDARD SPECIFICATIONS. (EU – 002B)

NOTE (2) : POLARIZER MODE : TRANSMISSIVE

NOTE (3) : POLARIZER MODE : TRANSFLECTIVE

MODEL NO. 13BA2 (LED TYPES)	VERSION 2	PAGE 7
--------------------------------	--------------	-----------

7. OUTLINE DIMENSIONS

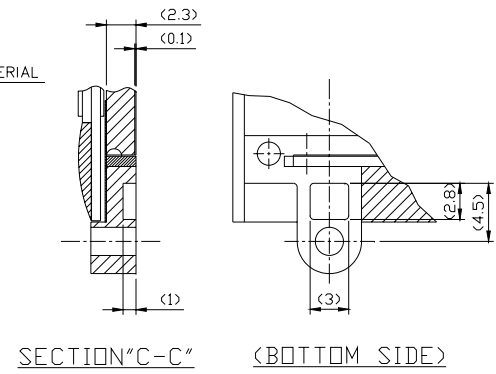
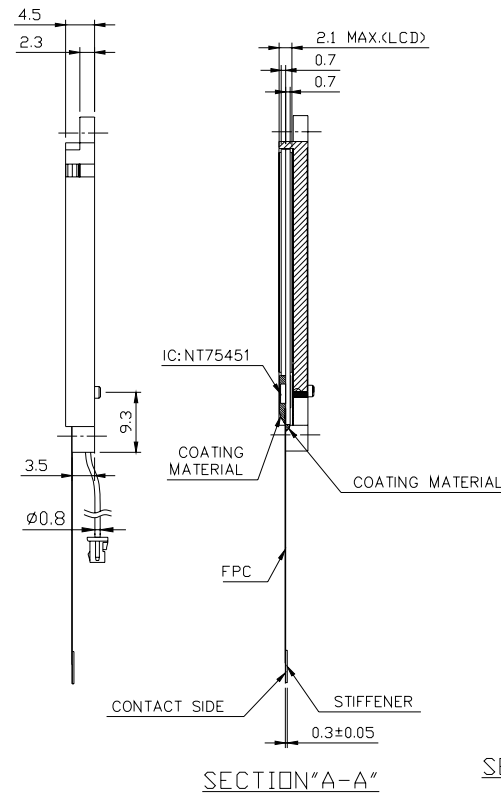
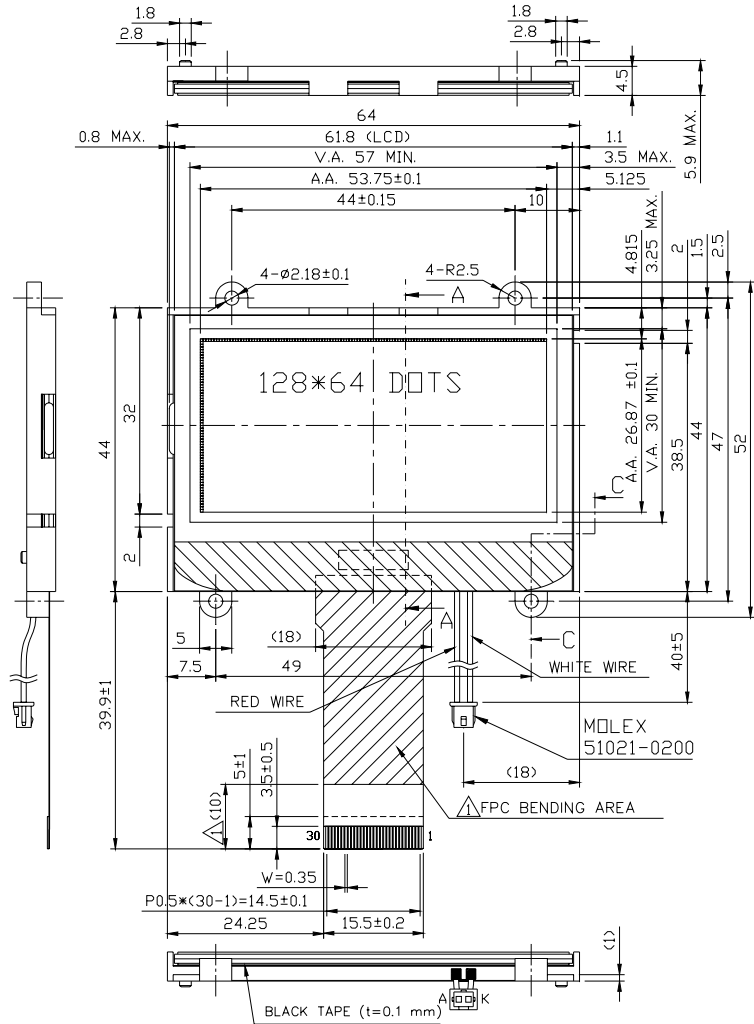

UNIT : mm
SCALE : NTS
NOT SPECIFIED TOLERANCE IS ± 0.5

8. DETAIL DRAWING OF DOT MATRIX

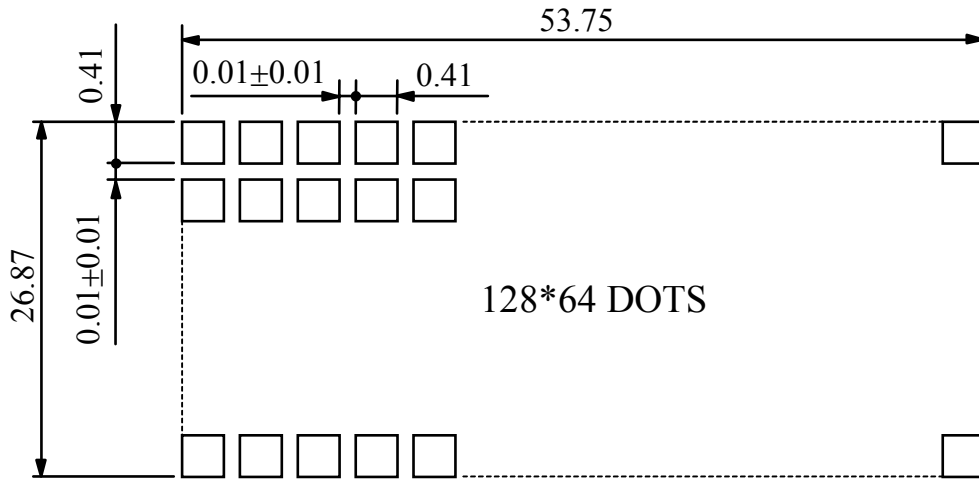

UNIT : mm
SCALE : NTS
NOT SPECIFIED TOLERANCE IS ± 0.1

9. BLOCK DIAGRAM

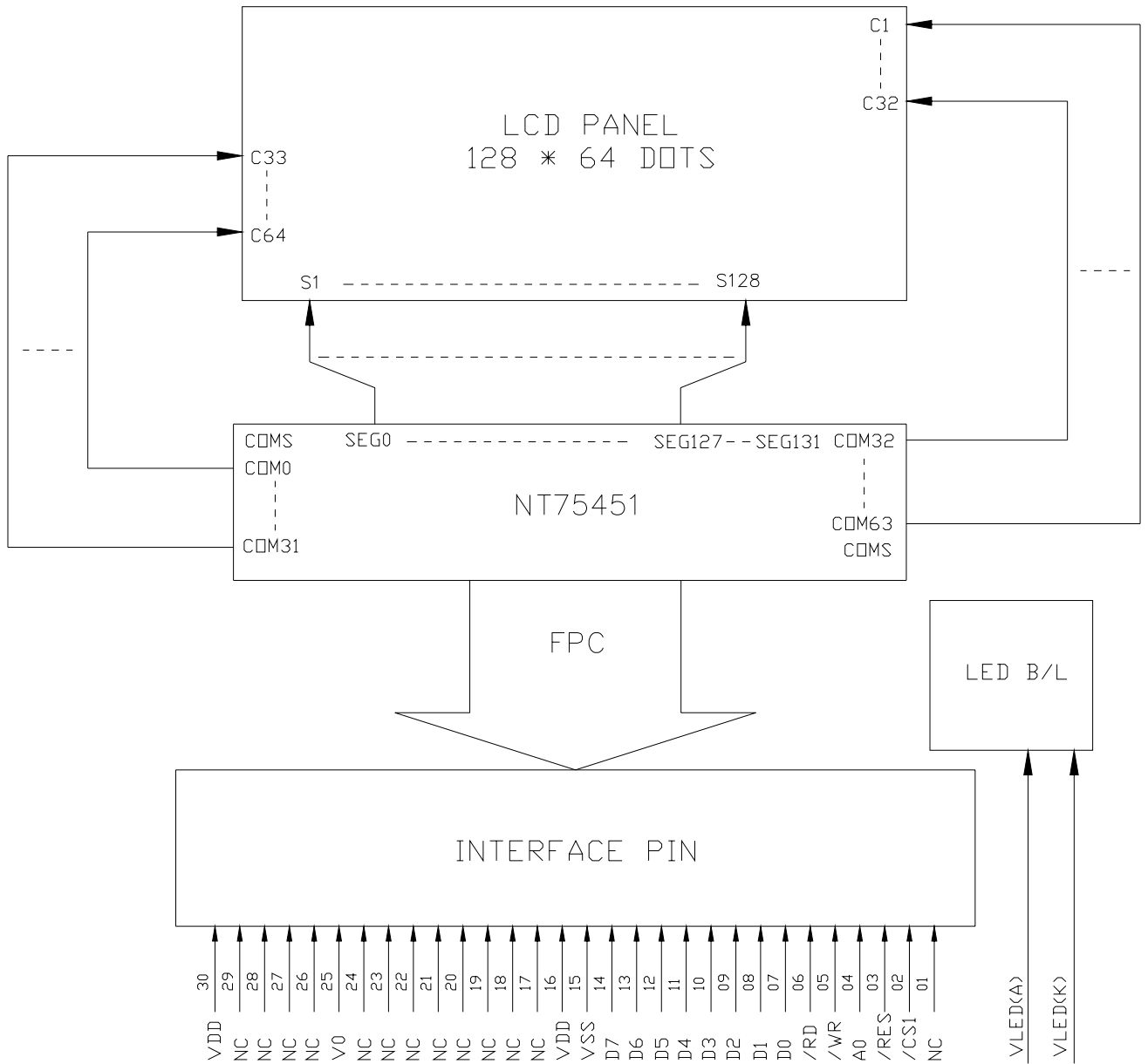

10. INTERFACE SIGNALS

PIN NO.	SYMBOL	LEVEL	FUNCTION
1	NC	—	NO CONNECTION (FOR OTP-PWR)
2	/CS1	H/L	CHIP SELECT INPUTS
3	/RES	—	HARDWARE RESET INPUT
4	A0	—	REGISTER SELECT INPUTS A0 = "H" DB0~DB7 ARE DISPLAY DATA A0 = "L" DB0~DB7 ARE CONTROL DATA
5	/WR	H/L	READ/WRITE EXECUTION CONTROL PIN WHEN 80 TYPE MPU IS USED WRITE ENABLE CLOCK INPUT PIN
6	/RD	H/L	READ/WRITE EXECUTION CONTROL PIN WHEN 80 TYPE MPU IS USED READ ENABLE CLOCK INPUT PIN
7	D0	H/L	DATA BUS LINE
8	D1		
9	D2		
10	D3		
11	D4		
12	D5		
13	D6		
14	D7		
15	VSS	—	GROUND
16	VDD	—	POWER SUPPLY FOR LOGIC(3.3V)
17	NC	—	NO CONNECTION
18	NC	—	
19	NC	—	
20	NC	—	
21	NC	—	
22	NC	—	
23	NC	—	
24	NC	—	
25	V0	—	LCD DRIVER SUPPLY VOLTAGES
26	NC	—	NO CONNECTION
27	NC	—	
28	NC	—	
29	NC	—	
30	VDD	—	POWER SUPPLY FOR LOGIC(3.3V)
—	VLED(A)	—	POWER SUPPLY FOR LED BACK-LIGHT (RED WIRE)
—	VLSS(K)	—	POWER SUPPLY FOR LED BACK-LIGHT (WHITE WIRE)

1 1 . POWER SUPPLY

1 1.1 POWER SUPPLY FOR LCM

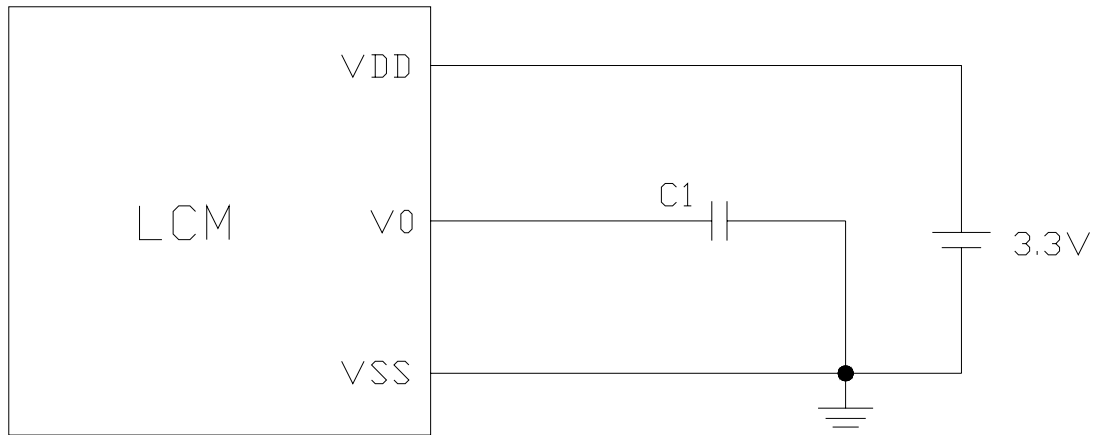

NOTE :

C1 : 0.47 μ f – 1.0 μ f

V0 : $(1+R_a/R_b) * (1 - \frac{63-\alpha}{162}) * 1.4$

INTERNAL REAGUATOR RESISTORS

1 1.2 POWER SUPPLY FOR LED BACK-LIGHT

