

December 2001

**Features**

- Logic Level Gate Drive
- Internal Voltage Clamp
- ESD Gate Protection
- $T_J = 175^{\circ}\text{C}$
- Ignition Energy Capable

**Description**

This N-Channel IGBT is a MOS gated, logic level device which is intended to be used as an ignition coil driver in automotive ignition circuits. Unique features include an active voltage clamp between the collector and the gate which provides Self Clamped Inductive Switching (SCIS) capability in ignition circuits. Internal diodes provide ESD protection for the logic level gate. Both a series resistor and a shunt resistor are provided in the gate circuit.

**PACKAGING AVAILABILITY**

PART NUMBER	PACKAGE	BRAND
HGTP14N36G3VL	TO-220AB	14N36GVL
HGT1S14N36G3VL	TO-262AA	14N36GVL
HGT1S14N36G3VLS	TO-263AB	14N36GVL

NOTE: When ordering, use the entire part number. Add the suffix 9A to obtain the TO-263AB variant in the tape and reel, i.e., HGT1S14N36G3VLS9A.

The development type number for this device is TA49021.

**Packages**

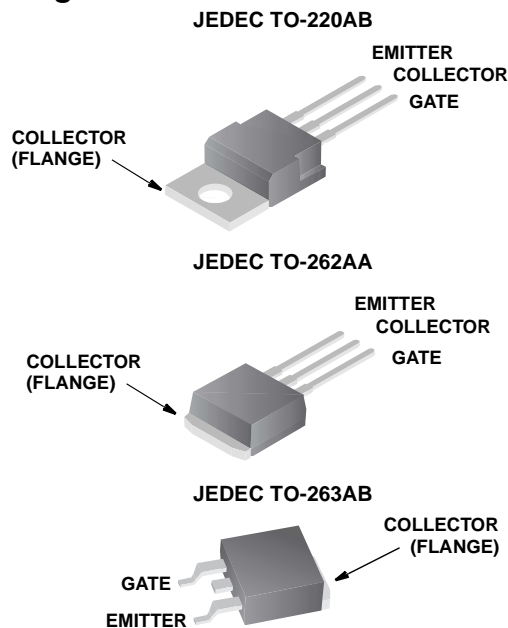

**Terminal Diagram**

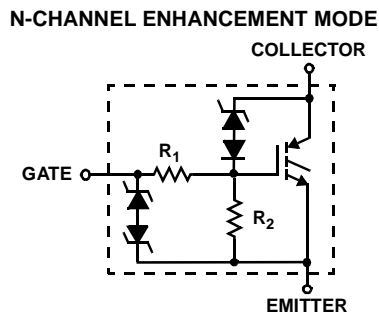

**Absolute Maximum Ratings**  $T_C = +25^{\circ}\text{C}$ , Unless Otherwise Specified

	HGTP14N36G3VL, HGT1S14N36G3VL, HGT1S14N36G3VLS	UNITS
Collector-Emitter Bkdn Voltage at 10mA	390	V
Emitter-Collector Bkdn Voltage at 10mA	24	V
Collector Current Continuous at $V_{GE} = 5V, T_C = +25^{\circ}\text{C}$	18	A
at $V_{GE} = 5V, T_C = +100^{\circ}\text{C}$	14	A
Gate-Emitter Voltage (Note)	$\pm 10$	V
Inductive Switching Current at $L = 2.3\text{mH}, T_C = +25^{\circ}\text{C}$	17	A
at $L = 2.3\text{mH}, T_C = +175^{\circ}\text{C}$	12	A
Collector to Emitter Avalanche Energy at $L = 2.3\text{mH}, T_C = +25^{\circ}\text{C}$	332	mJ
Power Dissipation Total at $T_C = +25^{\circ}\text{C}$	100	W
Power Dissipation Derating $T_C > +25^{\circ}\text{C}$	0.67	W/ $^{\circ}\text{C}$
Operating and Storage Junction Temperature Range	-40 to +175	$^{\circ}\text{C}$
Maximum Lead Temperature for Soldering	260	$^{\circ}\text{C}$
Electrostatic Voltage at 100pF, 1500 $\Omega$	6	KV

NOTE: May be exceeded if  $I_{GEM}$  is limited to 10mA.

# Specifications HGTP14N36G3VL, HGT1S14N36G3VL, HGT1S14N36G3VLS

## Electrical Specifications $T_C = +25^\circ\text{C}$ , Unless Otherwise Specified

PARAMETERS	SYMBOL	TEST CONDITIONS	LIMITS			UNITS	
			MIN	TYP	MAX		
Collector-Emitter Breakdown Voltage	$BV_{\text{CER}}$	$I_C = 10\text{mA}$ , $V_{\text{GE}} = 0\text{V}$ $R_{\text{GE}} = 1\text{k}\Omega$	$T_C = +175^\circ\text{C}$	320	355	400	V
			$T_C = +25^\circ\text{C}$	330	360	390	V
			$T_C = -40^\circ\text{C}$	320	350	385	V
Gate-Emitter Plateau Voltage	$V_{\text{GEP}}$	$I_C = 7\text{A}$ , $V_{\text{CE}} = 12\text{V}$	$T_C = +25^\circ\text{C}$		2.7	-	V
Gate Charge	$Q_{\text{G(ON)}}$	$I_C = 7\text{A}$ , $V_{\text{CE}} = 12\text{V}$	$T_C = +25^\circ\text{C}$		24	-	nC
Collector-Emitter Clamp Breakdown Voltage	$BV_{\text{CE(CL)}}$	$I_C = 7\text{A}$ $R_G = 1000\Omega$	$T_C = +175^\circ\text{C}$	350	380	410	V
Emitter-Collector Breakdown Voltage	$BV_{\text{ECS}}$	$I_C = 10\text{mA}$	$T_C = +25^\circ\text{C}$	4	28	-	V
Collector-Emitter Leakage Current	$I_{\text{CER}}$	$V_{\text{CE}} = 250\text{V}$ $R_{\text{GE}} = 1\text{k}\Omega$	$T_C = +25^\circ\text{C}$		-	25	$\mu\text{A}$
			$T_C = +175^\circ\text{C}$	-	-	250	$\mu\text{A}$
Collector-Emitter Saturation Voltage	$V_{\text{CE(SAT)}}$	$I_C = 7\text{A}$ $V_{\text{GE}} = 4.5\text{V}$	$T_C = +25^\circ\text{C}$	-	1.25	1.45	V
			$T_C = +175^\circ\text{C}$	-	1.15	1.6	V
		$I_C = 14\text{A}$ $V_{\text{GE}} = 5\text{V}$	$T_C = +25^\circ\text{C}$		1.6	2.2	V
			$T_C = +175^\circ\text{C}$		1.7	2.9	V
Gate-Emitter Threshold Voltage	$V_{\text{GE(TH)}}$	$I_C = 1\text{mA}$ $V_{\text{CE}} = V_{\text{GE}}$	$T_C = +25^\circ\text{C}$	1.3	1.8	2.2	V
Gate Series Resistance	$R_1$		$T_C = +25^\circ\text{C}$		75	-	$\Omega$
Gate-Emitter Resistance	$R_2$		$T_C = +25^\circ\text{C}$	102	03	0	k $\Omega$
Gate-Emitter Leakage Current	$I_{\text{GES}}$	$V_{\text{GE}} = \pm 10\text{V}$		$\pm 330$	$\pm 500$	$\pm 1000$	$\mu\text{A}$
Gate-Emitter Breakdown Voltage	$BV_{\text{GES}}$	$I_{\text{GES}} = \pm 2\text{mA}$		$\pm 12$	$\pm 14$	-	V
Current Turn-Off Time-Inductive Load	$t_{\text{D(OFF)I}} + t_{\text{F(OFF)I}}$	$I_C = 7\text{A}$ , $R_L = 28\Omega$ $R_G = 25\Omega$ , $L = 550\mu\text{H}$ , $V_{\text{CL}} = 300\text{V}$ , $V_{\text{GE}} = 5\text{V}$ , $T_C = +175^\circ\text{C}$		-7		-	$\mu\text{s}$
Inductive Use Test	$I_{\text{SCIS}}$	$L = 2.3\text{mH}$ , $V_G = 5\text{V}$ ,	$T_C = +175^\circ\text{C}$	2	-	-	A
			$T_C = +25^\circ\text{C}$	7	-	-	A
Thermal Resistance	$R_{\theta\text{JC}}$			--		1.5	$^\circ\text{C/W}$

Typical Performance Curves

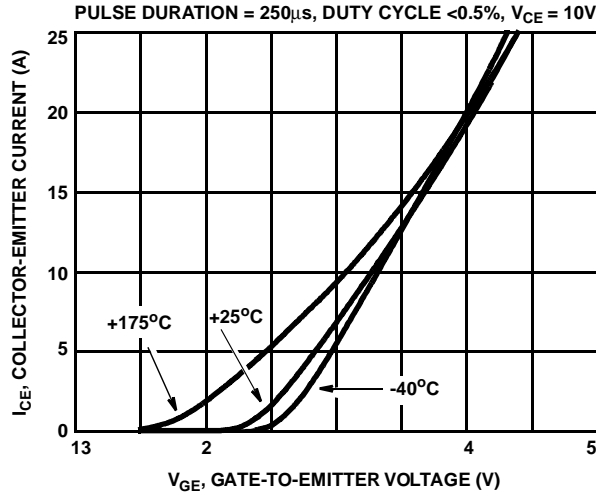

FIGURE 1. TRANSFER CHARACTERISTICS

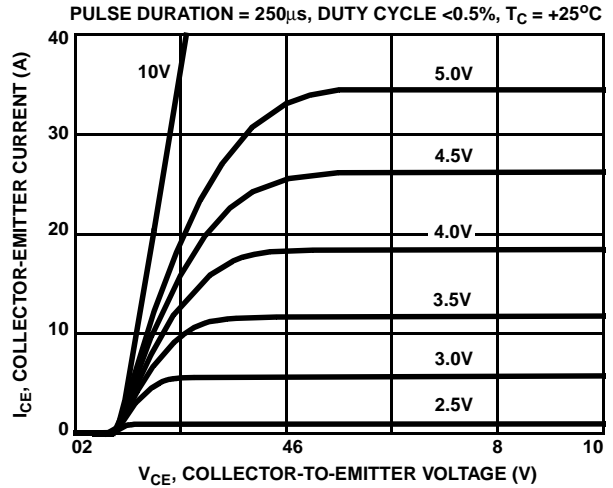

FIGURE 2. SATURATION CHARACTERISTICS

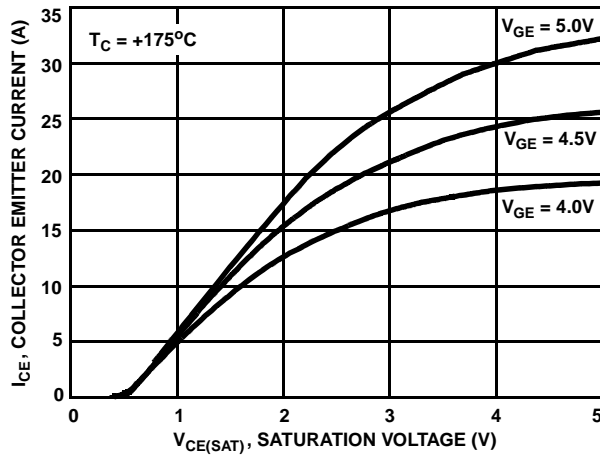

FIGURE 3. COLLECTOR-EMITTER CURRENT AS A FUNCTION OF SATURATION VOLTAGE

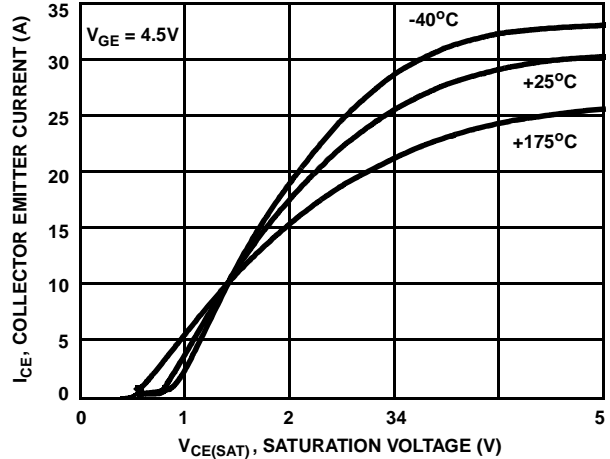

FIGURE 4. COLLECTOR-EMITTER CURRENT AS A FUNCTION OF SATURATION VOLTAGE

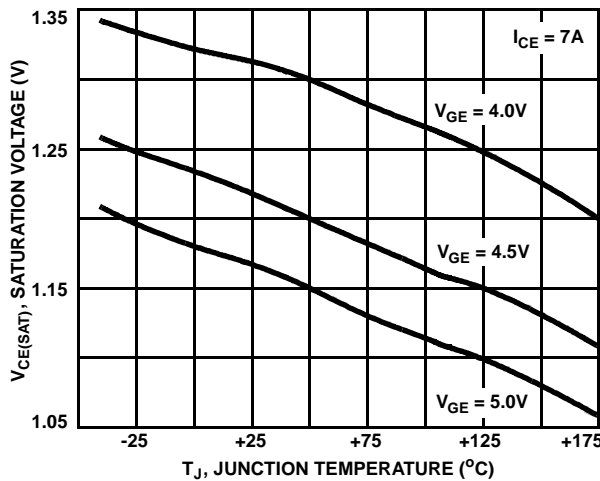

FIGURE 5. SATURATION VOLTAGE AS A FUNCTION OF JUNCTION TEMPERATURE

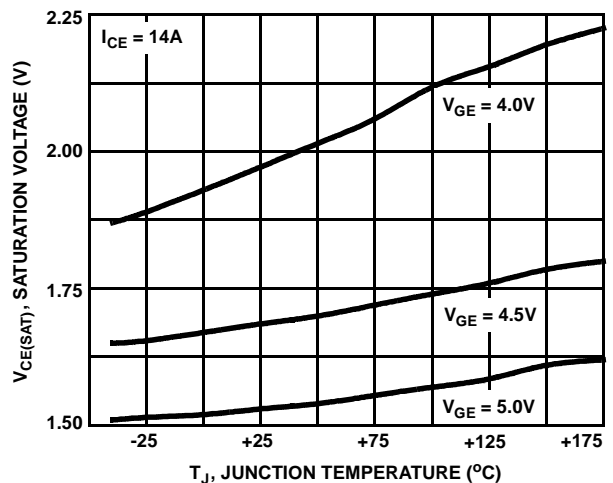

FIGURE 6. SATURATION VOLTAGE AS A FUNCTION OF JUNCTION TEMPERATURE

Typical Performance Curves (Continued)

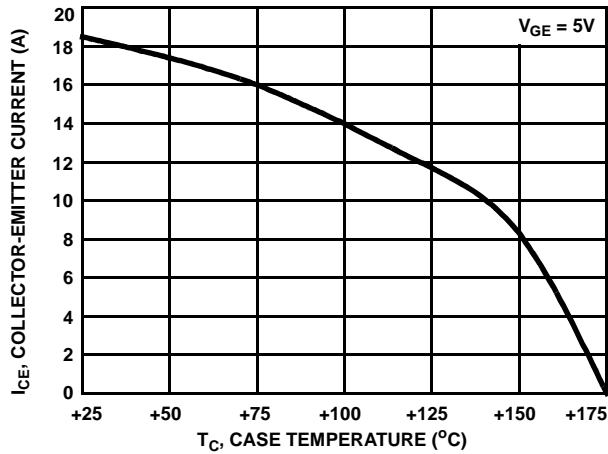

FIGURE 7. COLLECTOR-EMITTER CURRENT AS A FUNCTION OF CASE TEMPERATURE

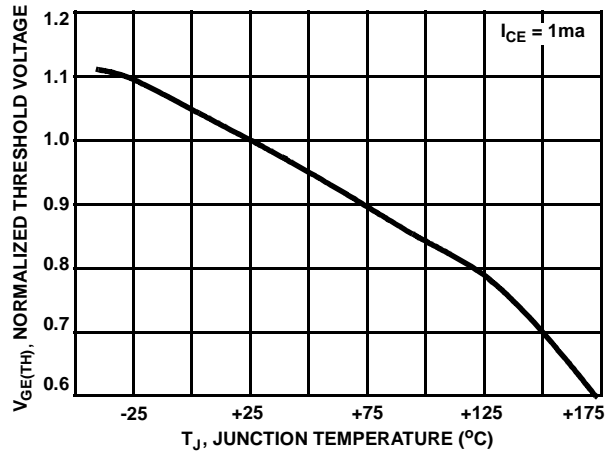

FIGURE 8. NORMALIZED THRESHOLD VOLTAGE AS A FUNCTION OF JUNCTION TEMPERATURE

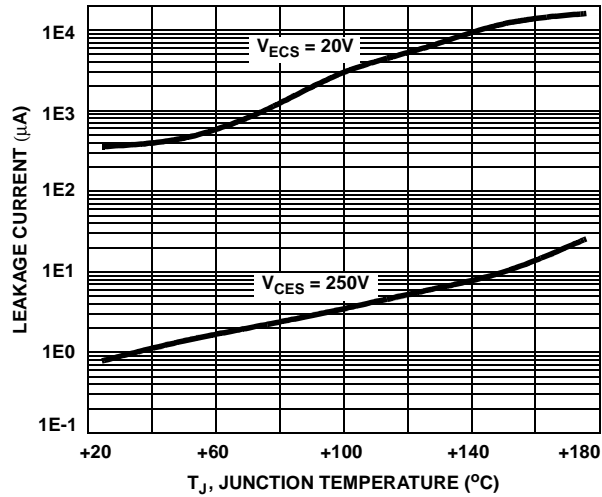

FIGURE 9. LEAKAGE CURRENT AS A FUNCTION OF JUNCTION TEMPERATURE

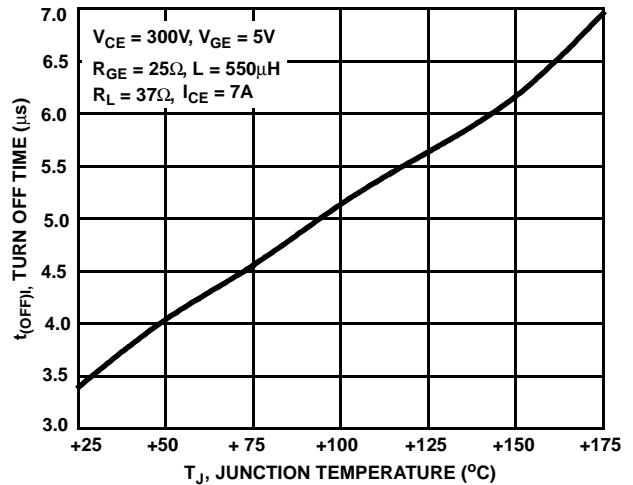

FIGURE 10. TURN-OFF TIME AS A FUNCTION OF JUNCTION TEMPERATURE

Typical Performance Curves (Continued)

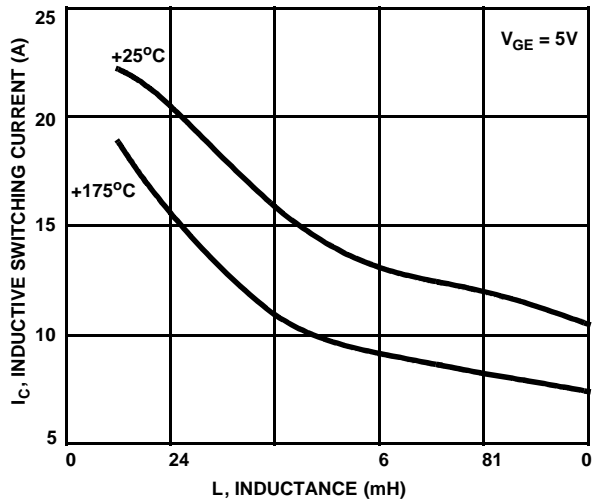

FIGURE 11. SELF CLAMPED INDUCTIVE SWITCHING CURRENT AS A FUNCTION OF INDUCTANCE

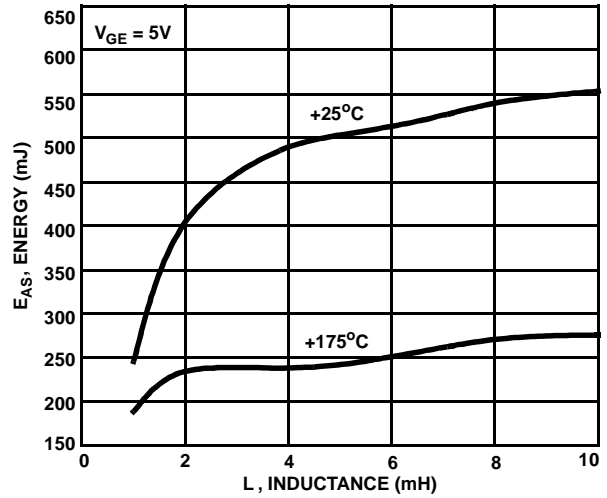

FIGURE 12. SELF CLAMPED INDUCTIVE SWITCHING ENERGY AS A FUNCTION OF INDUCTANCE

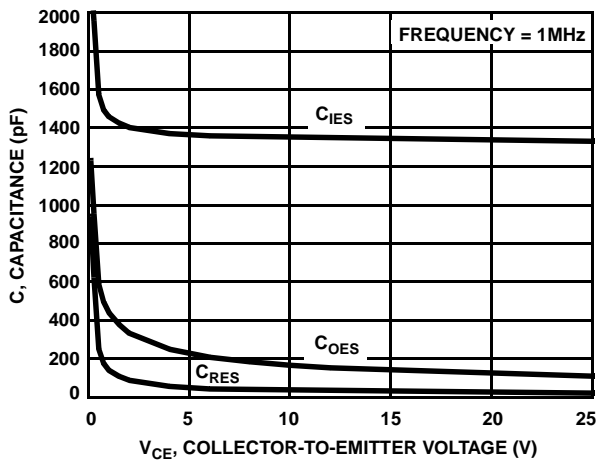

FIGURE 13. CAPACITANCE AS A FUNCTION OF COLLECTOR-EMITTER VOLTAGE

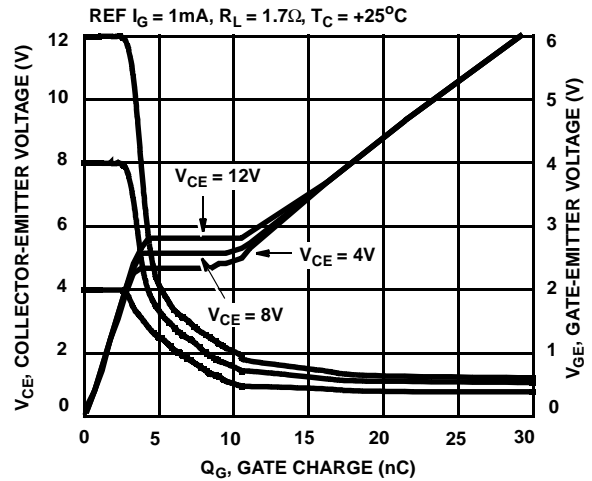

FIGURE 14. GATE CHARGE WAVEFORMS

## Typical Performance Curves (Continued)

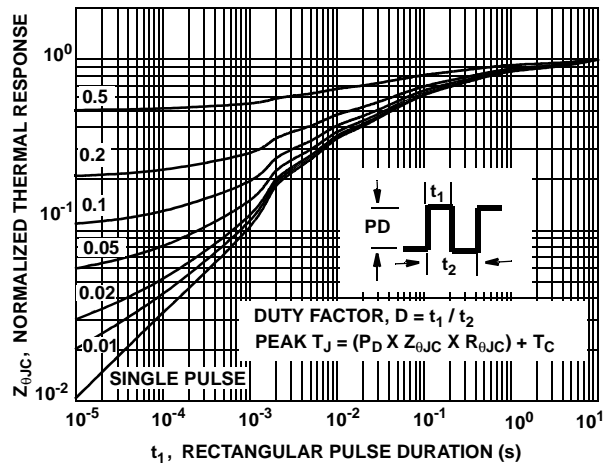

FIGURE 15. NORMALIZED TRANSIENT THERMAL IMPEDANCE, JUNCTION TO CASE

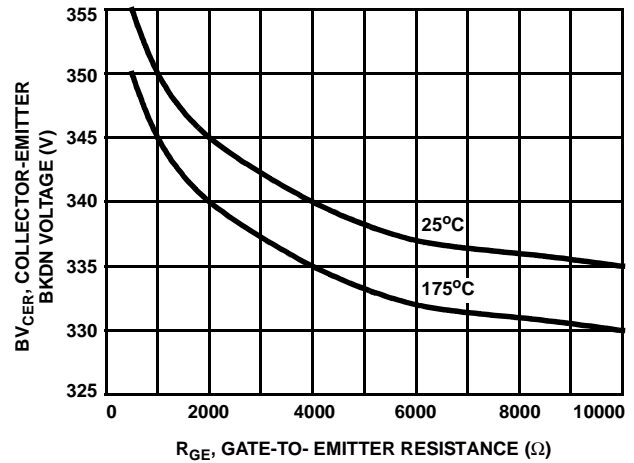

FIGURE 16. BREAKDOWN VOLTAGE AS A FUNCTION OF GATE-EMITTER RESISTANCE

## Test Circuits

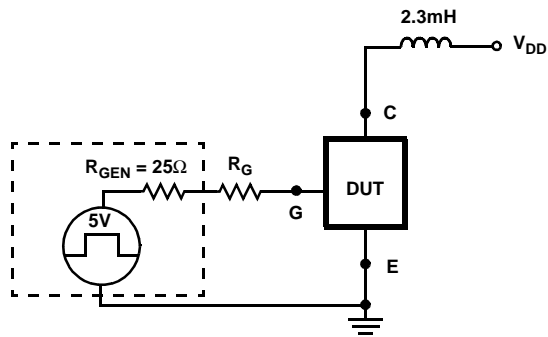

FIGURE 17. SELF CLAMPED INDUCTIVE SWITCHING CURRENT TEST CIRCUIT

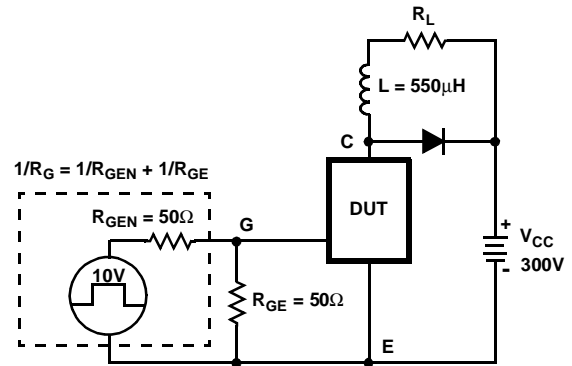

FIGURE 18. CLAMPED INDUCTIVE SWITCHING TIME TEST CIRCUIT

**Handling Precautions for IGBT's**

Insulated Gate Bipolar Transistors are susceptible to gate-insulation damage by the electrostatic discharge of energy through the devices. When handling these devices, care should be exercised to assure that the static charge built in the handler's body capacitance is not discharged through the device. With proper handling and application procedures, however, IGBT's are currently being extensively used in production by numerous equipment manufacturers in military, industrial and consumer applications, with virtually no damage problems due to electrostatic discharge. IGBT's can be handled safely if the following basic precautions are taken:

1. Prior to assembly into a circuit, all leads should be kept

shorted together either by the use of metal shorting springs or by the insertion into conductive material such as †"ECCOSORB LD26" or equivalent.

2. When devices are removed by hand from their carriers, the hand being used should be grounded by any suitable means - for example, with a metallic wristband.
3. Tips of soldering irons should be grounded.
4. Devices should never be inserted into or removed from circuits with power on.
5. **Gate Voltage Rating** -The gate-voltage rating of  $V_{GEM}$  may be exceeded if  $I_{GEM}$  is limited to 10mA.

† Trademark Emerson and Cumming, Inc

**FAIRCHILD CORPORATION IGBT PRODUCT IS COVERED BY ONE OR MORE OF THE FOLLOWING U.S. PATENTS:**

4,364,073	4,417,385	4,430,792	4,443,931	4,466,176	4,516,143	4,532,534	4,567,641
4,587,713	4,598,461	4,605,948	4,618,872	4,620,211	4,631,564	4,639,754	4,639,762
4,641,162	4,644,637	4,682,195	4,684,413	4,694,313	4,717,679	4,743,952	4,783,690
4,794,432	4,801,986	4,803,533	4,809,045	4,809,047	4,810,665	4,823,176	4,837,606
4,860,080	4,883,767	4,888,627	4,890,143	4,901,127	4,904,609	4,933,740	4,963,951
4,969,027							

## TRADEMARKS

The following are registered and unregistered trademarks Fairchild Semiconductor owns or is authorized to use and is not intended to be an exhaustive list of all such trademarks.

ACE <sub>x</sub> <sup>TM</sup>	FAST <sup>®</sup>	OPTOLOGIC <sup>TM</sup>	SMART START <sup>TM</sup>	VCX <sup>TM</sup>
Bottomless <sup>TM</sup>	FAST <sub>r</sub> <sup>TM</sup>	OPTOPLANAR <sup>TM</sup>	STAR*POWER <sup>TM</sup>	
CoolFET <sup>TM</sup>	FRFET <sup>TM</sup>	PACMAN <sup>TM</sup>	Stealth <sup>TM</sup>	
CROSSVOLT <sup>TM</sup>	GlobalOptoisolator <sup>TM</sup>	POPT <sup>TM</sup>	SuperSOT <sup>TM</sup> -3	
DenseTrench <sup>TM</sup>	GTO <sup>TM</sup>	Power247 <sup>TM</sup>	SuperSOT <sup>TM</sup> -6	
DOMET <sup>TM</sup>	HiSeC <sup>TM</sup>	PowerTrench <sup>®</sup>	SuperSOT <sup>TM</sup> -8	
EcoSPARK <sup>TM</sup>	ISOPLANAR <sup>TM</sup>	QFET <sup>TM</sup>	SyncFET <sup>TM</sup>	
E <sup>2</sup> CMOS <sup>TM</sup>	LittleFET <sup>TM</sup>	QST <sup>TM</sup>	TinyLogic <sup>TM</sup>	
EnSigna <sup>TM</sup>	MicroFET <sup>TM</sup>	QT Optoelectronics <sup>TM</sup>	TruTranslation <sup>TM</sup>	
FACT <sup>TM</sup>	MicroPak <sup>TM</sup>	Quiet Series <sup>TM</sup>	UHC <sup>TM</sup>	
FACT Quiet Series <sup>TM</sup>	MICROWIRE <sup>TM</sup>	SILENT SWITCHER <sup>®</sup>	UltraFET <sup>®</sup>	

STAR\*POWER is used under license

## DISCLAIMER

FAIRCHILD SEMICONDUCTOR RESERVES THE RIGHT TO MAKE CHANGES WITHOUT FURTHER NOTICE TO ANY PRODUCTS HEREIN TO IMPROVE RELIABILITY, FUNCTION OR DESIGN. FAIRCHILD DOES NOT ASSUME ANY LIABILITY ARISING OUT OF THE APPLICATION OR USE OF ANY PRODUCT OR CIRCUIT DESCRIBED HEREIN; NEITHER DOES IT CONVEY ANY LICENSE UNDER ITS PATENT RIGHTS, NOR THE RIGHTS OF OTHERS.

## LIFE SUPPORT POLICY

FAIRCHILD'S PRODUCTS ARE NOT AUTHORIZED FOR USE AS CRITICAL COMPONENTS IN LIFE SUPPORT DEVICES OR SYSTEMS WITHOUT THE EXPRESS WRITTEN APPROVAL OF FAIRCHILD SEMICONDUCTOR CORPORATION  
As used herein:

1. Life support devices or systems are devices or systems which, (a) are intended for surgical implant into the body, or (b) support or sustain life, or (c) whose failure to perform when properly used in accordance with instructions for use provided in the labeling, can be reasonably expected to result in significant injury to the user.
2. A critical component is any component of a life support device or system whose failure to perform can be reasonably expected to cause the failure of the life support device or system, or to affect its safety or effectiveness.

## PRODUCT STATUS DEFINITIONS

### Definition of Terms

Datasheet Identification	Product Status	Definition
Advance Information	Formative or In Design	This datasheet contains the design specifications for product development. Specifications may change in any manner without notice.
Preliminary	First Production	This datasheet contains preliminary data, and supplementary data will be published at a later date. Fairchild Semiconductor reserves the right to make changes at any time without notice in order to improve design.
No Identification Needed	Full Production	This datasheet contains final specifications. Fairchild Semiconductor reserves the right to make changes at any time without notice in order to improve design.
Obsolete	Not In Production	This datasheet contains specifications on a product that has been discontinued by Fairchild semiconductor. The datasheet is printed for reference information only.