



15N65-MT

Power MOSFET

15A, 650V N-CHANNEL POWER MOSFET

DESCRIPTION

The UTC **15N65-MT** is an N-channel mode power MOSFET using UTC's advanced technology to provide customers with planar stripe and DMOS technology. This technology allows a minimum on-state resistance and superior switching performance. It also can withstand high energy pulse in the avalanche and commutation mode.

The UTC **15N65-MT** is generally applied in high efficiency switch mode power supplies.

FEATURES

- * $R_{DS(ON)} \leq 0.6 \Omega$ @ $V_{GS}=10V, I_D=7.5A$
- * High Switching Speed

SYMBOL

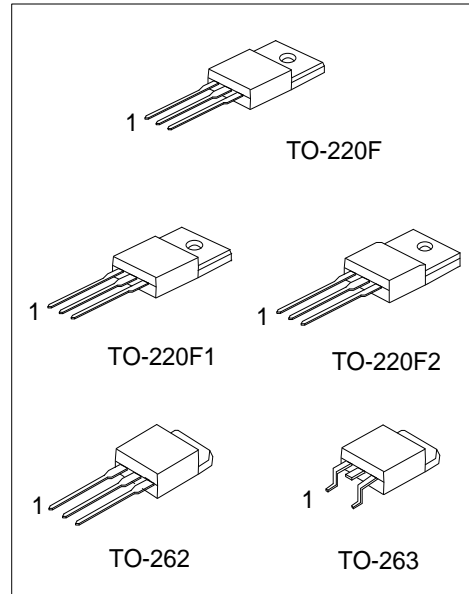
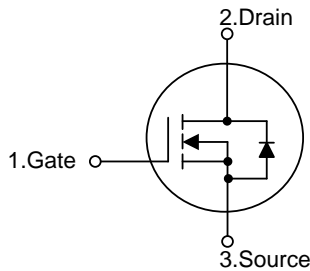

ORDERING INFORMATION

Ordering Number		Package	Pin Assignment			Packing
Lead Free	Halogen Free		1	2	3	
15N65L-TF1-T	15N65G-TF1-T	TO-220F1	G	D	S	Tube
15N65L-TF2-T	15N65G-TF2-T	TO-220F2	G	D	S	Tube
15N65L-TF3-T	15N65G-TF3-T	TO-220F	G	D	S	Tube
15N65L-T2Q-T	15N65G-T2Q-T	TO-262	G	D	S	Tube
15N65L-TQ2-T	15N65G-TQ2-T	TO-263	G	D	S	Tube
15N65L-TQ2-R	15N65G-TQ2-R	TO-263	G	D	S	Tape Reel

Note: Pin Assignment: G: Gate D: Drain S: Source

<p>15N65G-TF1-T</p> <p>(1) Packing Type (2) Package Type (3) Green Package</p>	<p>(1) T: Tube, R: Tape Reel (2) TF1: TO-220F1, TF2: TO-220F2, TF3: TO-220F, T2Q: TO-262, TQ2: TO-263 (3) G: Halogen Free and Lead Free, L: Lead Free</p>
--	---

MARKING

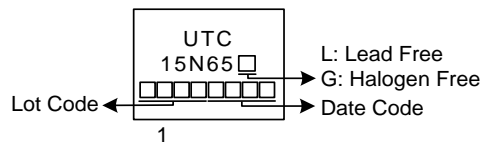

■ ABSOLUTE MAXIMUM RATINGS (T_C=25°C, unless otherwise specified.) (Note 5)

PARAMETER		SYMBOL	RATINGS	UNIT
Drain to Source Voltage		V _{DSS}	650	V
Gate-Source Voltage		V _{GSS}	±30	V
Drain Current	Continuous T _C =25°C	I _D	15	A
	Pulsed (Note 2)	I _{DM}	30	A
Avalanche Energy	Single Pulsed (Note 3)	E _{AS}	490	mJ
Peak Diode Recovery dv/dt (Note 4)		dv/dt	1.6	V/ns
Power Dissipation	TO-262/TO-263	P _D	240	W
	TO-220F/TO-220F1		41	W
	TO-220F2			
Junction Temperature		T _J	+150	°C
Storage Temperature		T _{STG}	-55 ~ +150	°C

Notes: 1. Absolute maximum ratings are those values beyond which the device could be permanently damaged.

Absolute maximum ratings are stress ratings only and functional device operation is not implied.

2. Repetitive Rating; Pulse width limited by maximum junction temperature.
3. L=10mH, I_{AS}=9.9A, V_{DD}=50V, R_G=25Ω, Starting T_J=25°C
4. I_{SD}≤15A, di/dt≤200A/μs, V_{DD}≤BV_{DSS}, Starting T_J=25°C
5. Drain current limited by maximum junction temperature.

■ THERMAL DATA

PARAMETER		SYMBOL	RATINGS	UNIT
Junction to Ambient		θ _{JA}	62.5	°C/W
Junction to Case	TO-262/TO-263	θ _{JC}	0.52	°C/W
	TO-220F/TO-220F1		3	°C/W
	TO-220F2			

■ ELECTRICAL CHARACTERISTICS

PARAMETER	SYMBOL	TEST CONDITIONS	MIN	TYP	MAX	UNIT
OFF CHARACTERISTICS						
Drain-Source Breakdown Voltage	BV_{DSS}	$I_D=250\mu A, V_{GS}=0V, T_J=25^\circ C$	650			V
Drain-Source Leakage Current	I_{DSS}	$V_{DS}=650V, V_{GS}=0V$			10	μA
Gate- Source Leakage Current	Forward	$V_{GS}=+30V, V_{DS}=0V$ $V_{GS}=-30V, V_{DS}=0V$			+100	nA
	Reverse				-100	nA
ON CHARACTERISTICS						
Gate Threshold Voltage	$V_{GS(TH)}$	$V_{GS}=V_{DS}, I_D=250\mu A$	2.0		4.0	V
Static Drain-Source On-State Resistance	$R_{DS(ON)}$	$V_{GS}=10V, I_D=7.5A$		0.48	0.6	Ω
DYNAMIC PARAMETERS						
Input Capacitance	C_{ISS}	$V_{DS}=25V, V_{GS}=0V, f=1.0MHz$		2230		pF
Output Capacitance	C_{OSS}			225		pF
Reverse Transfer Capacitance	C_{RSS}			14		pF
SWITCHING PARAMETERS						
Total Gate Charge	Q_G	$V_{DS}=200V, V_{GS}=10V, I_D=15A$ (Note 1, 2)		45		nC
Gate to Source Charge	Q_{GS}			14		nC
Gate to Drain ("Miller") Charge	Q_{GD}			15		nC
Turn-ON Delay Time	$t_{D(ON)}$	$V_{DS}=200V, I_D=15A, R_G=25\Omega$ (Note 1, 2)		28		ns
Rise Time	t_R			24		ns
Turn-OFF Delay Time	$t_{D(OFF)}$			160		ns
Fall-Time	t_F			38		ns
SOURCE- DRAIN DIODE RATINGS AND CHARACTERISTICS						
Maximum Body-Diode Continuous Current	I_S				15	A
Maximum Body-Diode Pulsed Current	I_{SM}				30	A
Drain-Source Diode Forward Voltage	V_{SD}	$I_S=15A, V_{GS}=0V$			1.4	V
Body Diode Reverse Recovery Time	t_{rr}	$I_S=15A, V_{GS}=0V,$ $di_F/dt=100A/\mu s$		550		ns
Body Diode Reverse Recovery Charge	Q_{rr}				6.3	

Notes: 1. Pulse Test: Pulse width $\leq 300\mu s$; Duty Cycle $\leq 2\%$

2. Essentially Independent of Operating Temperature Typical Characteristics

■ TEST CIRCUITS AND WAVEFORMS

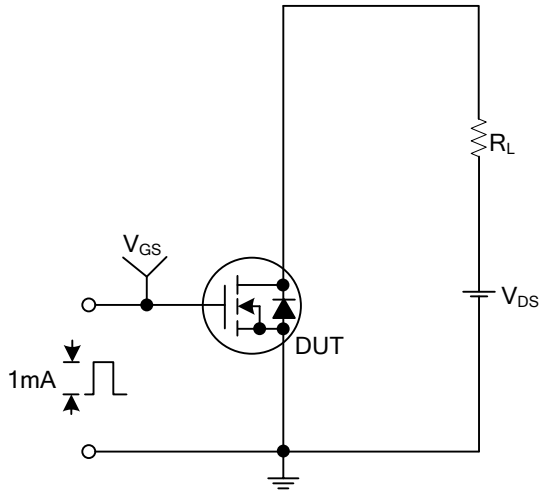

Gate Charge Test Circuit

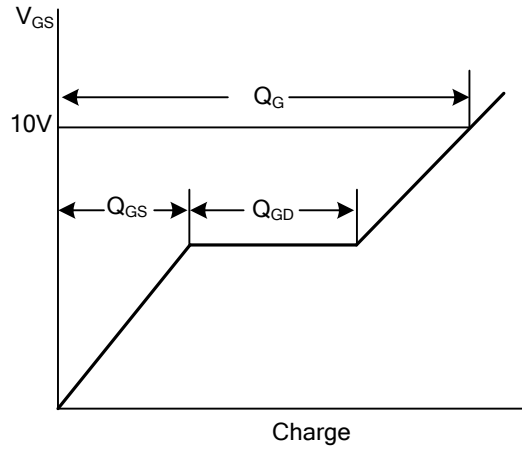

Gate Charge Waveforms

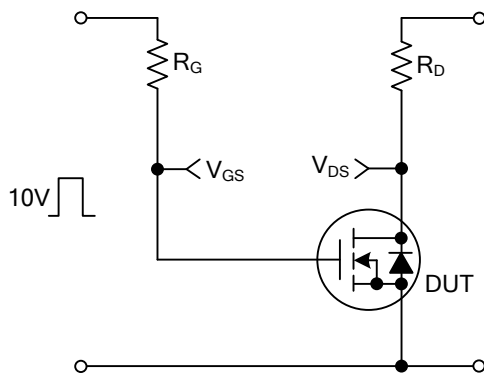

Resistive Switching Test Circuit

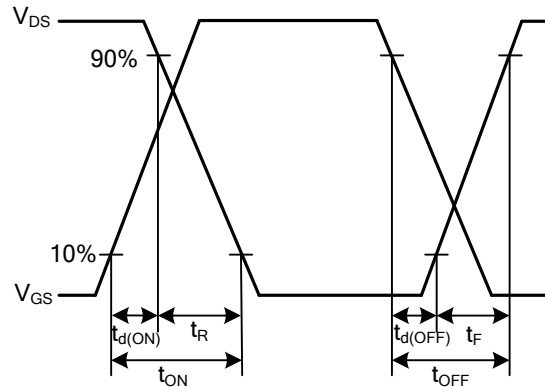

Resistive Switching Waveforms

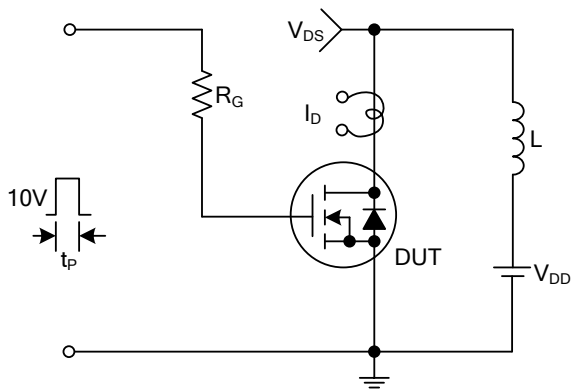

Unclamped Inductive Switching Test Circuit

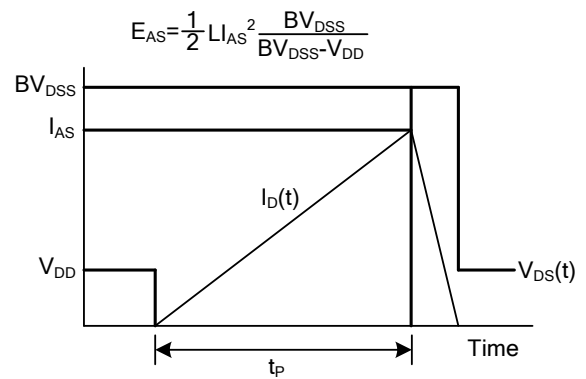

Unclamped Inductive Switching Waveforms

TEST CIRCUITS AND WAVEFORMS

Peak Diode Recovery dv/dt Test Circuit & Waveforms

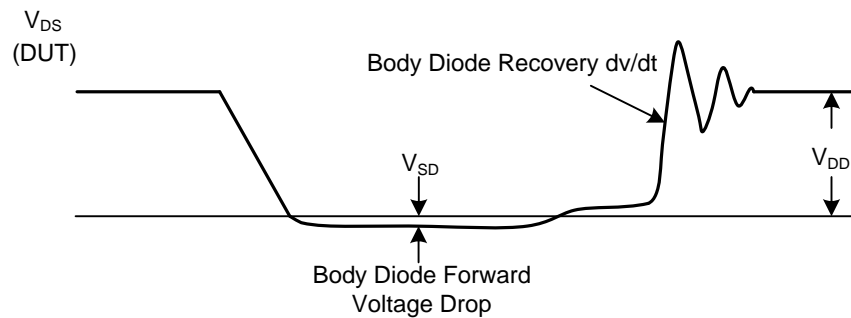
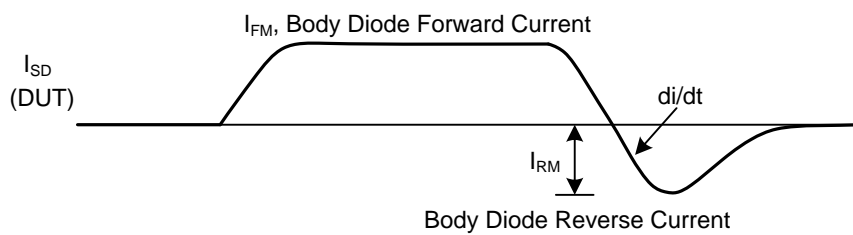
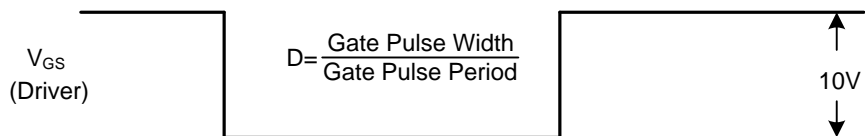
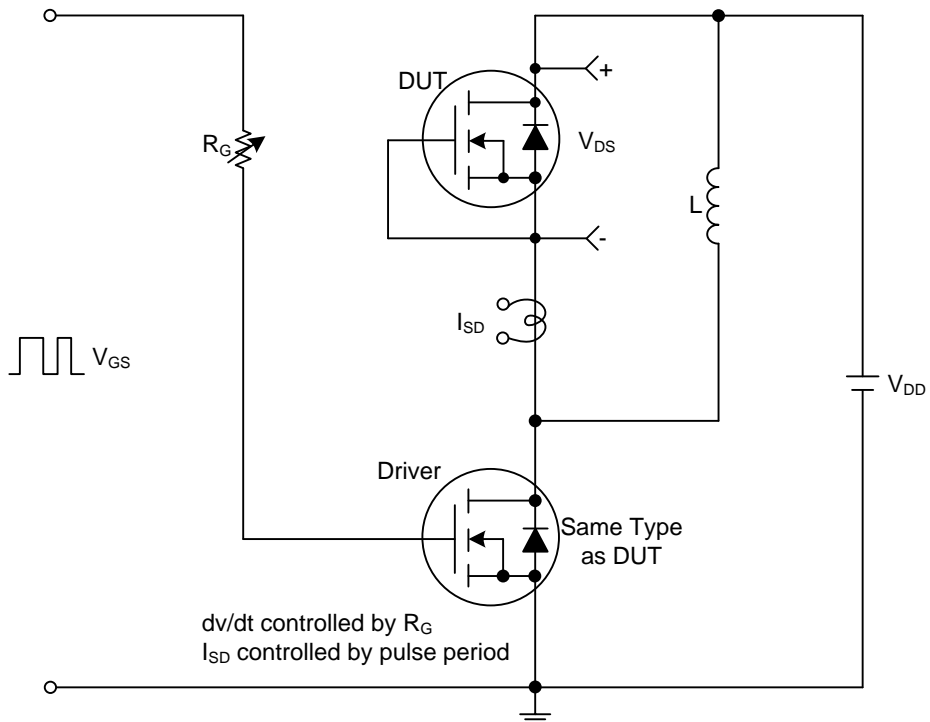

TYPICAL CHARACTERISTICS

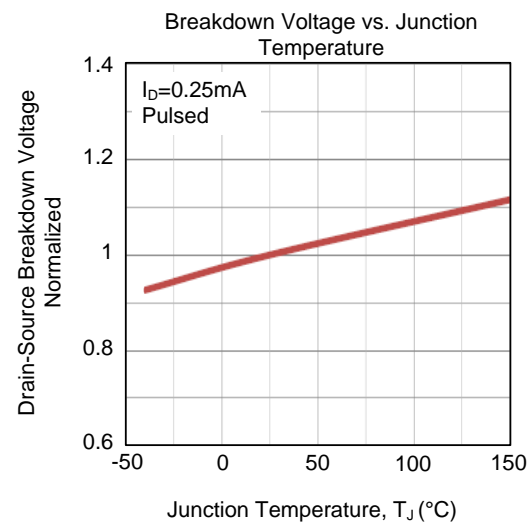
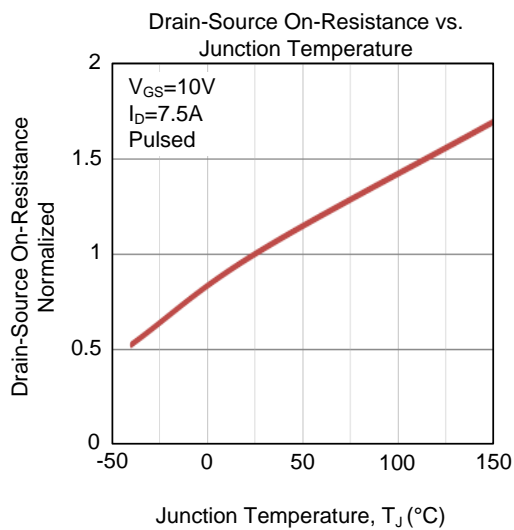
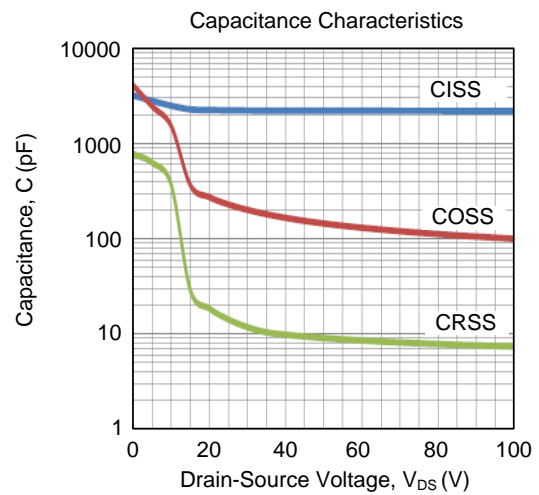
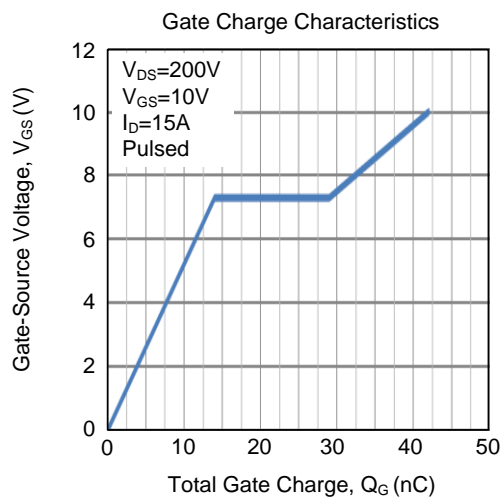
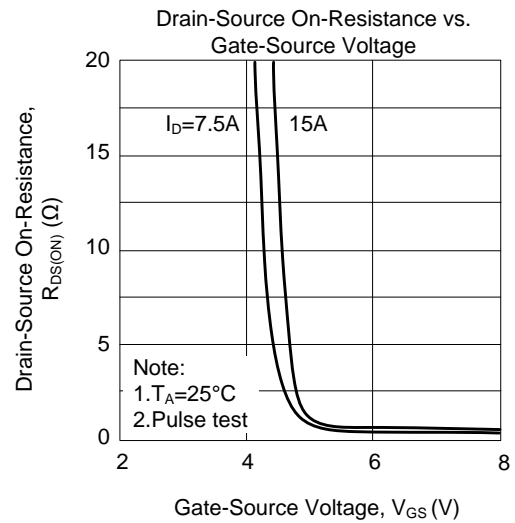
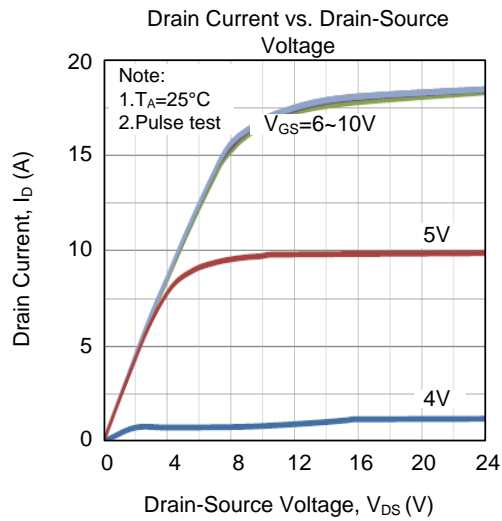

■ TYPICAL CHARACTERISTICS (Cont.)

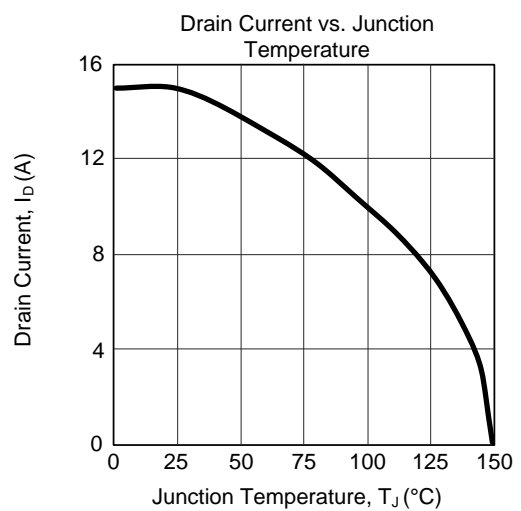
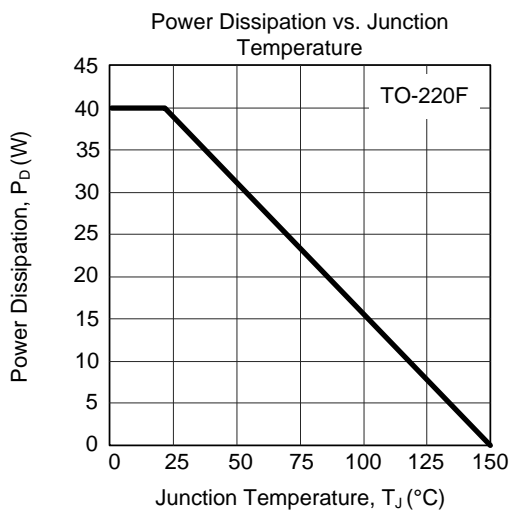
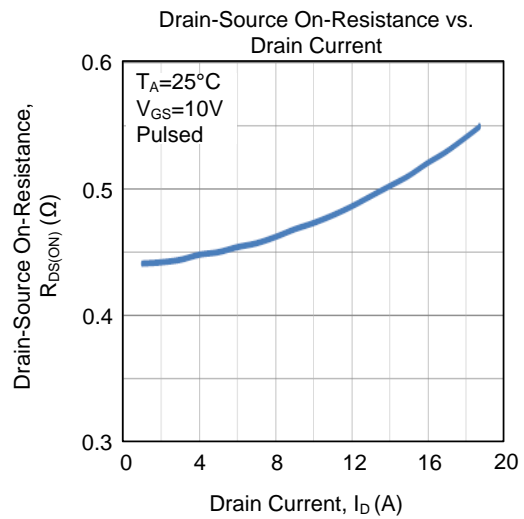
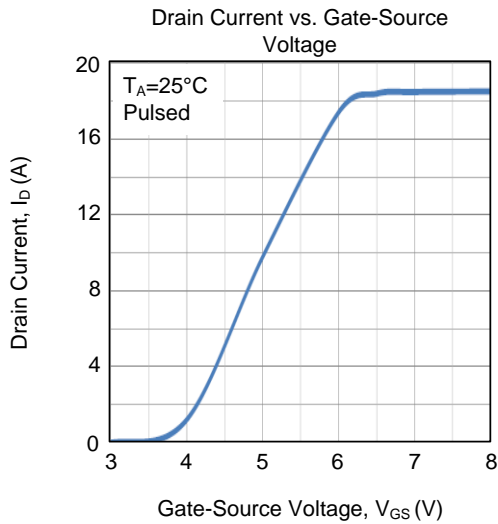
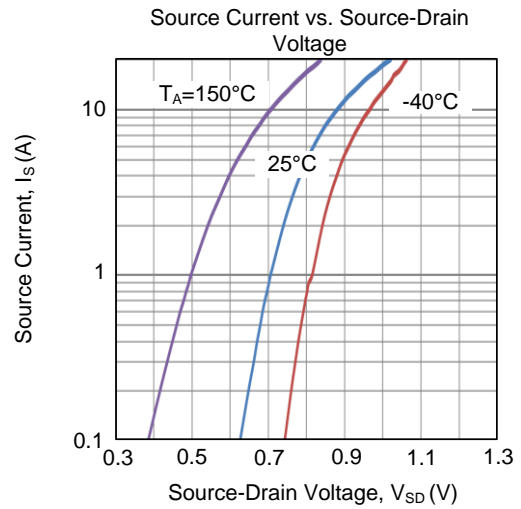
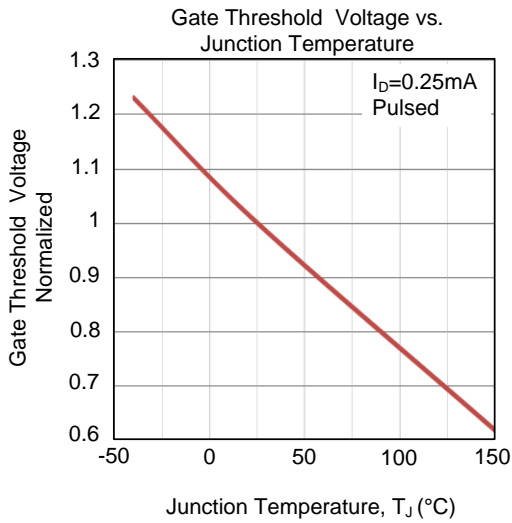

■ TYPICAL CHARACTERISTICS (Cont.)

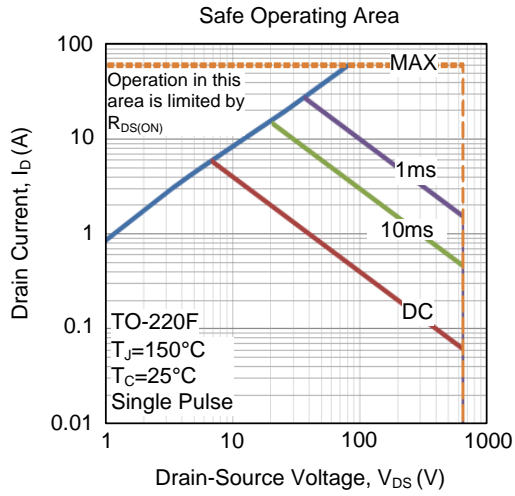

UTC assumes no responsibility for equipment failures that result from using products at values that exceed, even momentarily, rated values (such as maximum ratings, operating condition ranges, or other parameters) listed in products specifications of any and all UTC products described or contained herein. UTC products are not designed for use in life support appliances, devices or systems where malfunction of these products can be reasonably expected to result in personal injury. Reproduction in whole or in part is prohibited without the prior written consent of the copyright owner. UTC reserves the right to make changes to information published in this document, including without limitation specifications and product descriptions, at any time and without notice. This document supersedes and replaces all information supplied prior to the publication hereof.