

Three - Phase Bridge Rectifier

Features

- Easy connections
- Excellent power volume ratio
- Insulated type

Voltage Ratings ($T_J = 25^{\circ}\text{C}$ unless otherwise noted)				
Type number	Voltage code	VRRM, Max. repetitive peak reverse voltage (V)	VRSM, Max. non-repetitive peak reverse voltage (V)	IRRM max @ T_J max (mA)
160MDS	80	800	900	10
	100	1000	1100	
	120	1200	1300	
	140	1400	1500	
	160	1600	1700	



MDS - 160

Thermal and Mechanical Specifications ($T_A = 25^{\circ}\text{C}$ unless otherwise noted)			
Parameters	Symbol	Values	Units
Maximum operating junction temperature range	T_J	- 40 to + 150	$^{\circ}\text{C}$
Maximum storage temperature range	T_{Stg}	- 40 to + 150	$^{\circ}\text{C}$
Maximum thermal resistance, junction to case	$R_{\text{th}(JC)}$	DC operation per module	0.12
		DC operation per junction	0.73
		120 Rect conduction angle per module	0.15
		120 Rect conduction angle per junction	0.88
Maximum thermal resistance, case to heatsink	$R_{\text{th}(CS)}$	0.03	$^{\circ}\text{C}/\text{W}$
Mounting torque $\pm 10\%$	T	to heatsink	4 to 6
		to terminal	3 to 4
Approximate weight		176	g

Electrical Specifications ($T_J = 25^{\circ}\text{C}$ unless otherwise noted)						
Parameters	Conditions		Symbol	Values	Units	
Maximum DC output current	120° Rect conduction angle, $T_C = 85^{\circ}\text{C}$		I_0	160	A	
Maximum peak one-cycle forward, non-repetitive surge current	$t = 10\text{ms}$	No voltage reappplied	$T_J = T_J \text{ max.}$	I_{FSM}	1430	A
	$t = 8.3\text{ms}$				1500	
	$t = 8.3\text{ms}$	100% V_{RRM} reappplied			1200	
	$t = 10\text{ms}$				1260	
Maximum I^2t for fusing	$T = 8.3\text{ms}$	No voltage reappplied	$T_J = T_J \text{ max.}$	I^2t	10200	A^2s
	$T = 10\text{ms}$				9300	
	$T = 8.3\text{ms}$	100% V_{RRM} reappplied			7200	
	$T = 10\text{ms}$				6600	
Maximum J^2vt for fusing	$T = 0.1$ to 10ms , no voltage reappplied		J^2vt	102000	A^2vs	
Low level value of threshold voltage	$[16.7\% * \pi * I_{F(AV)} < I < \pi * I_{F(AV)}]$, @ $T_J \text{ max}$		$V_{F(TO)1}$	0.81	V	
High level value of threshold voltage	$[I > \pi * I_{F(AV)}]$, @ $T_J \text{ max}$		$V_{F(TO)2}$	1.04	V	
Low level value of forward slope resistance	$[16.7\% * \pi * I_{F(AV)} < I < \pi * I_{F(AV)}]$, @ $T_J \text{ max}$		r_1	3.52	$\text{m}\Omega$	
High level value of forward slope resistance	$[I > \pi * I_{F(AV)}]$, @ $T_J \text{ max}$		r_2	3.13	$\text{m}\Omega$	
Maximum forward voltage drop	$I_{pk} = 100\text{A}$, $t_p = 400 \mu\text{s}$ single junction		V_{FM}	1.49	V	
RMS isolation voltage	$f = 50\text{Hz}$, $t = 1\text{ms}$, all terminals shorted		V_{ISO}	4000	V	

Diode Configuration

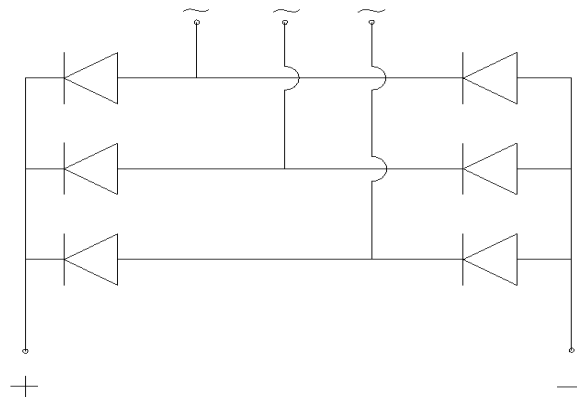

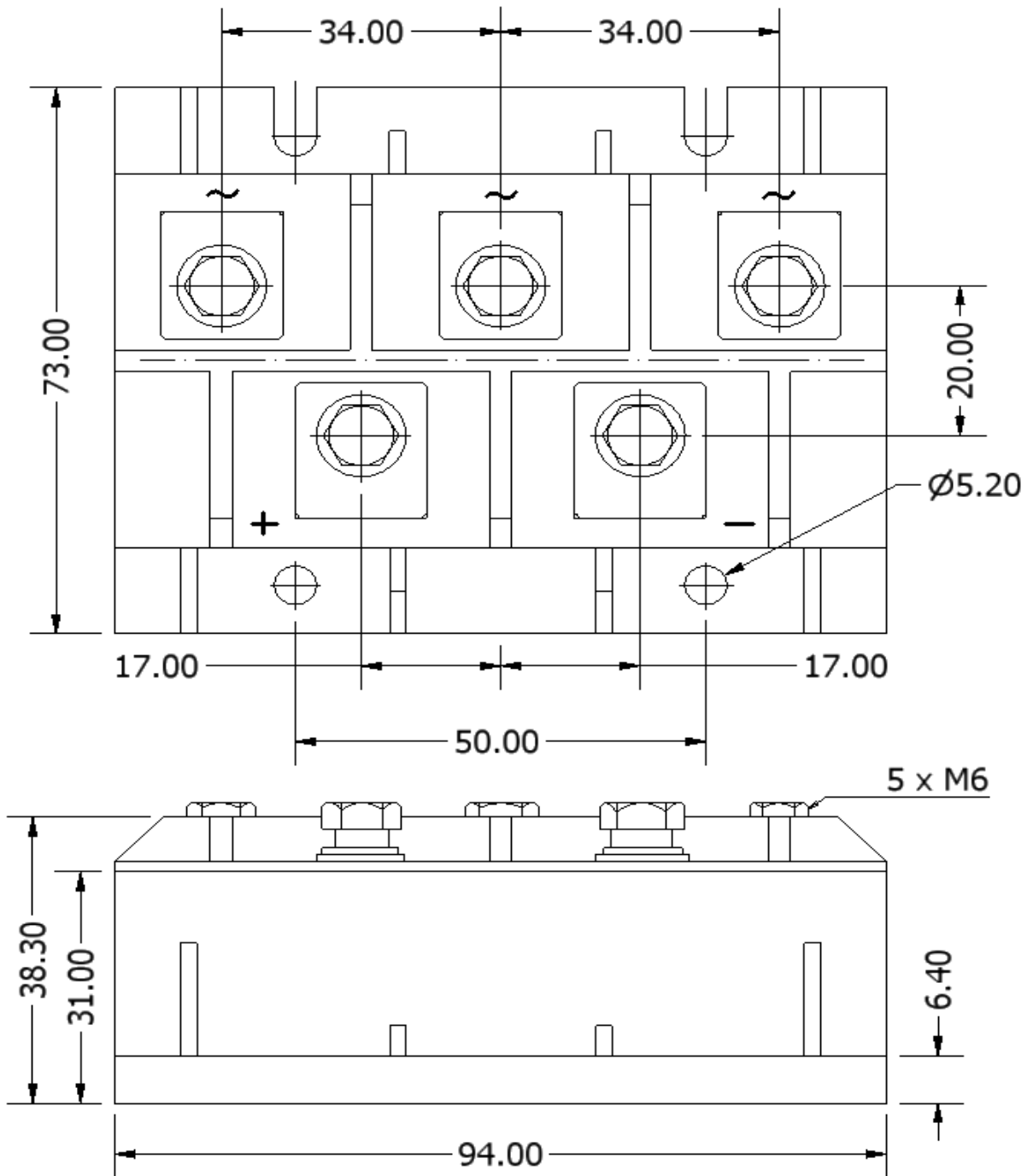

ALL DIMENSIONS IN MM