

# 16HS SERIES 1.8°

## Key Features

- High Torque
- Smooth Movement
- Small Size



## General Specifications

- Bi-polar

Series & Length	Model Number	Holding Torque		Rated Current	Resistance per Phase	Inductance per Phase	Detent Torque		Rotor Inertia	
		mNm	oz-in	A	ohm	mH	mNm	oz-in	g.cm <sup>2</sup>	oz-in <sup>2</sup>
16HS4 36 mm (1.40 in.)	16HS4003-06N	260	36.85	0.40	29	38	15	2.12	30	0.17
	16HS4007-01N	220	31.18	0.65	7	9.6	15	2.12	30	0.17

- Uni-polar

Series & Length	Model Number	Holding Torque		Rated Current	Resistance per Phase	Inductance per Phase	Detent Torque		Rotor Inertia	
		mNm	oz-in	A	ohm	mH	mNm	oz-in	g.cm <sup>2</sup>	oz-in <sup>2</sup>
16HS4 36 mm (1.40 in.)	16HS4005-01N	165	23.38	0.65	7	5.6	15	2.12	30	0.17
	16HS4006-01N	155	21.97	0.30	40	27	15	2.12	30	0.17

- Wiring Connection, Lead Wires, Schematic Diagrams & Stepping Sequence.....Page 62 - 64

## Mechanical Dimension

Series	L	Mass
	mm (in.)	kg (lb.)
16HS4	36 (1.40)	0.21 (0.46)

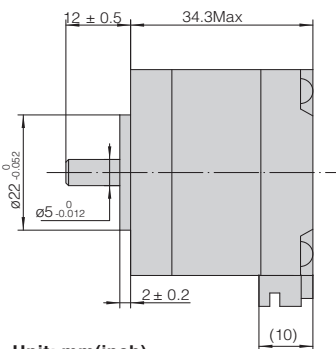

Unit: mm(inch)

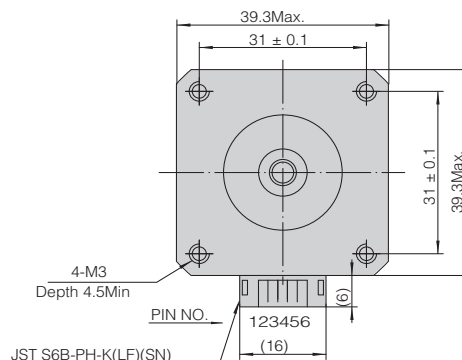

Why Stepping Motor

encapsulated 2 phase NEMA 14

encapsulated 3 phase NEMA 14 NEMA 17

new release 2 phase NEMA 8

new release 2 phase NEMA 14

new release 2 phase NEMA 16

2 phase NEMA 10 25.0 mm (1.00 inch)

2 phase NEMA 11 28.0 mm (1.10 inch)

2 phase NEMA 14 35.0 mm (1.38 inch)

2 phase NEMA 16 39.0 mm (1.53 inch)

2 phase NEMA 17 42.0 mm (1.65 inch)

2 phase NEMA 23 56.0 mm (2.22 inch)

2 phase NEMA 24 60.0 mm (2.36 inch)

2 phase NEMA 34 86.0 mm (3.39 inch)

3 phase NEMA 24 60.0 mm (2.36 inch)

3 phase NEMA 34 86.0 mm (3.39 inch)

how to select

## Dynamic Torque Curves

- Bi-polar

### 16HS4003-06N

Conditions: Bi-polar Constant Current Driver  
 Driver: AMA MS3540M  
 Mode: Full Step

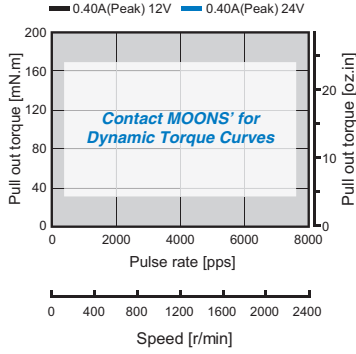

### 16HS4007-01N

Conditions: Bi-polar Constant Current Driver  
 Driver: AMA MS3540M  
 Mode: Full Step

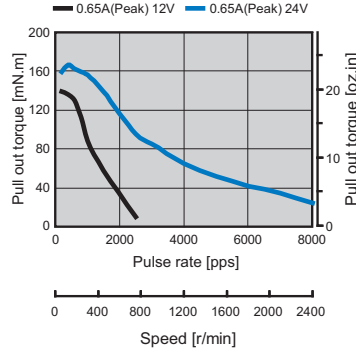

- Uni-polar

### 16HS4005-01N

Conditions: Uni-polar Constant Current Driver  
 Driver: AMA MSU3040M  
 Mode: Full Step

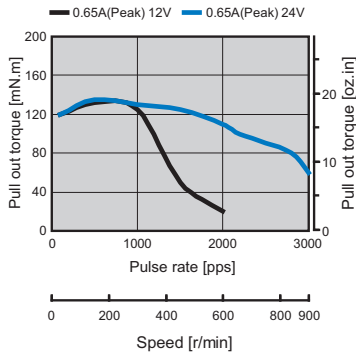

### 16HS4006-01N

Conditions: Uni-polar Constant Current Driver  
 Driver: AMA MSU3040M  
 Mode: Full Step

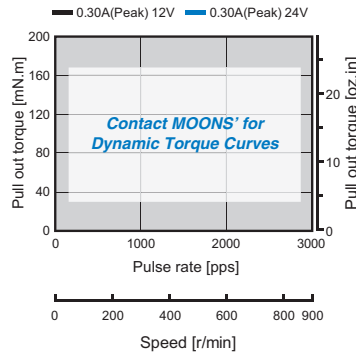

Why Stepping Motor

encapsulated 2 phase NEMA 14

encapsulated 3 phase NEMA 14 NEMA 17

new release 2 phase NEMA 8

new release 2 phase NEMA 14

new release 2 phase NEMA 16

2 phase NEMA 10 25.0 mm (1.00 inch)

2 phase NEMA 11 28.0 mm (1.10 inch)

2 phase NEMA 14 35.0 mm (1.38 inch)

2 phase NEMA 16 39.0 mm (1.53 inch)

2 phase NEMA 17 42.0 mm (1.65 inch)

2 phase NEMA 23 56.0 mm (2.22 inch)

2 phase NEMA 24 60.0 mm (2.36 inch)

2 phase NEMA 34 86.0 mm (3.39 inch)

3 phase NEMA 24 60.0 mm (2.36 inch)

3 phase NEMA 34 86.0 mm (3.39 inch)

how to select