

Nema 17 Stepper Motor

Date:

COMMON RATINGS

Step angle :	1.8°	Dielectric strength :	500VAC
Positional accuracy :	±5%	Insulation resistance :	100Mohm(500VDC)
Number of Phase :	2	Ambient Temperature :	-10°C~50°C
Temperature rise :	80°C MAX	Insulation class :	B
Rotor Inertia :	38gcm ²	Weight :	0.28Kg

SPECIFICATIONS

Holding Torque (2 phases on) Kg.cm	Rated Current/Phase (Amps DC)	Phase Resistance (ohms) ±10%	Voltage Current/Phase (V DC)	Phase Inductance (mH)±20%(1KHz) Typical
2.6	0.4	30	12.0	37

DIMENSIONS unit=mm

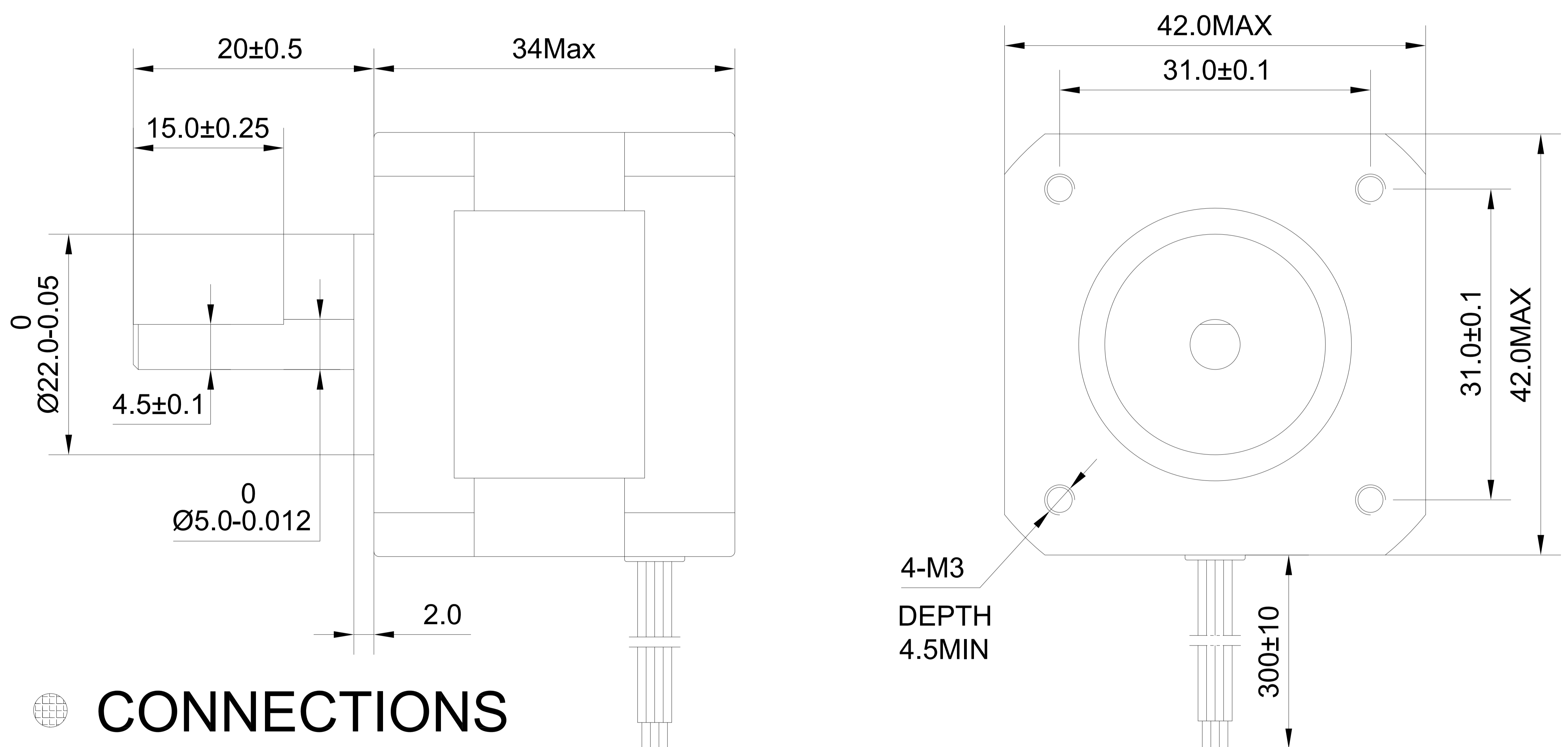

CONNECTIONS

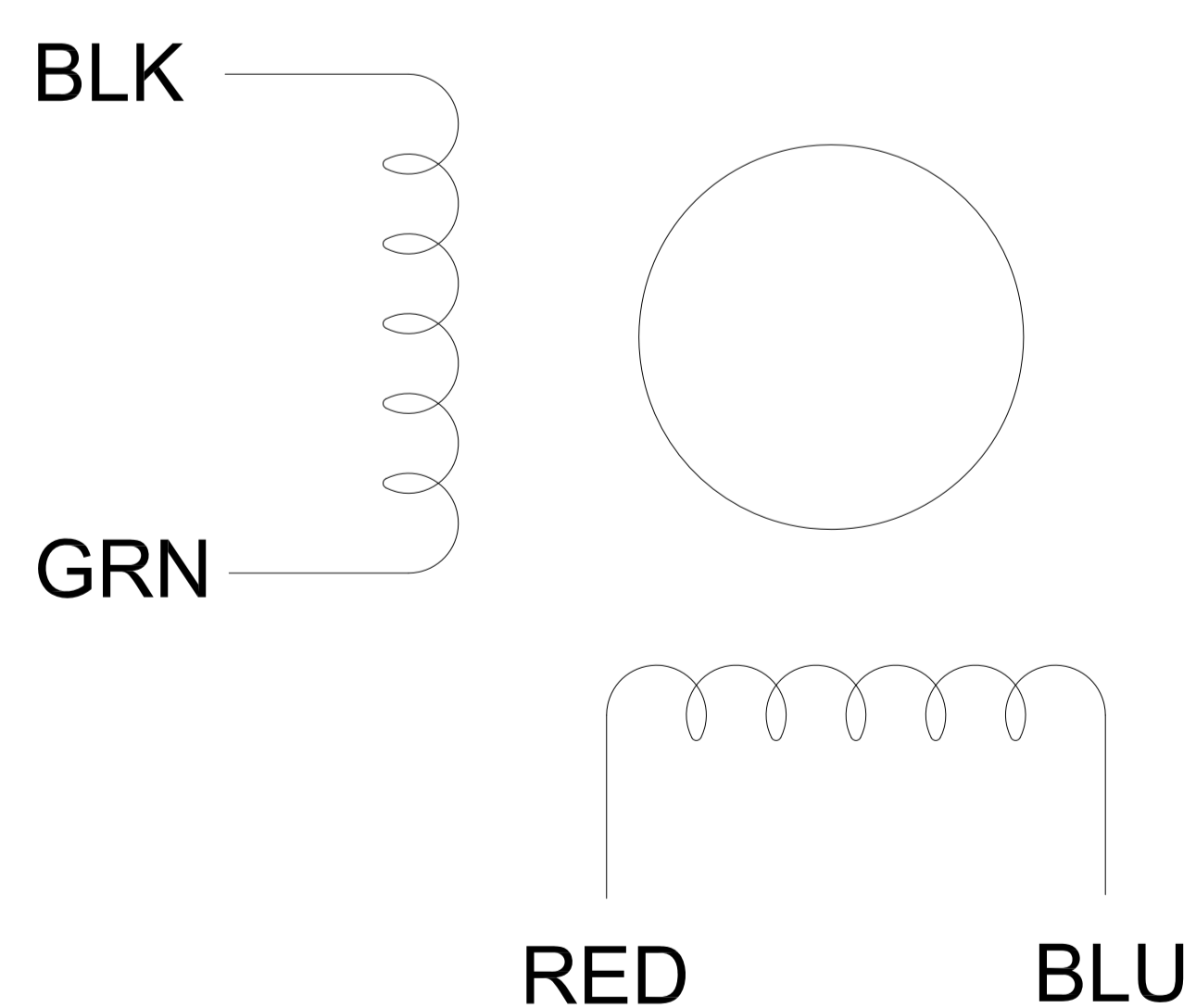

						17HS13-0404S			技术规格书	
标记	处数	分区	更改文件号	签名	日期					
设计			标准化							 www.OMC-StepperOnline.com
审核										
工艺			批准			共 张	第 张			