



Data Specs

17HS4401S 1.7A Torque:43N.cm Stepper Motor

A stepper motor to satisfy all your 3D-Printer, robotics, Linear Motion projects needs! This 4-wire bipolar stepper has 1.8° per step for smooth motion and a nice holding torque. The motor was specified to have a max current of 1.7A/phase so that it could be driven easily with common motor shield for Arduino (or other motor driver) and a wall adapter or lead-acid battery. The motors are supplied with a 50cm long power cable with a 4-pin Harwin female connector already fitted - ready to plug and print!



Brief Data:

- Nema17 Bipolar.
- Number of Phase: 2.
- Step Angle: 1.8°.
- Phase Voltage: 2.6Vdc.
- Phase Current: 1.7A.
- Resistance/Phase: $1.5\Omega \pm 10\%$.
- Inductance: $2.8\text{mH} \pm 20\%$ (1KHz).
- Number of Wire: 4 (100cm Length).
- Holding Torque: 43Ncm.
- Shaft Diameter: $\text{Ø}5\text{mm}$.
- Motor Length: 40mm.
- Rotor Inertia: 54gcm^2 .
- Temperature rise: 80°C Max.
- Insulation Class: B.
- Dielectric Strength: 500VAC/1-minute.
- Mass: 280g.

Mechanical Dimensions:

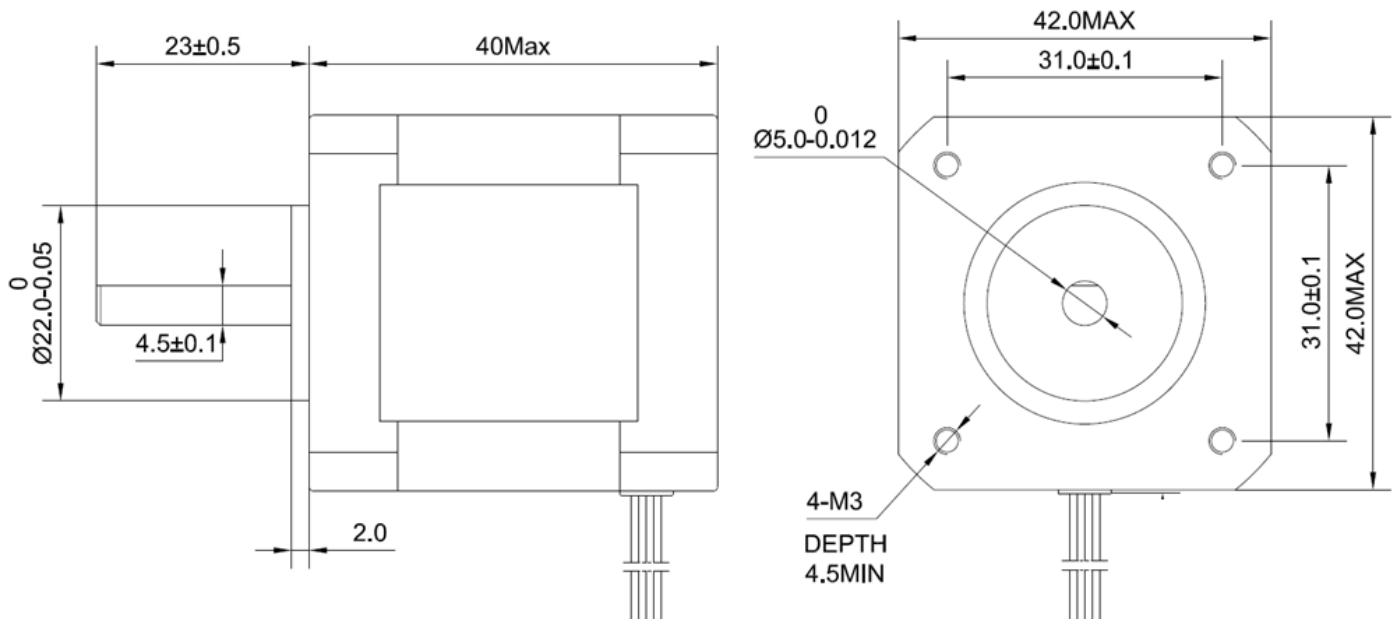

Connection:

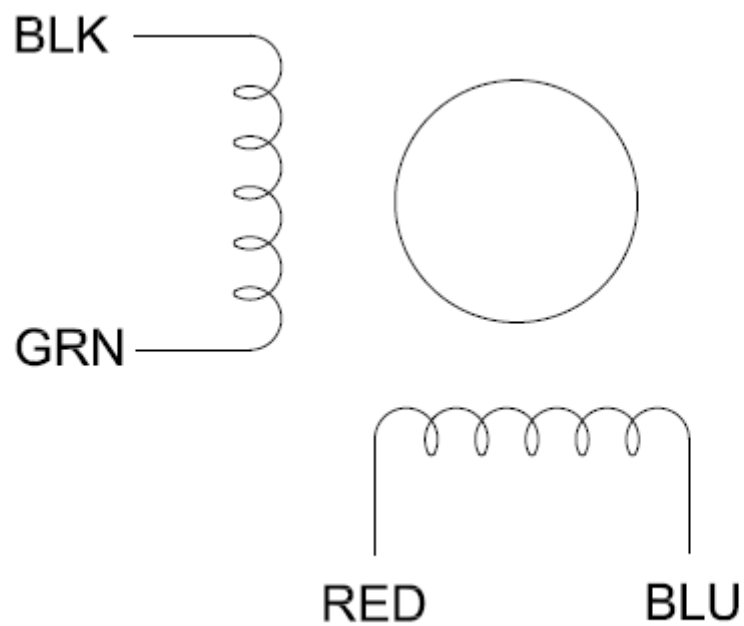

Nema-17 Stepper Motor Body Length Comparison:

