



17N60-ML

Power MOSFET

17A, 600V N-CHANNEL POWER MOSFET

DESCRIPTION

The UTC **17N60-ML** is a high voltage power MOSFET combines advanced planar MOSFET designed to have better characteristics, such as fast switching time, low gate charge, low on-state resistance and high rugged avalanche characteristics. This power MOSFET is usually used in high speed switching applications of switching power supplies and adaptors.

FEATURES

- * $R_{DS(ON)} \leq 0.42 \Omega @ V_{GS}=10V, I_D=8.5A$
- * High Switching Speed

SYMBOL

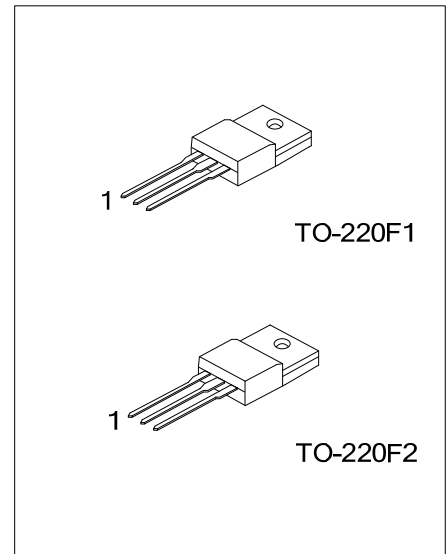
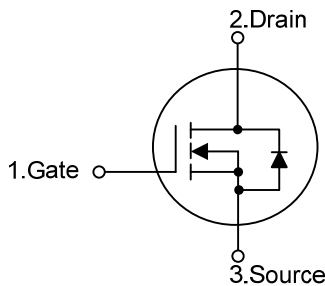

ORDERING INFORMATION

Ordering Number		Package	Pin Assignment			Packing
Lead Free	Halogen Free		1	2	3	
17N60L-TF1-T	17N60G-TF1-T	TO-220F1	G	D	S	Tube
17N60L-TF2-T	17N60G-TF2-T	TO-220F2	G	D	S	Tube

Note: Pin Assignment: G: Gate D: Drain S: Source

<p>17N60G-TF1-T</p> <p>(1)Packing Type</p> <p>(2)Package Type</p> <p>(3)Green Package</p>	<p>(1) T: Tube</p> <p>(2) TF1: TO-220F1, TF2: TO-220F2</p> <p>(3) G: Halogen Free and Lead Free, L: Lead Free</p>
---	---

MARKING

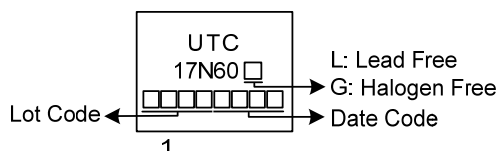

■ ABSOLUTE MAXIMUM RATINGS (unless otherwise specified)

PARAMETER	SYMBOL	RATINGS	UNIT
Drain-Source Voltage	V_{DSS}	600	V
Gate-Source Voltage	V_{GSS}	± 30	V
Continuous Drain Current	Continuous	I_D	17
	Pulsed	I_{DM}	34
Single Pulsed Avalanche Energy	E_{AS}	1058	mJ
Peak Diode Recovery dv/dt (Note 4)	dv/dt	2.1	V/ns
Power Dissipation	P_D	43	W
Junction Temperature	T_J	+150	$^{\circ}C$
Storage Temperature	T_{STG}	-55 ~ +150	$^{\circ}C$

Notes: 1. Absolute maximum ratings are those values beyond which the device could be permanently damaged.

Absolute maximum ratings are stress ratings only and functional device operation is not implied.

2. Repetitive Rating : Pulse width limited by maximum junction temperature.

3. $L=30mH$, $I_{AS}=8.4A$, $V_{DD}=50V$, $R_G=25\Omega$, Starting $T_J = 25^{\circ}C$

4. $I_{SD} \leq 17A$, $di/dt \leq 200A/\mu s$, $V_{DD} \leq BV_{DSS}$, Starting $T_J = 25^{\circ}C$

■ THERMAL DATA

PARAMETER	SYMBOL	RATING	UNIT
Junction to Ambient	θ_{JA}	62.5	$^{\circ}C/W$
Junction to Case	θ_{JC}	2.9	$^{\circ}C/W$

■ ELECTRICAL CHARACTERISTICS

PARAMETER	SYMBOL	TEST CONDITIONS	MIN	TYP	MAX	UNIT
OFF CHARACTERISTICS						
Drain-Source Breakdown Voltage	BV_{DSS}	$I_D=250\mu A$, $V_{GS}=0V$	600			V
Drain-Source Leakage Current	I_{DSS}	$V_{DS}=600V$, $V_{GS}=0V$			10	μA
Gate-Source Leakage Current	Forward	I_{GSS}			+100	nA
	Reverse				-100	nA
ON CHARACTERISTICS						
Gate Threshold Voltage	$V_{GS(TH)}$	$V_{DS}=V_{GS}$, $I_D=250\mu A$	2.0		4.0	V
Static Drain-Source On-State Resistance	$R_{DS(ON)}$	$V_{GS}=10V$, $I_D=8.5A$			0.42	Ω
DYNAMIC PARAMETERS						
Input Capacitance	C_{ISS}	$V_{GS}=0V$, $V_{DS}=25V$, $f=1.0MHz$		2670		pF
Output Capacitance	C_{OSS}			260		pF
Reverse Transfer Capacitance	C_{RSS}			21		pF
SWITCHING PARAMETERS						
Total Gate Charge	Q_G	$V_{DS}=480V$, $V_{GS}=10V$, $I_D=17A$ (Note 1, 2)		78		nC
Gate to Source Charge	Q_{GS}			24		nC
Gate to Drain Charge	Q_{GD}			22		nC
Turn-ON Delay Time	$t_{D(ON)}$	$V_{DD}=100V$, $V_{GS}=10V$, $I_D=17A$, $R_G=25\Omega$ (Note 1, 2)		34		ns
Rise Time	t_R			24		ns
Turn-OFF Delay Time	$t_{D(OFF)}$			204		ns
Fall-Time	t_F			56		ns
SOURCE- DRAIN DIODE RATINGS AND CHARACTERISTICS						
Maximum Body-Diode Continuous Current	I_S				17	A
Maximum Body-Diode Pulsed Current	I_{SM}				34	A
Drain-Source Diode Forward Voltage	V_{SD}	$I_S=17A$, $V_{GS}=0V$			1.4	V
Body Diode Reverse Recovery Time	t_{rr}	$I_S=17A$, $V_{GS}=0V$, $dI_F/dt=100A/\mu s$ (Note 1)		608		ns
Reverse Recovery Charge	Q_{rr}				9.1	μC

Notes: 1. Pulse Test: Pulse width $\leq 600\mu s$, Duty cycle $\leq 2\%$.

2. Essentially independent of operating temperature.

■ TEST CIRCUITS AND WAVEFORMS

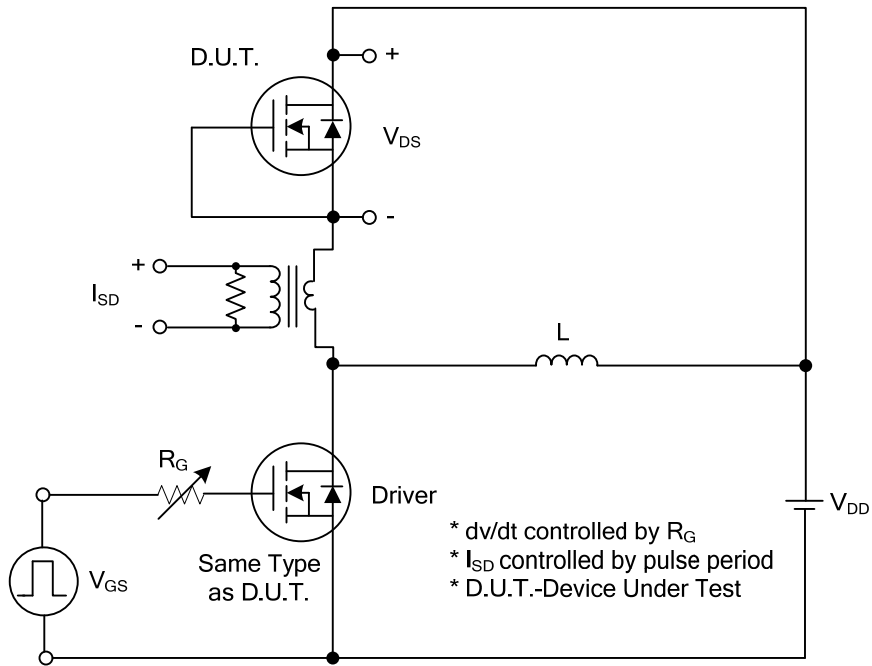

Peak Diode Recovery dv/dt Test Circuit

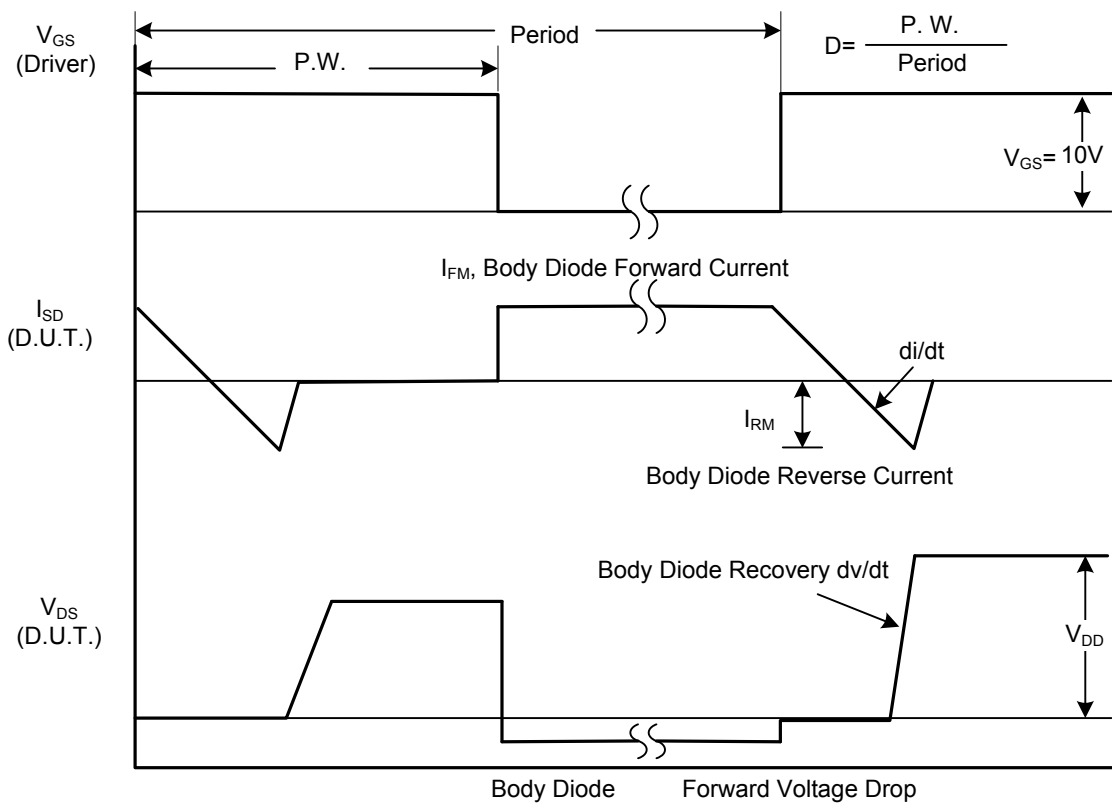

Peak Diode Recovery dv/dt Waveforms

TEST CIRCUITS AND WAVEFORMS

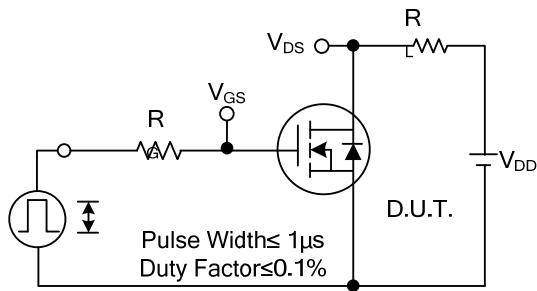

Switching Test Circuit

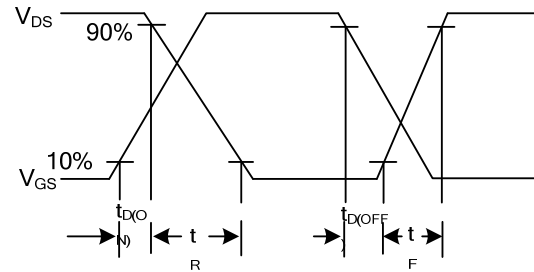

Switching Waveforms

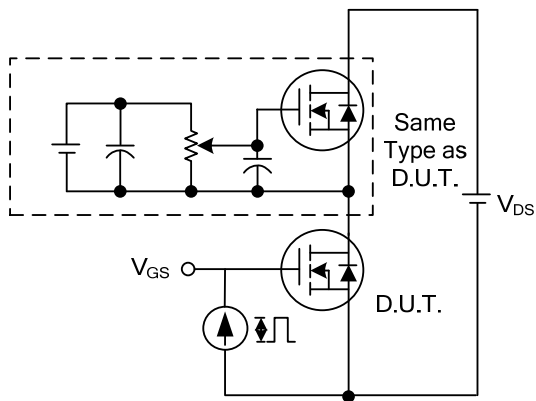

Gate Charge Test Circuit

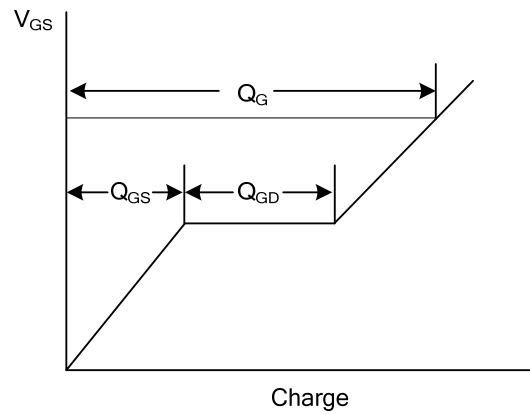

Gate Charge Waveform

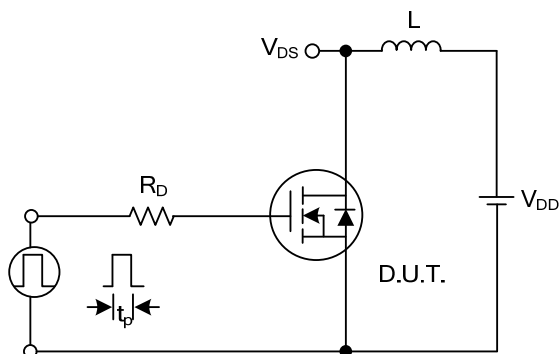

Unclamped Inductive Switching Test Circuit

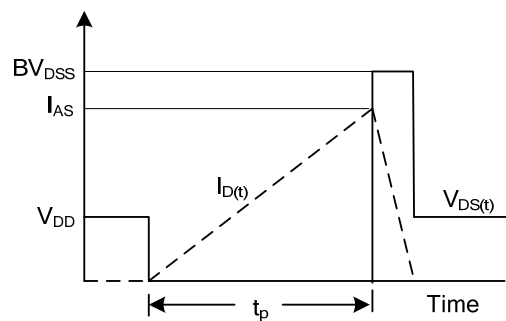

Unclamped Inductive Switching Waveforms

TYPICAL CHARACTERISTICS

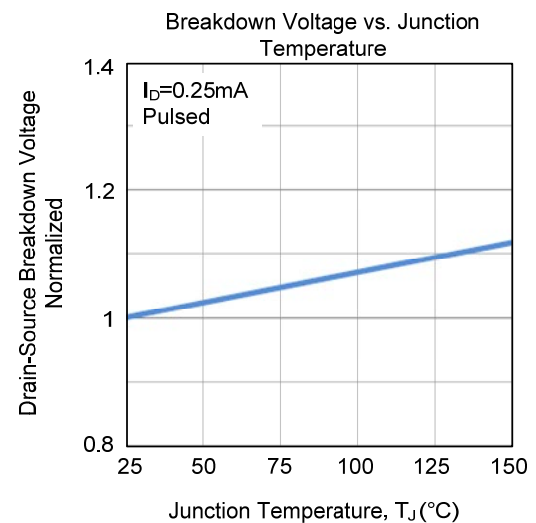
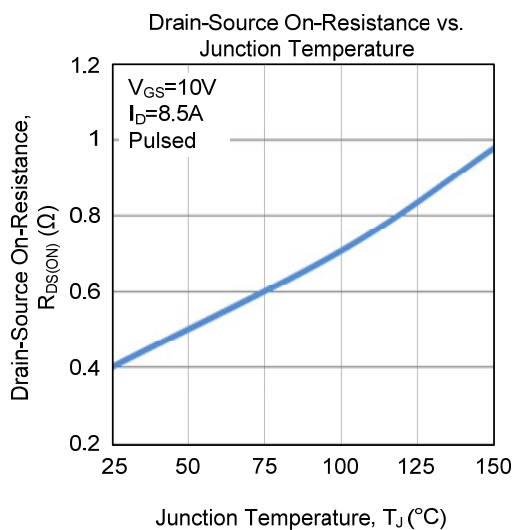
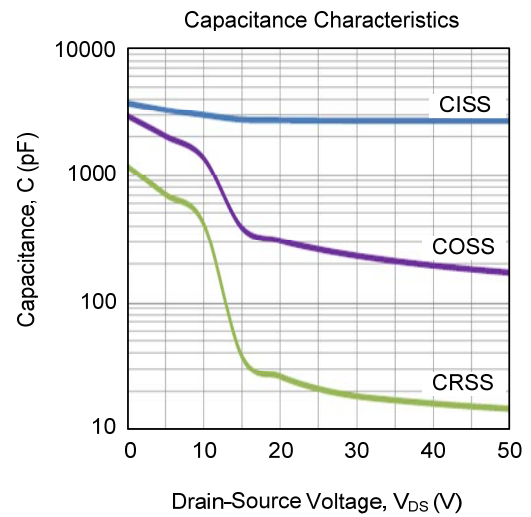
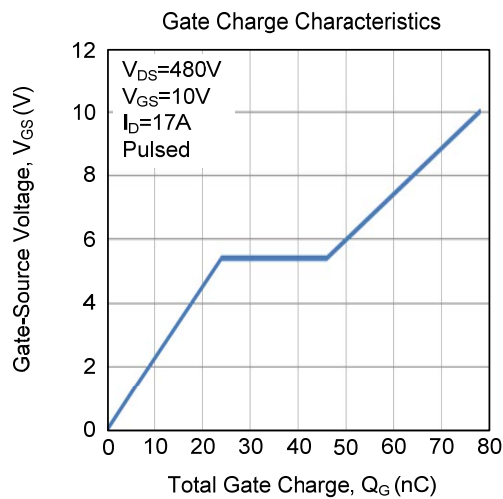
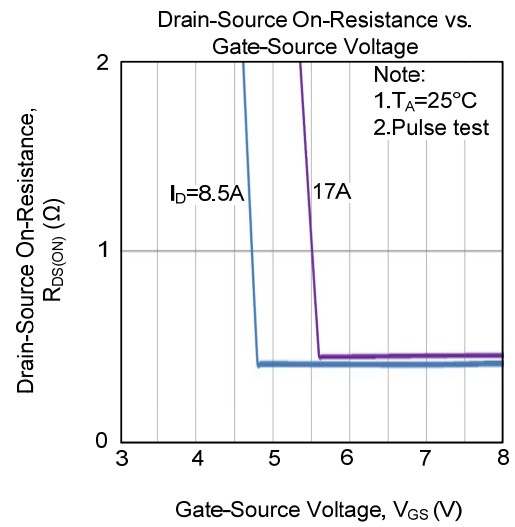
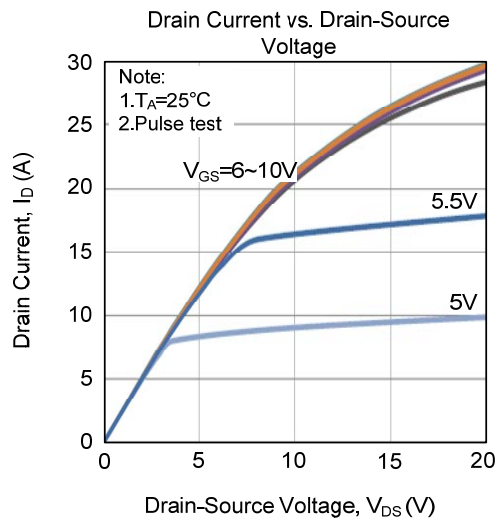

■ TYPICAL CHARACTERISTICS (Cont.)

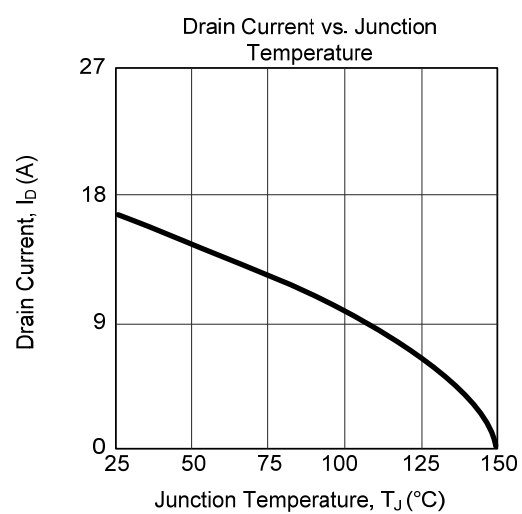
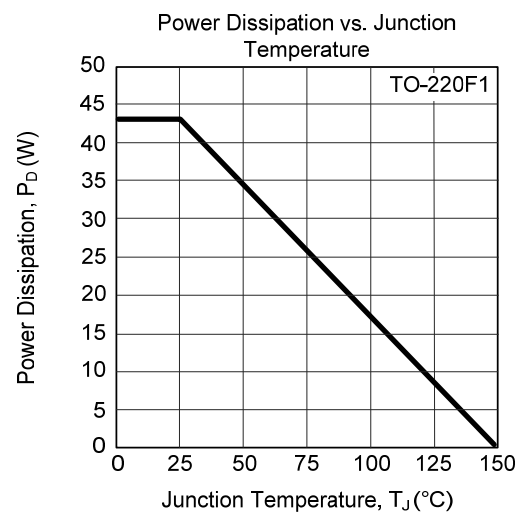
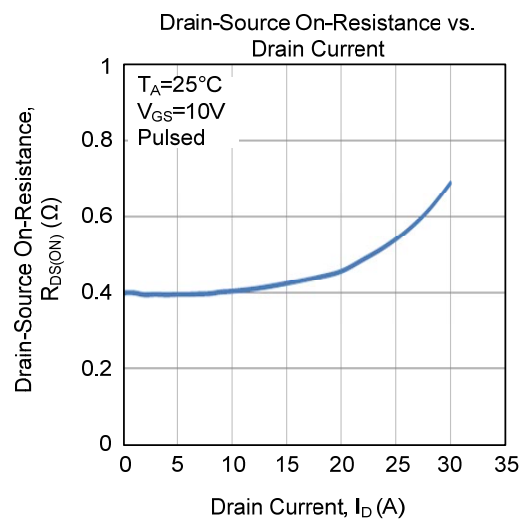
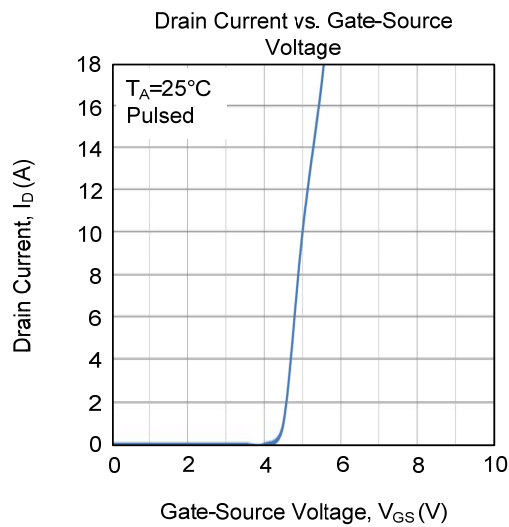
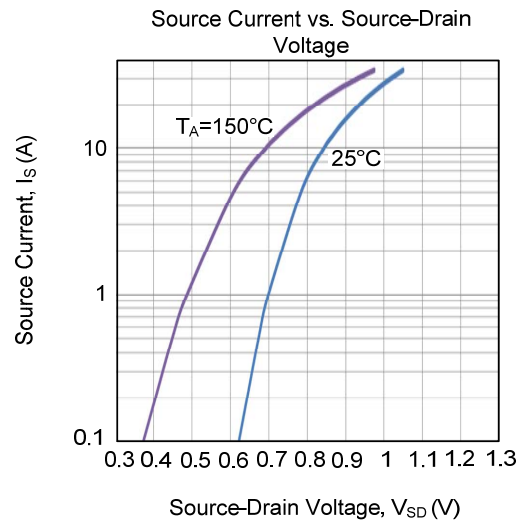
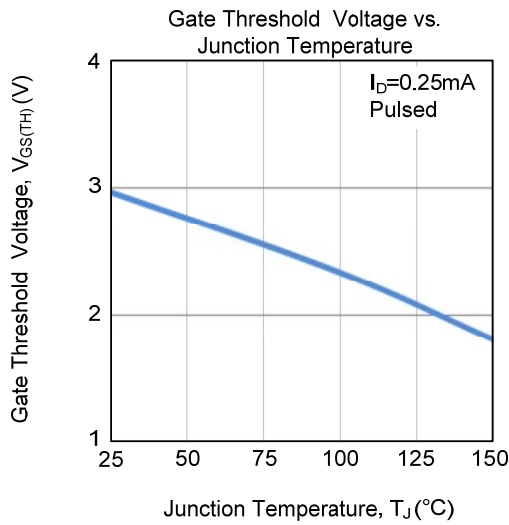

■ TYPICAL CHARACTERISTICS (Cont.)

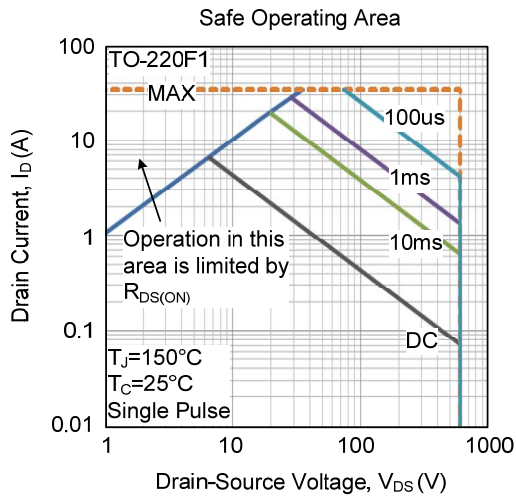

UTC assumes no responsibility for equipment failures that result from using products at values that exceed, even momentarily, rated values (such as maximum ratings, operating condition ranges, or other parameters) listed in products specifications of any and all UTC products described or contained herein. UTC products are not designed for use in life support appliances, devices or systems where malfunction of these products can be reasonably expected to result in personal injury. Reproduction in whole or in part is prohibited without the prior written consent of the copyright owner. UTC reserves the right to make changes to information published in this document, including without limitation specifications and product descriptions, at any time and without notice. This document supersedes and replaces all information supplied prior to the publication hereof.