

Data Sheet

Customer: _____

Product: Multilayer Chip Ceramic Capacitor - C Series _____

Size : 0402/0603/0805/1206/1210/1808/1812/1825/2220/2255 _____

Issued Date: 23-Apr.-2016 _____

Edition: Ver. 4 _____

Record of change

Date	Ver.	Description	Page
30-Oct.-2014	1		
05-Oct.-2015	2	Revised storage condition	21
20-Feb.-2016	3	Revised capacitance range and thickness Delete size 2211	4 ~ 13
23-Apr.-2016	4	Add PCB land pattern recommendation	27

HITANO ENTERPRISE CORP.

7F-7, No. 3, Wu Chuan 1st Road, New Taipei Industrial Park,
New Taipei City, TAIWAN, R.O.C.
Tel: +886 2 2299 1331 (Rep.)
Fax: +886 2 2298 2466, 2298 2969

Prepared by	Checked by	Approved by	Accepted by (customer)
30-Oct.-2014	30-Oct.-2014	30-Oct.-2014	
<i>Andy Hsu</i>	<i>Hwa Wu</i>	<i>Hwa Wu</i>	

Introduction	2
Part Number Code	3
Capacitance Range – NPO	4-7
Capacitance Range – X7R/X5R	8-12
Capacitance Range – Y5V	13
Thickness Code & SPQ	14
Specifications and Test Methods	15-18
Packing	19-22
Soldering & Cleaning	23
Storage and Label	24
PCB Design	25-27

1. Features

Various temperature characteristics cover a wide range in small size.
Mounted either by flow or reflow soldering methods
Excellent dielectric strength due to uniform structure of dielectric layers

2. Applications

MLCC are becoming increasingly important key electronic applications, which are helpful in reducing the size of electronic circuitry. MLCC are used extensively in computers, communicative products, and the detail applications which including the followings:

- Discharge of Stored Energy
- Blockage of Direct Current
- Coupling of Circuit Components
- By-Passing of an AC Signal
- Frequency Discrimination
- Transient Voltage and Arc Suppression
- Surge Protection

3. Construction of MLCC

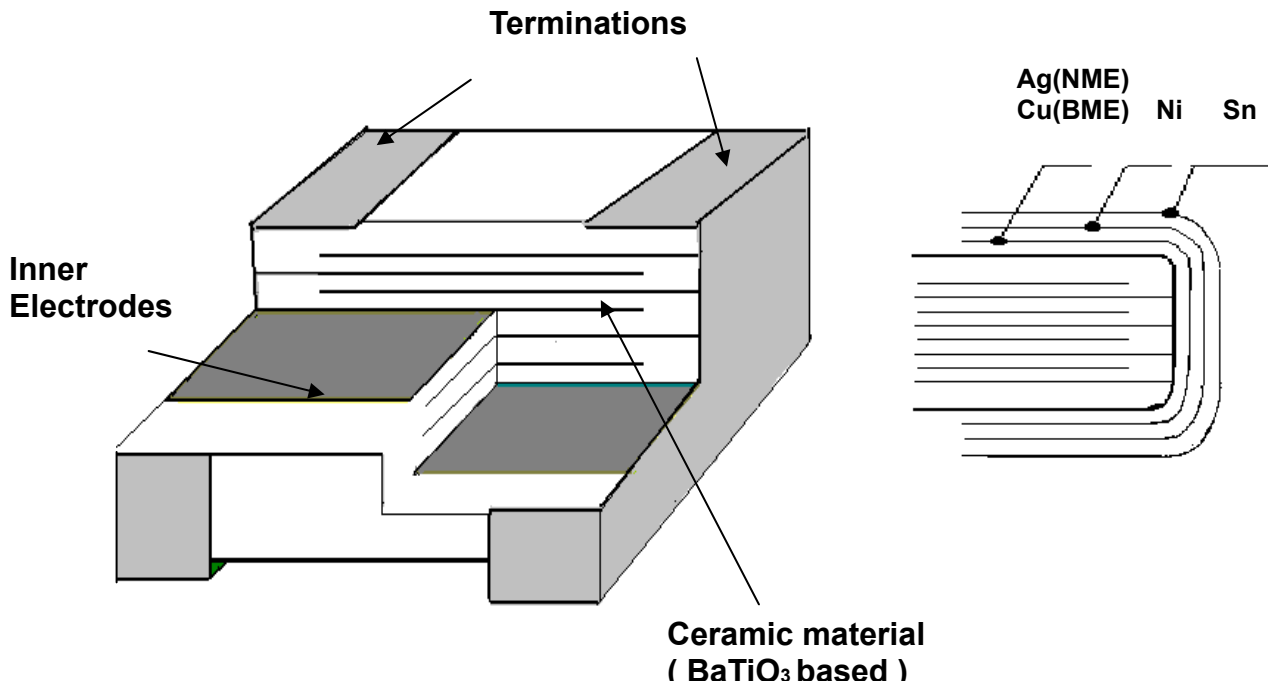

Part Numbering

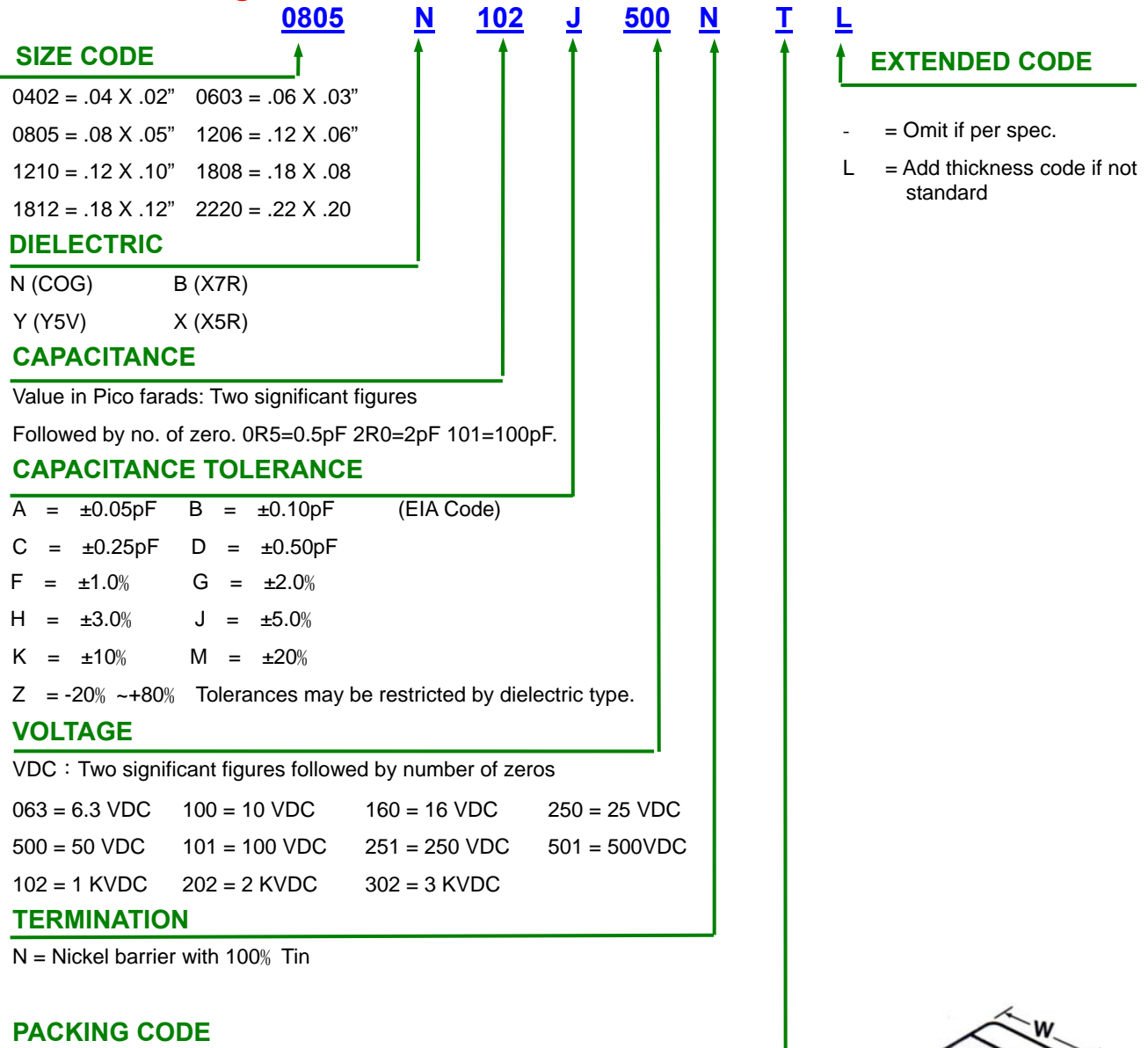

PACKING CODE

B = Bulk in Tray
 05 = 500/Reel 1= 1K/Reel 2= 2K/Reel 3= 3K/Reel (for plastic tape only)
 T= 4K/Reel U= 10K/ Reel V= 15K/ Reel W = 20K/Reel

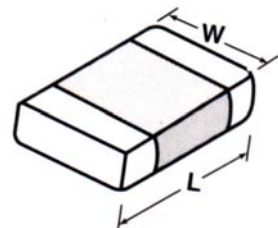

Dimension : (UNIT mm)

	0402	0603	0805	1206	1210	1808	1812	1825	2220	2225
L	1.00±0.05	1.60±0.10	2.00±0.20	3.20±0.20	3.20±0.30	4.50±0.30	4.50±0.30	4.50±0.30	5.70±0.40	5.70±0.40
W	0.50±0.05	0.80±0.10	1.25±0.20	1.60±0.20	2.50±0.20	2.00±0.20	3.20±0.30	6.30±0.40	5.00±0.40	6.30±0.40

Size and capacitance range NPO100V ~ 630V (Medium Voltage)

Size		0402			0603			0805					1206					1210					1812				
(L)	mm	1.00±0.05			1.60±0.10			2.00±0.20					3.20±0.20					3.20±0.30					4.50±0.30				
(W)	mm	0.50±0.05			0.80±0.10			1.25±0.20					1.60±0.20					2.50±0.20					3.20±0.30				
(T)	mm	0.50±0.05			0.80±0.10			1.25±0.10					1.65±0.20					2.50±0.30					3.00±0.30				
(t)	mm	0.15±0.05			0.27~0.60			0.30~0.70					0.30~0.70					0.30~0.70					0.35~1.00				
Cap./ W.V.		100	100	200	250	100	200	250	500	630	100	200	250	500	630	100	200	250	500	630	100	200	250	500	630		
1 - 8.2	pF	S	P	P	P	A	A	A	A	A	H	H	H	H	H												
10-68	pF	S	P	P	P	A	A	A	A	A	H	H	H	H	H	C	C	C	C	C	C	X	X	X	X	X	
82	pF	S	P	P	P	A	A	A	H	H	H	H	H	H	H	C	C	C	C	C	C	X	X	X	X	X	
100	pF	S	P	P	P	A	A	H	H	H	H	H	H	H	H	C	C	C	C	C	C	X	X	X	X	X	
120	pF	S	P	P	P	A	A	H	X	X	H	H	H	H	H	C	C	C	C	C	C	X	X	X	X	X	
150	pF	S	P	P	P	A	H	H	X	X	H	H	H	H	H	C	C	C	C	C	C	X	X	X	X	X	
180	pF	S	P	P	P	A	H	X	X	X	H	H	H	H	H	C	C	C	C	C	C	X	X	X	X	X	
220	pF	S	P	P	P	A	X	X	X	X	H	H	H	H	H	C	C	C	C	C	C	X	X	X	X	X	
270	pF		P	P	P	A	X	X	X	X	H	H	C	C	C	C	C	C	C	C	C	X	X	X	X	X	
330	pF		P	P	P	A	X	X	X	X	H	H	C	C	C	C	C	C	C	C	C	X	X	X	X	X	
390	pF		P	P	P	H	X	X	X	X	H	H	C	C	C	C	C	C	C	C	C	X	X	X	X	X	
470	pF		P	P	P	H	X	X	X	X	H	C	C	C	C	C	C	C	C	C	C	X	X	X	X	X	
560	pF		P	P	P	H	X	X	X	X	H	C	X	X	X	C	C	C	C	C	C	X	X	X	X	X	
680	pF		P	P	P	H	X	X	X	X	H	C	X	X	X	C	C	C	C	C	C	X	X	X	X	X	
820	pF		P	P	P	H	X	X	X	X	H	C	L	L	L	C	C	C	C	C	C	X	X	X	X	X	
1000	pF		P			H	X	X	X	X	H	C	L	L	L	C	X	X	X	X	X	X	X	X	X	X	
1200	pF		P			H	X	X	X	X	H	C	L	L	L	C	X	X	X	X	X	X	X	X	X	X	
1500	pF		P			H	X	X	X	X	H	X	L	L	L	C	X	X	X	X	X	X	X	X	X	X	
1800	pF					H	X	X	X	X	H	X	L	L	L	C	X	X	X	X	X	X	X	X	X	X	
2200	pF					H	X	X	X	X	H	X	L	L	L	C	X	X	X	X	X	X	X	X	X	X	
2700	pF					X					H	X	L	L	L	C	X	X	X	X	X	X	X	X	X	X	
3300	pF					X					H	X	L	L	L	C	X	X	X	X	X	X	X	X	X	X	
3900	pF					X					H	L	L	L	L	C	X	X	X	X	X	X	X	X	X	X	
4700	pF					X					H	L	L	L	L	X	X	X	X	X	X	X	X	X	X	X	
5600	pF					X					H	L	L	L	L	X	X	X	X	X	X	X	X	X	X	X	
6800	pF					X					C	L	L			L	L	L	L	L	L	X	X	X	X	X	
8200	pF										X	L	L			L	L	L	L	L	L	X	X	X	X	X	
10	nF										X					L	Z	Z	Z	Z	Z	X	X	X	X	X	
12	nF										L					L	Z	Z	Z	Z	Z	X	L	L	L	L	
15	nF										L					Z	G	G	G	G	G	X	L	L	L	L	
18	nF										L					G	G	G				L	Z	Z	Z	Z	
22	nF										L					G	G	G				L	Z	Z	Z	Z	
27	nF																					Z	G	G	G	G	
33	nF															G						Z	G	G	G	G	
39	nF																					G	G	G			
47	nF																					G	G	G			
56	nF																					G					
68	nF																					G					

Remark: Customized size and specification is available upon request. Please contact us for further details

Size and capacitance range NPO100V ~ 630V (Medium Voltage)

Size		1825					2220					2225				
(L)	mm	4.50±0.30					5.70±0.40					5.70±0.40				
(W)	mm	6.30±0.40					5.00±0.40					6.30±0.40				
(T)	mm	2.50±0.30					3.00±0.20					3.00±0.20				
(t)	mm	0.35~1.00					0.35~1.00					0.35~1.00				
Cap. \\ W.V		100	200	250	500	630	100	200	250	500	630	100	200	250	500	630
10	pF	L	L	L	L	L	L	L	L	L	L	L	L	L	L	L
12	pF	L	L	L	L	L	L	L	L	L	L	L	L	L	L	L
15	pF	L	L	L	L	L	L	L	L	L	L	L	L	L	L	L
18	pF	L	L	L	L	L	L	L	L	L	L	L	L	L	L	L
22	pF	L	L	L	L	L	L	L	L	L	L	L	L	L	L	L
27	pF	L	L	L	L	L	L	L	L	L	L	L	L	L	L	L
33	pF	L	L	L	L	L	L	L	L	L	L	L	L	L	L	L
39	pF	L	L	L	L	L	L	L	L	L	L	L	L	L	L	L
47	pF	L	L	L	L	L	L	L	L	L	L	L	L	L	L	L
56	pF	L	L	L	L	L	L	L	L	L	L	L	L	L	L	L
68	pF	L	L	L	L	L	L	L	L	L	L	L	L	L	L	L
82	pF	L	L	L	L	L	L	L	L	L	L	L	L	L	L	L
100	pF	L	L	L	L	L	L	L	L	L	L	L	L	L	L	L
120	pF	L	L	L	L	L	L	L	L	L	L	L	L	L	L	L
150	pF	L	L	L	L	L	L	L	L	L	L	L	L	L	L	L
180	pF	L	L	L	L	L	L	L	L	L	L	L	L	L	L	L
220	pF	L	L	L	L	L	L	L	L	L	L	L	L	L	L	L
270	pF	L	L	L	L	L	L	L	L	L	L	L	L	L	L	L
330	pF	L	L	L	L	L	L	L	L	L	L	L	L	L	L	L
390	pF	L	L	L	L	L	L	L	L	L	L	L	L	L	L	L
470	pF	L	L	L	L	L	L	L	L	L	L	L	L	L	L	L
560	pF	L	L	L	L	L	L	L	L	L	L	L	L	L	L	L
680	pF	L	L	L	L	L	L	L	L	L	L	L	L	L	L	L
820	pF	L	L	L	L	L	L	L	L	L	L	L	L	L	L	L
1000	pF	L	L	L	L	L	L	L	L	L	L	L	L	L	L	L
1200	pF	L	L	L	L	L	L	L	L	L	L	L	L	L	L	L
1500	pF	L	L	L	L	L	L	L	L	L	L	L	L	L	L	L
1800	pF	L	L	L	L	L	L	L	L	L	L	L	L	L	L	L
2200	pF	L	L	L	L	L	L	L	L	L	L	L	L	L	L	L
2700	pF	L	L	L	L	L	L	L	L	L	L	L	L	L	L	L
3300	pF	L	L	L	L	L	L	L	L	L	L	L	L	L	L	L
3900	pF	L	L	L	L	L	L	L	L	L	L	L	L	L	L	L
4700	pF	L	L	L	L	L	L	L	L	L	L	L	L	L	L	L
5600	pF	L	L	L	L	L	L	L	L	L	L	L	L	L	L	L
6800	pF	L	L	L	L	L	L	L	L	L	L	L	L	L	L	L
10000	pF	L	L	L	L	L	L	L	L	L	L	L	L	L	L	L
12000	pF	L	L	L	L	L	L	L	L	L	L	L	L	L	L	L
15000	pF	L	L	L	L	L	L	L	L	L	L	L	L	L	L	L
18000	pF	L	L	L	L	L	L	L	L	L	L	L	L	L	L	L
22000	pF	L	L	L	L	L	L	L	L	L	L	L	L	L	L	L
27000	pF	L	L	L	Z	Z	L	L	L	Z	Z	L	L	L	L	L
33000	pF	L	L	L	Z	Z	L	Z	Z	Z	Z	L	L	L	L	L
39000	pF	L	Z	Z	G	G	L	Z	Z	G	G	L	Z	Z	Z	Z
47000	pF	L	Z	Z	G	G	L	G	G	G	G	L	Z	Z	Z	Z
56000	pF	Z	G	G	G	G	Z	G	G	G	G	L	G	G	G	G
68000	pF	Z	G	G	G	G	Z	G	G			Z	G	G	G	G
82000	pF	G	G	G			G	G	G			Z	G	G	G	G
100000	pF	G					G					G	G	G		

Size and capacitance range NPO1000V ~ 4000V (High Voltage)

Size		0805	1206			1210			1808				1812				1825				2220				2225			
(L)	mm	2.00±0.20	3.20±0.20			3.20±0.30			4.50±0.30				4.50±0.30				4.50±0.30				5.70±0.40				5.70±0.40			
(W)	mm	1.25±0.20	1.60±0.20			2.50±0.20			2.00±0.20				3.20±0.30				6.30±0.40				5.00±0.40				6.30±0.40			
(T)	mm	1.25±0.10	1.65±0.20			2.50±0.30			2.00±0.20				3.00±0.30				2.50±0.30				3.00±0.20				3.00±0.20			
(t)	mm	0.30~0.70	0.30~0.70			0.30~0.70			0.35~1.00				0.35~1.00				0.35~1.00				0.35~1.00				0.35~1.00			
Cap./ W.V.		1K	1K	2K	3K	1K	2K	3K	1K	2K	3K	4K	1K	2K	3K	4K	1K	2K	3K	4K	1K	2K	3K	4K	1K	2K	3K	4K
1.5	pF	X	H	H																								
1.8	pF	X	X	H																								
2.2~8.2	pF	X	X	H					X	X	X	X																
10	pF	X	H	H	L	C	C	L	X	X	X	X	X	X	X	Z	Z	Z	Z	Z	Z	Z	Z	Z	Z	Z	Z	Z
12	pF	X	H	H	L	C	C	L	X	X	X	X	X	X	X	Z	Z	Z	Z	Z	Z	Z	Z	Z	Z	Z	Z	Z
15	pF	X	H	H	L	C	C	L	X	X	X	X	X	X	X	Z	Z	Z	Z	Z	Z	Z	Z	Z	Z	Z	Z	Z
18	pF	X	H	H	L	C	C	L	X	X	X	X	X	X	X	Z	Z	Z	Z	Z	Z	Z	Z	Z	Z	Z	Z	Z
22	pF	X	H	H	L	C	C	L	X	X	X	L	X	X	X	X	Z	Z	Z	Z	Z	Z	Z	Z	Z	Z	Z	Z
27	pF	X	H	H	L	C	C	L	X	X	X	L	X	X	X	X	Z	Z	Z	Z	Z	Z	Z	Z	Z	Z	Z	Z
33	pF	X	H	C	L	C	C	L	X	X	X	Z	X	X	X	X	Z	Z	Z	Z	Z	Z	Z	Z	Z	Z	Z	Z
39	pF	X	H	C	L	C	C	L	X	X	X	Z	X	X	X	X	Z	Z	Z	Z	Z	Z	Z	Z	Z	Z	Z	Z
47	pF	X	C	C	L	C	C	L	X	X	X		X	X	X	L	Z	Z	Z	Z	Z	Z	Z	Z	Z	Z	Z	Z
56	pF	X	C	X	L	C	X	L	X	X	X		X	X	X	L	Z	Z	Z	Z	Z	Z	Z	Z	Z	Z	Z	Z
68	pF	X	C	X	L	C	X	L	X	X	X		X	X	X	Z	Z	Z	Z	Z	Z	Z	Z	Z	Z	Z	Z	Z
82	pF	X	X	X	L	C	X	L	X	X	X		X	X	X	Z	Z	Z	Z	Z	Z	Z	Z	Z	Z	Z	Z	Z
100	pF	X	X	X		X	X	L	X	X	Z		X	X	X		Z	Z	Z	Z	Z	Z	Z	Z	Z	Z	Z	Z
120	pF	X	X	L		X	X	L	X	X	Z		X	X	X		Z	Z	Z	Z	Z	Z	Z	Z	Z	Z	Z	Z
150	pF	X	X	L		X	L	L	X	Z	Z		X	X	X		Z	Z	Z	Z	Z	Z	Z	Z	Z	Z	Z	Z
180	pF	X	L	L		X	L	L	X	Z	Z		X	X	Z		Z	Z	Z	Z	Z	Z	Z	Z	Z	Z	Z	Z
220	pF	X	L	L		L	L	L	X	Z	Z		X	X	Z		Z	Z	Z		Z	Z	Z	Z	Z	Z	Z	Z
270	pF	X	L	L		L	L		Z	Z	Z		X	Z	Z		Z	Z	Z		Z	Z	Z	G	Z	Z	Z	Z
330	pF	X	L	L		L	L		Z	Z	Z		X	Z	Z		Z	Z	Z		Z	Z	G	G	Z	Z	Z	G
390	pF	X	L	L		L	L		Z	Z	Z		X	Z	Z		Z	Z	Z		Z	Z	G		Z	Z	Z	
470	pF		L	L		L	L		Z	Z	Z		Z	Z	Z		Z	Z	Z		Z	Z	G		Z	Z	Z	
560	pF		L			L	L		Z	Z	Z		Z	Z	Z		Z	Z	Z		Z	Z	G		Z	Z	Z	
680	pF		L			L	L		Z	Z			Z	Z	Z		Z	Z	G		Z	Z	G		Z	Z	Z	
820	pF		L			L	L		Z	Z			Z	Z	G		Z	Z	G		Z	Z	G		Z	G	G	
1000	pF		L			L	Z		Z	Z			Z	Z	G		Z	Z	G		Z	Z	G		Z	G	G	
1200	pF		L			L	Z		Z	Z			Z	Z			Z	Z	G		G	G	G		Z	G	G	
1500	pF					Z	G		Z	Z			Z	Z			Z	G	G		G	G	G		Z	G	G	
1800	pF					G	G		Z	Z			Z	Z			Z	G	G		G	G	G		Z	G	G	
2200	pF					G			Z				Z	Z			Z	G	G		G	G	G		Z	G	G	
2700	pF					G			Z				Z	G			Z	G	G		G	G	G		Z	G	G	
3300	pF					G			Z				Z	G			Z	G			G	G			Z	G	G	
3900	pF					G			Z				G				G	G			G	G			Z	G		
4700	pF												G				G	G			G	G			Z	G		
5600	pF												G				G	G			G	G			G	G		
6800	pF																G	G			G	G			G	G		
8200	pF																G	G			G	G			G	G		
10000	pF																G				G				G	G		
12000	pF																G				G				G			

Remark: Customized size and specification is available upon request. Please contact us for further details

5. Size and capacitance range X7R10V ~ 50V (Low Voltage)

Size		0402				0603				0805				1206				1210			1812		2220		
(L)	mm	1.00±0.05				1.60±0.10				2.00±0.20				3.20±0.20				3.20±0.30			4.50±0.30		5.70±0.40		
(W)	mm	0.50±0.05				0.80±0.10				1.25±0.20				1.60±0.20				2.50±0.20			3.20±0.20		5.00±0.40		
(T)	mm	0.50±0.05				0.80±0.12				1.25±0.20				1.65±0.20				2.50±0.20			3.00±0.20		3.00±0.20		
(t)	mm	0.15~0.35				0.27~0.60				0.30~0.70				0.30~0.70				0.30~0.70			0.35~1.00		0.35~1.00		
Cap. \\ W.V.		10	16	25	50	10	16	25	50	10	16	25	50	10	16	25	50	16	25	50	25	50	25	50	
100	pF				S				P				H												
120	pF				S				P				H												
150	pF				S				P				H												
180	pF				S				P				H												
220	pF				S				P				H					H							
270	pF				S				P				H					H							
330	pF				S				P				H					H							
390	pF				S				P				H					H							
470	pF				S				P				H					H							
560	pF				S				P				H					H							
680	pF				S				P				H					H							
820	pF				S				P				H					H							
1000	pF				S				P				H					H							
1200	pF				S				P				H					H							
1500	pF				S				P				H					H							
1800	pF				S				P				H					H							
2200	pF				S				P				H					H							
2700	pF				S				P				H					H							
3300	pF				S				P				H					H							
3900	pF				S				P				H					H							
4700	pF				S				P				H					H							
5600	pF				S				P				H					H							
6800	pF				S				P				H					H							
8200	pF				S				P				H					H							
10	nF			S	S				P				H					H							
12	nF			S					P				H					H							
15	nF			S					P				H					H							
18	nF			S					P				H					H							
22	nF			S	S				P				H					H							
27	nF			S					P				H					H							
33	nF			S					P				H					H							
39	nF			S					P				H					H							
47	nF		S	S	S				P	P			H					H							
56	nF		S						P	P			H					H							
68	nF		S						P	P			H					H							
82	nF		S						P	P			H					H							
100	nF	S	S	S	S			P	P	P			H					H					X		
150	nF					P	P	P			X	X	X					X					X		
220	nF	S	S			P	P	P	P		X	X	X					X					X		
330	nF					P	P	P	P		X	X	X			X	X						X		
470	nF					P	P	P	P		X	X	X			X	L						X		
680	nF					P	P				X	X	X		X	X	L						L/Z		
1.0	uF					P	P	P	P	X	X	X	X		X	X	L			L			L/Z	Z	
2.2	uF					P				X	X	X	X		L	L	L			Z			Z	Z	
3.3	uF																			G			G	Z	
4.7	uF									X	X	X			L	L	L		Z	G	Z	G		Z	
10	uF									X	*X				L	L	L		Z	Z/G	G	Z	Z/G	Z	G
22	uF														I				G	G		Z/G		G	

Remark: Customized size and specification is available upon request. Please contact us for further details

Size and capacitance range X7R100V ~ 630V (Medium Voltage)

Size		0603			0805				1206					1210					1812				
(L)	mm	1.60±0.10			2.00±0.20				3.20±0.20					3.20±0.30					4.50±0.30				
(W)	mm	0.80±0.10			1.25±0.20				1.60±0.20					2.50±0.20					3.20±0.20				
(T)	mm	0.80±0.12			1.25±0.20				1.65±0.25					2.50±0.20					2.50±0.20				
(t)	mm	0.27~0.60			0.30~0.70				0.30~0.70					0.30~0.70					0.35~1.00				
Cap. \\ W.V.		100	200	250	100	200	250	500 630	100	200	250	500	630	100	200	250	500	630	100	200	250	500	630
100	pF	P	P	P	H	H	H	H	H	H	H												
150	pF	P	P	P	H	H	H	H	H	H	H												
220	pF	P	P	P	H	H	H	H	H	H	X	X	C	C	C	X	X						
330	pF	P	P	P	H	H	H	H	H	H	X	X	C	C	C	X	X	X	X	X	X	X	
470	pF	P	P	P	H	H	H	H	H	H	X	X	C	C	C	X	X	X	X	X	X	X	
560	pF	P	P	P	H	H	H	H	H	H	X	X	C	C	C	X	X	X	X	X	X	X	
680	pF	P	P	P	H	H	H	H	H	H	X	X	C	C	C	X	X	X	X	X	X	X	
1000	pF	P	P	P	H	H	H	H	H	H	X	X	C	C	C	X	X	X	X	X	X	X	
1500	pF	P	P	P	H	H	H	H	H	H	X	X	C	C	C	X	X	X	X	X	X	X	
2200	pF	P	P	P	H	H	H	H	H	H	X	X	C	C	C	X	X	X	X	X	X	X	
3300	pF	P	P	P	H	H	H	H	H	H	X	X	C	C	C	X	X	X	X	X	X	X	
4700	pF	P	P	P	H	H	H	X	H	H	H	X	X	C	C	C	X	X	X	X	X	X	
5600	pF	P	P	P	H	H	H	X	H	H	H	X	X	C	C	C	X	X	X	X	X	X	
6800	pF	P	P	P	H	H	H	X	H	H	H	X	X	C	C	C	X	X	X	X	X	X	
10	nF	P	P	P	H	H	H	X	H	H	H	X	X	C	C	C	X	X	X	X	X	X	
15	nF	P	P	P	H	H	H	X	H	X	X	X	X	C	C	C	X	X	X	X	X	X	
22	nF	P			H	H	H	X	H	X	X	L	L	C	C	C	X	X	X	X	X	X	
33	nF	P			X	X	X		X	L	L	L	L	C	C	C	L	L	X	X	X	X	
47	nF	P			X	X	X		X	L	L	L	L	C	X	X	L	L	X	X	X	X	
56	nF	P			X	X	X		X	L	L	L	L	C	X	X	L	L	X	X	X	L	
68	nF	P			X	X	X		X	L	L			C	L	L	L/Z	L/Z	X	X	X	L	
100	nF	P			X	X			X	L	L			C	L	L	G	G	L	X	X	L	
150	nF				X				L					X	G	G	G	G	L	L	L	G	
220	nF				X				L					X	G	G			L	L	L	G	
330	nF								L					L	G	G			L	L	Z	G	
470	nF								L					L	G	G			L	L	Z	G	
680	nF								L					Z	G	G			Z	G	G		
1.0	uF								L					Z					Z	G	G		
1.5	uF								L					G					Z				
2.2	uF								L					G					G				
3.3	uF																		G				

Remark: Customized size and specification is available upon request. Please contact us for further details

Size and capacitance range X7R100V ~ 630V (Medium Voltage)

Size		1825					2220					2225				
(L)	mm	4.50±0.30					5.70±0.40					5.70±0.40				
(W)	mm	6.30±0.40					5.00±0.40					6.30±0.40				
(T)	mm	2.50±0.30					3.00±0.20					3.00±0.20				
(t)	mm	0.35~1.00					0.35~1.00					0.35~1.00				
Cap. \\ W.V		100	200	250	500	630	100	200	250	500	630	100	200	250	500	630
470	pF															
680	pF															
1000	pF	Z	Z	Z	Z	Z	Z	Z	Z	Z	Z	Z	Z	Z	Z	Z
1500	pF	Z	Z	Z	Z	Z	Z	Z	Z	Z	Z	Z	Z	Z	Z	Z
2200	pF	Z	Z	Z	Z	Z	Z	Z	Z	Z	Z	Z	Z	Z	Z	Z
3300	pF	Z	Z	Z	Z	Z	Z	Z	Z	Z	Z	Z	Z	Z	Z	Z
4700	pF	Z	Z	Z	Z	Z	Z	Z	Z	Z	Z	Z	Z	Z	Z	Z
6800	nF	Z	Z	Z	Z	Z	Z	Z	Z	Z	Z	Z	Z	Z	Z	Z
10	nF	Z	Z	Z	Z	Z	Z	Z	Z	Z	Z	Z	Z	Z	Z	Z
15	nF	Z	Z	Z	Z	Z	Z	Z	Z	Z	Z	Z	Z	Z	Z	Z
22	nF	Z	Z	Z	Z	Z	Z	Z	Z	Z	Z	Z	Z	Z	Z	Z
33	nF	Z	Z	Z	Z	Z	Z	Z	Z	Z	Z	Z	Z	Z	Z	Z
47	nF	Z	Z	Z	Z	Z	Z	Z	Z	Z	Z	Z	Z	Z	Z	Z
68	nF	Z	Z	Z	Z	Z	Z	Z	Z	Z	Z	Z	Z	Z	Z	Z
100	nF	Z	Z	Z	Z	Z	Z	Z	Z	Z	Z	Z	Z	Z	Z	Z
150	nF	Z	Z	Z	Z	Z	Z	Z	Z	Z	Z	Z	Z	Z	Z	Z
220	nF	Z	Z	Z	Z	Z	Z	Z	Z	Z	Z	Z	Z	Z	Z	Z
330	nF	Z	Z	Z	Z	Z	Z	Z	Z	Z	Z	Z	Z	Z	Z	Z
470	nF	Z	Z	Z	Z	Z	Z	Z	Z	Z	Z	Z	Z	Z	G	G
680	nF	Z	Z	Z	Z	Z	Z	Z	Z	Z	Z	Z	Z	Z	G	G
1.0	uF	Z	Z	Z			Z	Z	Z			Z	Z	Z	G	G
2.2	uF	Z	G	G			Z	G	G			Z	G	G		
3.3	uF	Z					Z					Z				
4.7	uF	G					G					G				
6.8	uF						U					G				
10	uF						U					G				

Remark: Customized size and specification is available upon request. Please contact us for further details

Size and capacitance range X7R1000V ~ 4000V (High Voltage)

Size	0805	1206	1210	1808	1812	1825	2220	2225																
(L) mm	2.00±0.20	3.20±0.20	3.20±0.30	4.50±0.30	4.50±0.30	4.50±0.30	5.70±0.40	5.70±0.40																
(W) mm	1.25±0.20	1.60±0.20	2.50±0.20	2.00±0.20	3.20±0.20	6.30±0.40	5.00±0.40	6.30±0.40																
(T) mm	1.25±0.20	1.65±0.20	2.50±0.20	2.00±0.20	3.00±0.20	2.50±0.30	3.00±0.20	3.00±0.20																
(t) mm	0.30~0.70	0.30~0.70	0.30~0.70	0.35~1.00	0.35~1.00	0.35~1.00	0.35~1.00	0.35~1.00																
Cap.\\W.V.	1K	1K	2K	1K	2K	1K	2K	3K	1K	2K	3K	4K	1K	2K	3K	4K	1K	2K	3K	4K	1K	2K	3K	4K
100 pF	H	X	X																					
120 pF	H	X	X																					
150 pF	H	X	X			X	X	X																
180 pF	H	X	X			X	X	X																
220 pF	H	X	X			X	X	X																
270 pF	H	X	X	X	L	X	X	X	X	X	L	Z				Z					Z			Z
330 pF	H	X	X	X	L	X	X	Z	X	X	L	Z				Z					Z			Z
390 pF	H	X	X	X	L	X	X	Z	X	X	L	Z				Z					Z			Z
470 pF	H	X	X	X	L	X	X	Z	X	X	L	Z				Z					Z			Z
560 pF	H	X	X	X	L	X	X	Z	X	X	L	Z				Z					Z			Z
680 pF	H	X	X	X	L	X	X	Z	X	X	Z	Z				Z					Z			Z
820 pF	H	X	X	X	L	X	X	Z	X	X	Z	Z				Z					Z			Z
1000 pF	H	X	X/L	X	L	X	X	Z	X	X	Z	Z	Z	Z	Z	Z	Z	Z	Z	Z	Z	Z	Z	Z
1200 pF	H	X	L	X	Z	X	Z	Z	X	X	Z	G	Z	Z	Z	G	Z	Z	Z	G	Z	Z	Z	G
1500 pF	X	X	L	X	Z	X	Z	Z	X	X	Z	G	Z	Z	Z	G	Z	Z	Z	G	Z	Z	Z	G
1800 pF	X	X	L	X	Z	X	Z	Z	X	L	G	G	Z	Z	Z	G	Z	Z	Z	G	Z	Z	Z	G
2200 pF	X	X	L	X	Z	X	Z	Z	X	L	G		Z	Z	Z		Z	Z	Z		Z	Z	Z	
2700 pF	X	X	L	X	G	X	Z		X	L	G		Z	Z	Z		Z	Z	Z		Z	Z	Z	
3300 pF	X	X	L	X	G	X	Z		X	Z	G		Z	Z	Z		Z	Z	Z		Z	Z	Z	
3900 pF	X	X		L	G	X	Z		X	Z	G		Z	Z	Z		Z	Z	Z		Z	Z	Z	
4700 pF	X	X		L	G	X	Z		X	Z	G		Z	Z	Z		Z	Z	Z		Z	Z	Z	
5600 pF	X	X		L	G	Z	Z		X	G			Z	Z	G		Z	Z	Z		Z	Z	G	
6800 pF	X	X		L	G	Z	Z		X	G			Z	Z	G		Z	Z	G		Z	Z	G	
8200 pF	X	X		L	G	Z			X	G			Z	Z	G		Z	G	G		Z	Z	G	
10 nF		X		L		Z			X/L	G			Z	Z	G		Z	G	G		Z	Z	G	
12 nF		L		L		Z			Z				Z	G	U		Z	G	U		Z	G	G	
15 nF		L		L		Z			Z				Z	G	U		Z	G	U		Z	G	G	
18 nF		L		L		Z			G				Z	G	U		Z	U	U		Z	G	U	
22 nF		L		L		Z			G				Z	G			Z	U			Z	G		
27 nF				L		Z			G				Z	U			Z	U			Z	G		
33 nF				L		Z			G				Z	U			Z	U			Z	G		
39 nF				Z		Z			G				Z	U			Z	U			Z	U		
47 nF				G		Z			G				Z	U			Z	U			Z	U		
56 nF				G		Z			G				Z	U			Z	U			Z	U		
68 nF				G		Z			G				Z				G				Z			
82 nF									G				G				G				Z			
100 nF									G				G				G				G			
120 nF													U				G				U			
150 nF													U				U				U			
180 nF													U				U				U			
220 nF													U				U				U			
330 nF													U				U				U			
390 nF													U				U				U			

6. Capacitance range Y5V 6.3V ~ 50V

Size		0402			0603					0805					1206					1210					1812				
(L)	mm	1.00±0.05			1.600±0.10					2.00±0.20					3.20±0.20					3.20±0.30					4.50±0.30				
(W)	mm	0.50±0.05			0.80±0.10					1.25±0.20					1.60±0.20					2.50±0.20					3.20±0.30				
(T)	mm	0.50±0.05			0.80±0.12					1.25±0.20					1.65±0.20					2.00±0.20					2.50±0.20				
(t)	mm	0.15~0.35			0.27~0.60					0.30~0.70					0.30~0.70					0.30~0.70					0.35~1.00				
Cap.// W.V.		6.3	10	16	6.3	10	16	25	50	6.3	10	16	25	50	6.3	10	16	25	50	6.3	10	16	25	10	16	25	50		
10	nF			S					P					A					H										
15	nF			S					P					A					H										
22	nF			S					P					A					H										
33	nF			S					P					A					H										
47	nF			S					P					A					H										
68	nF			S					P					A					H										
100	nF			S					P				A	A					H										
150	nF							P	P				A	A					H										
220	nF		S				P	P	P				A	A					H										
330	nF		S				P	P					H	H					H										
470	nF	S	S			P	P	P				H	H	H					H										
680	nF	S				P	P					X	X	X				H	X										
1.0	uF	S				P	P					X	X	X				X	X										
2.2	uF				P	P					X	X	X				X	X	X										
3.3	uF				P						X	X					X	X											
4.7	uF				P						X	X					X	X											
10	uF									X	X					X	X			Z	X	L				G			
22	uF									X					L	L				Z	Z					G			
47	uF														L					Z	Z			G					
100	uF																			G				G					

Thickness Code & Standard Packing Q'ty per reel

Thickness Code	Chip Size	Chip Thickness	Max Tape Thickness	Q'ty of carboard tape in		Q'ty of Embosses tape in	
				7" reel	13" reel	7" reel	13" reel
S	0402	0.50±0.05 mm	0.60 mm	10,000	50,000	--	--
P	0603	0.80±0.10 mm	0.95 mm	4,000	15,000	--	--
A	0805	0.60±0.10 mm	0.75 mm	4,000	15,000	--	--
H		0.85±0.10 mm	0.95 mm	4,000	15,000	--	--
X		1.25±0.10 mm	1.80 mm	--	--	3,000	10,000
H	1206	0.85±0.10 mm	0.90 mm	4,000	15,000	--	--
C		0.95±0.10 mm	1.80 mm			3,000	10,000
X		1.25±0.10 mm	1.80 mm	--	--	3,000	10,000
L		1.65±0.20 mm	1.80 mm	--	--	2,000	--
C	1210	0.95±0.10 mm	1.80 mm			3,000	10,000
X		1.25±0.10 mm	1.80 mm	--	--	2,000	--
L		1.65±0.20 mm	1.80 mm	--	--	2,000	--
Z		2.00±0.20 mm	2.20 mm	--	--	2,000	--
G		2.50±0.20 mm	2.75 mm	--	--	1,000	--
X	1808	1.25±0.10 mm	1.80 mm	--	--	2,000	--
F		1.40±0.20 mm	1.80 mm	--	--	2,000	--
L		1.65±0.20 mm	1.80 mm	--	--	2,000	--
Z		2.00±0.20 mm	2.20 mm	--	--	1,000	--
X	1812	1.25±0.20 mm	1.80 mm	--	--	1,000	--
L		1.65±0.20 mm	1.80 mm			1,000	
Z		2.00±0.20 mm	2.20 mm	--	--	1,000	--
G		2.50±0.20 mm	2.75 mm	--	--	500	--
U		2.80±0.30 mm	3.00 mm	--	--	500	--
Z	1825	2.00±0.20 mm	2.20 mm	--	--	1,000	--
G		2.50±0.20 mm	2.75 mm	--	--	500	--
U		2.80±0.30 mm	3.00 mm	--	--	500	
Z	2220	2.00±0.20 mm	2.20 mm	--	--	500	--
G		2.50±0.20 mm	2.75 mm	--	--	500	--
U		2.80±0.30 mm	3.00 mm	--	--	500	--
Z	2225	2.00±0.20 mm	2.20 mm	--	--	1,000	--
G		2.50±0.20 mm	2.75 mm	--	--	500	--

7. SPECIFICATIONS AND TEST METHODS

No	Item	Test Method	Specification																																						
1	Capacitance	<p>The capacitance shall be measured at 25°C at the frequency and voltage shown below:</p> <table border="1" style="width: 100%; border-collapse: collapse;"> <tr> <td style="width: 15%;">Type</td> <td style="width: 25%;">NPO ($\leq 1\text{nF}$)</td> <td style="width: 25%;">NPO$>1\text{nF}$, Y5V, X7R/X5R</td> <td style="width: 35%;">C $\geq 10\mu\text{F}$</td> </tr> <tr> <td>Item</td> <td></td> <td></td> <td></td> </tr> <tr> <td>Freq.</td> <td>1\pm0.1Mhz</td> <td>1\pm0.1KHz</td> <td>120H</td> </tr> <tr> <td>Voltage</td> <td>1\pm0.2Vrms</td> <td>1\pm0.2Vrms</td> <td>0.5\pm0.2 Vrms</td> </tr> </table>	Type	NPO ($\leq 1\text{nF}$)	NPO $>1\text{nF}$, Y5V, X7R/X5R	C $\geq 10\mu\text{F}$	Item				Freq.	1 \pm 0.1Mhz	1 \pm 0.1KHz	120H	Voltage	1 \pm 0.2Vrms	1 \pm 0.2Vrms	0.5 \pm 0.2 Vrms	<p>Within the specified tolerance</p> <p style="color: red;">Remark: For ClassII(X7R/X5R,Y5V), Before initial test, please perform De-aging process as below: Heat up to 150°C for 1Hr and then set form 48\pm4 Hrs at room temp.</p>																						
Type	NPO ($\leq 1\text{nF}$)	NPO $>1\text{nF}$, Y5V, X7R/X5R	C $\geq 10\mu\text{F}$																																						
Item																																									
Freq.	1 \pm 0.1Mhz	1 \pm 0.1KHz	120H																																						
Voltage	1 \pm 0.2Vrms	1 \pm 0.2Vrms	0.5 \pm 0.2 Vrms																																						
2	Q value / Dissipation Factor	<p>D.F. shall be measured at 25°C at the frequency and voltage shown a o. 1</p> <p style="text-align: center;">EXCEPTION OF D.F.</p> <p>X7R/X5R</p> <table border="1" style="width: 100%; border-collapse: collapse;"> <thead> <tr> <th>r</th> <th>D.F</th> <th>Exc ption of D.F.</th> </tr> </thead> <tbody> <tr> <td>\geq 50V</td> <td>$\leq 3.5\%$</td> <td>0603$\geq 47\text{nF}$, 0805$\geq 0.18\mu\text{F}$, 1206$\geq 0.47\mu\text{F}$, 1210$\geq 1.0\mu\text{F}$</td> </tr> <tr> <td rowspan="3">25V</td> <td>$\leq 5\%$</td> <td>0805$\geq 1.0\mu\text{F}$, 1210$\geq 10\mu\text{F}$</td> </tr> <tr> <td>$\leq 7\%$</td> <td>0603$\geq 0.33\mu\text{F}$, 1206$\geq 4.7\mu\text{F}$</td> </tr> <tr> <td>$\leq 10\%$</td> <td>0603$\geq 0.47\mu\text{F}$,0805$\geq 2.2\mu\text{F}$ 1206$\geq 6.8\mu\text{F}$,0402$\geq 0.1\mu\text{F}$</td> </tr> <tr> <td rowspan="2">16V</td> <td>$\leq 5\%$</td> <td>0402$\geq 33\text{nF}$, 0603$\geq 0.15\mu\text{F}$ 0805$\geq 0.68\mu\text{F}$, 1206$\geq 2.2\mu\text{F}$, 1210$\geq 4.7\mu\text{F}$,</td> </tr> <tr> <td>$\leq 10\%$</td> <td>0603$\geq 0.68\mu\text{F}$, 0805$\geq 2.2\mu\text{F}$, 1206$\geq 4.7\mu\text{F}$, 1210$\geq 22\mu\text{F}$,</td> </tr> <tr> <td>10V</td> <td>$\leq 10\%$</td> <td>0402&0603$\geq 0.33\mu\text{F}$,0805$\geq 2.2\mu\text{F}$, 1206$\geq 2.2\mu\text{F}$, 1210$\geq 22\mu\text{F}$</td> </tr> </tbody> </table> <p>Y5V</p> <table border="1" style="width: 100%; border-collapse: collapse;"> <thead> <tr> <th>Vr</th> <th>D.F</th> <th>Exception o .F.</th> </tr> </thead> <tbody> <tr> <td>$\geq 50\text{V}$</td> <td>$\leq 7\%$</td> <td>0603$\geq 0.1\mu\text{F}$, 0805$\geq 0.47\mu\text{F}$, 1206$\geq 4.7\mu\text{F}$</td> </tr> <tr> <td rowspan="2">25V</td> <td>$\leq 9\%$</td> <td>0402$\geq 47\text{nF}$, 0805$\geq 0.47\mu\text{F}$</td> </tr> <tr> <td>$\leq 12.5\%$</td> <td>121 /10μF</td> </tr> <tr> <td>16V</td> <td>$\leq 9\%$</td> <td>0402$\geq 0.068\mu\text{F}$, 0603$\geq 0.68\mu\text{F}$</td> </tr> <tr> <td>16V ($\geq 1\mu\text{F}$)</td> <td>$\leq 12.5\%$</td> <td>0603$\geq 2.2\mu\text{F}$,0805$\geq 3.3\mu\text{F}$, 1206$\geq 10\mu\text{F}$,1210$\geq 22\mu\text{F}$, 1812$\geq 47\mu\text{F}$,</td> </tr> </tbody> </table>	r	D.F	Exc ption of D.F.	\geq 50V	$\leq 3.5\%$	0603 $\geq 47\text{nF}$, 0805 $\geq 0.18\mu\text{F}$, 1206 $\geq 0.47\mu\text{F}$, 1210 $\geq 1.0\mu\text{F}$	25V	$\leq 5\%$	0805 $\geq 1.0\mu\text{F}$, 1210 $\geq 10\mu\text{F}$	$\leq 7\%$	0603 $\geq 0.33\mu\text{F}$, 1206 $\geq 4.7\mu\text{F}$	$\leq 10\%$	0603 $\geq 0.47\mu\text{F}$,0805 $\geq 2.2\mu\text{F}$ 1206 $\geq 6.8\mu\text{F}$,0402 $\geq 0.1\mu\text{F}$	16V	$\leq 5\%$	0402 $\geq 33\text{nF}$, 0603 $\geq 0.15\mu\text{F}$ 0805 $\geq 0.68\mu\text{F}$, 1206 $\geq 2.2\mu\text{F}$, 1210 $\geq 4.7\mu\text{F}$,	$\leq 10\%$	0603 $\geq 0.68\mu\text{F}$, 0805 $\geq 2.2\mu\text{F}$, 1206 $\geq 4.7\mu\text{F}$, 1210 $\geq 22\mu\text{F}$,	10V	$\leq 10\%$	0402&0603 $\geq 0.33\mu\text{F}$,0805 $\geq 2.2\mu\text{F}$, 1206 $\geq 2.2\mu\text{F}$, 1210 $\geq 22\mu\text{F}$	Vr	D.F	Exception o .F.	$\geq 50\text{V}$	$\leq 7\%$	0603 $\geq 0.1\mu\text{F}$, 0805 $\geq 0.47\mu\text{F}$, 1206 $\geq 4.7\mu\text{F}$	25V	$\leq 9\%$	0402 $\geq 47\text{nF}$, 0805 $\geq 0.47\mu\text{F}$	$\leq 12.5\%$	121 /10 μF	16V	$\leq 9\%$	0402 $\geq 0.068\mu\text{F}$, 0603 $\geq 0.68\mu\text{F}$	16V ($\geq 1\mu\text{F}$)	$\leq 12.5\%$	0603 $\geq 2.2\mu\text{F}$,0805 $\geq 3.3\mu\text{F}$, 1206 $\geq 10\mu\text{F}$,1210 $\geq 22\mu\text{F}$, 1812 $\geq 47\mu\text{F}$,	<p>NPO: C $< 30\text{pF}$: Q value $\geq 400+20\text{C}$ C $\geq 30\text{pF}$: Q value ≥ 1000</p> <p>X7R/ X5R : Vr=50V~6KV, DF$\leq 2.5\%$ Vr=25V, DF$\leq 3.5\%$ Vr=16V, DF$\leq 3.5\%$ Vr=10V, DF$\leq 5.0\%$ Vr=6.3V, DF$\leq 10.0\%$</p> <p>Y5V: Vr$\geq 50\text{V}$, DF$\leq 5.0\%$ Vr =25V, DF$\leq 7.0\%$ Vr=16V(C $< 1.0\mu\text{F}$), DF$\leq 7.0\%$ Vr=16V(C $\geq 1.0\mu\text{F}$), DF$\leq 9.0\%$ Vr=10V, DF$\leq 12.5\%$ Vr=6.3V, DF$\leq 20\%$</p> <p style="color: red;">(see EXCEPTION at left side)</p>
r	D.F	Exc ption of D.F.																																							
\geq 50V	$\leq 3.5\%$	0603 $\geq 47\text{nF}$, 0805 $\geq 0.18\mu\text{F}$, 1206 $\geq 0.47\mu\text{F}$, 1210 $\geq 1.0\mu\text{F}$																																							
25V	$\leq 5\%$	0805 $\geq 1.0\mu\text{F}$, 1210 $\geq 10\mu\text{F}$																																							
	$\leq 7\%$	0603 $\geq 0.33\mu\text{F}$, 1206 $\geq 4.7\mu\text{F}$																																							
	$\leq 10\%$	0603 $\geq 0.47\mu\text{F}$,0805 $\geq 2.2\mu\text{F}$ 1206 $\geq 6.8\mu\text{F}$,0402 $\geq 0.1\mu\text{F}$																																							
16V	$\leq 5\%$	0402 $\geq 33\text{nF}$, 0603 $\geq 0.15\mu\text{F}$ 0805 $\geq 0.68\mu\text{F}$, 1206 $\geq 2.2\mu\text{F}$, 1210 $\geq 4.7\mu\text{F}$,																																							
	$\leq 10\%$	0603 $\geq 0.68\mu\text{F}$, 0805 $\geq 2.2\mu\text{F}$, 1206 $\geq 4.7\mu\text{F}$, 1210 $\geq 22\mu\text{F}$,																																							
10V	$\leq 10\%$	0402&0603 $\geq 0.33\mu\text{F}$,0805 $\geq 2.2\mu\text{F}$, 1206 $\geq 2.2\mu\text{F}$, 1210 $\geq 22\mu\text{F}$																																							
Vr	D.F	Exception o .F.																																							
$\geq 50\text{V}$	$\leq 7\%$	0603 $\geq 0.1\mu\text{F}$, 0805 $\geq 0.47\mu\text{F}$, 1206 $\geq 4.7\mu\text{F}$																																							
25V	$\leq 9\%$	0402 $\geq 47\text{nF}$, 0805 $\geq 0.47\mu\text{F}$																																							
	$\leq 12.5\%$	121 /10 μF																																							
16V	$\leq 9\%$	0402 $\geq 0.068\mu\text{F}$, 0603 $\geq 0.68\mu\text{F}$																																							
16V ($\geq 1\mu\text{F}$)	$\leq 12.5\%$	0603 $\geq 2.2\mu\text{F}$,0805 $\geq 3.3\mu\text{F}$, 1206 $\geq 10\mu\text{F}$,1210 $\geq 22\mu\text{F}$, 1812 $\geq 47\mu\text{F}$,																																							
3	Insulation Resistance	<p>Rated voltage $\leq 100\text{V}$: Apply RV for 120 sec.</p> <p>Rated voltage 200-630V : Apply RV for 60 sec.</p> <p>Rated voltage 1KV-6KV : Apply 500V fo 60 sec.</p>	<p>NPO : $\geq 10\text{G}\Omega$ or 500Ω-F(whichever is smaller)</p> <p>X7R/X5R, Y5V : $\geq 10\text{G}\Omega$ or 100Ω-F(whichever is smaller)</p>																																						
4	Dielectric Strength	<p>Test voltage(Vt): (Duration 1~5 seconds.)</p> <p>Vt= Vr X250% (Vr$\leq 100\text{V}$) Charge current: $\leq 50\text{mA}$</p> <p>Vt= Vr X200% For product Vr=200V/250V</p> <p>Vt= Vr X150% For product Vr=500V~999V</p> <p>Vt= Vr X120% For product Vr=1KV~3KV</p> <p>Vt= Vr X110% For Vr$\leq 5\text{KV}$, Vt= Vr X100% For Vr$> 5\text{KV}$</p>	<p>No evidence of damage or flash over d ring test.</p>																																						
5	Solderability	<p>*Solder temperature : 235\pm5°C</p> <p>*Dipping time : 2\pm0.5 sec.</p>	<p>95% min. c verage of all metalized area</p>																																						

SPECIFICATIONS AND TEST METHODS

No	Item	Test Method	Specification			
6	Vibration Resistance	*Vibration Frequency: 10 – 55 Hz.min. *Total amplitude: 1.5mm *Test Time: 6 hrs (Two hrs each in three mutually perpendicular direction)	No remarkable damage Cap. Change and Q/D.F.: To meet initial spec.			
7	Resistance to Soldering Heat	Preheat the capacitor at 120~150°C for 1min. Have the capacitor dip into the solder bath at 270±5°C for 10±1 sec. Set it at room temperature for 48±4hrs, then measure. ■ Initial measurement for X7R/X5R and Y5V. Perform a heat treatment at 150±5°C for 1 hr and then set for 48±4 hrs at room temperature then measure.	Dielectric	NPO	X7R/X5R	Y5V
			Appearance	No defect		
			Capacitance change	<±2.5% or±0.25 pf	±7.5%	±20%
			DF(or Q)	C ≥ 30pf : Q ≥ 1000 C < 30pf : Q ≥ 4 0+20C	Same as no.2	Same as no.2
			I.R	More than 10GΩ or 500ΩF (Whichever is Smaller)		
			Dielectric Strength	No failure		
8	Adhesive Strength of Termination	*Pressurizing force: 5N(≤0603) and 10n(>0603) *Test time: 10 ± 1 sec.	No remarkable damage or removal of the termination.			
9	High temperature Load	*Test Temp. : NPO, X7R : 125±3°C X5R, Y5V : 85±3°C *Test Voltage: (1) V < 500V : 2 X R.V. (2) 500 ≤ V < 1000V : 1.5 X R.V. (3) V = 1000V ~ 3000V : 1.2 X R.V. (4) V > 3000V : 100% of R.V. *Test Time: 1000 hrs *Measurement to be made after keeping at room temp. for 48± hr.	Dielectric	N O	X7R/X R	Y5V
			Appearance	No defect		
			Capacitance change	<±3% or±0.3 pF whichever is larger	≥ 10V: ±12.5% 6.3V : ±25%	±30%
			DF(or Q)	SAME AS NO. 2		
			I.R.	≥ 10V, ≥ 1GΩ or 50Ω-F (whichever is smaller) 6.3V: ≥ 10Ω-F		
			Dielectric strength	No failure		

SPECIFICATIONS AND TEST METHODS

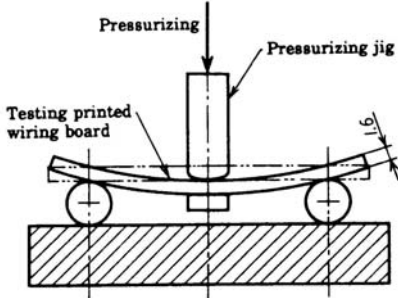
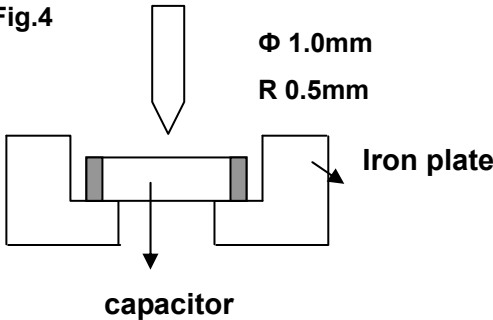
No	Item	Test Method	Specification														
10	Temperature Coefficient	<p>(a) NPO The temperature coefficient is determined using the capacitance measured in step 3 as a reference. When cycling the temperature sequentially from step 1 through 5. The capacitance shall be within the specified tolerance for the temperature coefficient.</p> <table border="1"> <thead> <tr> <th>Step</th> <th>Temperature(°C)</th> </tr> </thead> <tbody> <tr> <td>1</td> <td>+25±2°C</td> </tr> <tr> <td>2</td> <td>-55±3°C</td> </tr> <tr> <td>3</td> <td>+25±2°C</td> </tr> <tr> <td>4</td> <td>+125±3°C(for NPO/X7R +85 ± 3°C(for X5R/Y5V))</td> </tr> <tr> <td>5</td> <td>+25±2°C</td> </tr> </tbody> </table> <p>(b) X7R/X5R,Y5V The ranges of capacitance change compared with the 25±2°C value over the temperature range shall be within the specified ranges</p>	Step	Temperature(°C)	1	+25±2°C	2	-55±3°C	3	+25±2°C	4	+125±3°C(for NPO/X7R +85 ± 3°C(for X5R/Y5V))	5	+25±2°C	Dielectric	Temperature Range	Capacitance Change
			Step	Temperature(°C)													
			1	+25±2°C													
			2	-55±3°C													
			3	+25±2°C													
4	+125±3°C(for NPO/X7R +85 ± 3°C(for X5R/Y5V))																
5	+25±2°C																
NPO	-55°C to +125°C	0±30ppm/°C															
X7R	-55°C to +125°C	Within ±15%															
X5R	-55°C to +85°C	Within ±15%															
Y5V	-25°C to +85°C	Within +30%~-80%															
11	Resistance to board bending	<p>Mount the capacitor to the testing printed wiring board. Then apply force in the direction shown in Fig.3. The bending stroke shall be more than 1mm, Pressurizing is carried out at the rate of 1mm/s. After reaching the specified bending, keeping it for 5±1 seconds then measure the capacitance value.</p> <p>Cap. Change : NPO: ±5% or ±0.5 pF whichever is larger X7R, X5R: ±12.5% Y5V: ±30%</p> <p>(This capacitance change means the change of capacitance under specified flexure of substrate from the capacitance measured before the test)</p>	<p>No cracking or marking defects shall occur Fig.3</p> <p>Unit: mm</p> 														
12	Chip Break Strength	<p>Place the capacitor on an iron plate, And then gradually apply a load on the center of the chip until it breaks.</p> <p>Tip of push-pull gauge is shown in Fig.4</p>	<p>To load 2 kgf at least.</p> <p>Fig.4</p>  <p>Φ 1.0mm R 0.5mm</p> <p>Iron plate</p> <p>capacitor</p>														

SPECIFICATIONS AND TEST METHODS

No	Item	Test Method	Specification																												
13	Temperature cycle	<p>Mount the capacitor on test board, then cycling the temperature sequentially from step 1 to step 5, and perform 25 cycles.</p> <table border="1"> <thead> <tr> <th rowspan="2">Step.</th> <th>NPO</th> <th>X7R</th> <th>X5R/Y5V</th> </tr> <tr> <th colspan="2">Temperature (°C) /time(min)</th> <th>Temperature(°C) /time(min)</th> </tr> </thead> <tbody> <tr> <td>1</td> <td colspan="2">+25±2°C / 3±1</td> <td>+25±2°C / 3±1</td> </tr> <tr> <td>2</td> <td colspan="2">-55±2°C / 30±3</td> <td>-30±2°C / 30±3</td> </tr> <tr> <td>3</td> <td colspan="2">+25±2°C / 3±1</td> <td>+25±2°C / 3±1</td> </tr> <tr> <td>4</td> <td colspan="2">+125±3°C / 30±3</td> <td>+85±3°C / 30±3</td> </tr> <tr> <td>5</td> <td colspan="2">+25±2°C / 3±1</td> <td>+25±2°C / 3±1</td> </tr> </tbody> </table> <p>Remove and let sit for 24±2hours(NPO) or 48±4hours(X7R/X5R,Y5V) at room temperature, then measure</p>	Step.	NPO	X7R	X5R/Y5V	Temperature (°C) /time(min)		Temperature(°C) /time(min)	1	+25±2°C / 3±1		+25±2°C / 3±1	2	-55±2°C / 30±3		-30±2°C / 30±3	3	+25±2°C / 3±1		+25±2°C / 3±1	4	+125±3°C / 30±3		+85±3°C / 30±3	5	+25±2°C / 3±1		+25±2°C / 3±1	<p>*No remarkable damage.</p> <p>*Cap. Change : NPO: ±2.5% or ±0.5 pF whichever is larger</p> <p>X7R, X5R: ±7.5%</p> <p>Y5V: ±20%</p> <p>*Q/D.F..I.R & dielectric strength : To meet initial requirement.</p>	
Step.	NPO	X7R		X5R/Y5V																											
	Temperature (°C) /time(min)		Temperature(°C) /time(min)																												
1	+25±2°C / 3±1		+25±2°C / 3±1																												
2	-55±2°C / 30±3		-30±2°C / 30±3																												
3	+25±2°C / 3±1		+25±2°C / 3±1																												
4	+125±3°C / 30±3		+85±3°C / 30±3																												
5	+25±2°C / 3±1		+25±2°C / 3±1																												
14	Humidity (Damp Heat) Steady State	<p>*Test temp.: 40±2°C</p> <p>*Humidity: 90~95% RH</p> <p>*Test time: 500 hrs</p> <p>*Measurement to be made after keeping at room temperature for 48±4 hrs.</p> <p style="text-align: center;">EXCEPTION OF D.F.</p> <p>X7R/X5R:</p> <table border="1"> <thead> <tr> <th>Vr</th> <th>D.F</th> <th>Exception of D.F.</th> </tr> </thead> <tbody> <tr> <td>≥ 50V</td> <td>≤ 6%</td> <td>0603 ≥ 47nF, 0805 ≥ 0.18uF, 1206 ≥ 0.47uF, 1210 ≥ 1.0uF</td> </tr> <tr> <td rowspan="2">25V</td> <td>≤ 10%</td> <td>0805 ≥ 1.0uF, C ≥ 4.7Uf</td> </tr> <tr> <td>≤ 14%</td> <td>0603 ≥ 0.33uF</td> </tr> <tr> <td>16V</td> <td>≤ 10%</td> <td>0402 ≥ 33nF, 0603 ≥ 0.15uF, 0805 ≥ 0.68uF, C ≥ 2.2uF</td> </tr> <tr> <td>10V</td> <td>≤ 15%</td> <td>0402 ≥ 56nF, 0603 ≥ 0.33uF, C ≥ 2.2uF</td> </tr> </tbody> </table> <p>Y5V:</p> <table border="1"> <thead> <tr> <th>Vr</th> <th>D.F</th> <th>Exception of D.F.</th> </tr> </thead> <tbody> <tr> <td rowspan="2">25V</td> <td>≤ 10%</td> <td>0603 ≥ 0.1uF, 0805 ≥ 0.33uF</td> </tr> <tr> <td>≤ 12.5%</td> <td>0402 ≥ 0.047uF</td> </tr> <tr> <td>16V</td> <td>≤ 12.5%</td> <td>0402 ≥ 0.047uF</td> </tr> </tbody> </table>	Vr	D.F	Exception of D.F.	≥ 50V	≤ 6%	0603 ≥ 47nF, 0805 ≥ 0.18uF, 1206 ≥ 0.47uF, 1210 ≥ 1.0uF	25V	≤ 10%	0805 ≥ 1.0uF, C ≥ 4.7Uf	≤ 14%	0603 ≥ 0.33uF	16V	≤ 10%	0402 ≥ 33nF, 0603 ≥ 0.15uF, 0805 ≥ 0.68uF, C ≥ 2.2uF	10V	≤ 15%	0402 ≥ 56nF, 0603 ≥ 0.33uF, C ≥ 2.2uF	Vr	D.F	Exception of D.F.	25V	≤ 10%	0603 ≥ 0.1uF, 0805 ≥ 0.33uF	≤ 12.5%	0402 ≥ 0.047uF	16V	≤ 12.5%	0402 ≥ 0.047uF	<p>*No remarkable damage</p> <p>*Cap. Change : NPO: ±5% or ±0.5 pF whichever is larger X7R/X5R: ≥ 10V: ±12.5%, 6.3V : ±25% Y5V: ±30%</p> <p>*Q value/D.F. NPO : C ≥ 30pf : Q ≥ 350 10pf ≤ Cap < 30pF, Q ≥ 275+2.5C Cap < 10pF, Q ≥ 200+10C X7R, X5R : Vr ≥ 50V, D.F. ≤ 3% Vr=16/25V, D.F. ≤ 5% Vr=10V, D.F. ≤ 7.5% Y5V : Vr ≥ 25/50V, D.F. ≤ 7.5% Vr=16V(C < 1.0uF),DF ≤ 10% Vr=16V(C ≥ 1.0uF),DF ≤ 12.5% Vr=10V, D.F. ≤ 15% Vr=6.3V, D.F. ≤ 30% (See EXCEPTION at left side) ≥ 10V, ≥ 1GΩ or 50Ω-F (whichever is smaller) 6.3V: ≥ 10Ω-F</p>
Vr	D.F	Exception of D.F.																													
≥ 50V	≤ 6%	0603 ≥ 47nF, 0805 ≥ 0.18uF, 1206 ≥ 0.47uF, 1210 ≥ 1.0uF																													
25V	≤ 10%	0805 ≥ 1.0uF, C ≥ 4.7Uf																													
	≤ 14%	0603 ≥ 0.33uF																													
16V	≤ 10%	0402 ≥ 33nF, 0603 ≥ 0.15uF, 0805 ≥ 0.68uF, C ≥ 2.2uF																													
10V	≤ 15%	0402 ≥ 56nF, 0603 ≥ 0.33uF, C ≥ 2.2uF																													
Vr	D.F	Exception of D.F.																													
25V	≤ 10%	0603 ≥ 0.1uF, 0805 ≥ 0.33uF																													
	≤ 12.5%	0402 ≥ 0.047uF																													
16V	≤ 12.5%	0402 ≥ 0.047uF																													
14	Humidity (Damp Heat) Load	<p>*Test temp.: 40±2°C</p> <p>*Humidity: 90~95% RH</p> <p>*Test time: 500 hrs</p> <p>*Test Voltage : Rated Voltage (Max 500V)</p> <p>*Measurement to be made after keeping at room temperature for 48±4 hrs.</p>	<p>*No remarkable damage</p> <p>*Cap. Change : NPO: ±7.5% or ±0.75 pF whichever is larger X7R/X5R: ≥ 10V: ±12.5%, 6.3V : ±25% Y5V: ±30%</p> <p>*Q value/D.F. SAME AS No. 13</p>																												

8.Packing

8-1. Bulk Packaging: Packing code(B)

8-2. Tape Packing: please specify the packing code when ordering.

Packing code	Pcs/Reel	Reel size	
05	500	7"	
1	1000	7"	
2	2000	7"	
3	3000	7"	
T	4000	7"	
U	10000	0402	7"
		0603	10"
V	15000	13"	
W	20000	13"	

8-3. Appearance of taping

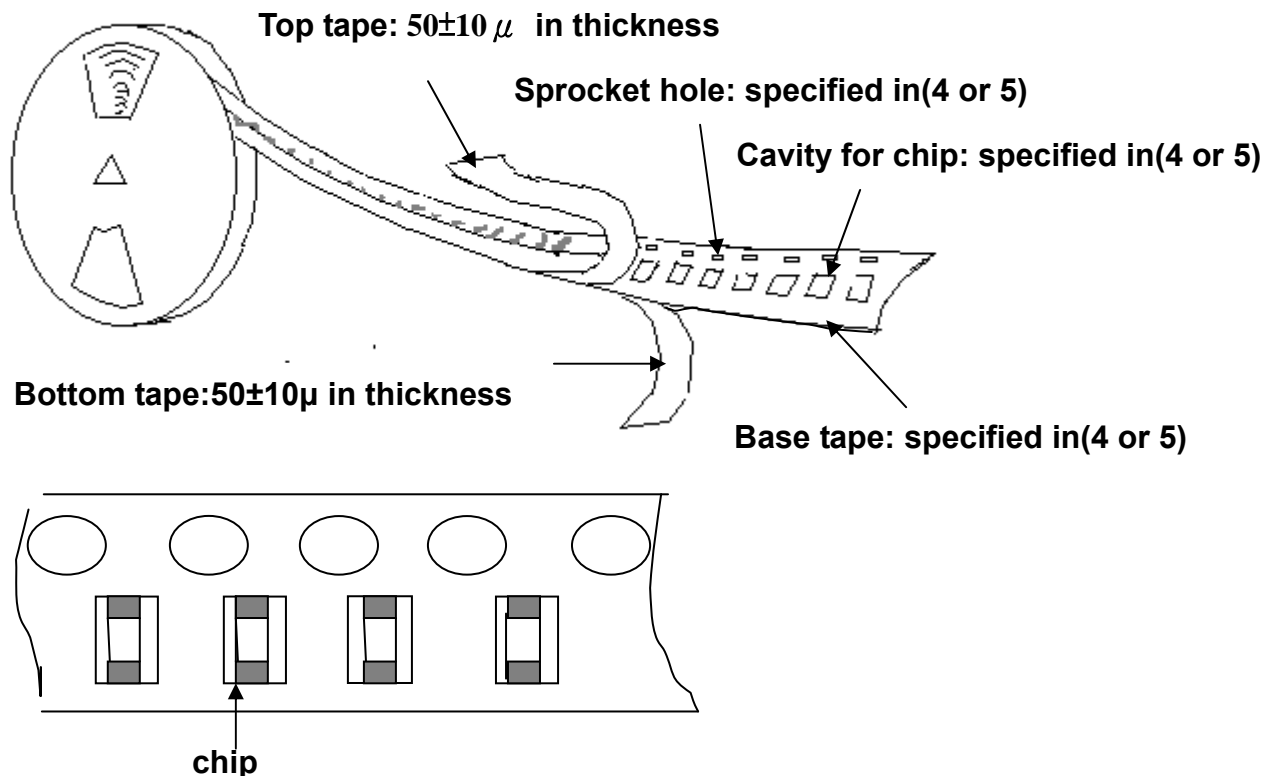

8-4 Dimensions of Paper Tape

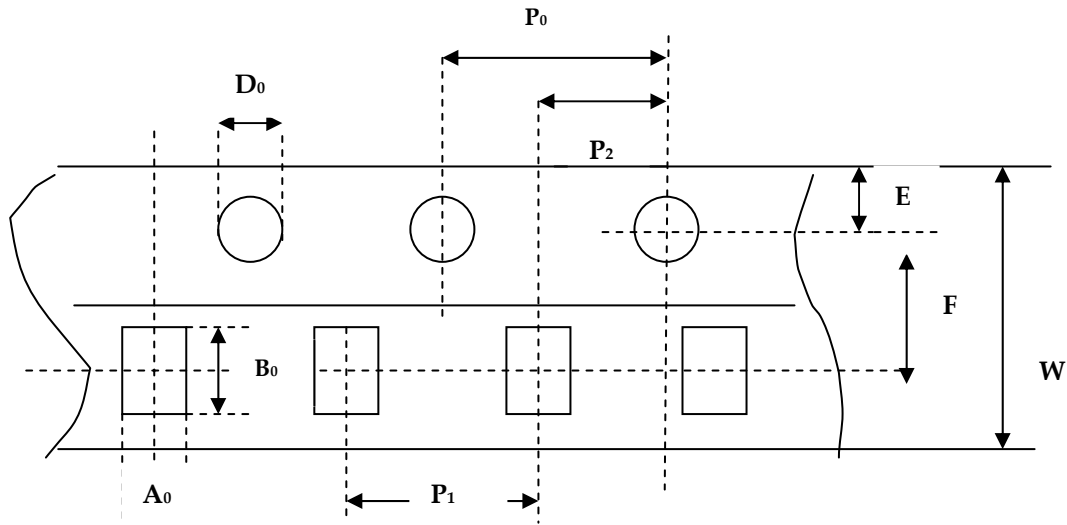

Unit: m/m

Chip size	0402	0603	0805	1206	Tolerance
Mark					
A₀	0.61	1.02	1.50	2.00	±0.1
B₀	1.10	1.82	2.30	3.50	±0.1
W	8.0	8.0	8.0	8.0	±0.3
E	1.75	1.75	1.75	1.75	±0.1
F	3.5	3.5	3.5	3.5	±0.05
D₀	1.55	1.55	1.55	1.55	±0.1
P₁	2.0	4.0	4.0	4.0	±0.05
P₂	2.0	2.0	2.0	2.0	±0.05
P₀	4.0	4.0	4.0	4.0	±0.05

Paper thickness: T:0.65±0.05 mm (for 0402 product)
T:0.75±0.05 mm (for thickness code S)
T:0.95±0.05 mm (for thickness code P, H)

- Note:** (1) The top tape and bottom tape shall not protrude beyond the edges of the tape, and shall not cover sprocket holes.
(2) Cumulative tolerance of sprocket holes 10 pitch : ±0.3mm

8-5 Dimensions of Embossed Packing (plastic tape):

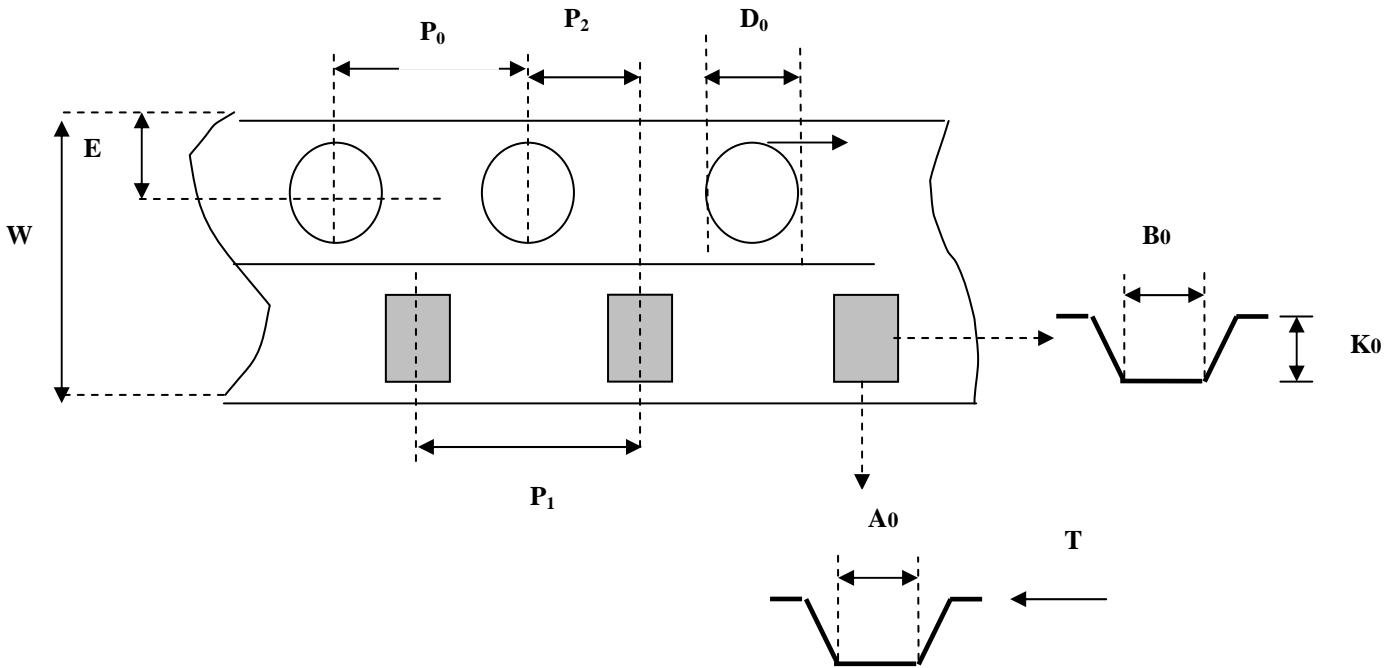

unit: m/m

Chip size	0805	1206	1210	1808	1812	1825	2220	2225
Mark								
A₀	1.65±0.2	2.00±0.2	2.80±0.2	2.40±0.2	3.60±0.2	<6.80	5.50±0.3	<6.80
B₀	2.40±0.2	3.60±0.2	3.60±0.2	4.90±0.3	4.90±0.3	<5.30	6.20±0.3	<6.50
K₀	2.50 max	2.50 max	3.00 max	2.50 max	4.0 max	<3.10	4.0 max	<3.10
D₀	1.55±0.1	1.55±0.1	1.55±0.1	1.55±0.1	1.55±0.1	1.50+0.10/-0	1.55±0.1	1.50+0.10/-0
W	8.00±0.2	8.0±0.2	8.0±0.2	12.0±0.2	12.0±0.2	12.0±0.20	12.0±0.2	12.0±0.20
P₁	4.00±0.1	4.00±0.1	4.00±0.1	4.00±0.1	8.00±0.1	8.00±0.10	8.0±0.1	8.00±0.10
P₂	2.00±0.1	2.00±0.1	2.00±0.1	2.00±0.1	2.00±0.1	2.00±0.05	2.0±0.1	2.00±0.05
E	1.75±0.1	1.75±0.1	1.75±0.1	1.75±0.1	1.75±0.1	1.75±0.10	1.75±0.1	1.75±0.10
T	0.23±0.05	0.23±0.05	0.23±0.05	0.23±0.05	0.25±0.1	0.30±0.10	0.25±0.1	0.30±0.10
P₀	4.00±0.1	4.00±0.1	4.00±0.1	4.00±0.1	4.00±0.1	4.00±0.10	4.00±0.1	4.00±0.10

Emboss tape: for thickness code X, L, Z, G, U

8-6. Dimension of Reel.

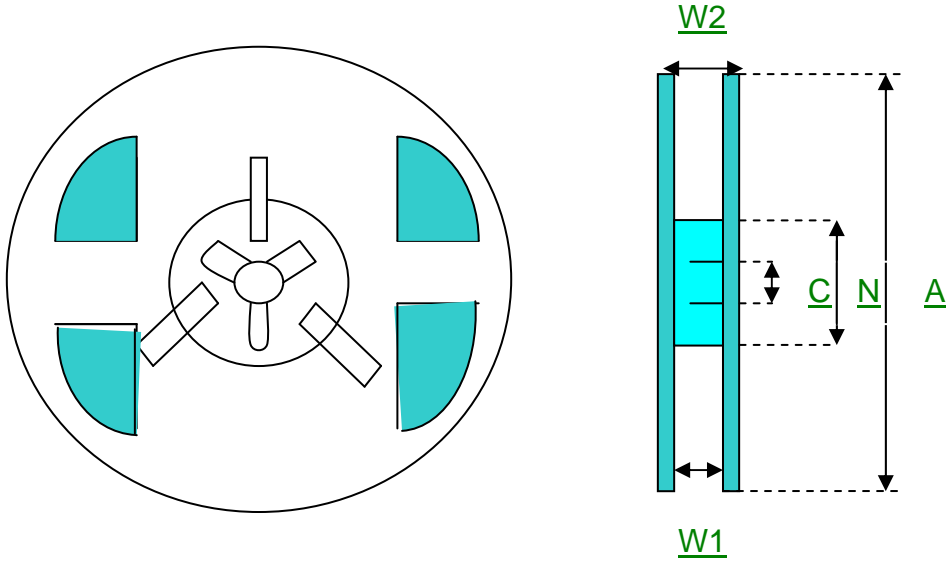

unit: m/m

Reel size	A	N	C	W1	W2(max.)
7" 0402~1210	178 ±0.5	60.5±1.0	13.0+0.5/-0.2	8.4+1.5/-0	14.4
7" 1812~2225	178 ±0.5	60.5±1.0	13.0+0.5/-0.2	12.4+2.0/-0	16.0
10"	250 ±0.5	100 ±1.0	13.0+0.5/-0.2	8.4+1.5/-0	14.4
13"	330 ±0.5	100 ±1.0	13.0+0.5/-0.2	8.4+1.5/-0	14.4

9.Soldering & Cleaning

Recommended Soldering Profile (Prevention of thermal shock)

Figure.(I) IR reflow soldering profile for SMT process with SnAgCu series solder paste , (lead free type)

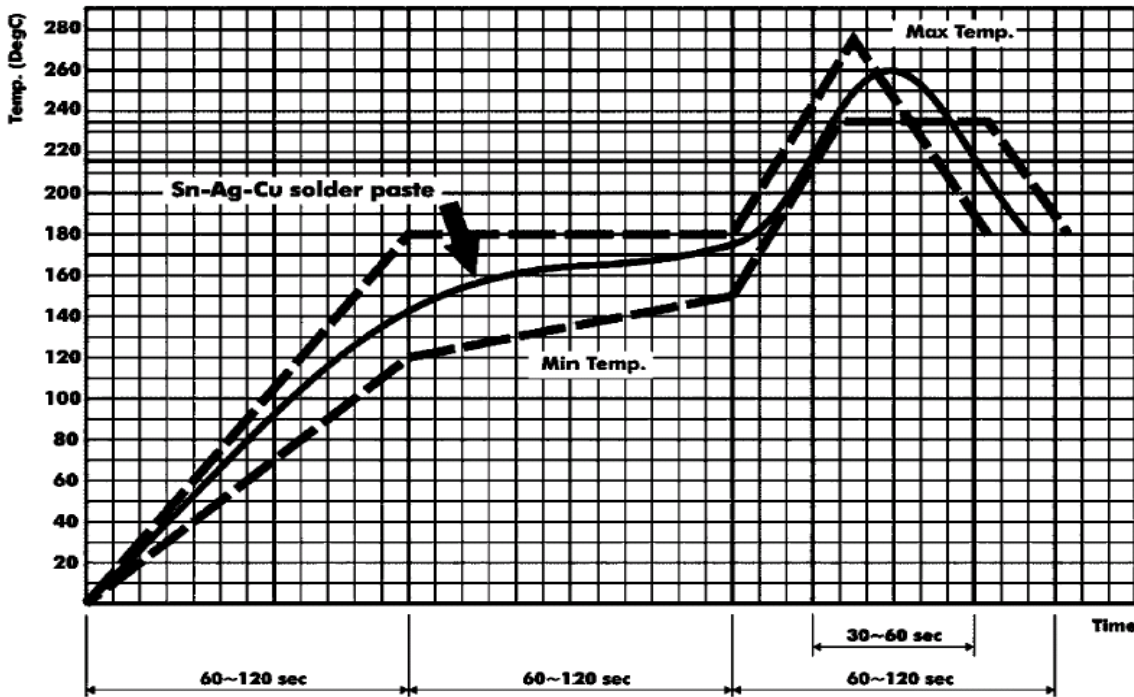
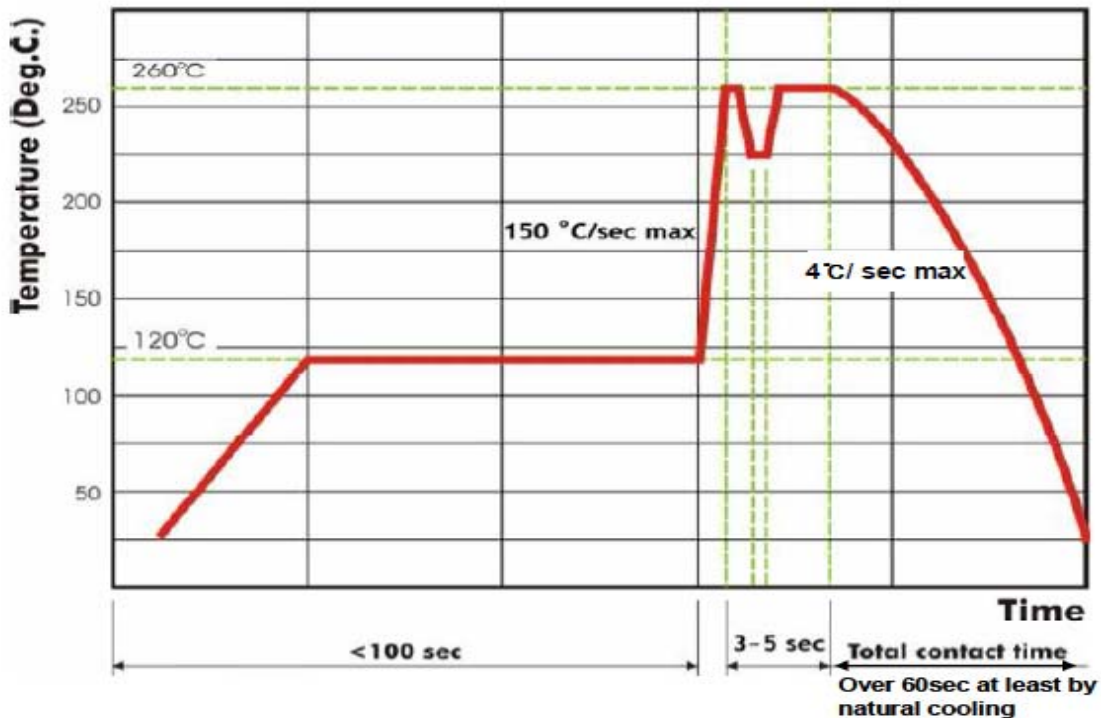

Figure. (II) Wave soldering profile for SMT process with SnAgCu series solder paste, (lead free type)
wave soldering is recommended only for the following size:
 0603(1608), 0805(2012) and 1206(3216) thickness < 1mm



Cleaning :

All flux residues must be removed by using suitable electronic-grade vapor-cleaning solvents to eliminate contamination that could cause electrolytic surface corrosion. Goods results can be obtained by using ultrasonic cleaning of solvent. The choice of the proper system is depends upon many factors such as component mix, flux, and solder paste and assembly method. The ability of the cleaning system to remove flux residues and contamination from under the chips is very important.

10.Storage

1. To store products at +5 to 40°C ambient temperature and 40 to 60% related humidity conditions.(refer to JIS C 0806)
2. Although HITANO MLCC officially stated storage and shelf life is 2 years from the manufacturing date, we recommend using the products within six months of receipt. Check solder ability in case of shelf life extension is needed.
3. Please note that these are "recommended" storage conditions and parts can be stored outside these parameters without affecting solderability or short term reliability. However, components not stored as recommended may see issues such as solderability and tape and reel degradation where the paper tape may not separate as designed.

Caution:

- A. Don't store products in a corrosive environment such as sulfide, chloride gas, or acid. It may cause oxidization of electrode, which easily be resulted in poor soldering.
- B. To store products on the shelf and avoid exposure to moisture.
- C. Don't expose products to excessive shock, vibration, direct sunlight and so on.

11 Label

Company logo

Commodity

HITANO

CHIP CAPACITORS

Part No: 0805B104K500NT



HITANO part no. (Bar Code 128)

Q'TY.: 4000 pcs



Q'ty of the reel (Bar code 128)

Lot No: 60AS5AP18



Logo of Rohs compliant

Cust P/N:

2006/10/13
MADE IN TAIWAN

Date code

Lot No. Customer part no. (If any)

12. PCB design

Chip components are susceptible to board stress since the component itself is mounted directly on the board. They are also sensitive to mechanical and thermal stress when solder, which may cause chip cracked.

Please take solder form and component layout into consideration to eliminate stress.

12.1. Pattern form

(1) Placing of chip components and component.

incorrect

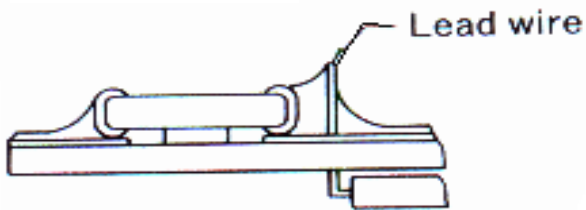

correct

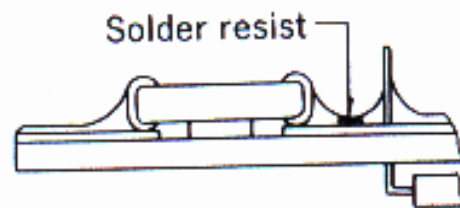

(2) Placing close to chassis.

incorrect

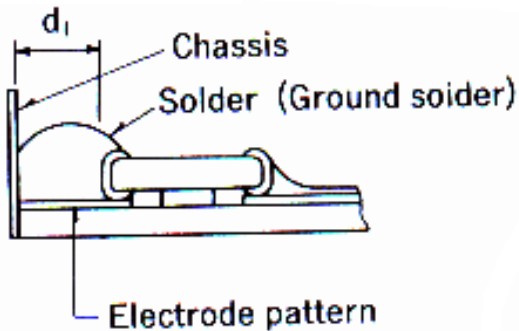

correct

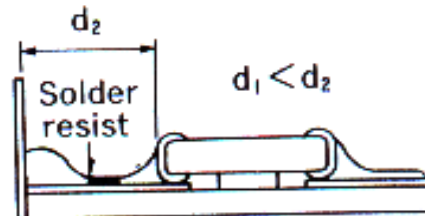

(3) Placing leaded components after chip component.

incorrect

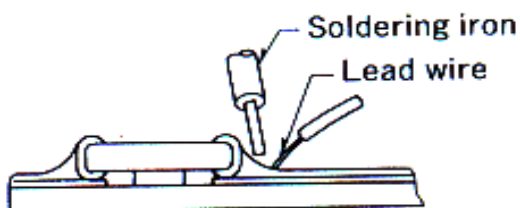

correct

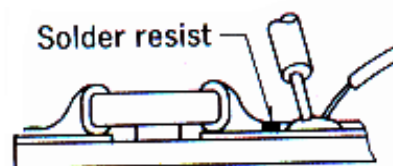

(4) Lateral mounting

incorrect

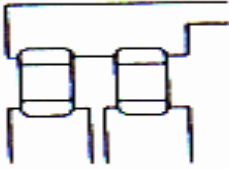

correct

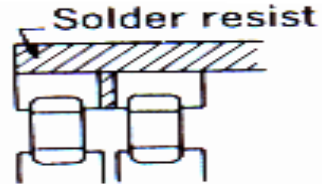

12-2. Component direction

To design a mounting position that minimizes the stress imposed on the chip during flexing or bending of the board.

(1) put the component lateral to the direction in which stress acts.

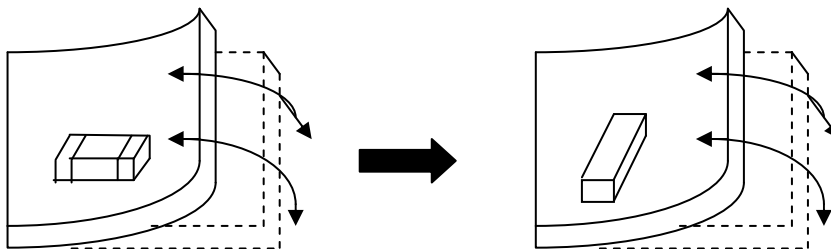

(2) Component layout close to board separation point.
Susceptibility to stress in the order: $A > C > B = D$

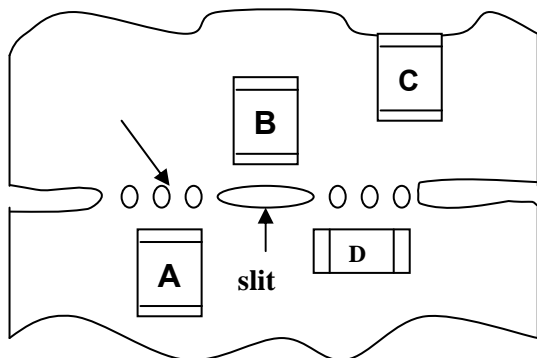

12.3. Land Pattern

When capacitors are mounted on P.C. board, the amount of solder directly affect the performance of capacitors. Therefore, the following items should be carefully considered in the design of solder land pattern.

- (1) The greater the amount of solder, the higher the stress on the chip capacitors, and lead to cracking and breaking likely. It is necessary the appropriate size and configuration of the solder pads should be designed to have proper amount of solder on the termination.
- (2) When two or more capacitors are soldered together onto the same land or pad, the pad must be designed so that each capacitor's soldering point is separated by solder-resist.

The following diagram and table for recommended pad dimensions.

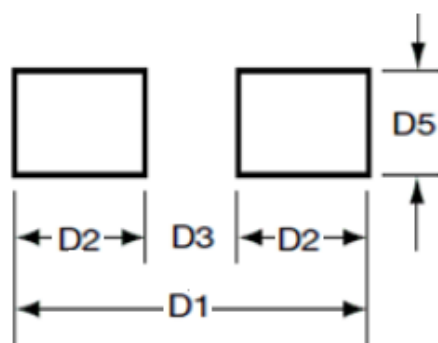

Dimensions in millimeters

Type	0201	0402	0603	0805	1206	1210	1808	1812	1825	2220	2225
D1	0.65	1.50	2.30	2.80	4.00	4.00	5.40	5.30	5.30	7.00	7.00
D2	0.21	0.50	0.80	0.90	0.90	0.90	1.05	0.90	0.90	1.35	1.35
D3	0.23	0.50	0.70	1.00	2.20	2.20	3.30	3.50	3.50	4.30	4.30
D5	0.30	0.50	0.80	1.30	1.60	2.50	2.30	3.80	6.50	5.00	6.50

Unit: mm