

Configuring Manual Edition 04/2007

**1FT7 synchronous motors
SINAMICS S120**

sinamics

SIEMENS

SIEMENS

SINAMICS S120

1FT7 Synchronous Motors

Configuration Manual

Preface

Motor description

1

Use

2

Mechanical data

3

Electrical data

4

Engineering software

5

Motor components

6

Technical data and characteristic curves

7

Dimension drawings



8

Appendix

A

Safety Guidelines

This manual contains notices you have to observe in order to ensure your personal safety, as well as to prevent damage to property. The notices referring to your personal safety are highlighted in the manual by a safety alert symbol, notices referring only to property damage have no safety alert symbol. These notices shown below are graded according to the degree of danger.

 Danger
indicates that death or severe personal injury will result if proper precautions are not taken.
 Warning
indicates that death or severe personal injury may result if proper precautions are not taken.
 Caution
with a safety alert symbol, indicates that minor personal injury can result if proper precautions are not taken.
Caution
without a safety alert symbol, indicates that property damage can result if proper precautions are not taken.
Notice
indicates that an unintended result or situation can occur if the corresponding information is not taken into account.

If more than one degree of danger is present, the warning notice representing the highest degree of danger will be used. A notice warning of injury to persons with a safety alert symbol may also include a warning relating to property damage.

Qualified Personnel

The device/system may only be set up and used in conjunction with this documentation. Commissioning and operation of a device/system may only be performed by **qualified personnel**. Within the context of the safety notes in this documentation qualified persons are defined as persons who are authorized to commission, ground and label devices, systems and circuits in accordance with established safety practices and standards.

Prescribed Usage

Note the following:

 Warning
This device may only be used for the applications described in the catalog or the technical description and only in connection with devices or components from other manufacturers which have been approved or recommended by Siemens. Correct, reliable operation of the product requires proper transport, storage, positioning and assembly as well as careful operation and maintenance.

Trademarks

All names identified by ® are registered trademarks of the Siemens AG. The remaining trademarks in this publication may be trademarks whose use by third parties for their own purposes could violate the rights of the owner.

Disclaimer of Liability

We have reviewed the contents of this publication to ensure consistency with the hardware and software described. Since variance cannot be precluded entirely, we cannot guarantee full consistency. However, the information in this publication is reviewed regularly and any necessary corrections are included in subsequent editions.

Preface

Information on the documentation

You will find an overview of the documentation, which is updated on a monthly basis, in the available languages on the Internet under:

<http://www.siemens.com/motioncontrol>

Select the menu items "Support" → "Technical Documentation" → "Overview of Publications".

The Internet version of DOConCD (DOConWEB) is available at:

<http://www.automation.siemens.com/doconweb>

Information on the range of training courses and FAQs (frequently asked questions) are available on the Internet under:

<http://www.siemens.com/motioncontrol> under menu option "Support"

Target group

Planners and project engineers

Benefits

The Configuration Manual supports you when selecting motors, calculating the drive components, selecting the required accessories as well as when selecting line and motor-side power options.

Standard scope

The scope of the functionality described in this document can differ from the scope of the functionality of the drive system that is actually supplied. Other functions not described in this documentation might be able to be executed in the drive system. This does not, however, represent an obligation to supply such functions with a new control or when servicing. Extensions or changes made by the machine manufacturer are documented by the machine manufacturer.

For the sake of simplicity, this documentation does not contain all detailed information about all types of the product and cannot cover every conceivable case of installation, operation, or maintenance.

Technical Support

If you have any technical questions, please contact our hotline:

	Europe / Africa	Asia / Australia	America
Phone	+49 (0) 180 5050 – 222	+86 1064 719 990	+1 423 262 2522
Fax	+49 (0) 180 5050 – 223	+86 1064 747 474	+1 423 262 2289
Internet	http://www.siemens.com/automation/support-request		
E-mail	mailto:adsupport@siemens.com		

Note

For technical support telephone numbers for different countries, go to:
<http://www.siemens.com/automation/service&support>

Questions about the documentation

If you have any questions (suggestions, corrections) regarding this documentation, please fax or e-mail us at:

Fax	+49 9131 98 63315
E-mail	E-mail to: docu.motioncontrol@siemens.com

A fax form is available in the appendix of this document.

Internet address for SINAMICS

<http://www.siemens.com/sinamics>

EC Declaration of Conformity

The EC Declaration of Conformity for the EMC Directive can be found/obtained in the Internet:

<http://www.support.automation.siemens.com>

under the Product/Order No. 15257461 at the relevant branch office of the A&D MC Division of Siemens AG.

Disposal

Motors must be disposed of carefully taking into account domestic and local regulations in the normal recycling process or by returning to the manufacturer.

The following must be taken into account when disposing of the motor:

- Oil according to the regulations for disposing of old oil
- Not mixed with solvents, cold cleaning agents or remains of paint
- Components that are to be recycled should be separated according to:
 - Electronics waste (e.g. sensor electronics, sensor modules)
 - Iron to be recycled
 - Aluminum
 - Non-ferrous metal (gearwheels, motor windings)

Danger and warning information

 Danger
<p>Start-up/commissioning is absolutely prohibited until it has been completely ensured that the machine, in which the components described here are to be installed, is in full compliance with the specifications of Directive 98/37/EC.</p> <p>Only appropriately qualified personnel may commission/start-up the SINAMICS units and the motors.</p> <p>This personnel must carefully observe the technical customer documentation associated with this product and be knowledgeable about and carefully observe the danger and warning information.</p> <p>Operational electrical equipment and motors have parts and components which are at hazardous voltage levels.</p> <p>When the machine or system is operated, hazardous axis movements can occur.</p> <p>All of the work carried-out on the electrical machine or system must be carried-out with it in a no-voltage condition.</p> <p>SINAMICS units are generally designed for operation on low-resistance, grounded power supply networks (TN systems). For additional information please refer to the appropriate documentation for the drive converter systems.</p>

 Warning
<p>The successful and safe operation of this equipment and motors is dependent on professional transport, storage, installation and mounting as well as careful operator control, service and maintenance.</p> <p>For special versions of the drive units and motors, information and data in the catalogs and quotations additionally apply.</p> <p>In addition to the danger and warning notices in the technical customer documentation supplied, the applicable national, local and plant-specific regulations and requirements must be carefully taken into account.</p>

 **Caution**

The motors can have surface temperatures of over +100 °C.

This is the reason that temperature-sensitive components, e.g. cables or electronic components may neither be in contact nor be attached to the motor.

When connecting-up cables, please observe that they

- are not damaged
- are not subject to tensile stress
- cannot be touched by rotating components.

Caution

Motors should be connected-up according to the operating instructions provided. They must not be connected directly to the three-phase supply because this will damage them.

SINAMICS drive units with motors are subject, as part of the routine test, to a voltage test in accordance with EN 50178. While the electrical equipment of industrial machines is being subject to a voltage test in accordance with EN60204-1, Section 19.4, all SINAMICS drive unit connections must be disconnected/withdrawn in order to avoid damaging the SINAMICS drive units.

Caution

The DRIVE-CLiQ interface contains motor and encoder-specific data as well as an electronic rating plate. This is the reason that this Sensor Module may only be operated on the original motor - and may not be mounted onto other motors or replaced by a sensor module from other motors.

The DRIVE-CLiQ interface has direct contact to components that can be damaged/destroyed by electrostatic discharge (ESDS). Neither hands nor tools that could be electrostatically charged may come into contact with the connections.

Note

Under field conditions and in dry service areas, SINAMICS units with motors conform to Low-Voltage Directive 73/23/EEC.

In configurations specified in the associated EC Declaration of Conformity, SINAMICS units with motors conform to the EMC Directive 89/336/EEC.

ESDS instructions

 Caution
<p>An electrostatic-sensitive device (ESDS) is an individual component, integrated circuit, or module that can be damaged by electrostatic fields or discharges.</p> <p>ESDS regulations for handling boards and equipment:</p> <p>When handling components that can be destroyed by electrostatic discharge, it must be ensured that personnel, the workstation and packaging are well grounded!</p> <p>Personnel in ESD zones with conductive floors may only touch electronic components if they are</p> <ul style="list-style-type: none">– grounded through an ESDS bracelet and– wearing ESDS shoes or ESDS shoe grounding strips. <p>Electronic boards may only be touched when absolutely necessary.</p> <p>Electronic boards may not be brought into contact with plastics and articles of clothing manufactured from man-made fibers.</p> <p>Electronic boards may only be placed on conductive surfaces (table with ESDS surface, conductive ESDS foam rubber, ESDS packing bag, ESDS transport containers).</p> <p>Electronic boards may not be brought close to data terminals, monitors or television sets. Minimum clearance to screens > 10 cm).</p> <p>Measurements may only be carried-out on electronic boards and modules if</p> <ul style="list-style-type: none">– the measuring instrument is grounded (e.g. via a protective conductor) or– before making measurements with a potential-free measuring device, the measuring head is briefly discharged <p>(e.g. by touching an unpainted blank piece of metal on the control cabinet).</p>

Information regarding third-party products

Notice
<p>This document contains recommendations relating to third-party products. This involves third-party products whose fundamental suitability is familiar to us. It goes without saying that equivalent products from other manufacturers may be used. Our recommendations are to be seen as helpful information, not as requirements or regulations. We cannot accept any liability for the quality and properties/features of third-party products.</p>

Residual risks

Residual risks of power drive systems

When carrying out a risk assessment of the machine in accordance with the EU Machinery Directive, the machine manufacturer must consider the following residual risks associated with the control and drive components of a power drive system (PDS).

1. Unintentional movements of driven machine components during commissioning, operation, maintenance, and repairs caused by, for example:
 - Hardware defects and/or software errors in the sensors, controllers, actuators, and connection technology
 - Response times of the controller and drive
 - Operating and/or ambient conditions not within the scope of the specification
 - Parameterization, programming, cabling, and installation errors
 - Use of radio devices / cellular phones in the immediate vicinity of the controller
 - External influences / damage
2. Exceptional temperatures as well as emissions of light, noise, particles, or gas caused by, for example:
 - Component malfunctions
 - Software errors
 - Operating and/or ambient conditions not within the scope of the specification
 - External influences / damage
3. Hazardous shock voltages caused by, for example:
 - Component malfunctions
 - Influence of electrostatic charging
 - Induction of voltages in moving motors
 - Operating and/or ambient conditions not within the scope of the specification
 - Condensation / conductive contamination
 - External influences / damage
4. Electrical, magnetic, and electromagnetic fields that can pose a risk to people with a pacemaker and/or implants if they are too close.
5. Emission of pollutants if components or packaging are not disposed of properly.

An assessment of the residual risks of PDS components (see points 1 to 5 above) established that these risks do not exceed the specified limit values (risk priority number to EN 60812 RPZ \leq 125).

For more information about residual risks of the power drive system components, see the relevant chapters in the technical user documentation.

Table of contents

1	Motor description	13
1.1	Features	13
1.2	Technical features.....	15
1.3	Selection and ordering data	16
2	Use	29
2.1	Environment.....	29
2.1.1	Mounting position.....	29
2.1.2	Flange forms	30
2.1.3	Influence of the mounting type and mounted components.....	31
2.1.4	Cooling	32
2.1.5	Degree of protection	33
2.1.6	Paint finish.....	35
2.1.7	Operation under vibrational or shock stress conditions	35
2.1.8	Cantilever force stressing	36
2.1.9	Cantilever force diagrams	36
2.1.10	Calculating the belt pre-tension	38
2.1.11	Axial force stressing.....	39
2.1.12	Brake resistances (armature short-circuit braking).....	39
2.1.13	Drive coupling	44
2.1.14	Storage before use	44
2.2	Electrical connections	45
2.2.1	Power connection	46
2.2.2	DRIVE-CLiQ.....	46
2.2.3	Rotating the connector at the motor	50
3	Mechanical data	51
4	Electrical data	53
4.1	Torque-speed characteristic	53
4.2	Voltage limiting characteristics.....	54
4.3	Field weakening mode	58
4.4	Definitions	60
5	Engineering software	67
5.1	SIZER engineering tool.....	67
5.2	STARTER drive/commissioning software.....	69
5.3	Engineering System Drive ES.....	72
5.4	Procedure when engineering	75
5.4.1	1. Clarification of the type of drive	76
5.4.2	2. Definition of the load event, calculation of max. load torque	77
5.4.3	3. Specification of the motor	82

6	Motor components	83
6.1	Thermal motor protection	83
6.2	Encoder (option).....	85
6.2.1	Encoder overview.....	85
6.2.2	Encoder connection for motors with DRIVE-CLiQ	85
6.2.3	Encoder connection for motors without DRIVE-CLiQ	86
6.2.4	Incremental encoders.....	86
6.2.5	Absolute encoder	87
6.3	Holding brake (option).....	88
6.3.1	Properties	88
6.3.2	Permanent-magnet brake	88
6.3.3	Protective circuitry for the brake	89
6.3.4	Technical data of the holding brake	91
7	Technical data and characteristic curves	93
7.1	Introduction	93
7.2	Technical data and characteristic curves.....	94
8	Dimension drawings	153
A	Appendix	157
A.1	References	157
A.2	Suggestions/corrections.....	161
	Index	163

Motor description

1.1 Features

Overview

The 1FT7 Compact synchronous motors are permanently excited synchronous motors with very compact dimensions. Quick, easy mounting of the motors is possible due to the well proven cross-profile.

The 1FT7 Compact motors fulfill the highest demands on the dynamic response, speed setting range including field weakening, radial eccentricity and positioning accuracy. They are equipped with state-of-the-art encoder technology and optimized for operation on our completely digitally designed drive and control systems.



Figure 1-1 1FT7 Compact synchronous motors

Benefits

1FT7 Compact motors offer:

- High concentricity quality and low torque ripple
- High dynamic response
- High overload capability (up to 4 x M_0 self-cooled)
- Compact design
- High degree of protection (IP65/67)
- Sturdy, vibration-isolated encoder mounting
- Simple encoder replacement on site without alignment
- Quick and easy mounting due to cross-profile
- Rotatable connectors
- New flange form with recessed flange surface, especially suitable for toothed-belt output in the IM V3 type of construction
- Flange form, compatible to the 1FT6 motors can be ordered optionally

Fields of application

- High-performance machine tools
- Machines with stringent requirements in terms of dynamic response and precision, such as packaging machines, textile machines, foil extractor machines, printing machines and production machines.

1.2 Technical features

Table 1-1 Technical features

Motor type	Permanent-magnet synchronous motor
Magnet material	Rare-earth magnetic material
Insulation of the stator winding according to EN 60034-1 (IEC 60034-1)	Temperature class 155 (F) for a winding temperature of $\Delta T = 100$ K at an ambient temperature of +40° C
Installation altitude according to EN 60034-1 (IEC 60034-1)	≤ 1000 m above sea level, otherwise power derating
Type of construction according to EN 60034-7 (IEC 60034-7)	IM B5 (IM V1, IM V3) with flange 0
Degree of protection according to EN60034-5 (IEC 60034-5)	IP65
Cooling	Natural ventilation
Temperature monitoring according to EN 60034-11 (IEC 60034-11)	KTY 84 temperature sensor in stator winding
Paint finish	Pearl dark gray (similar to RAL 9023)
2. Rating plate	Enclosed separately
Drive shaft end according to DIN 748-3 (IEC 60072-1)	Smooth shaft (without keyway)
Radial eccentricity, concentricity and axial eccentricity according to DIN 42955 (IEC 60072-1)	Tolerance N (normal)
Vibration magnitude according to EN 60034-14 (IEC 60034-14)	Grade A is observed up to rated speed
Sound pressure level according to DIN EN ISO 1680	1FT704□ to 1FT706□: 65 dB(A) 1FT708□ to 1FT710□: 70 dB(A) Tolerance + 3 dB(A)
Built-in encoder system for motors without DRIVE-CLiQ interface	<ul style="list-style-type: none"> • Incremental encoder sin/cos 1 Vpp 2048 S/R • Absolute encoder, multiturn, 2048 S/R and traversing range 4096 revolutions with EnDat interface
Built-in encoder system for motors with DRIVE-CLiQ interface	<ul style="list-style-type: none"> • Incremental encoder 22 bit • Absolute encoder 22 bit, multiturn, traversing range 4096 revolutions
Connection	Connectors for signals and power, can be rotated
Options	<ul style="list-style-type: none"> • Type IM B5 (IM V1, IM V3) with flange 1 (compatible with 1FT6) • Drive shaft end with key and keyway (half-key balancing) • Integrated holding brake • Degree of protection IP64, IP67 • Radial eccentricity, concentricity and axial eccentricity: Tolerance R

S/R = Signals/Revolution

1.3 Selection and ordering data

1FT7 Compact core type

Rated speed	Shaft height	Rated power	Static torque	Rated torque	Rated current	Synchronous motors 1FT7 Compact Natural cooling	No. of pole pairs	Rotor moment of inertia (without brake)	Weight (without brake)
n_{rated}	SH	P_{rated} at $\Delta T=100\text{ K}$	M_0 at $\Delta T=100\text{ K}$	M_{rated} at $\Delta T=100\text{ K}$	I_{rated} at $\Delta T=100\text{ K}$	Order No. Core type		J	m
rpm		kW (HP)	Nm (lb _f -in)	Nm (lb _f -in)	A			10^{-4} kgm^2 (lb _f -in-s ²)	kg (lb)
2000	100	5.03 (6.75)	30 (266)	24 (212)	10	1FT7102 - 1AC7 - 1 ■ ■ 1	5	91.4 (0.0809)	26.1 (57.6)
		7.96 (10.7)	50 (443)	38 (336)	15	1FT7105 - 1AC7 - 1 ■ ■ 1	5	178 (0.1575)	44.2 (97.5)
3000	48	1.35 (1.81)	5 (44.3)	4.3 (39.8)	2.6	1FT7044 - 1AF7 - 1 ■ ■ 1	3	5.43 (0.0048)	7.2 (15.9)
		1.7 (2.28)	6 (53.1)	5.4 (47.8)	3.9	1FT7062 - 1AF7 - 1 ■ ■ 1	5	7.36 (0.0065)	7.1 (15.7)
	2.39 (3.20)	9 (79.7)	7.6 (67.3)	5.1	1FT7064 - 1AF7 - 1 ■ ■ 1	5	11.9 (0.0105)	9.7 (21.4)	
	80	3.24 (4.34)	13 (115)	10.5 (92.9)	6.6	1FT7082 - 1AF7 - 1 ■ ■ 1	5	26.5 (0.0235)	14 (30.9)
		4.55 (6.10)	20 (177)	14.5 (128)	8.5	1FT7084 - 1AF7 - 1 ■ ■ 1	5	45.1 (0.0399)	20.8 (45.9)
		5.65 (7.58)	28 (248)	18 (159)	11	1FT7086 - 1AF7 - 1 ■ ■ 1	5	63.6 (0.0563)	31.6 (69.7)
4500	80	4.82 (6.46) ³⁾	20 (177)	11.5 (102) ³⁾	10.1 ³⁾	1FT7084 - 1AH7 - 1 ■ ■ 1	5	45.1 (0.0399)	20.8 (45.9)
6000	63	2.13 (2.86) ¹⁾	6 (53.1)	3.7 (32.7) ¹⁾	5.9 ¹⁾	1FT7062 - 1AK7 - 1 ■ ■ 1	5	7.36 (0.0065)	7.1 (15.7)
		2.59 (3.47) ²⁾	9 (79.7)	5.5 (48.7) ²⁾	6.1 ²⁾	1FT7064 - 1AK7 - 1 ■ ■ 1	5	11.9 (0.0105)	9.7 (21.4)
Type IM B5:			Flange 0			0			
			Flange 1 (compatible with 1FT6)			1			
Encoder systems for motors without DRIVE-CLiQ interface:			Incremental encoder sin/cos 1 V _{pp} 2048 pulses/revolution			N			
			Absolute encoder EnDat 2048 pulses/revolution			M			
Encoder systems for motors with DRIVE-CLiQ interface:			Incremental encoder 22 bit 2048 pulses/revolution			D			
			Absolute encoder 22 bit 2048 pulses/revolution			F			
Shaft extension:			Shaft and flange accuracy:			Holding brake:			
Plain shaft			Tolerance N			without			G
Plain shaft			Tolerance N			with			H
Vibration magnitude:			Degree of protection:						
Grade A			IP65						1

1FT7 Compact core type

Motor type (continued)	Static current I_0 at M_0 $\Delta T=100$ K A	Calculated power P_{calc} ⁶⁾ P_{calc} for M_0 $\Delta T=100$ K kW (HP)	SINAMICS Motor Module		Power cable with complete shield Motor connection (and brake connection) via power connector		
			Rated output current I_{rated} A	Order No. For complete order no., see SINAMICS S120 Drive System ⁵⁾	Power connector Size	Motor cable cross- section ⁴⁾ mm ²	Order No. Pre-assembled cable
1FT7102-1AC7...	12	6.28 (8.42)	18	6SL312 - TE21-8AA.	1.5	4 x 1.5	6FX 002 - 5 S21-....
1FT7105-1AC7...	18	10.47 (14.0)	18	6SL312 - TE21-8AA.	1.5	4 x 2.5	6FX 002 - 5 S31-....
1FT7044-1AF7...	2.8	1.57 (2.11)	3	6SL312 - TE13-0AA.	1	4 x 1.5	6FX 002 - 5 S01-....
1FT7062-1AF7...	3.9	1.88 (2.52)	5	6SL312 - TE15-0AA.	1	4 x 1.5	6FX 002 - 5 S01-....
1FT7064-1AF7...	5.6	2.83 (3.80)	9	6SL312 - TE21-0AA.	1	4 x 1.5	6FX 002 - 5 S01-....
1FT7082-1AF7...	7.6	4.08 (5.47)	9	6SL312 - TE21-0AA.	1	4 x 1.5	6FX 002 - 5 S01-....
1FT7084-1AF7...	11	6.28 (8.42)	18	6SL312 - TE21-8AA.	1	4 x 1.5	6FX 002 - 5 S01-....
1FT7086-1AF7...	15.5	8.8 (11.8)	18	6SL312 - TE21-8AA.	1.5	4 x 2.5	6FX 002 - 5 S31-....
1FT7084-1AH7...	15.6	9.42 (12.6)	18	6SL312 - TE21-8AA.	1.5	4 x 2.5	6FX 002 - 5 S31-....
1FT7062-1AK7...	8.4	3.77 (5.06)	9	6SL312 - TE21-0AA.	1	4 x 1.5	6FX 002 - 5 S01-....
1FT7064-1AK7...	9	5.65 (7.58)	9	6SL312 - TE21-0AA.	1	4 x 1.5	6FX 002 - 5 S01-....

Cooling: Internal air cooling External air cooling	0 1
Motor Module: Single Motor Module Double Motor Module	1 2
Type of power cable: MOTION-CONNECT 800 MOTION-CONNECT 500	8 5
Without brake cores With brake cores	C D
For length code as well as power and signal cables, see MOTION-CONNECT connection system. ⁵⁾

1) These values refer to $n = 5500$ rpm.

2) These values refer to $n = 4500$ rpm.

3) These values refer to $n = 4000$ rpm.

4) The current carrying capacity of the power cables complies with IEC 60204-1 for installation type C under continuous operating conditions at an ambient air temperature of 40 °C (104 °F), designed for I_0 (100 K), PVC/PUR-insulated cable.

5) See catalogs NC 61 · 2005 or D 21.1 · 2006.

6)
$$P_{calc} \text{ [kW]} = \frac{M_0 \text{ [Nm]} \times n_{rated}}{9550}$$

$$P_{calc} \text{ [HP]} = \frac{M_0 \text{ [lb}_f\text{-in]} \times n_{rated}}{63000}$$

1.3 Selection and ordering data

1FT7 Compact standard type

Rated speed	Shaft height	Rated power	Static torque	Rated torque	Rated current	Synchronous motors 1FT7 Compact Natural cooling	No. of pole pairs	Rotor moment of inertia (without brake)	Weight (without brake)
n_{rated} rpm	SH	P_{rated} at $\Delta T=100$ K kW (HP)	M_0 at $\Delta T=100$ K Nm (lb _f -in)	M_{rated} at $\Delta T=100$ K Nm (lb _f -in)	I_{rated} at $\Delta T=100$ K A				
1500	100	4.08 (5.47)	30 (266)	26 (230)	8	1FT7102 - 5AB7 - 1 ■ ■ ■ ■	5	91.4 (0.0809)	26.1 (57.6)
		6.6 (8.85)	50 (443)	42 (372)	13	1FT7105 - 5AB7 - 1 ■ ■ ■ ■	5	178 (0.1575)	44.2 (97.5)
		9.58 (12.9)	70 (620)	61 (540)	16	1FT7108 - 5AB7 - 1 ■ ■ ■ ■	5	248 (0.2195)	59 (130)
Type IM B5:			Flange 0 Flange 1 (compatible with 1FT6)		0 1				
Encoder systems for motors without DRIVE-CLiQ interface:			Incremental encoder sin/cos 1 V _{pp} 2048 pulses/revolution Absolute encoder EnDat 2048 pulses/revolution			N M			
Encoder systems for motors with DRIVE-CLiQ interface:			Incremental encoder 22 bit 2048 pulses/revolution Absolute encoder 22 bit 2048 pulses/revolution			D F			
Shaft extension:			Shaft and flange accuracy:		Holding brake:				
Fitted key and keyway			Tolerance N		without				A
Fitted key and keyway			Tolerance N		with				B
Fitted key and keyway			Tolerance R		without				D
Fitted key and keyway			Tolerance R		with				E
Plain shaft			Tolerance N		without				G
Plain shaft			Tolerance N		with				H
Plain shaft			Tolerance R		without				K
Plain shaft			Tolerance R		with				L
Vibration magnitude:			Degree of protection:						
Grade A			IP64						0
Grade A			IP65						1
Grade A			IP67						2

1FT7 Compact standard type

Motor type (continued)	Static current I_0 at M_0 $\Delta T=100$ K A	Calculated power P_{calc} ³⁾ P_{calc} for M_0 $\Delta T=100$ K kW (HP)	SINAMICS Motor Module		Power cable with complete shield Motor connection (and brake connection) via power connector		
			Rated output current I_{rated} A	Order No. For complete order no., see SINAMICS S120 Drive System ²⁾	Power connector Size	Motor cable cross- section ¹⁾ mm ²	Order No. Pre-assembled cable
1FT7102-5AB7...	9	4.71 (6.32)	9	6SL312 - TE21-0AA.	1.5	4 x 1.5	6FX 002 -5 S21-....
1FT7105-5AB7...	15	7.85 (10.5)	18	6SL312 - TE21-8AA.	1.5	4 x 1.5	6FX 002 -5 S21-....
1FT7108-5AB7...	18	10.99 (14.7)	18	6SL312 - TE21-8AA.	1.5	4 x 2.5	6FX 002 -5 S31-....
Cooling:							
Internal air cooling				0			
External air cooling				1			
Motor Module:							
Single Motor Module				1			
Double Motor Module				2			
Type of power cable:							
MOTION-CONNECT 800						8	
MOTION-CONNECT 500						5	
Without brake cores							C
With brake cores							D
For length code as well as power and signal cables, see MOTION-CONNECT connection system. ²⁾						

¹⁾ The current carrying capacity of the power cables complies with IEC 60204-1 for installation type C under continuous operating conditions at an ambient air temperature of 40 °C (104 °F), designed for I_0 (100 K), PVC/PUR-insulated cable.

²⁾ See catalogs NC 61 · 2005 or D 21.1 · 2006.

³⁾
$$P_{calc} [kW] = \frac{M_0 [Nm] \times n_{rated}}{9550}$$

$$P_{calc} [HP] = \frac{M_0 [lb_f \cdot in] \times n_{rated}}{63000}$$

Motor description

1.3 Selection and ordering data

1FT7 Compact standard type

Rated speed	Shaft height	Rated power	Static torque	Rated torque	Rated current	Synchronous motors 1FT7 Compact Natural cooling	No. of pole pairs	Rotor moment of inertia (without brake)	Weight (without brake)			
n_{rated}	SH	P_{rated} at $\Delta T=100\text{ K}$	M_0 at $\Delta T=100\text{ K}$	M_{rated} at $\Delta T=100\text{ K}$	I_{rated} at $\Delta T=100\text{ K}$					Order No.	J	m
rpm		kW (HP)	Nm (lb _f -in)	Nm (lb _f -in)	A					Standard type	10^{-4} kgm^2 (lb _f -in-s ²)	kg (lb)
2000	80	2.39 (3.20)	13 (115)	11.4 (101)	4.7	1FT7082 - 5AC7 - 1 ■ ■ ■ ■	5	26.5 (0.0235)	14 (30.9)			
		3.54 (4.75)	20 (177)	16.9 (150)	7.8	1FT7084 - 5AC7 - 1 ■ ■ ■ ■	5	45.1 (0.0399)	20.8 (45.9)			
		4.71 (6.32)	28 (248)	22.5 (199)	9.2	1FT7086 - 5AC7 - 1 ■ ■ ■ ■	5	63.6 (0.0563)	31.8 (70.1)			
	100	5.03 (6.75)	30 (266)	24 (212)	10	1FT7102 - 5AC7 - 1 ■ ■ ■ ■	5	91.4 (0.0809)	26.1 (57.6)			
		7.96 (10.7)	50 (443)	38 (336)	15	1FT7105 - 5AC7 - 1 ■ ■ ■ ■	5	178 (0.1575)	44.1 (97.2)			
		10.5 (14.1)	70 (620)	50 (443)	18	1FT7108 - 5AC7 - 1 ■ ■ ■ ■	5	248 (0.2195)	59 (130)			
Type IM B5:			Flange 0		0							
			Flange 1 (compatible with 1FT6)		1							
Encoder systems for motors without DRIVE-CLiQ interface:			Incremental encoder sin/cos 1 V _{pp} 2048 pulses/revolution			N						
			Absolute encoder EnDat 2048 pulses/revolution			M						
Encoder systems for motors with DRIVE-CLiQ interface:			Incremental encoder 22 bit 2048 pulses/revolution			D						
			Absolute encoder 22 bit 2048 pulses/revolution			F						
Shaft extension:		Shaft an flange accuracy:		Holding brake:								
Fitted key and keyway		Tolerance N		without		A B D E G H K L						
Fitted key and keyway		Tolerance N		with								
Fitted key and keyway		Tolerance R		without								
Fitted key and keyway		Tolerance R		with								
Plain shaft		Tolerance N		without								
Plain shaft		Tolerance N		with								
Plain shaft		Tolerance R		without								
Plain shaft		Tolerance R		with								
Vibration magnitude:		Degree of protection:										
Grade A		IP64		0 1 2								
Grade A		IP65										
Grade A		IP67										

1FT7 Compact standard type

Motor type (continued)	Static current I_0 at M_0 $\Delta T=100$ K A	Calculated power $P_{calc}^{3)}$ P_{calc} for M_0 $\Delta T=100$ K kW (HP)	SINAMICS Motor Module		Power cable with complete shield Motor connection (and brake connection) via power connector		
			Rated output current I_{rated} A	Order No. For complete order no., see SINAMICS S120 Drive System ²⁾	Power connector Size	Motor cable cross- section ¹⁾ mm ²	Order No. Pre-assembled cable
1FT7082-5AC7...	4.9	2.72 (3.65)	5	6SL312 - TE15-0AA.	1	4 x 1.5	6FX 002 - 5S01-....
1FT7084-5AC7...	8.5	4.19 (5.62)	9	6SL312 - TE21-0AA.	1	4 x 1.5	6FX 002 - 5S01-....
1FT7086-5AC7...	10.6	5.86 (7.86)	18	6SL312 - TE21-8AA.	1	4 x 1.5	6FX 002 - 5S01-....
1FT7102-5AC7...	12	6.28 (8.42)	18	6SL312 - TE21-8AA.	1.5	4 x 1.5	6FX 002 - 5S21-....
1FT7105-5AC7...	18	10.47 (14.0)	18	6SL312 - TE21-8AA.	1.5	4 x 2.5	6FX 002 - 5S31-....
1FT7108-5AC7...	25	14.66 (19.7)	30	6SL312 - TE23-1AA.	1.5	4 x 4	6FX 002 - 5S41-....
Cooling: Internal air cooling External air cooling							
Motor Module: Single Motor Module Double Motor Module							
Type of power cable: MOTION-CONNECT 800 MOTION-CONNECT 500							
Without brake cores With brake cores							
For length code as well as power and signal cables, see MOTION-CONNECT connection system. ²⁾							

¹⁾ The current carrying capacity of the power cables complies with IEC 60204-1 for installation type C under continuous operating conditions at an ambient air temperature of 40 °C (104 °F), designed for I_0 (100 K), PVC/PUR-insulated cable.

²⁾ See catalogs NC 61 · 2005 or D 21.1 · 2006.

³⁾
$$P_{calc} [kW] = \frac{M_0 [Nm] \times n_{rated}}{9550}$$

$$P_{calc} [HP] = \frac{M_0 [lb_f \cdot in] \times n_{rated}}{63000}$$

Motor description

1.3 Selection and ordering data

1FT7 Compact standard type

Rated speed	Shaft height	Rated power	Static torque	Rated torque	Rated current	Synchronous motors 1FT7 Compact Natural cooling	No. of pole pairs	Rotor moment of inertia (without brake)	Weight (without brake)
n_{rated}	SH	P_{rated} at $\Delta T=100\text{ K}$	M_0 at $\Delta T=100\text{ K}$	M_{rated} at $\Delta T=100\text{ K}$	I_{rated} at $\Delta T=100\text{ K}$	Order No. Standard type		J	m
rpm		kW (HP)	Nm (lb _f -in)	Nm (lb _f -in)	A			10 ⁻⁴ kgm ² (lb _f -in-s ²)	kg (lb)
3000	48	0.85 (1.14)	3 (26.6)	2.7 (23.9)	2.1	1FT7042 - 5AF 7 - 1 ■ ■ ■ ■	3	2.81 (0.0025)	4.6 (10.1)
		1.35 (1.81)	5 (44.3)	4.3 (38.1)	2.6	1FT7044 - 5AF 7 - 1 ■ ■ ■ ■	3	5.43 (0.0048)	7.2 (15.9)
		1.76 (2.36)	7 (62.0)	5.6 (49.6)	3.5	1FT7046 - 5AF 7 - 1 ■ ■ ■ ■	3	7.52 (0.0067)	9.3 (20.5)
	63	1.7 (2.28)	6 (53.1)	5.4 (47.8)	3.9	1FT7062 - 5AF 7 - 1 ■ ■ ■ ■	5	7.36 (0.0065)	7.1 (15.7)
		2.39 (3.20)	9 (79.7)	7.6 (67.3)	5.1	1FT7064 - 5AF 7 - 1 ■ ■ ■ ■	5	11.9 (0.0105)	9.7 (21.4)
		2.92 (3.92)	12 (106)	9.3 (82.3)	7.2	1FT7066 - 5AF 7 - 1 ■ ■ ■ ■	5	16.4 (0.0145)	12.3 (27.1)
		3.42 (4.59)	15 (133)	10.9 (96.5)	6.7	1FT7068 - 5AF 7 - 1 ■ ■ ■ ■	5	23.2 (0.0205)	16.3 (35.9)
	80	3.24 (4.34)	13 (115)	10.5 (92.9)	6.6	1FT7082 - 5AF 7 - 1 ■ ■ ■ ■	5	26.5 (0.0235)	14 (30.9)
		4.55 (6.10)	20 (177)	14.5 (128)	8.5	1FT7084 - 5AF 7 - 1 ■ ■ ■ ■	5	45.1 (0.0399)	20.8 (45.9)
		5.62 (7.54)	28 (248)	18 (159)	11	1FT7086 - 5AF 7 - 1 ■ ■ ■ ■	5	63.6 (0.0563)	31.8 (70.1)
	100	6.28 (8.42)	30 (266)	20 (177)	12	1FT7102 - 5AF 7 - 1 ■ ■ ■ ■	5	91.4 (0.0809)	26.1 (57.6)
		8.8 (11.8)	50 (443)	28 (248)	15	1FT7105 - 5AF 7 - 1 ■ ■ ■ ■	5	178 (0.1575)	44.2 (97.5)
Type IM B5:			Flange 0 Flange 1 (compatible with 1FT6)			0 1			
Encoder systems for motors without DRIVE-CLiQ interface:			Incremental encoder sin/cos 1 V _{pp} 2048 pulses/revolution Absolute encoder EnDat 2048 pulses/revolution			N M			
Encoder systems for motors with DRIVE-CLiQ interface:			Incremental encoder 22 bit 2048 pulses/revolution Absolute encoder 22 bit 2048 pulses/revolution			D F			
Shaft extension:		Shaft and flange accuracy:		Holding brake:			A B D E G H K L		
Fitted key and keyway		Tolerance N		without					
Fitted key and keyway		Tolerance N		with					
Fitted key and keyway		Tolerance R		without					
Fitted key and keyway		Tolerance R		with					
Plain shaft		Tolerance N		without					
Plain shaft		Tolerance N		with					
Plain shaft		Tolerance R		without					
Plain shaft		Tolerance R		with					
Vibration magnitude:			Degree of protection:			0 1 2			
Grade A			IP64						
Grade A			IP65						
Grade A			IP67						

1FT7 Compact standard type

Motor type (continued)	Static current I_0 at M_0 $\Delta T=100$ K A	Calculated power P_{calc} ³⁾ P_{calc} for M_0 $\Delta T=100$ K kW (HP)	SINAMICS Motor Module		Power cable with complete shield Motor connection (and brake connection) via power connector		
			Rated output current I_{rated} A	Order No. For complete order no., see SINAMICS S120 Drive System ²⁾	Power connector Size	Motor cable cross-section ¹⁾ mm ²	Order No. Pre-assembled cable
1FT7042-5AF7...	2.1	0.94 (1.26)	3	6SL312 - TE13-0AA.	1	4 x 1.5	6FX 002 - 5 S01 -....
1FT7044-5AF7...	2.8	1.57 (2.11)	3	6SL312 - TE13-0AA.	1	4 x 1.5	6FX 002 - 5 S01 -....
1FT7046-5AF7...	4	2.2 (2.95)	5	6SL312 - TE15-0AA.	1	4 x 1.5	6FX 002 - 5 S01 -....
1FT7062-5AF7...	3.9	1.88 (2.52)	5	6SL312 - TE15-0AA.	1	4 x 1.5	6FX 002 - 5 S01 -....
1FT7064-5AF7...	5.6	2.83 (3.80)	9	6SL312 - TE21-0AA.	1	4 x 1.5	6FX 002 - 5 S01 -....
1FT7066-5AF7...	8.4	3.77 (5.06)	9	6SL312 - TE21-0AA.	1	4 x 1.5	6FX 002 - 5 S01 -....
1FT7068-5AF7...	8.3	4.71 (6.32)	9	6SL312 - TE21-0AA.	1	4 x 1.5	6FX 002 - 5 S01 -....
1FT7082-5AF7...	7.6	4.08 (5.47)	9	6SL312 - TE21-0AA.	1	4 x 1.5	6FX 002 - 5 S01 -....
1FT7084-5AF7...	11	6.28 (8.42)	18	6SL312 - TE21-8AA.	1	4 x 1.5	6FX 002 - 5 S01 -....
1FT7086-5AF7...	15.5	8.8 (11.8)	18	6SL312 - TE21-8AA.	1.5	4 x 2.5	6FX 002 - 5 S31 -....
1FT7102-5AF7...	18	9.42 (12.6)	18	6SL312 - TE21-8AA.	1.5	4 x 2.5	6FX 002 - 5 S31 -....
1FT7105-5AF7...	26	15.71 (21.1)	30	6SL312 - TE23-1AA.	1.5	4 x 4	6FX 002 - 5 S41 -....
Cooling:							
Internal air cooling				0			
External air cooling				1			
Motor Module:							
Single Motor Module				1			
Double Motor Module				2			
Type of power cable:							
MOTION-CONNECT 800						8	
MOTION-CONNECT 500						5	
Without brake cores							C
With brake cores							D
For length code as well as power and signal cables, see MOTION-CONNECT connection system. ²⁾						

¹⁾ The current carrying capacity of the power cables complies with IEC 60204-1 for installation type C under continuous operating conditions at an ambient air temperature of 40 °C (104 °F), designed for I_0 (100 K), PVC/PUR-insulated cable.

²⁾ See catalogs NC 61 · 2005 or D21.1 · 2006.

³⁾
$$P_{calc} [kW] = \frac{M_0 [Nm] \times n_{rated}}{9550}$$

$$P_{calc} [HP] = \frac{M_0 [lb_f-in] \times n_{rated}}{63000}$$

Motor description

1.3 Selection and ordering data

1FT7 Compact standard type

Rated speed	Shaft height	Rated power	Static torque	Rated torque	Rated current	Synchronous motors 1FT7 Compact Natural cooling Order No. Standard type	No. of pole pairs	Rotor moment of inertia (without brake) J 10^{-4} kgm^2 ($\text{lb}_f\text{-in-s}^2$)	Weight (without brake) m kg (lb)
n_{rated}	SH	P_{rated} at $\Delta T=100 \text{ K}$	M_0 at $\Delta T=100 \text{ K}$	M_{rated} at $\Delta T=100 \text{ K}$	I_{rated} at $\Delta T=100 \text{ K}$				
rpm		kW (HP)	Nm ($\text{lb}_f\text{-in}$)	Nm ($\text{lb}_f\text{-in}$)	A				
4500	48	1.32 (1.77) ¹⁾	7 (62.0)	3.6 (31.9) ¹⁾	4.7 ¹⁾	1FT7046 - 5AH7 - 1 ■ ■ ■ ■	3	7.52 (0.0067)	9.3 (20.5)
	63	2.55 (3.42) ²⁾	12 (106)	6.1 (54.0) ²⁾	7.5 ²⁾	1FT7066 - 5AH7 - 1 ■ ■ ■ ■	5	16.4 (0.0145)	12.3 (27.1)
	80	3.77 (5.06) 4.82 (42.7) ²⁾	13 (115) 20 (177)	8 (70.8) 11.5 (102) ²⁾	8.4 10.1 ²⁾	1FT7082 - 5AH7 - 1 ■ ■ ■ ■ 1FT7084 - 5AH7 - 1 ■ ■ ■ ■	5 5	26.5 (0.0235) 45.1 (0.0399)	14 (30.9) 20.8 (45.9)
Type IM B5:			Flange 0 Flange 1 (compatible with 1FT6)		0 1				
Encoder systems for motors without DRIVE-CLiQ interface:			Incremental encoder sin/cos 1 V_{pp} 2048 pulses/revolution Absolute encoder EnDat 2048 pulses/revolution						N M
Encoder systems for motors with DRIVE-CLiQ interface:			Incremental encoder 22 bit 2048 pulses/revolution Absolute encoder 22 bit 2048 pulses/revolution						D F
Shaft extension:		Shaft and flange accuracy:		Holding brake:					A B D E G H K L
Fitted key and keyway		Tolerance N		without					
Fitted key and keyway		Tolerance N		with					
Fitted key and keyway		Tolerance R		without					
Fitted key and keyway		Tolerance R		with					
Plain shaft		Tolerance N		without					
Plain shaft		Tolerance N		with					
Plain shaft		Tolerance R		without					
Plain shaft		Tolerance R		with					
Vibration magnitude:		Degree of protection:							0 1 2
Grade A		IP64							
Grade A		IP65							
Grade A		IP67							

1FT7 Compact standard type

Motor type (continued)	Static current I_0 at M_0 $\Delta T=100$ K A	Calculated power P_{calc} ⁵⁾ P_{calc} for M_0 $\Delta T=100$ K kW (HP)	SINAMICS Motor Module		Power cable with complete shield Motor connection (and brake connection) via power connector		
			Rated output current I_{rated} A	Order No. For complete order no., see SINAMICS S120 Drive System ⁴⁾	Power connector Size	Motor cable cross- section ³⁾ mm ²	Order No. Pre-assembled cable
1FT7046-5AH7...	8.1	3.3 (4.43)	9	6SL312 - TE21-0AA.	1	4 x 1.5	6FX 002 - 5 S01 -....
1FT7066-5AH7...	13.6	5.65 (7.58)	18	6SL312 - TE21-8AA.	1	4 x 1.5	6FX 002 - 5 S01 -....
1FT7082-5AH7...	12.3	6.13 (8.22)	18	6SL312 - TE21-8AA.	1	4 x 1.5	6FX 002 - 5 S01 -....
1FT7084-5AH7...	15.6	9.42 (12.6)	18	6SL312 - TE21-8AA.	1.5	4 x 2.5	6FX 002 - 5 S31 -....
Cooling: Internal air cooling					0		
External air cooling					1		
Motor Module: Single Motor Module					1		
Double Motor Module					2		
Type of power cable: MOTION-CONNECT 800						8	
MOTION-CONNECT 500						5	
Without brake cores							C
With brake cores							D
For length code as well as power and signal cables, see MOTION-CONNECT connection system. ⁴⁾						

1) These values refer to $n = 3500$ rpm.

2) These values refer to $n = 4000$ rpm.

3) The current carrying capacity of the power cables complies with IEC 60204-1 for installation type C under continuous operating conditions at an ambient air temperature of 40 °C (104 °F), designed for I_0 (100 K), PVC/PUR-insulated cable.

4) See catalogs NC 61 · 2005 or D 21.1 · 2006.

5)
$$P_{calc} \text{ [kW]} = \frac{M_0 \text{ [Nm]} \times n_{rated}}{9550}$$

$$P_{calc} \text{ [HP]} = \frac{M_0 \text{ [lb}_f\text{-in]} \times n_{rated}}{63000}$$

Motor description

1.3 Selection and ordering data

1FT7 Compact standard type

Rated speed	Shaft height	Rated power	Static torque	Rated torque	Rated current	Synchronous motors 1FT7 Compact Natural cooling	No. of pole pairs	Rotor moment of inertia (without brake)	Weight (without brake)			
n_{rated}	SH	P_{rated} at $\Delta T=100\text{ K}$	M_0 at $\Delta T=100\text{ K}$	M_{rated} at $\Delta T=100\text{ K}$	I_{rated} at $\Delta T=100\text{ K}$					Order No.	J	m
rpm		kW (HP)	Nm (lb _f -in)	Nm (lb _f -in)	A					Standard type	10^{-4} kgm^2 (lb _f -in-s ²)	kg (lb)
6000	48	1.26 (1.69)	3 (26.6)	2 (17.7)	3	1FT7042 - 5AK7 - 1 ■ ■ ■ ■	3	2.81 (0.0025)	4.6 (10.1)			
		1.41(1.89) ¹⁾	5 (44.3)	3 (26.6) ¹⁾	3.6 ¹⁾	1FT7044 - 5AK7 - 1 ■ ■ ■ ■	3	5.43 (0.0048)	7.2 (15.9)			
	60	2.13 (2.86) ²⁾	6 (53.1)	3.7 (32.7) ²⁾	5.9 ²⁾	1FT7062 - 5AK7 - 1 ■ ■ ■ ■	5	7.36 (0.0065)	7.1 (15.7)			
		2.59 (3.47) ¹⁾	9 (79.7)	5.5 (48.7) ¹⁾	6.1 ¹⁾	1FT7064 - 5AK7 - 1 ■ ■ ■ ■	5	11.9 (0.0105)	9.7 (21.4)			
Type IM B5:			Flange 0		0							
			Flange 1 (compatible with 1FT6)		1							
Encoder systems for motors without DRIVE-CLiQ interface:			Incremental encoder sin/cos 1 V _{pp} 2048 pulses/revolution			N						
			Absolute encoder EnDat 2048 pulses/revolution			M						
Encoder systems for motors with DRIVE-CLiQ interface:			Incremental encoder 22 bit 2048 pulses/revolution			D						
			Absolute encoder 22 bit 2048 pulses/revolution			F						
Shaft extension:		Shaft and flange accuracy:		Holding brake:								
Fitted key and keyway		Tolerance N		without					A			
Fitted key and keyway		Tolerance N		with					B			
Fitted key and keyway		Tolerance R		without					D			
Fitted key and keyway		Tolerance R		with					E			
Plain shaft		Tolerance N		without					G			
Plain shaft		Tolerance N		with					H			
Plain shaft		Tolerance R		without					K			
Plain shaft		Tolerance R		with					L			
Vibration magnitude:			Degree of protection:									
Grade A			IP64						0			
Grade A			IP65						1			
Grade A			IP67						2			

1FT7 Compact standard type

Motor type (continued)	Static current I_0 at M_0 $\Delta T=100$ K A	Calculated power P_{calc} ⁵⁾ P_{calc} for M_0 $\Delta T=100$ K kW (HP)	SINAMICS Motor Module		Power cable with complete shield Motor connection (and brake connection) via power connector		
			Rated output current I_{rated} A	Order No. For complete order no., see SINAMICS S120 Drive System ⁴⁾	Power connector Size	Motor cable cross- section ³⁾ mm ²	Order No. Pre-assembled cable
1FT7042-5AK7...	3.9	1.89 (2.53)	5	6SL312 - TE15-0AA.	1	4 x 1.5	6FX 002 - 5S01-....
1FT7044-5AK7...	5.7	3.15 (4.22)	9	6SL312 - TE21-0AA.	1	4 x 1.5	6FX 002 - 5S01-....
1FT7062-5AK7...	8.4	3.78 (5.07)	9	6SL312 - TE21-0AA.	1	4 x 1.5	6FX 002 - 5S01-....
1FT7064-5AK7...	9	5.67 (7.60)	9	6SL312 - TE21-0AA.	1	4 x 1.5	6FX 002 - 5S01-....
Cooling:							
Internal air cooling							0
External air cooling							1
Motor Module:							
Single Motor Module							1
Double Motor Module							2
Type of power cable:							
MOTION-CONNECT 800							8
MOTION-CONNECT 500							5
Without brake cores							C
With brake cores							D
For length code as well as power and signal cables, see MOTION-CONNECT connection system. ⁴⁾						

1) These values refer to $n = 4500$ rpm.

2) These values refer to $n = 5500$ rpm.

3) The current carrying capacity of the power cables complies with IEC 60204-1 for installation type C under continuous operating conditions at an ambient air temperature of 40 °C (104 °F), designed for I_0 (100 K), PVC/PUR-insulated cable.

4) See catalogs NC 61 · 2005 or D 21.1 · 2006.

5)
$$P_{calc} [kW] = \frac{M_0 [Nm] \times n_{rated}}{9550}$$

$$P_{calc} [HP] = \frac{M_0 [lb_f-in] \times n_{rated}}{63000}$$

Use

2.1 Environment

2.1.1 Mounting position

Table 2-1 Mounting positions

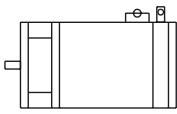
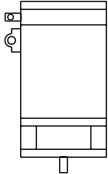
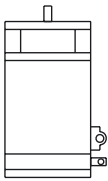
Designation	Representation	Description
IM B5		Standard
IM V1		<p>Note:</p> <p>When configuring the IM V1 and IM V3 type of construction, attention must be paid to the permissible axial forces (weight force of the drive elements) and especially to the necessary degree of protection.</p> <p>For IM V3 preferably flange form 0 1FT7□□□-□□□□0-□□□□</p> <p>Attention must be paid to suitable coverage of the motor shaft (splash water).</p>
IM V3		

2.1.2 Flange forms

Table 2-2 Flange forms

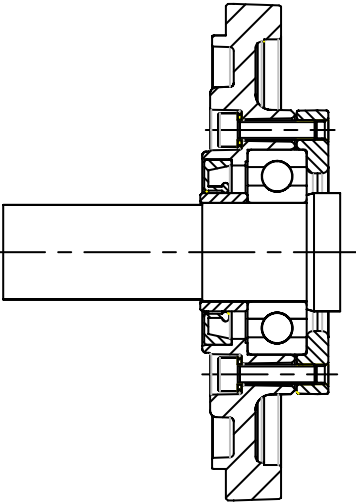
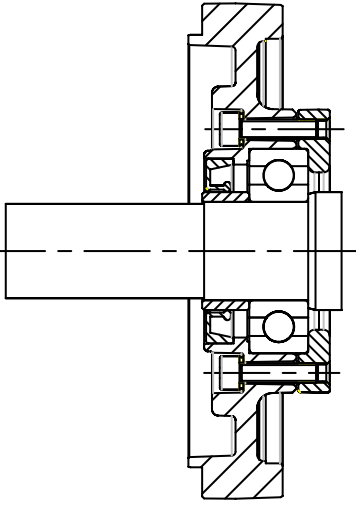
Designation	Representation	Description
IM B5		Flange 0, recessed 1FT7□□□-□□□□0-□□□□
IM B5		Flange 1, compatible with 1FT6 motors 1FT7□□□-□□□□1-□□□□

2.1.3 Influence of the mounting type and mounted components

Some of the motor power loss is dissipated through the flange when the motor is connected to the mounting flange.

Non-thermally insulated mounting

The following mounting conditions apply for the specified motor data:

Table 2-3 Non-thermally insulated mounting conditions

Shaft height	Steel plate, width x height x thickness [mm]	Mounting surface[m ²]
48	120 x 100 x 40	0,012
63 to 100	450 x 370 x 30	0,17

For larger mounting surfaces, the heat dissipation conditions improve.

Thermally insulated mounting without additionally mounted components

For non-ventilated and force-ventilated motors, the static motor torque must be reduced by between 5% and 15%. We recommend configuring the motor using the $M_{0(60K)}$ values.

Thermally insulated mounting with additionally mounted components

- Holding brake (integrated in the motor). No additional torque reduction required
- Gearbox; the torque has to be reduced (refer to Figure "S1 characteristics")

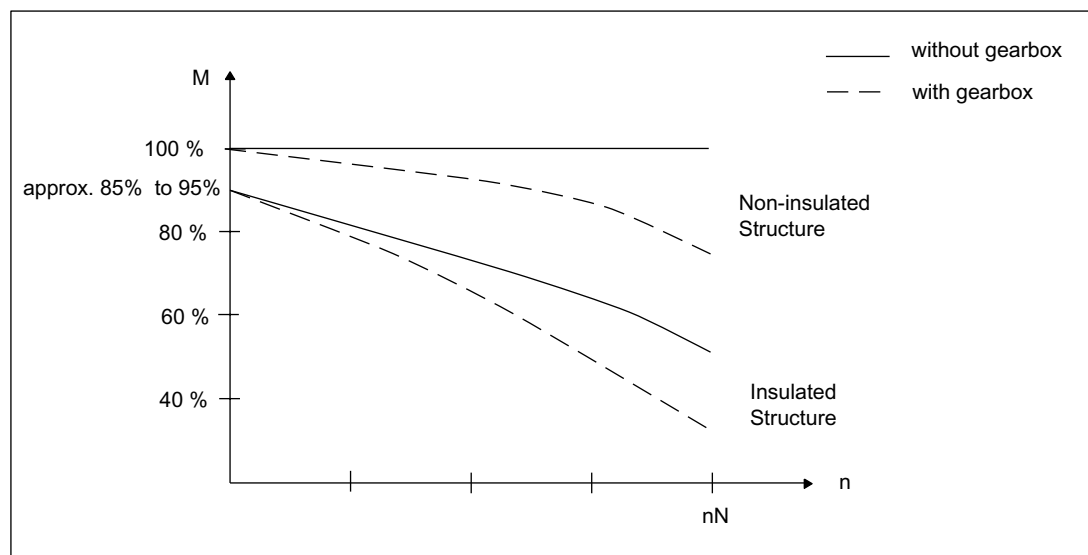

Figure 2-1 S1 characteristics

2.1.4 Cooling

The motors of the 1FT7 Compact series are self-cooled.

Operating temperature range: -15° C to +40° C (without any restrictions).

The power loss is dissipated through radiation and natural convection which means that adequate heat dissipation must be ensured by suitably mounting the motor.

All of the catalog data refer to an ambient temperature of 40° C, mounted so that the motors are not thermally insulated and an installation altitude up to 1000 m above sea level.

If other conditions prevail (ambient temperature > 40° C or installation altitude > 1000 m above sea level), the permissible torque/power must be defined using the factors from the following table (torque/power reduction according to EN 60034-6).

Ambient temperatures and installation altitudes are rounded-off to 5° C or 500 m respectively.

Table 2-4 Power de-rating as a function of the installation altitude and the ambient temperature

Site altitude above sea level [m]	Ambient temperature in ° C					
	< 30	30–40	45	50	55	60
1000	1,07	1,00	0,96	0,92	0,87	0,82
1500	1,04	0,97	0,93	0,89	0,84	0,79
2000	1,00	0,94	0,90	0,86	0,82	0,77
2500	0,96	0,90	0,86	0,83	0,78	0,74
3000	0,92	0,86	0,82	0,79	0,75	0,70
3500	0,88	0,82	0,79	0,75	0,71	0,67
4000	0,82	0,77	0,74	0,71	0,67	0,63

 **Caution**

The surfaces of synchronous motors can have temperatures > 100° C. When required, protective measures must be provided to prevent coming into contact with the motors.

2.1.5 Degree of protection

The degree of protection designation in accordance with EN 60034-5 (IEC 60034-5) is described using the letters "IP" and two digits (e.g. IP64). The first digit specifies the protection against penetration of foreign matter, the second digit specifies the protection against water.

Since most cooling lubricants used in machine tools and transfer machines are oily, creep-capable, and/or corrosive, protection against water alone is insufficient. The servo motors must be protected by suitable covers.

Attention must be paid to providing suitable sealing of the motor shaft for the selected degree of protection for the motor.

Notice
For a mounting position with vertical shaft end (IM V3), liquid collects in the flange is only permitted with IP67 and recessed DE flange (type 0).

Sealing of the motor shaft

Table 2-5 Motor shaft sealing

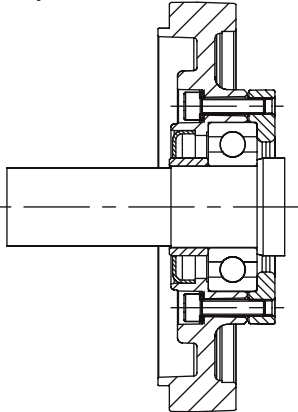
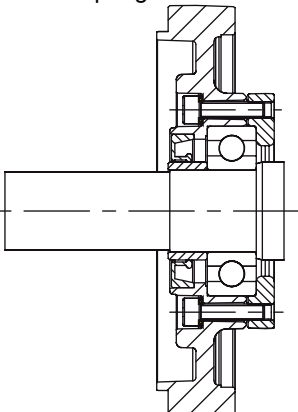
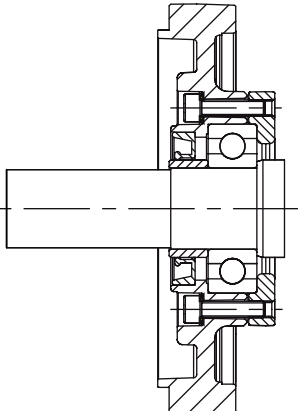
Degree of protection	Shaft sealing using	Area of application
IP64	Labyrinth seal 	It is not permissible that there is any moisture in the area around the shaft and the flange. Note: For IP 64 degree of protection it is not permissible that liquid collects in the flange. Shaft outlet is not dust-tight
IP65	Radial shaft sealing ring without annular spring 	Shaft outlet seal to protect against spray water and cooling-lubricating medium. It is permissible that the radial shaft sealing ring runs dry. Lifetime approx. 25000 h (nominal value). For IP65 degree of protection it is not permissible that liquid collects in the flange.
IP67	Radial shaft sealing ring 	For gearbox mounting (for gearboxes that are not sealed) to seal against oil. The sealing lip must be adequately cooled and lubricated by the gearbox oil in order to guarantee reliable function. Lifetime approx. 10000 h (nominal value). If a radial shaft sealing ring runs dry, then this has a negative impact on the functionality and the lifetime.

Routing cables in a wet/moist environment

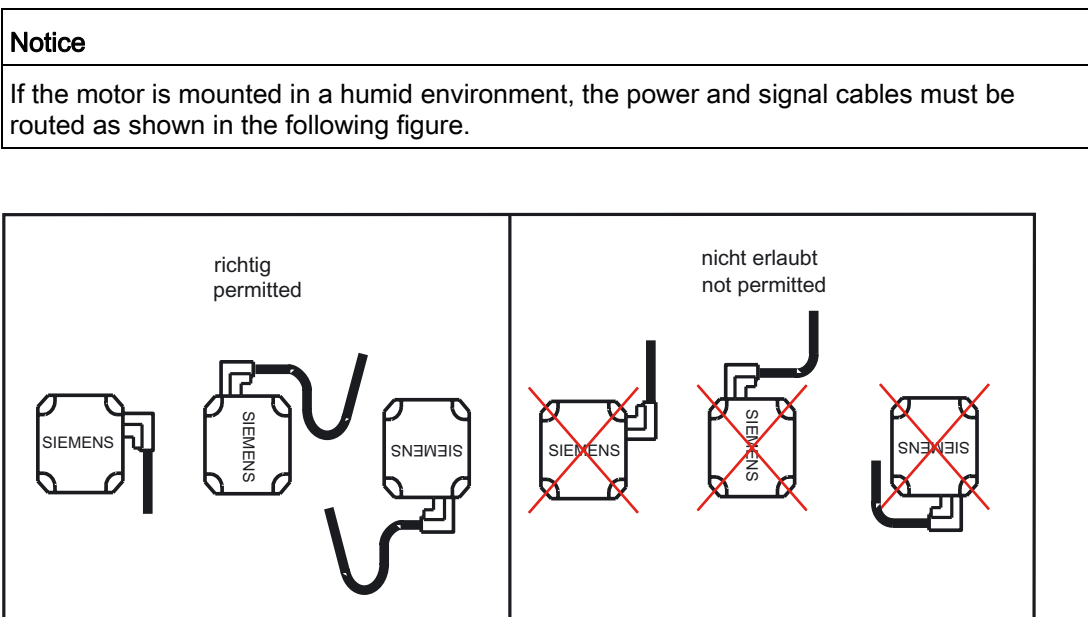

Figure 2-2 Routing cables in a wet/moist environment

2.1.6 Paint finish

The motors of the 1FT7 Compact series are painted as standard. Paint finish: Pearl dark gray (similar to RAL 9023)

2.1.7 Operation under vibrational or shock stress conditions

In order to ensure problem-free operation and a long service life, the vibration values defined in DIN ISO 10816 should not be exceeded.

Table 2-6 Vibration values

Vibrational velocity V_{rms} [mm/s] acc. to DIN ISO 10816	Frequency f [Hz]	Acceleration a [m/s ²]
4,5	10	0,4
4,5	250	10

Deviating from the specified standard, motors 1FT704□ to 1FT710□ may be operated with higher loads, with the stipulation that the service life will be reduced. In this case, only operation outside the mounted natural frequency is permissible.

Peak acceleration	Axial 20 m/s ²	Radial 50 m/s ²
Shock duration	3 ms	3 ms

2.1.8 Cantilever force stressing

Point of application of cantilever forces F_Q at the shaft end

- for average operating speeds
- for a nominal bearing lifetime of 20,000 h

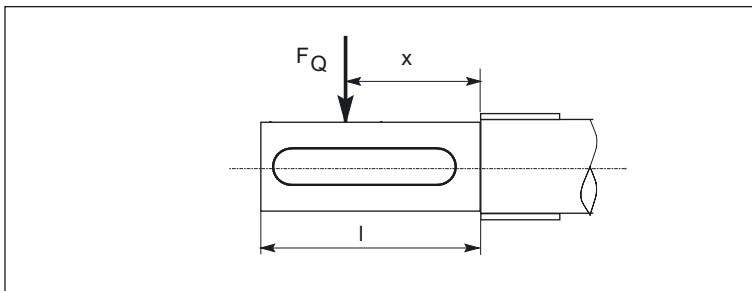

Figure 2-3 Force application point at the drive shaft end

Dimension x : Distance between the point of application of force F_Q and the shaft shoulder in mm.

Dimension l : Length of the shaft end in mm.

2.1.9 Cantilever force diagrams

Cantilever force, 1FT7 Compact, AH 48

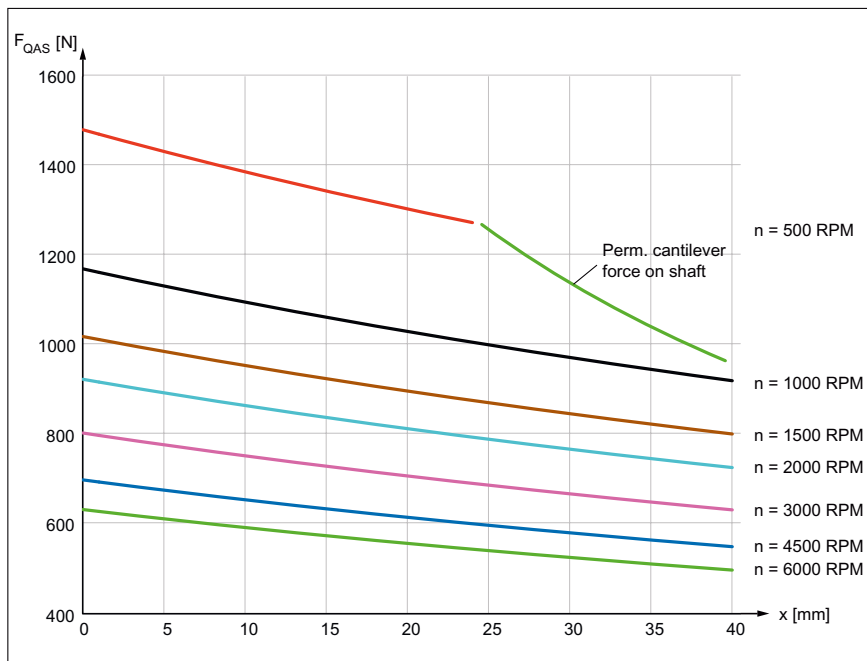

Figure 2-4 Cantilever force F_Q at a distance x from the shaft shoulder for a statistical bearing lifetime of 20000 h

Cantilever force, 1FT7 Compact, AH 63

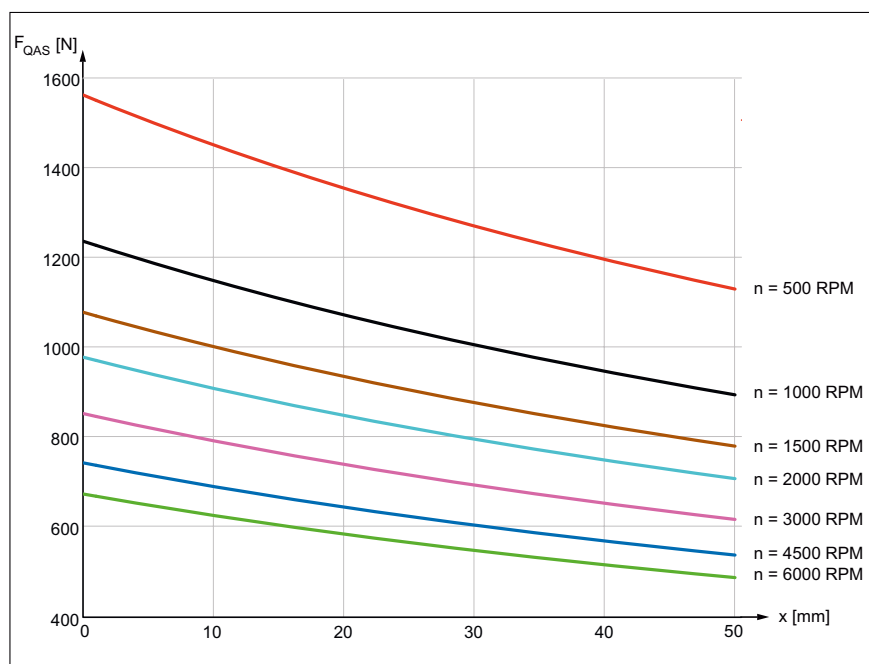

Figure 2-5 Cantilever force F_Q at a distance x from the shaft shoulder for a statistical bearing lifetime of 20000 h

Cantilever force, 1FT7 Compact, AH 80

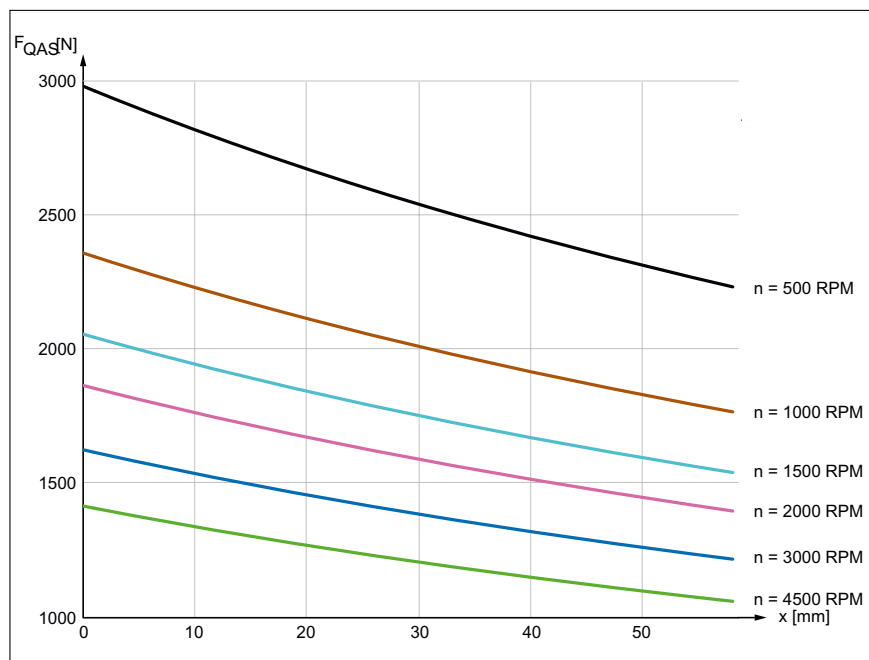

Figure 2-6 Cantilever force F_Q at a distance x from the shaft shoulder for a statistical bearing lifetime of 20000 h

Cantilever force, 1FT7 Compact, AH 100

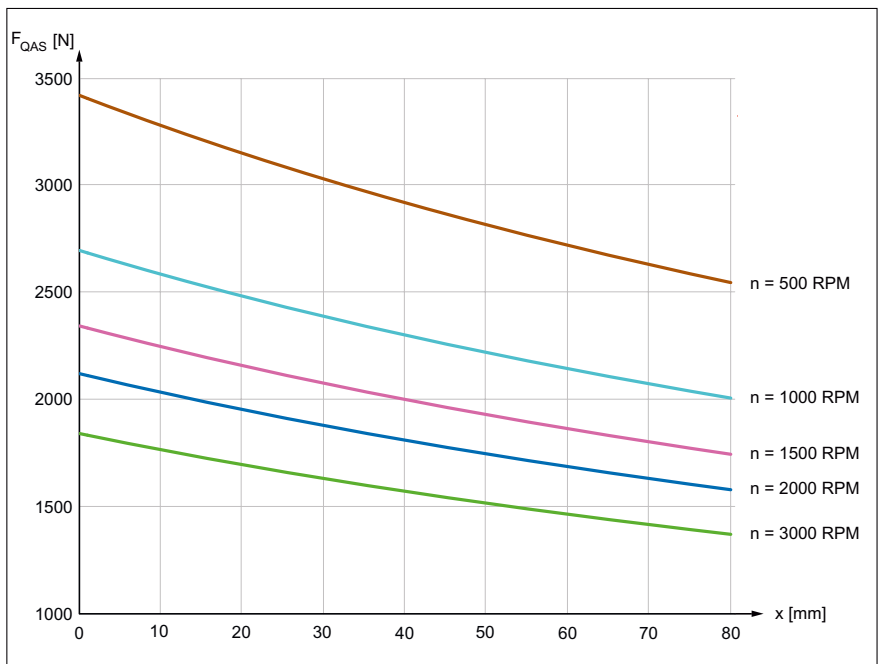

Figure 2-7 Cantilever force F_Q at a distance x from the shaft shoulder for a statistical bearing lifetime of 20000 h

2.1.10 Calculating the belt pre-tension

$$F_R [N] = 2 \cdot M_0 \cdot c / d_R \qquad F_R \leq F_{Qperm}$$

Table 2-7 Explanation of the formula abbreviations

Formula abbreviations	Units	Description
F_R	N	Belt pre-tension
M_0	Nm	Motor stall torque
c	—	Pre-tensioning factor; the pre-tensioning factor is an empirical value from the belt manufacturer. It can be assumed as follows: for toothed belts: $c = 1.5$ to 2.2 for flat belts $c = 2.2$ to 3.0
d_R	m	Effective diameter of the belt pulley

When using other configurations, the actual forces, generated from the torque being transferred, must be taken into account.

2.1.11 Axial force stressing

When using, for example, helical toothed wheels as drive element, in addition to the radial force, there is also an axial force on the motor bearings. For axial forces, the spring-loading of the bearings can be overcome so that the rotor is displaced corresponding to the axial bearing play present:

Shaft height	Displacement
48	Approx. 0.2 mm
63 to 100	Approx. 0.35 mm

An axial force as large as the spring-loading is not permitted (100 ... 500 N). Premature failure is the result when the bearing is not pre-tensioned.

The permissible axial force can be approximately calculated using the following formula:

$$F_A = 0.35 \cdot F_Q$$

 Warning
Motors with integrated holding brake cannot be subject to axial forces!

2.1.12 Brake resistances (armature short-circuit braking)

Function description

For transistor PWM converters, when the DC link voltage values are exceeded or if the electronics fails, then electrical braking is no longer possible. If the drive which is coasting down, can represent a potential hazard, then the motor can be braked by short-circuiting the armature. Armature short-circuit braking should be initiated at the latest by the limit switch in the traversing range of the feed axis.

The friction of the mechanical system and the switching times of the contactors must be taken into account when determining the distance that the feed axis takes to come to a complete stop. In order to avoid mechanical damage, mechanical stops should be located at the end of the absolute traversing range.

For servomotors with integrated holding brake, the holding brake can be simultaneously applied to create an additional braking torque – however, with some delay.

Caution
The drive converter pulses must first be canceled and this actually implemented before an armature short-circuit contactor is closed or opened. This prevents the contactor contacts from burning and eroding and destroying the drive converter.

Warning

The drive must always be operationally braked using the setpoint input. For additional information, refer to the Drive Converter Configuration Manual.

The optimum braking torque of the servomotor in regenerative operation can be obtained using armature short-circuit with a matching external resistor circuit.

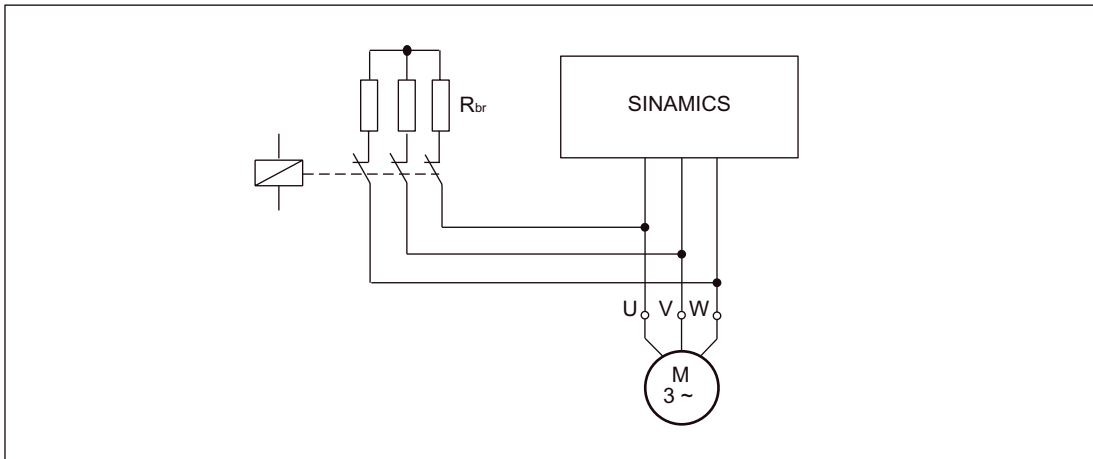

Figure 2-8 Circuit (schematic) with brake resistors

Ordering address

Frizlen GmbH & Co. KG
Gottlieb-Daimler-Str. 61, 71711 Murr
Germany

Phone: +49 (0) 7144 / 8100 - 0
Fax: +40 (0) 7144 / 2076 - 30
E-mail: info@frizlen.com
Internet at: www.frizlen.com

Note

We cannot accept any liability for the quality and properties/features of third-party products.

Rating

The ratings of the resistors must match the particular I²t load capability. The resistors can be dimensioned so that a surface temperature of 300° C can occur briefly (max. 500 ms). In order to prevent the resistors from being destroyed, braking from the rated speed can occur max. every 2 minutes. Other braking cycles must be specified when ordering the resistors. The external moment of inertia and the intrinsic motor moment of inertia are decisive when dimensioning these resistors.

The kinetic energy must be specified when ordering in order to determine the resistor rating.

$$W = \frac{1}{2} \cdot J \cdot \omega^2$$

W	[Ws]
J	[kgm ²]
ω	[s ⁻¹]

Braking time and deceleration distance

The braking time is calculated using the following formula:

Braking time:

$$t_B = \frac{J_{tot} \cdot n_N}{9.55 \cdot M_B}$$

Braking time t_B [s]

Rated speed n_N [RPM]

Moment of inertia:

$$J_{tot} = J_{mot} + J_{ext}$$

Average braking torque M_B [Nm]

Moment of inertia J [kgm²]

Braking distance:

$$s = \frac{1}{2} V_{max} \cdot t_B$$

Braking distance s [m]

Velocity V_{max} [m/s]

Notice

When determining the run-on distance, the friction (taken into account as allowance in M_B) of the mechanical transmission elements and the switching delay times of the contactors must be taken into consideration. In order to prevent mechanical damage, mechanical end stops should be provided at the end of the absolute traversing range of the machine axes.

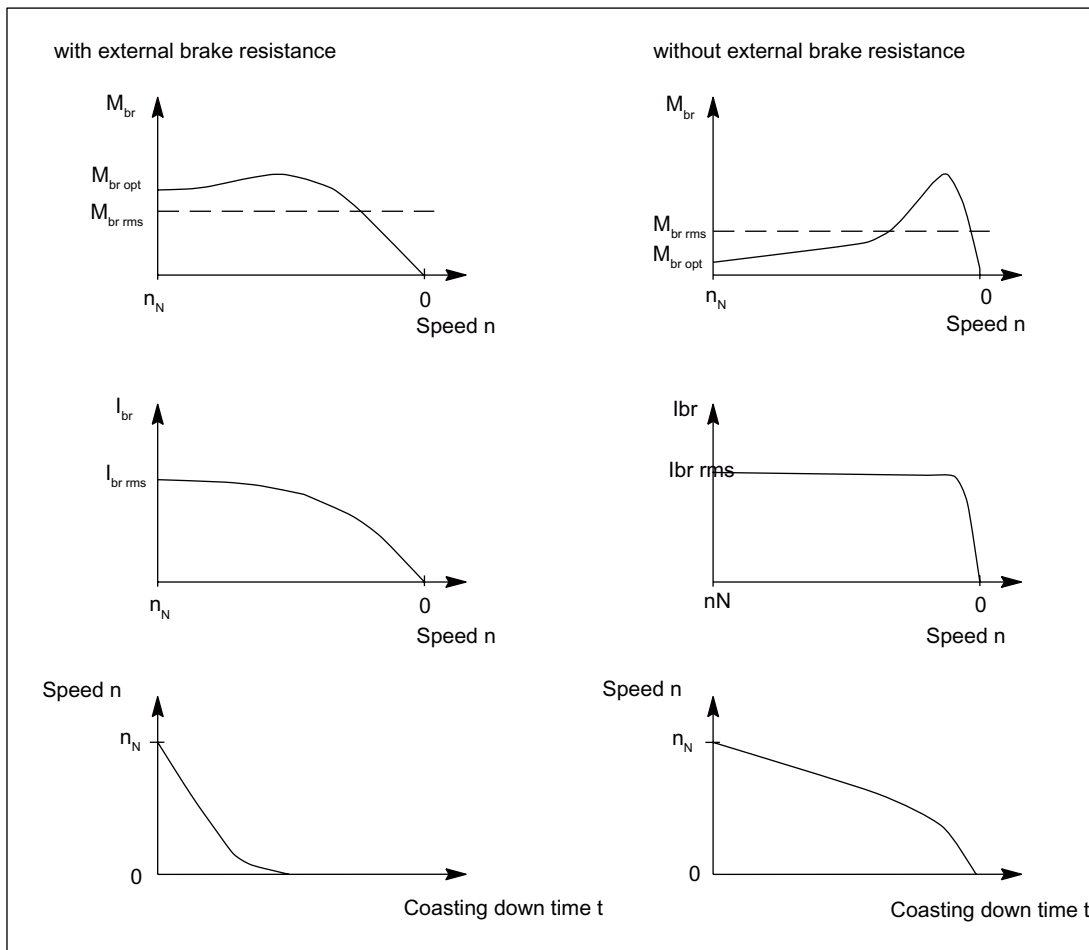

Figure 2-9 Armature short-circuit braking

Dimensioning of braking resistors

The correct dimensioning ensures an optimum braking time. The braking torques which are obtained are also listed in the tables. The data applies for braking from the rated speed and moment of inertia $J_{external} = J_{mot}$. If the drive is braked from another speed, then the braking time cannot be proportionally reduced. However, longer braking times cannot occur if the speed at the start of braking is less than the rated speed.

The data in the following table is calculated for rated values according to the data sheet. The variance during production as well as iron saturation have not been taken into account here. Higher currents and torques can occur than those calculated as a result of the saturation.

Table 2-8 Armature short-circuit braking with/without external braking resistors

Motor type	External braking resistor R_{opt} [Ω]	Average braking torque $M_{Br\ eff}$ [Nm]		Max. braking torque $M_{Br\ max}$ [Nm]	Effective braking current $I_{Br\ eff}$ [A]	
		Without external braking resistor	With external braking resistor		Without external braking resistor	With external braking resistor
Core types						
1FT7044-1AF7	4,8	7,4	10	12,5	13,4	12,2
1FT7062-1AF7	10,4	1,9	4,4	5,4	6,9	6,2
1FT7062-1AK7	5,0	1,2	4,4	5,4	14,6	13,1
1FT7064-1AF7	7,0	3,0	7,3	9,1	11,0	9,9
1FT7064-1AK7	6,1	1,9	7,3	9,1	17,2	15,4
1FT7082-1AF7	6,7	3,0	9,2	11,4	12,8	11,5
1FT7084-1AF7	4,4	4,9	16,5	20,5	21,3	19,1
1FT7084-1AH7	3,2	3,7	16,2	20,1	30,4	27,2
1FT7086-1AF7	2,9	7,2	23,8	29,6	31,4	28,1
1FT7102-1AC7	2,9	9,7	27,3	34,0	27,0	24,2
1FT7105-1AC7	2,1	14,4	51,1	63,5	44,3	39,7
Standard types						
1FT7042-5AF7	6,6	3,3	4,3	5,4	7,4	6,7
1FT7042-5AK7	5,0	2,5	4,5	5,6	13,8	12,4
1FT7044-5AF7	4,8	7,4	10,0	12,5	13,4	12,2
1FT7044-5AK7	3,3	4,6	9,5	11,8	24,9	22,3
1FT7046-5AF7	3,6	9,7	13,7	17,0	18,3	16,6
1FT7046-5AH7	1,6	8,0	13,7	17,0	35,9	32,3
1FT7062-5AF7	10,4	1,9	4,4	5,4	6,9	6,2
1FT7062-5AK7	5,0	1,2	4,4	5,4	14,6	13,1
1FT7064-5AF7	7,0	3,0	7,3	9,1	11,0	9,9
1FT7064-5AK7	6,1	1,9	7,3	9,1	17,2	15,4
1FT7066-5AF7	3,8	4,3	10,7	13,3	17,9	16,0
1FT7066-5AH7	2,5	2,9	10,2	12,7	27,1	24,2
1FT7068-5AF7	4,5	5,7	14,9	18,5	19,6	17,6
1FT7082-5AC7	9,6	4,0	9,2	11,4	8,5	7,6
1FT7082-5AF7	6,7	3,0	9,2	11,4	12,8	11,5
1FT7082-5AH7	3,9	2,3	9,3	11,5	20,9	18,7
1FT7084-5AC7	3,9	6,8	16,4	20,4	17,9	16,0
1FT7084-5AF7	4,4	4,9	16,5	20,5	21,3	19,1
1FT7084-5AH7	3,2	3,7	16,2	20,1	30,4	27,2
1FT7086-5AC7	4,0	9,1	23,8	29,6	21,5	19,3
1FT7086-5AF7	2,9	7,2	23,8	29,6	31,4	28,1
1FT7102-5AB7	4,3	11,5	27,4	34,0	19,0	17,0
1FT7102-5AC7	2,9	9,7	27,3	34,0	27,0	24,2
1FT7102-5AF7	2,3	7,4	27,6	34,3	38,4	34,4

		Average braking torque			Effective braking	
		$M_{Br\text{ eff}}$ [Nm]			current $I_{Br\text{ eff}}$ [A]	
1FT7105-5AB7	2,4	18,1	50,8	63,1	35,1	31,5
1FT7105-5AC7	2,1	14,4	51,1	63,5	44,3	39,7
1FT7105-5AF7	1,7	10,5	49,9	61,9	59,9	53,6
1FT7108-5AB7	2,2	23,9	71,6	89,0	44,4	39,8
1FT7108-5AC7	1,5	20,7	72,5	90,1	62,2	55,7

2.1.13 Drive coupling

Function description

In order to achieve optimum drive-out characteristics, ROTEX® GS couplings supplied by KTR should be used. The advantages of ROTEX® GS couplings include:

- 2 to 4x torsional stiffness of a belt-driven gearbox
- No intermeshing teeth (when compared to belt gearboxes)
- Low moment of inertia
- Good control behavior

They must be optimally harmonized with existing machine masses, the mounted mechanical system, the machine stiffness, etc.

KTR provides assistance in the selection of the coupling.

Ordering address

Address: KTR
Kupplungstechnik GmbH
Rodder Damm 170, D - 48432 Rheine

Postal address: Postfach 1763, D - 48407 Rheine

Phone: +49 (0) 5971 / 798 - 465 (337)

Fax: +49 (0) 5971 / 798 - 450

Internet: www.ktr.com

2.1.14 Storage before use

The motors should be stored indoors in dry, low-dust and low-vibration ($v_{\text{eff}} < 0.2$ mm/s) rooms. The motors should not be stored longer than two years at room temperature (+5° C to +40° C) to retain the service life of the grease.

2.2 Electrical connections

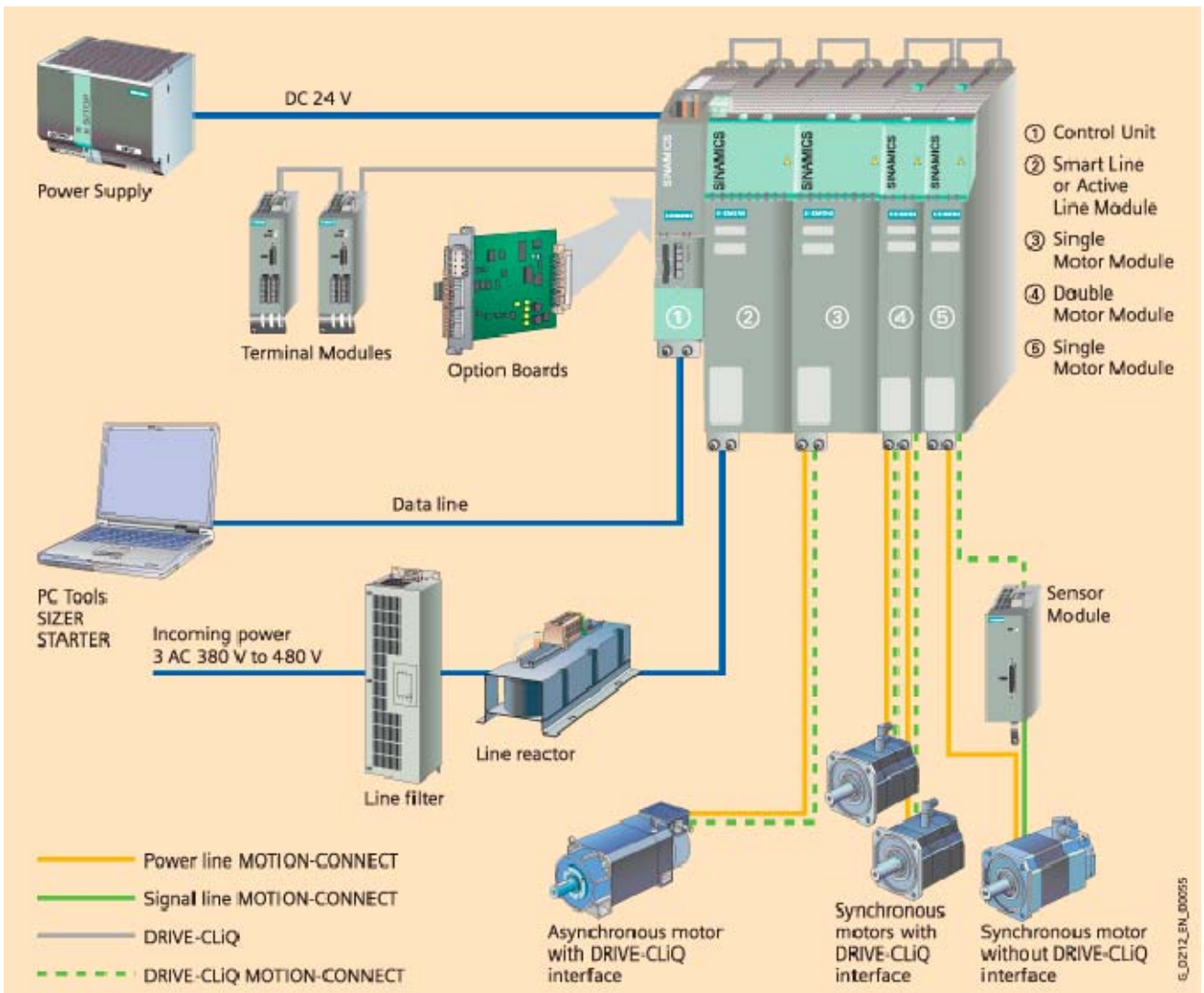



Figure 2-10 SINAMICS S120 system overview

2.2.1 Power connection

 Warning
The motors are not designed to be connected directly to the line supply.

Connection assignment, power connector at the motor

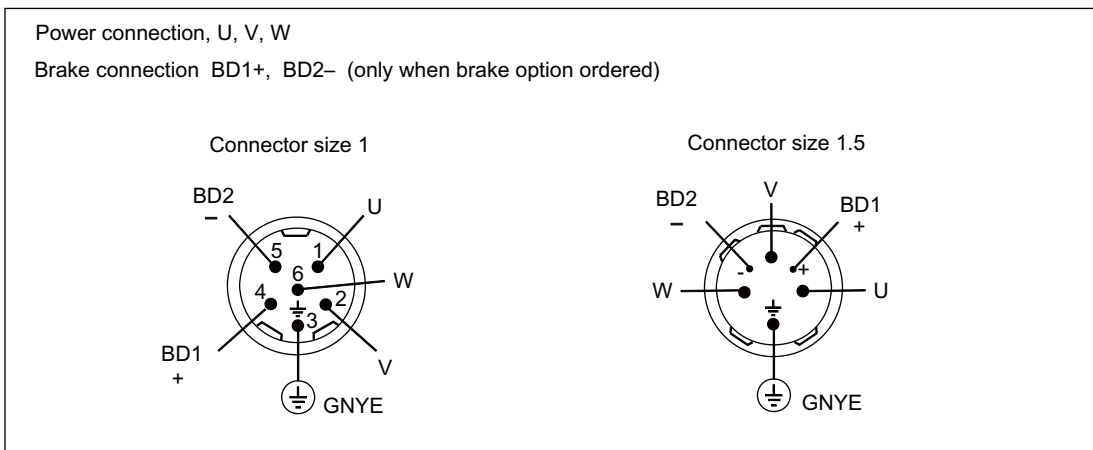

Figure 2-11 Power connection

2.2.2 DRIVE-CLiQ

DRIVE-CLiQ is the preferred method for connecting the encoder systems to SINAMICS.

Motors with a DRIVE-CLiQ interface can be ordered for this purpose. Motors with a DRIVE-CLiQ interface can be directly connected to the associated motor module via the available MOTION-CONNECT DRIVE-CLiQ cables. The MOTION-CONNECT DRIVE-CLiQ cable is connected to the motor in degree of protection IP67. The DRIVE-CLiQ interface supplies power to the motor encoder via the integrated 24 VDC supply and transfers the motor encoder and temperature signals and the electronic type plate data, e.g. a unique identification number, rating data (voltage, current, torque) to the control unit.

The MOTION-CONNECT DRIVE-CLiQ cable is used universally for connecting the various encoder types. These motors simplify commissioning and diagnostics, as the motor and encoder type are identified automatically.

Motors with DRIVE-CLiQ

Motors with DRIVE-CLiQ interfaces can be directly connected to the corresponding motor module via the available MOTION-CONNECT DRIVE-CLiQ cables. This data is transferred directly to the Control Unit.

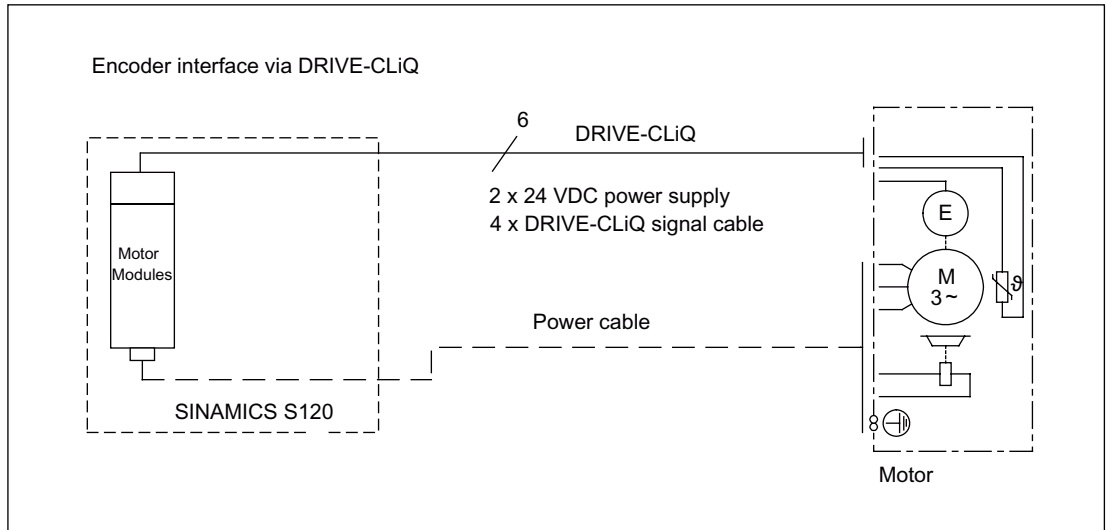

Figure 2-12 Encoder interface with DRIVE-CLiQ

Cables

With DRIVE-CLiQ, the same cable is used for all encoder types. Only prefabricated cables from Siemens (MOTION-CONNECT) may be used.

Table 2-9 Prefabricated cable

6FX	<input type="checkbox"/>	002	-	<input type="checkbox"/> DC <input type="checkbox"/>	-	<input type="checkbox"/> <input type="checkbox"/>	0
	↓					↓↓↓	
	↓					Length	
						max. cable length 100 m	
						max. cable length 50 m	

Motors without DRIVE-CLiQ

Motors without DRIVE-CLiQ require a cabinet-mounted sensor module for operation with SINAMICS S120. The sensor modules evaluate the signals from the connected motor encoders or external encoders and convert them to DRIVE-CLiQ. In conjunction with motor encoders, the motor temperature can also be evaluated using sensor modules. For additional information, refer to the SINAMICS Manual.

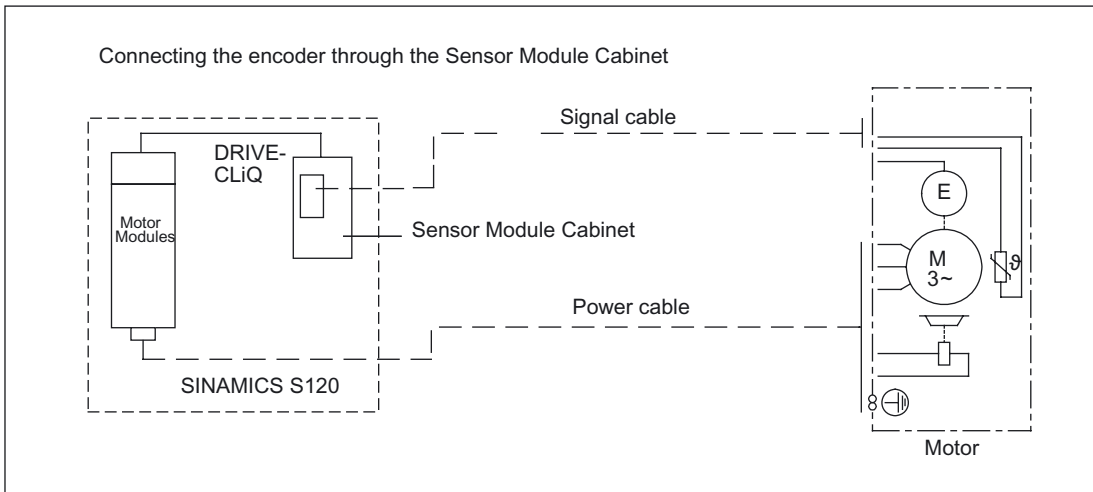

Figure 2-13 Encoder interface without DRIVE-CLiQ

Encoder without DRIVE-CLiQ

Table 2-10 Pin assignment for 17-pin angle plug with pin contacts

PIN No.	Incremental encoders	Absolute encoders	
1	A	A	<p>When viewing the plug-in side (pins)</p>
2	A*	A*	
3	R	data	
4	D*	not connected	
5	C	clock	
6	C*	not connected	
7	M encoder	M encoder	
8	+1R1	+1R1	
9	-1R2	-1R2	
10	P encoder	P encoder	
11	B	B	
12	B*	B*	
13	R*	data*	
14	D	clock*	
15	0 V sense	0 V sense	
16	5 V sense	5 V sense	
17	not connected	not connected	

Cables

Only prefabricated cables from Siemens (MOTION-CONNECT) may be used.

Table 2-11 Pre-assembled cable for incremental encoder

6FX	□	002	-	2CA31	-	□□□	0
	↓	5 MOTION-CONNECT®500 8 MOTION-CONNECT®800				↓↓↓	Length, max. cable length 100 m

Table 2-12 Prefabricated cable for absolute encoder

6FX	□	002	-	2EQ10	-	□□□	0
	↓	5 MOTION-CONNECT®500 8 MOTION-CONNECT®800				↓↓↓	Length, max. cable length 100 m

For other technical data and length code, refer to Catalog, Chapter "MOTION-CONNECT connection system"

2.2.3 Rotating the connector at the motor

Power connector, signal connector and DRIVE-CLiQ can, to some extent, be rotated.

Notice
<ul style="list-style-type: none"> • It is not permissible that the specified rotation range is exceeded. • In order to guarantee the degree of protection, max. 10 revolutions are permissible. • Do not exceed max. torques when rotating. • Connectors should be rotated using the matching mating connector located on the connector thread. • Connecting cables must be secured against tension and bending. • The motor connectors must then be secured so that they cannot rotate. • It is not permissible to subject the connector to continuous force.

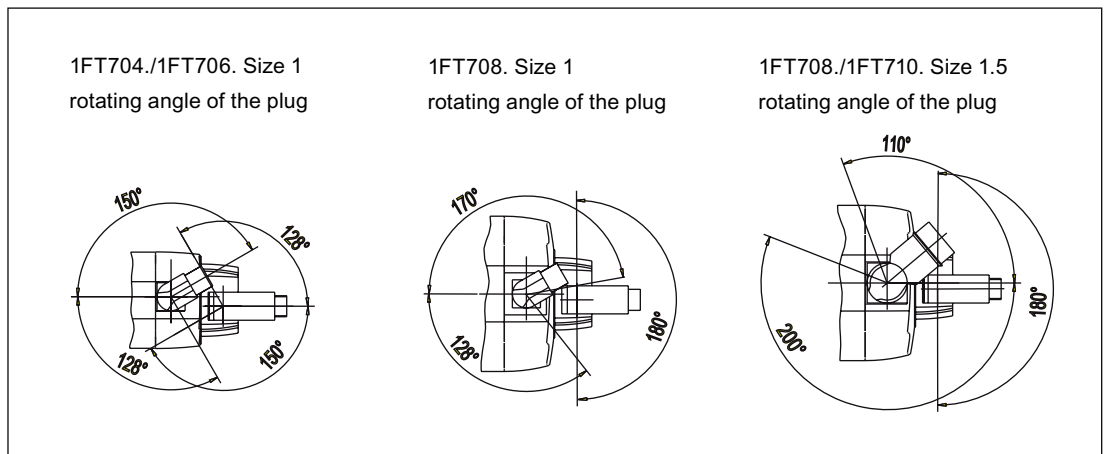

Figure 2-14 Connector direction of rotation and angle of rotation

Table 2-13 Torques when rotating

Connector	Max. torque when rotating [Nm]
Power connector, size 1	8
Power connector, size 1.5	15
Signal connector	8
DRIVE-CLiQ (connector)	8

Mechanical data

Bearing version

The motors have grease-lubricated, deep groove ball bearings (life lubricated). The bearings are sealed at both ends and designed for a minimum ambient temperature in operation of -15°C .

Note

We recommend that the bearings are replaced after approx. 25 000 operating hours, however, at the latest after 5 years.

Shaft end

The drive shaft end is cylindrical in accordance with DIN 748 Part 3, IEC 60072-1. The 1FT7 Compact motors can be ordered with or without keyway. The force-locked shaft-hub coupling is preferred for fast acceleration and reversing operation of the drives.

Smooth running, concentricity and axial eccentricity

The motors are tested in compliance with DIN 42955 (IEC 60072-1).

Vibration severity grade A (acc. to EN 60034-14, IEC 60034-14)

The specified values only refer to the motor. These values can be increased at the motor due to the overall vibration characteristics of the complete system after the drive has been mounted.

The vibration complies with the severity grade up to rated speed.

Balancing (acc. to DIN ISO 8821) for motors with featherkey

Motors with featherkey in the shaft are half-key balanced. A mass equalization for the protruding half key must be taken into account for the output elements.

Electrical data

4.1 Torque-speed characteristic

The permissible operating range is limited by thermal, mechanical, and electromagnetic boundaries.

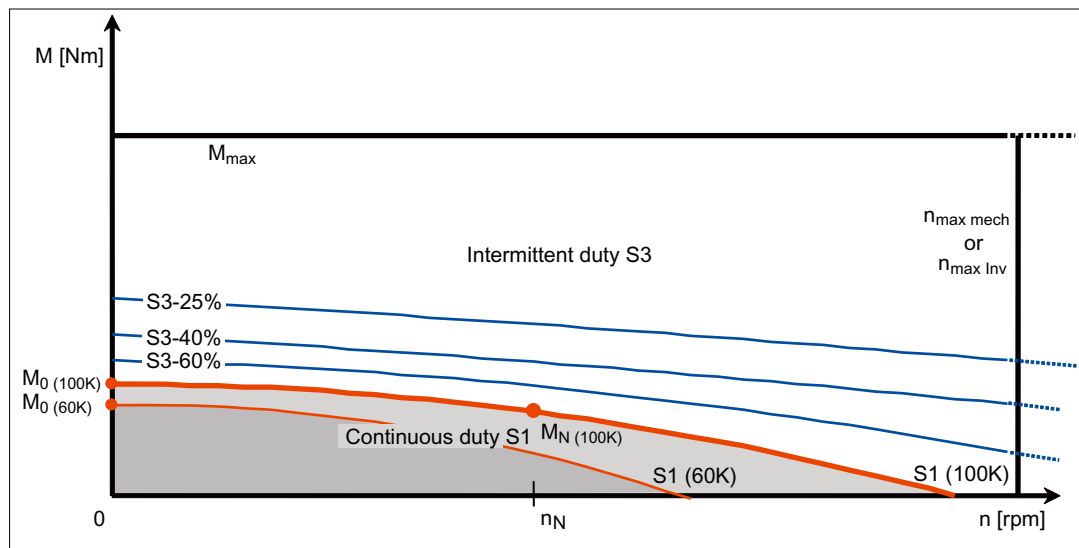

Figure 4-1 Torque characteristics of synchronous motors

Permissible temperature range, 100 K-, 60 K-values

The temperature rise of the motor is caused by the losses generated in the motor (current-dependent losses, no-load losses, friction losses). The utilization of the motor depends on the cooling method (self-cooled, forced ventilation, water-cooled).

155° C corresponds to a utilization according to temperature class 155 (F).

1FT7 Compact motors can be operated up to an average winding temperature of 140° C.

A maximum permissible ambient temperature of 40° C for self-cooled motors generally applies to all specifications.

100 K or 60 K is the average winding temperature rise in Kelvin.

60 K is in the utilization within temperature class 60 (B). The 60 K utilization is used:

- If the temperature of the enclosure/housing must lie below 90° C for safety reasons
- The motor temperature rise would have a negative impact on the machine

4.2 Voltage limiting characteristics

Torque characteristics of motor

The maximum permissible torque is dependent on the permissible overtemperature and, thus, on the mode. To adhere to the temperature limits, the torque must be reduced as the speed increases, starting from static torque M_0 .

The characteristic curves are specified for continuous operation $S1_{(100\text{ K})}$, $S1_{(60\text{ K})}$ and periodic intermittent operation S3-25%, S3-40%, S3-60% with a cycle time of 10 minutes and 100 K overtemperature, except for small motors, for which a cycle time of 1 minute is specified and noted in the characteristic curves.

For more information about the duty cycles, refer to the section on "Dimensioning".

A transient, high overload capacity up to M_{max} is provided over the complete speed setting range.

 Warning
Continuous duty in the area above the S1 characteristic curve is not thermally permitted for the motor.

The speed range is limited by the mechanical limit speed $n_{max\ mech}$ (centrifugal forces at the rotor, bearing service life) or the electrical limit speed $n_{max\ Inv}$ (withstand voltage of the converter or max. frequency of the converter).

4.2 Voltage limiting characteristics

Winding versions

Several winding versions (armature circuit) for different rated speeds n_N are possible within a motor frame size.

Table 4-1 Code letter, winding version

Rated speed n_N [1/min]	Winding version (10. position of the Order No.)
1500	B
2000	C
3000	F
4500	H
6000	K

Converter output voltage

The converter output voltages differ according to the converter type and supply voltage.

Table 4-2 Converter voltages

Converter type	Infeed module	Line voltage	DC link voltage	Output voltage
		U_{supply}	$U_{\text{DC link}}$	U_{mot}
SINAMICS S 120 3AC 380 - 480 V	ALM	400 V	600 V	425 V
	SLM	400 V	528 V	380 V
	SLM	480 V	634 V	460 V

Torque limit for operation on converter without field weakening option

The voltage induced in the motor winding increases as the speed increases. The difference between the DC link voltage of the converter and the induced motor voltage can be used to apply the current.

For converters **without field weakening option**, this limits the amount of applicable current. This causes the torque to drop off quickly at high speeds. All operating points that can be achieved with the motor lie to the left of the voltage limiting characteristic line.

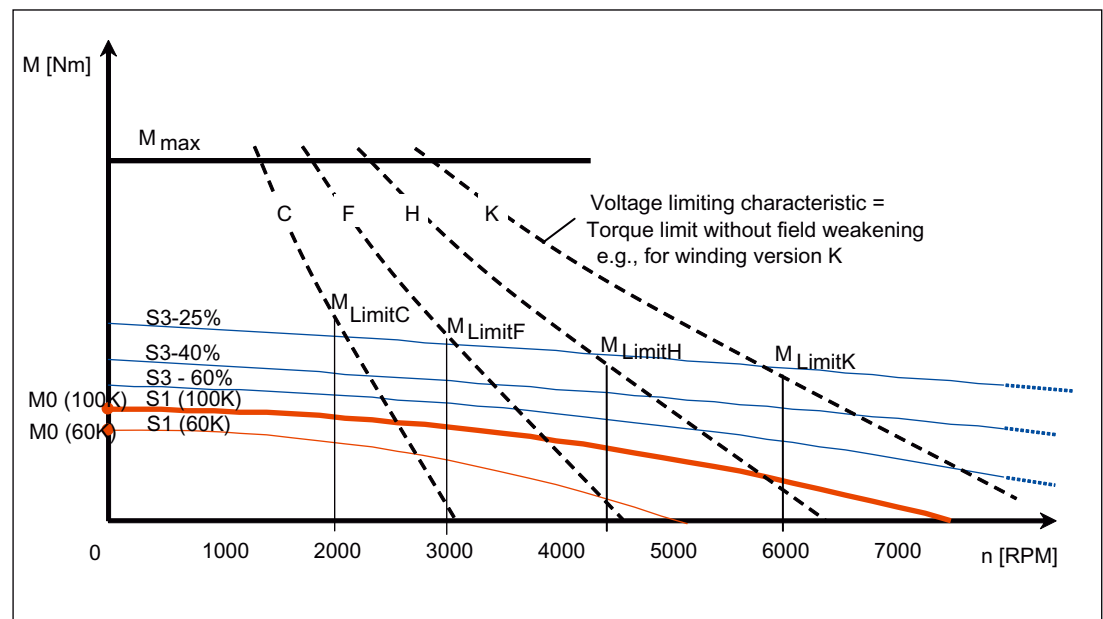

Figure 4-2 Speed-torque diagram, examples for various winding versions

The shape of the voltage limiting characteristic curve is determined by the winding version (armature circuit) and the magnitude of the converter output voltage.

The characteristic curve is plotted for each winding version in a separate data sheet. The torque-speed diagrams for different converter output voltages are then assigned to each data sheet.

For 1FT7 Compact, the voltage limiting characteristics are calculated for a motor at operating temperature.

4.2 Voltage limiting characteristics

Note

The voltage limit characteristic of a motor with 6000 RPM rated speed lies far above that of the same motor type with 2000 RPM. However, for the same torque, this motor requires a significantly higher current.

For this reason, you should select the rated speed such that it does not lie too far above the maximum speed required for the application.

The size (rating) of the converter module (output current) can be minimized in this fashion

Offset of the voltage limit characteristic

Notice

The offset of the voltage limiting characteristic only applies for linear limiting characteristics, e.g. for 1FT7 Compact motors.

In order to identify the limits of the motor for a converter output voltage (U_{mot}) other than 380 V, 425 V, or 460 V, the relevant voltage limiting characteristic curve must be shifted (offset) for the particular new output voltage ($U_{mot, new}$).

The degree of offset is obtained as follows:

For an output voltage of $U_{mot, new}$, an offset is obtained along the X axis (speed) by a factor of:

$$\frac{U_{mot, new}}{U_{mot}} = \frac{U_{mot, new}}{U_{mot}}$$

$U_{mot, new}$ = new converter output voltage
 U_{mot} = drive converter output voltage from the characteristic curve for 380 V, 425 V, or 460 V

Notice

It is only possible to shift the voltage limiting characteristic, if the condition

$$U_{mot, new} > U_{iN}$$

is fulfilled.

The induced voltage U_{iN} is specified on the motor rating plate.

$$U_{iN} = k_E \cdot n_N / 1000$$

Calculating the new limit torque with the new limiting characteristic

$$M_{\text{limit, new}} = \frac{V_{\text{mot, new}} - V_{iN}}{V_{\text{Mot}} - V_{iN}} \cdot M_{\text{limit}}$$

The value M_{limit} is read-off from the limiting characteristic curve for U_{mot} (value at the rated speed).

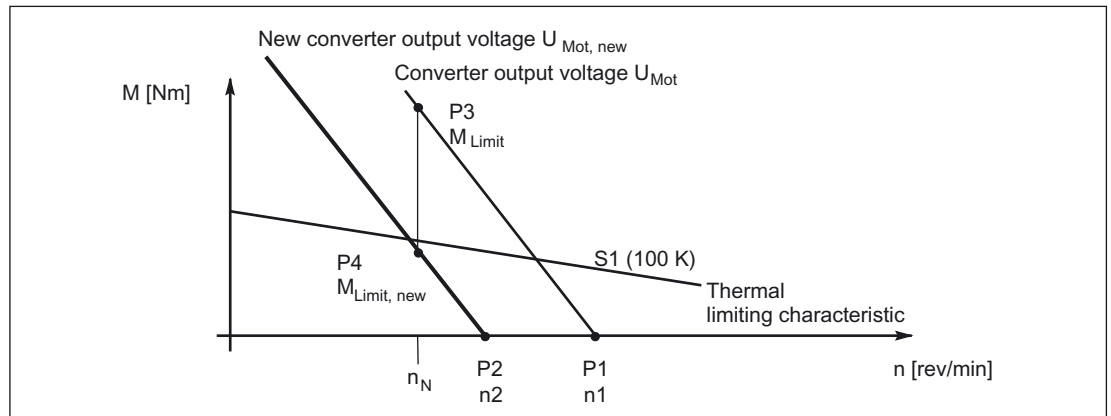

Figure 4-3 Offset of voltage limiting characteristic from U_{mot} to $U_{\text{mot,new}}$

- P1 The voltage limiting characteristic curve specified for U_{mot} intersects with the x-axis (speed) at n_1 [RPM].
- P2 The point where the voltage limiting characteristic intersects with the x axis is shifted from n_1 to n_2 .

$$n_2 [1/\text{min}] = n_1 \cdot \frac{V_{\text{Mot, new}}}{V_{\text{Mot}}}$$

- P3 Read-off M_{limit} on the voltage limiting characteristic curve specified for U_{mot} .
Calculating $M_{\text{limit, new}}$:

$$M_{\text{limit, new}} = \frac{V_{\text{mot, new}} - V_{iN}}{V_{\text{Mot}} - V_{iN}} \cdot M_{\text{limit}}$$

- P4 $M_{\text{limit, new}}$
The offset voltage limiting characteristic curve is obtained with points P2 and P4.

Example of offset of voltage limiting characteristic curve without field weakening

Motor 1FT7042-5AF71; $n_N = 3000$ RPM; $k_E = 87$ V/1000 RPM

$U_{mot, new} = 290$ V; calculated with $U_{mot} = 380$ V

$U_{iN} = k_E \cdot n_N/1000$; $U_{iN} = 87 \cdot 3000/1000 = 261$ V

Condition $U_{mot, new} > U_{iN}$ is fulfilled.

Calculation P1: $"n_1" = \frac{380}{87} \cdot 1000$ RPM = 4368 RPM

Calculation P2: $"n_2" = \frac{290}{380} \cdot 4368$ RPM = 3333 RPM

Calculation P3: M_{Limit} For = 380 V and $"n_N" = 3000$ Read RPM for 380 V

Calculation P4: $M_{Limit, new} = \frac{290 - 261}{380 - 261} \cdot 8.8$ Nm = 2.14 Nm

Enter and connect points P2 and P4. This line is the new drive converter output voltage $V_{mot, new}$.

4.3 Field weakening mode

The SINAMICS S120 converter injects a field weakening current which means that the motor can operate above the voltage limiting characteristic without field weakening. The method used by the converter to inject the field weakening current has a significant influence on the curve characteristic.

Torque limit for operation on converter with field weakening option

The characteristics shown apply to operation on a SINAMICS S120 converter.

Field weakening mode is always active on a SINAMICS S120 converter.

The shape of the characteristics in field weakening mode depends on the position of the voltage limiting characteristic. A torque/speed chart is therefore assigned to each voltage limiting characteristic.

4.4 Definitions

Rated speed n_N

The characteristic speed range for the motor is defined in the speed-torque diagram by the rated speed.

Number of poles $2p$

Number of magnetic north and south poles on the rotor. p is the number of pole pairs.

Rated torque M_N

Thermally permissible continuous torque in S1 duty at the rated motor speed.

Rated current I_N

RMS motor phase current for generating the particular rated torque.
Specification of the RMS value of a sinusoidal current.

Static torque M_0

Thermal limit torque at motor standstill corresponding to a utilization according to 100 K or 60 K. This can be output for an unlimited time when $n = 0$. M_0 is always greater than the rated torque M_N .

Stall current I_0

Motor phase current for generating the particular static torque.
Specification of the RMS value of a sinusoidal current.

Moment of inertia J_{mot}

Moment of inertia of rotating motor parts.

Optimum operating point

Operating point at which the maximum continuous output of the motor is normally provided at high efficiency (see figure below).

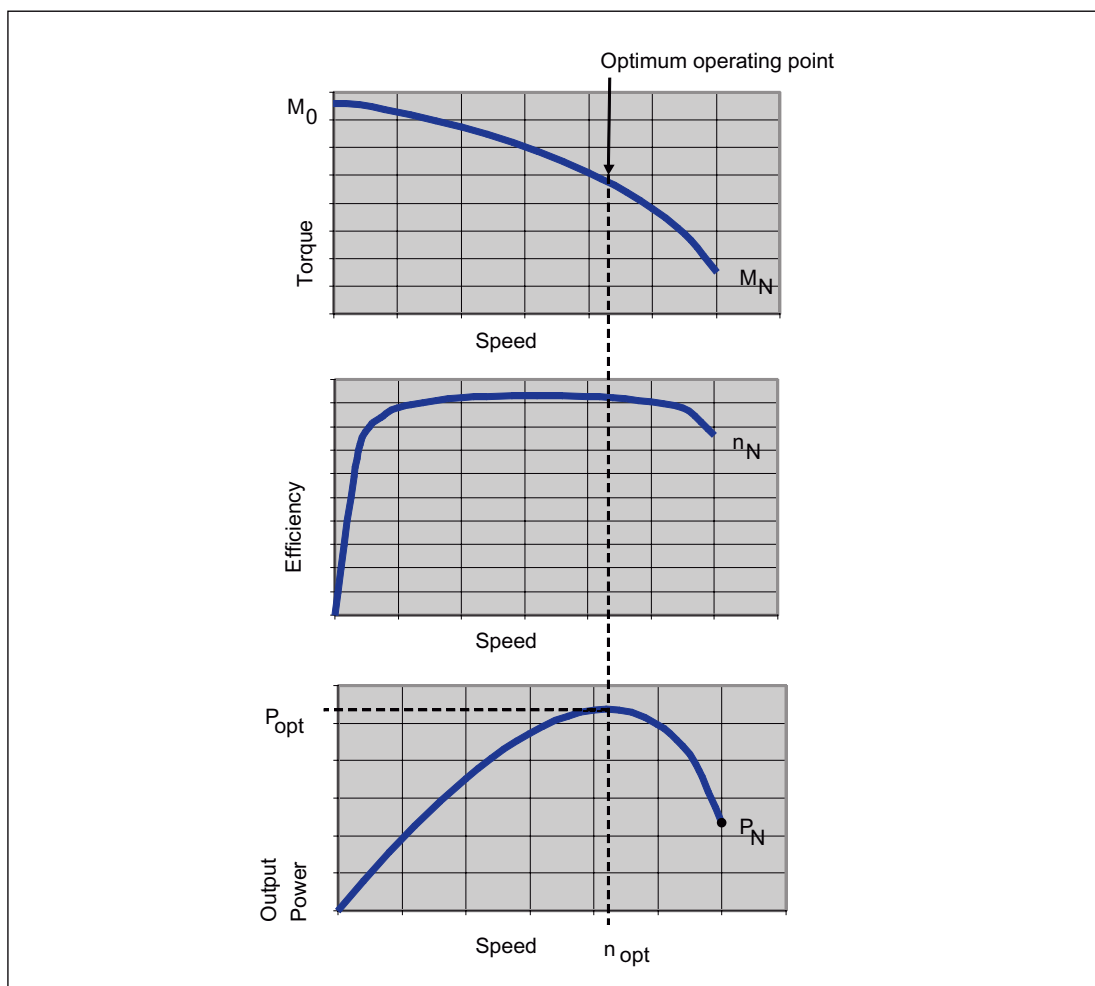

Figure 4-5 Optimum operating point

Optimum speed n_{opt}

Speed at which the optimum motor power is output.

If the rated speed is less than the optimum speed, the rated speed is output.

Optimum power P_{opt}

Power achieved at the optimum speed.

The rated speed is the optimum speed (see optimum speed), the optimum power corresponds to the rated power.

Maximum speed n_{max}

The maximum permissible mechanical operating speed n_{max} is the lesser of the maximum mechanically permissible speed and the maximum permissible speed at the converter.

Maximum permissible speed (mechanical) n_{max} .

The maximum mechanically permissible speed is $n_{max\ mech}$. It is defined by the centrifugal forces and frictional forces in the bearing.

Maximum permissible speed at converter $n_{max\ Inv}$

The maximum permissible operating speed for operation at a converter is $n_{max\ Inv}$ (e.g. limited by withstand voltage, maximum frequency).

Maximum torque M_{max}

Torque that is generated at the maximum permissible current.

The maximum torque is briefly available for high-speed operations (dynamic response to quickly changing loads).

The maximum torque is limited by the closed-loop control parameters. If the current is increased, then the rotor will be de-magnetized.

Max. current $I_{max, RMS}$

This current limit is only determined by the magnetic circuit. Even if this is briefly exceeded, it can result in an irreversible de-magnetization of the magnetic material. Specification of the RMS value of a sinusoidal current.

Torque constant k_T (value for a 100 K average winding temperature rise)

Quotient obtained from the static torque and stall current.

Calculation: $k_T = M_{0, 100\ K} / I_{0, 100\ K}$

The constant applies up to approx. $2 \cdot M_{0, 60\ K}$ in the case of self-cooled motors

Note

This constant is not applicable when configuring the necessary rated and acceleration currents (motor losses!).

The steady-state load and the frictional torques must also be included in the calculation.

Voltage constant k_E (value at 20° C rotor temperature)

Value of the induced motor voltage at a speed of 1000 RPM and a rotor temperature of 20° C.

The phase-to-phase RMS motor terminal voltage is specified for 1FT7 Compact motors.

Winding resistance R_{ph} at 20° C winding temperature

The resistance of a phase at a winding temperature of 20° C is specified. The winding has a star circuit configuration.

Cyclic inductance L_D

The cyclic inductance is the sum of the air gap inductance and leakage inductance relative to the single-strand equivalent circuit diagram. It consists of the self-inductance of a phase and the coupled inductance to other phases.

Electrical time constant T_{el}

Quotient obtained from the rotating field inductance and winding resistance. $T_{el} = L_D/R_{ph}$

Mechanical time constant T_{mech}

The mechanical time constant is obtained from the tangent at a theoretical ramp-up function through the origin.

$$T_{mech} = 3 \cdot R_{ph} \cdot J_{mot}/k_T^2 \text{ [s]}$$

J_{mot} = Servomotor moment of inertia [kgm²]

$R_{ph.}$ = Phase resistance of the stator winding [Ohm]

k_T = Torque constant [Nm/A]

Thermal time constant T_{th}

Defines the increase in the motor frame temperature when the motor load is suddenly increased (step function) to the permissible S1 torque. The motor has reached 63% of its final temperature after T_{th} .

Shaft torsional stiffness c_T

This specifies the shaft torsional stiffness from the center of the rotor laminated core to the center of the shaft end.

Rated converter current $I_{N Inv}$

RMS converter output current (per phase) that can be supplied on a continuing basis by the recommended motor module. The recommended motor module is selected such that $I_{N Inv}$ is greater than the stall current $I_{0 (100K)}$.

Maximum converter current $I_{max Inv}$

RMS converter output current (per phase) that can be supplied temporarily by the recommended motor module

Maximum torque (limited by converter) $M_{max Inv}$

The maximum torque that can be applied (temporarily) for operation on the recommended motor module.

Typical M/I characteristic

The torque can be calculated linearly from the current, but is subject to conditions (saturation effects, etc.)

The left characteristic curve is regarded as the "best case", and the right characteristic curve as the "worst case".

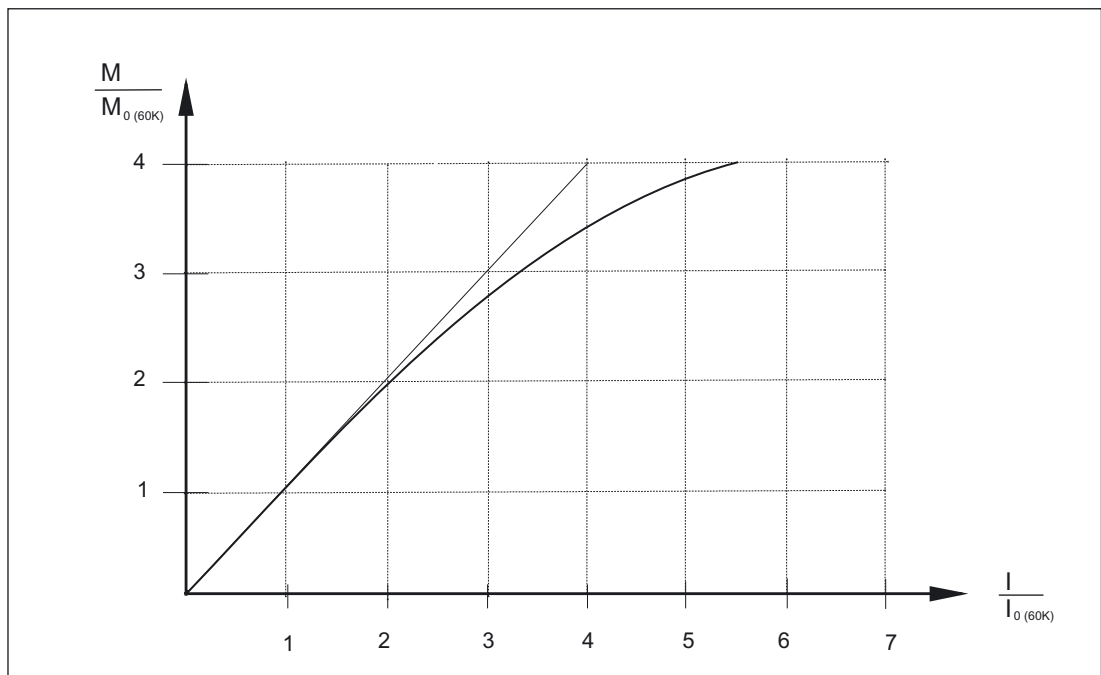

Figure 4-6 Torque-current characteristic curve for self-cooled motors

Braking resistance R_{opt}

R_{opt} corresponds to the optimum resistance value per phase that is switched in series external to the motor winding for the armature short-circuit braking function.

Braking torque $M_{br eff}$

$M_{br eff}$ corresponds to the average braking torque for armature short-circuit braking that is achieved through the upstream braking resistor R_{opt} .

Tolerance data

(data going beyond this is subject to a specific measuring accuracy)

Table 4-3 Tolerance data in the motor list data

Motor list data		Typ. value	Theoretical value
Stall current	I_0	$\pm 3 \%$	$\pm 7,5 \%$
Electrical time constant	T_{el}	$\pm 5 \%$	$\pm 10 \%$
Torque constant	k_T	$\pm 3 \%$	$\pm 7,5 \%$
Voltage constant	k_E	$\pm 3 \%$	$\pm 7,5 \%$
Winding resistance	$R_{ph.}$	$\pm 5 \%$	$\pm 10 \%$
Moment of inertia	J_{mot}	$\pm 2 \%$	$\pm 10 \%$

Engineering software

5.1 SIZER engineering tool

Overview

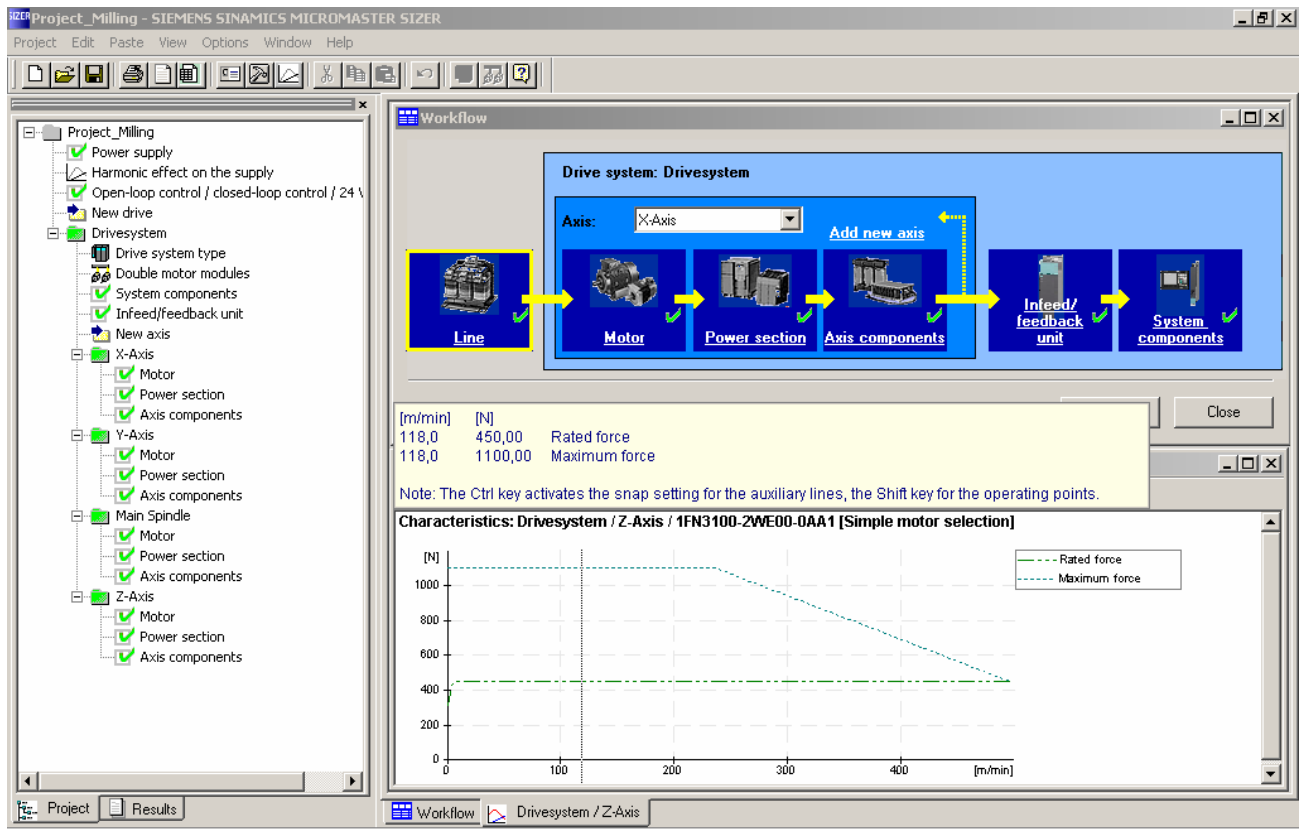

Figure 5-1 SIZER

The SIZER configuration tool provides an easy-to-use means of configuring the SINAMICS and MICROMASTER 4 drive families, as well as the SINUMERIK solution line CNC control and SIMOTION Motion Control system. It provides support when setting up the technologies involved in the hardware and firmware components required for a drive task. SIZER supports the configuration of the complete drive system, from simple individual drives to complex multi-axis applications.

SIZER supports all of the engineering steps in a workflow:

- Selection of the power supply
- Motor design as a result of load configuring
- Calculation of the drive components
- Compiling the required accessories
- Selection of the line-side and motor-side power options

When SIZER was being designed, particular importance was placed on a high degree of usability and a universal, function-based approach to the drive application. The extensive user navigation makes it easy to use the tool. Status information keeps you continually informed about how engineering is progressing.

The SIZER user interface is available in German and English. The drive configuration is saved in a project. In the project, the components and functions used are displayed in a hierarchical tree structure. The project view permits the configuration of drive systems and the copying/inserting/modifying of drives already configured.

The configuration process produces the following results:

- A parts list of the components required
- Technical data
- Characteristics
- Comments on system reaction
- Location diagram and dimension drawings

These results are displayed in a results tree and can be reused for documentation purposes. User support is provided by technological online help, which provides the following information:

- Detailed technical data
- Information about the drive systems and their components
- Decision-making criteria for the selection of components.

Minimum hardware and software requirements

- PG or PC with Pentium™ II 400 MHz (Windows™ 2000), Pentium™ III 500 MHz (Windows™ XP)
- 256 MB RAM (512 MB recommended)
- At least 1150 MB free hard disk space, additional 100 MB free hard disk space on Windows system drive
- Monitor resolution, 1024×768 pixels
- Windows™ 2000 SP2, XP Professional SP1, XP Home Edition SP1
- Microsoft Internet Explorer 5.5 SP2

Selection and ordering data

Title	Order No. (MLFB)
Engineering tool	6SL3070-0AA00-0AG0
SINAMICS MICROMASTER SIZER	
German/English	

5.2 STARTER drive/commissioning software

Overview

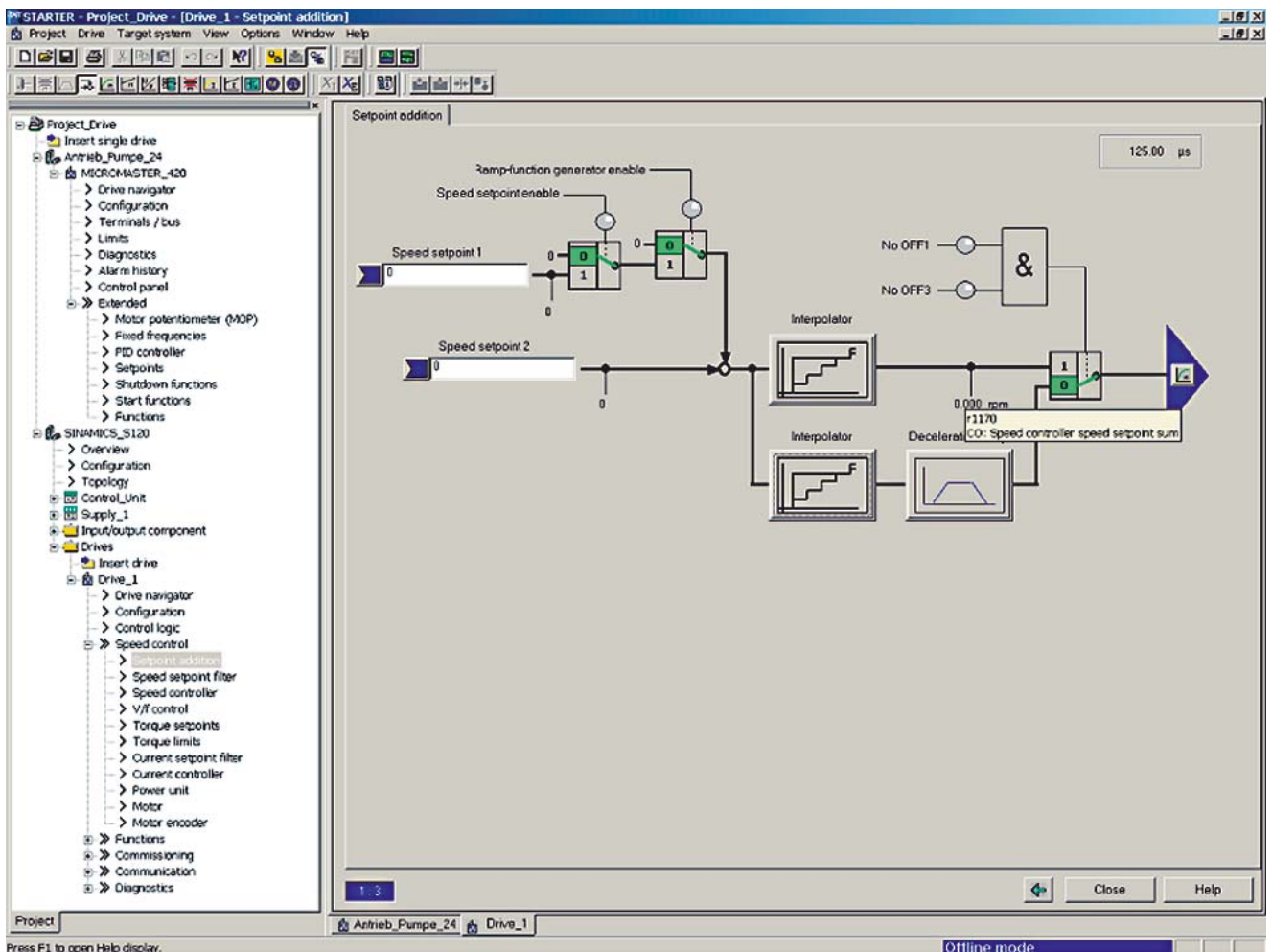

Figure 5-2 STARTER

The easy-to-use STARTER drive/commissioning tool can be used for:

- Commissioning,
- Optimization, and
- Diagnostics

This software can be operated either as a standalone PC application or can be integrated into the SCOUT engineering system (with SIMOTION) or STEP 7 (with Drive ES Basic). The basic functions and handling are the same regardless.

In addition to the SINAMICS drives, the current version of STARTER also supports MICROMASTER 4 devices and frequency converters for the SIMATIC ET 200S FC distributed I/O system.

The project wizards can be used to create the drives within the structure of the project tree.

Entry-level personnel are supported by solution-based dialog navigation, whereby a standard graphics-based display maximizes clarity when setting the drive parameters.

Wizards are used to navigate users when drives are being commissioning for the first time; these Wizards make all of the basic settings in the drive. This enables a drive to be up and running after only setting a small number of parameters within the drive configuration process.

The individual settings required are made using graphics-based parameter assignment screen forms, which also display the mode of operation.

Examples of individual settings that can be made include:

- Terminals
- bus interface
- Setpoint channel (e.g. fixed setpoints)
- Closed-loop speed control (e.g. ramp-function generator, limits)
- BICO interconnections
- Diagnostics.

Experts can gain rapid access to the individual parameters using the Expert List - this means that they do not have to navigate dialogs.

In addition, the following functions are available for optimization purposes:

- self-optimization
- Trace (depending on drive)

Diagnostics functions provide information about:

- Control/status words
- parameter status
- Operating conditions
- Communication states.

Features

- Easy-to-use: Only a small number of settings need to be made for successful first commissioning: Axis rotates
- Solution-based user navigation simplifies commissioning
- Self-optimization functions reduce manual optimization work
- The built-in trace function provides optimum support during commissioning, optimization and troubleshooting.

Minimum hardware and software requirements

- PG or PC with Pentium™ II 400 MHz (Windows™ NT/2000), Pentium™ III 500 MHz (Windows™ XP)
- 256 MB RAM
- Monitor resolution, 1024×768 pixels
- Windows™ NT 4.0 SP6, 2000 SP3, XP Professional SP1
- Microsoft Internet Explorer 5.01

Selection and Ordering Data

Title	Order No. (MLFB)
STARTER commissioning tool for SINAMICS and MICROMASTER German / English / French / Italian	6SL3072-0AA00-0AG0

5.3 Engineering System Drive ES

Overview

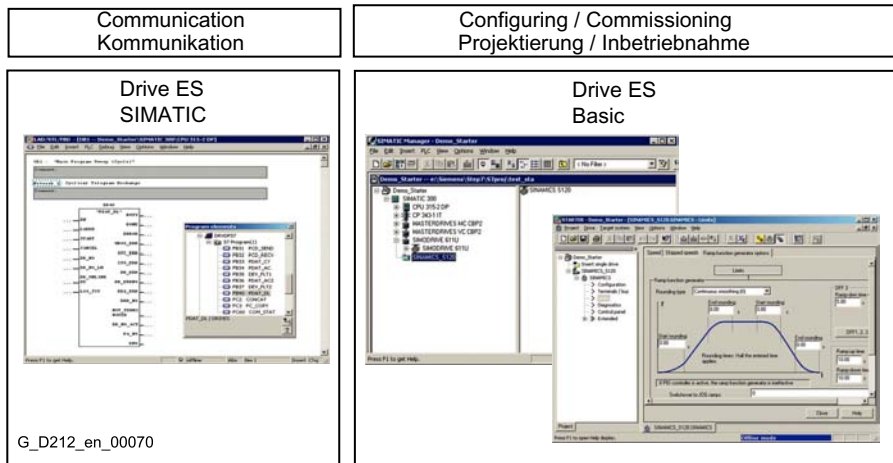

Figure 5-3 Drive ES

Drive ES is the engineering system used to integrate Siemens drive technology into the SIMATIC automation world easily, efficiently and cost-effectively in terms of communication, configuration and data management. The STEP 7 Manager user interface provides the basis for this procedure.

Various software packages are available for SINAMICS S120:

Drive ES Basic

For entry into the world of Totally Integrated Automation and the possibility of using routing beyond network boundaries and also SIMATIC teleservice.

Drive ES Basic is the basic software to parameterize all of the drives both online and offline.

Using Drive ES Basic, the automation and the drives are processed on the SIMATIC Manager screen. Drive ES Basic is the starting point for common data archiving for complete projects and for extending the use of the SIMATIC teleservice to drives. Drive ES Basic provides the engineering tools for the new motion control functions - peer-to-peer data traffic, equidistance and isochronous operation with PROFIBUS DP.

Drive ES SIMATIC

Easy parameter assignment of the STEP 7 communications program instead of programming.

Drive ES SIMATIC requires that STEP 7 has first been installed. It incorporates a SIMATIC block library; this means that the PROFIBUS interface can be simply and reliably programmed in the SIMATIC CPU for the drives.

The separate, time consuming programming of the data exchange functions between the SIMATIC CPU and the drive is eliminated.

For Drive ES users, it is as simple as this:

Copy – Adapt – Load – Ready.

Harmonized, proven function blocks are transferred from the library into your project.

Frequently required functions are completely programmed:

- Complete diagnostic buffers are automatically read from the drive
- Complete parameter sets are automatically downloaded into the drive from the SIMATIC CPU – e.g. when a device has to be replaced.
- Part parameter sets (e.g. for recipe and product change) are automatically downloaded into the drive from the SIMATIC CPU
- Complete parameter assignment or partial parameter sets are uploaded from the drive into the SIMATIC CPU, i.e. updated.

Drive ES PCS 7

integrates drives with PROFIBUS interface into the SIMATIC PCS 7 process control system.

Drive ES PCS 7 requires a pre-installed SIMATIC PCS 7 process control system from Version 5.2 onwards. Drive ES PCS 7 provides a function block library with function blocks for the drives and the corresponding faceplates for the operator station. This means that the drives can be operated from the PCS 7 process control system.

For further information please visit us on the Internet at:

<http://www.siemens.com/drivesolutions>

Selection and Ordering Data

Table 5-1 Selection and ordering data for Drive ES engineering system

Description	Order No. (MLFB)
Drive ES Basic V 5.4	
<ul style="list-style-type: none"> • Engineering software for integration of drives into Totally Integrated Automation • Prerequisites: STEP 7 V 5.3 SP 3, or higher • Form of delivery: on CD-ROM ge, en, fr, sp, it with electronic documentation 	
Single license	6SW1700-5JA00-4AA0
Multi-user license, 60x	6SW1700-5JA00-4AA1
Update service for single-user license	6SW1700-0JA00-0AB2
Update service for multi-user license	6SW1700-0JA00-1AB2
Upgrade from V 5.x to V 5.4	6SW1700-5JA00-4AA4
Drive ES SIMATIC V 5.4	
<ul style="list-style-type: none"> • Block library for SIMATIC for parameter assignment for communication with the drives • Prerequisites: STEP 7 V 5.3 SP 3, or higher • Form of delivery: on CD-ROM ge, en, fr, sp, it with electronic documentation 	
Single-user license incl. 1 x runtime license	6SW1700-5JC00-4AA0
Runtime License	6SW1700-5JC00-1AC0
Update service for single-user license	6SW1700-0JC00-0AB2
Upgrade from V 5.x to V 5.4	6SW1700-5JC00-4AA4
Drive ES PCS 7 V 6.1	
<ul style="list-style-type: none"> • Block library for PCS 7 for integration of drives • Prerequisites: PCS 7 V 6.1 or higher • Form of delivery: on CD-ROM ge, en, fr, sp, it with electronic documentation 	
Single-user license incl. 1 x runtime license	6SW1700-6JD00-1AA0
Runtime License	6SW1700-5JD00-1AC0
Update service for single-user license	6SW1700-0JD00-0AB2
Upgrade from V 5.x to V 6.1	6SW1700-6JD00-1AA4

5.4 Procedure when engineering

The function description of the machine provides the basis when engineering the drive application. The definition of the components is based on physical interdependencies and is usually carried-out as follows:

Step	Description of the engineering activity	Refer to Chapter
1.	Clarification of the type of drive	5.3.1
2.	Definition of the load, calculation of max. load torque	5.3.2
3.	Specification of the motor	5.3.3
4.	The SINAMICS Motor Module is selected	Refer to the converter catalog
5.	Steps 3 and 4 are repeated for additional axes	
6.	The required DC link power is calculated and the SINAMICS Line Module is selected	
7.	Specification of the required control performance and selection of the Control Unit, definition of component cabling	
8.	The line-side options (main switch, fuses, line filters, etc.) are selected	
9.	Additional system components are defined and selected	
10.	The current demand of the 24 V DC supply for the components is calculated and the power supplies (SITOP devices, control supply modules) specified	
11.	The components for the connection system are selected	
12.	The components of the drive group are configured to form a complete drive	
13.	Required cable cross sections for power supply and motor connections	
14.	Mandatory installation clearances	

Configuration begins with the mechanical interface to the machine. A suitable motor is selected according to the specified torques and speeds. A matching power unit is then also chosen. Depending on the requirements of the machine, the motor is supplied as a single drive via a Power Module or within a multi-motor drive group via a Motor Module. Once the basic components have been defined, the system components for matching to the electrical and mechanical interfaces are selected.

The SIZER configuring tool helps the user to select the correct components quickly and easily. The user enters the relevant torque and speed characteristics and SIZER then guides him confidently through the configuring process, identifying suitable motors and matching SINAMICS power units and other system components.

5.4.1 1. Clarification of the type of drive

The motor is selected on the basis of the required torque, which is defined by the application, e.g. traveling drives, hoisting drives, test stands, centrifuges, paper and rolling mill drives, feed drives or main spindle drives. Gear units to convert motion or to adapt the motor speed and motor torque to the load conditions must also be considered.

As well as the load torque, which is determined by the application, the following mechanical data is among those required to calculate the torque to be provided by the motor:

- Masses moved
- Diameter of the drive wheel/diameter
- Leadscrew pitch, gear ratios
- Frictional resistance
- Mechanical efficiency
- Traversing paths
- Maximum velocity
- Maximum acceleration and maximum deceleration
- Cycle time

You must decide whether synchronous or induction motors are to be used.

Synchronous motors are the best choice if it is important to have low envelope dimensions, low rotor moment of inertia and therefore maximum dynamic response ("Servo" control type).

Induction motors can be used to increase maximum speeds in the field weakening range. Induction motors for higher power ratings are also available.

The following factors are especially important when engineering a drive application:

- The line system configuration, when using specific types of motor and/or line filters on IT systems (non-grounded systems)
- The ambient temperatures and the installation altitude of the motors and drive components.
- The utilization of the motor in accordance with rated values for winding temperatures of 60 K or 100 K.

The motor-specific limiting characteristics provide the basis for defining the motors.

These define the torque or power characteristic versus the speed and take into account the motor limits based on the DC-link voltage of the power or motor module.

The DC-link voltage, in turn, is dependent on the supply voltage and, with multi-motor drives, on the type of the line module.

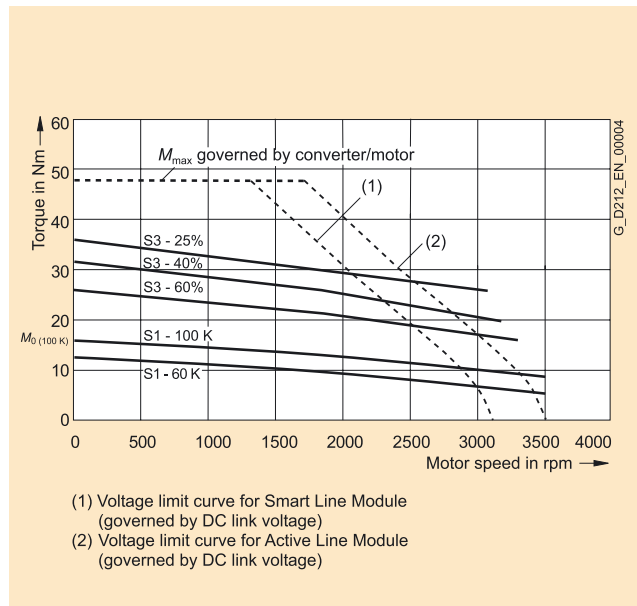

Figure 5-4 Limiting characteristics for synchronous motors (example)

5.4.2 2. Definition of the load event, calculation of max. load torque

Load duty cycles

The motor is selected based on the load which is specified by the application. Different characteristic curves must be used for different load events.

The following operating scenarios have been defined:

- Load duty cycle with constant ON period
- Load duty cycles with varying ON period
- Free duty cycle

The objective is to identify characteristic torque and speed operating points, on the basis of which the motor can be selected depending on the particular load.

Once the operating scenario has been defined and specified, the maximum motor torque is calculated. Generally, the maximum motor torque is required when accelerating. The load torque and the torque required to accelerate the motor are added.

The maximum motor torque is then verified with the limiting characteristic curves of the motors.

The following criteria must be taken into account when selecting the motor:

- The dynamic limits must be adhered to, i.e., all speed-torque points of the relevant load event must lie below the relevant limiting characteristic curve.

- The thermal limits must be adhered to, i.e. for synchronous motors, the RMS motor torque at the average motor speed resulting from the duty cycle must lie below the S1 characteristic curve (continuous duty). For induction motors, the RMS value of the motor current within a duty cycle must be less than the rated motor current.
- It should be noted that the maximum permissible motor torque on synchronous motors at higher speeds is reduced as a result of the voltage limiting characteristic. In addition, a margin of 10% below the voltage limiting characteristic should be maintained to safeguard against voltage fluctuations.
- When using induction motors, the permissible motor torque in the field-weakening range is restricted by the voltage limiting characteristic (stability limit). A margin of 30 % should be observed.

Load duty cycles with constant on period

For duty cycles with constant ON period, there are specific requirements for the torque characteristic curve as a function of the speed:

e.g. $M = \text{constant}$, $M \sim n^2$, $M \sim n$ or $P = \text{constant}$.

These drives typically operate at a specific operating point. Drives such as these are dimensioned for a base load. The base load torque must lie below the S1 characteristic curve.

In the event of transient overloads (e.g. when accelerating) an overload has to be taken into consideration. The peak torque must lie below the voltage limiting characteristic curve for synchronous motors or below the stability limit for induction motors.

In summary, the motor is selected as follows:

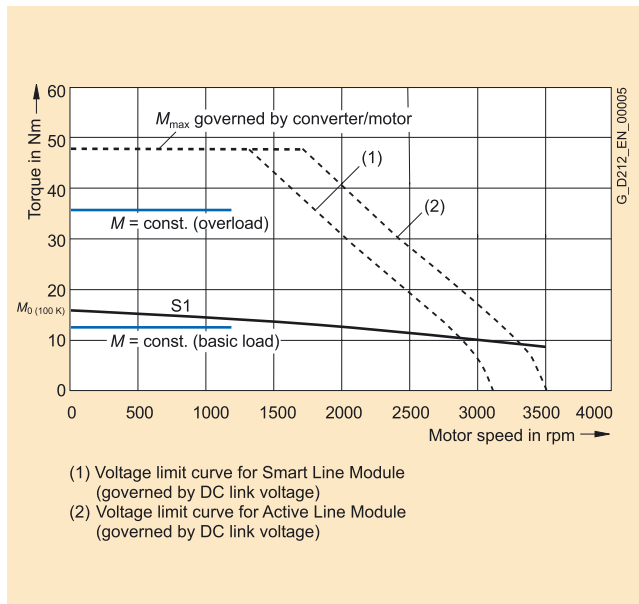

Figure 5-5 Selection of motors for load duty cycles with constant on period (examples)

Load duty cycles with varying on period

As well as continuous duty (S1), standard intermittent duty types (S3) are also defined for load duty cycles with varying on periods. This involves operation that comprises a sequence of similar load cycles, each of which comprises a time with constant load and an off period.

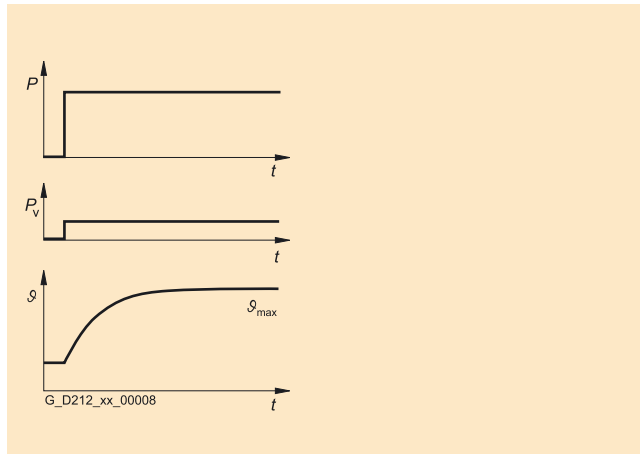

Figure 5-6 S1 duty (continuous operation)

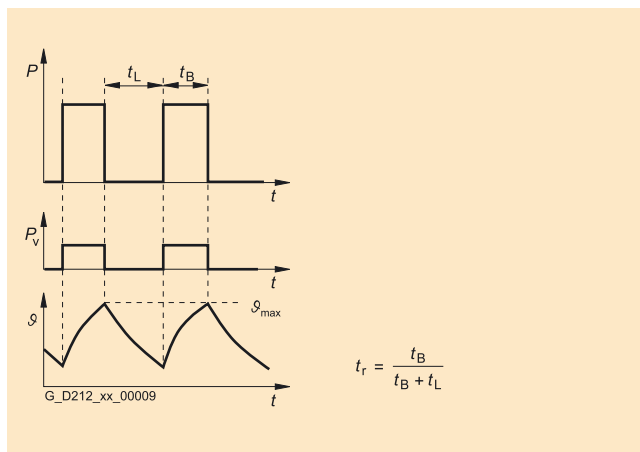

Figure 5-7 S3 duty (intermittent operation without influencing starting)

Fixed variables are usually used for the relative on period:

- S3 – 60%
- S3 – 40%
- S3 – 25%

The corresponding motor characteristics are provided for these specifications. The load torque must lie below the corresponding thermal limiting characteristic curve of the motor. An overload must be taken into consideration for load duty cycles with varying on periods.

Load cycle

A load duty cycle defines the characteristics of the motor speed and the torque with respect to time.

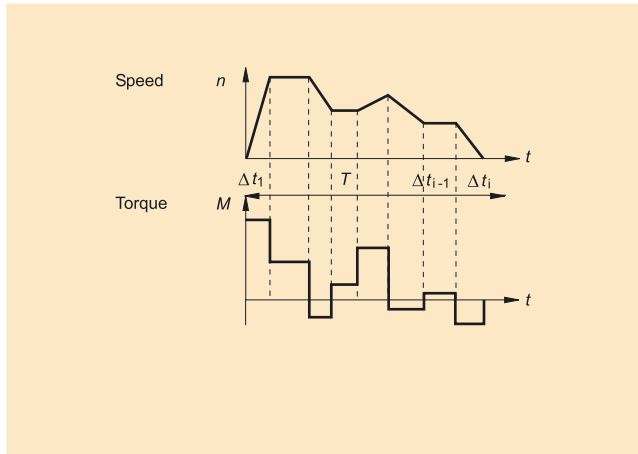

Figure 5-8 Example of a load duty cycle

A load torque is specified for each time period. In addition to the load torque, the average load moment of inertia and motor moment of inertia must be taken into account for acceleration. It may be necessary to take into account a frictional torque that opposes the direction of motion.

The gear ratio and gear efficiency must be taken into account when calculating the load and/or accelerating torque to be provided by the motor. A higher gear ratio increases positioning accuracy in terms of encoder resolution. For any given motor encoder resolution, as the gear ratio increases, so does the resolution of the machine position to be detected.

For the motor torque in a time slice Δt_i the following applies:

$$M_{Mot, i} = (J_M + J_G) \cdot \frac{2\pi}{60} \cdot \frac{\Delta n_{Last, i}}{\Delta t_i} \cdot i + (J_{Last} \cdot \frac{2\pi}{60} \cdot \frac{\Delta n_{Last, i}}{\Delta t_i} + M_{Last, i} + M_R) \cdot \frac{1}{i \cdot \eta_G}$$

The motor speed is:

$$n_{Mot, i} = n_{Last, i} \cdot i$$

The RMS torque is obtained as follows:

$$M_{Mot, eff} = \sqrt{\frac{\sum M_{Mot, i}^2 \cdot \Delta t_i}{T}}$$

The average motor speed is calculated as follows:

$$n_{Mot, mittel} = \frac{\sum \frac{n_{Mot, k, A} + n_{Mot, k, E}}{2} \cdot \Delta t_i}{t_e}$$

J_M	Motor moment of inertia
J_G	Gearbox moment of inertia
J_{load}	Load moment of inertia
n_{Load}	Load speed
i	Gear ratio
η_G	Gearbox efficiency
M_{load}	Load torque
M_R	Frictional torque
T	Cycle time, clock cycle time
A; E	Initial value, final value in time slice Δt_i
t_e	ON period
Δt_i	Time interval

The RMS torque M_{rms} must lie below the S1 curve.

The maximum torque M_{max} is produced during the acceleration operation.

For synchronous motors, M_{max} must lie below the voltage limiting characteristic curve.

For induction motors, M_{max} must lie below the stability limit.

In summary, the motor is selected as follows:

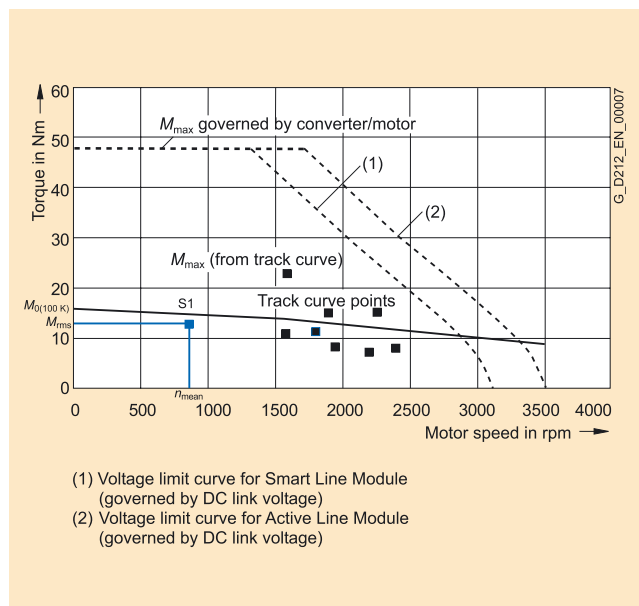

Figure 5-9 Selecting motors depending on the load duty cycle (example)

5.4.3 3. Specification of the motor

Through variation, it is now possible to identify a motor which meets the requirements of the application.

In a second step, a check is made as to whether the thermal limits are maintained. To do this, the motor current at the base load must be calculated. When configuring according to duty cycle with constant ON period with overload, the overload current must be calculated relative to the required overload torque.

The calculation depends on the type of motor used (synchronous motor, induction motor) and the particular application (duty cycle with constant ON period, free duty cycle).

Finally, the other motor features must be defined by configuring the motor options.

Motor components

6.1 Thermal motor protection

A temperature-dependent resistor is integrated as temperature sensor to monitor the motor temperature.

Table 6-1 Features and technical data

Type	KTY 84
Resistance when cold (20° C)	approx. 580 Ohm
Resistance when hot (100° C)	approx. 1000 Ohm
Connecting	via signal cable

The resistance of the KTY 84 thermistor changes proportionally to the winding temperature change.

The temperature signal is sensed and evaluated in the drive converter whose closed-loop control takes into account the temperature characteristic of the motor resistances.

When a fault occurs, an appropriate message is output at the drive converter. When the motor temperature increases, a message "Alarm motor overtemperature" is output; this must be externally evaluated. If this signal is not observed, the drive converter shuts down with the appropriate fault message when the motor limiting temperature or the shutdown temperature is exceeded.

 Warning
<p>If the user carries-out an additional high-voltage test, then the ends of the temperature sensor cables must be short-circuited before the test is carried-out!</p> <p>If the test voltage is connected to a temperature sensor terminal, then it will be destroyed.</p> <p>The polarity must be carefully observed.</p>

The temperature sensor is designed so that the DIN/EN requirement for "protective separation" is fulfilled.

 Caution
The integrated temperature sensor only protects the synchronous motors to a certain extent against overloads
Shaft height 48: up to $2 \cdot I_{0(60K)}$ and speed $\neq 0$
As of shaft height 63: up to $3 \cdot I_{0(60K)}$ and speed $\neq 0$
For load applications that are critical from a thermal perspective, e.g. overload when the motor is stationary or an overload of M_{max} longer than 4 s, adequate protection is no longer available.

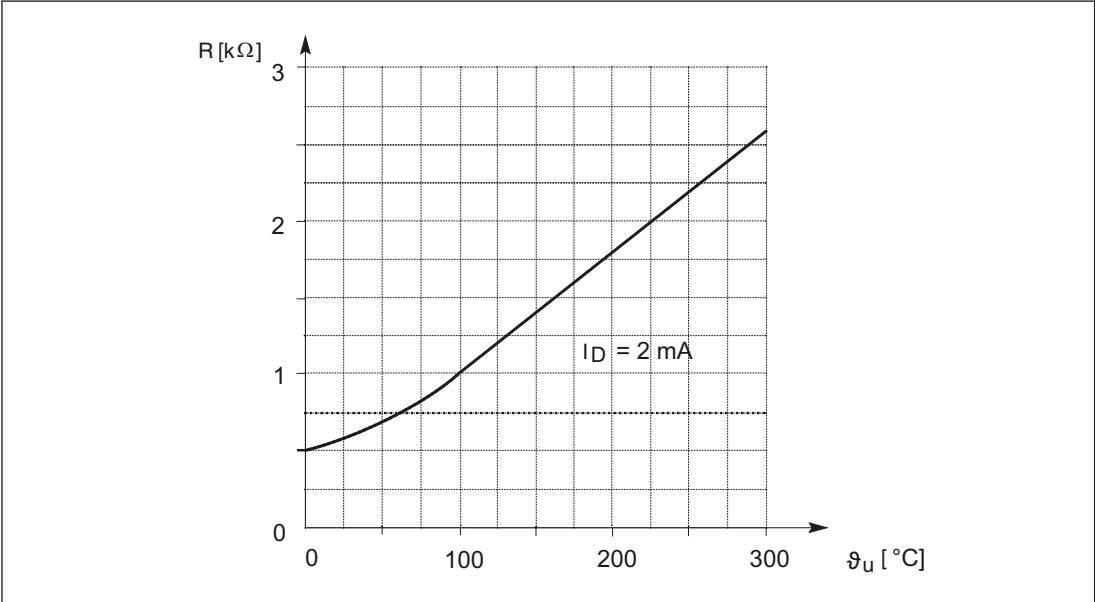

Figure 6-1 Resistance characteristic of the KTY 84 as a function of the temperature

6.2 Encoder (option)

6.2.1 Encoder overview

The encoder is selected in the motor Order No. (MLFB) using the appropriate letter at the 14th position.

Note

The letter ID at the 14th position of the Order No. (MLFB) differs for motors with and without DRIVE-CLiQ.

Table 6-2 Encoders for motors with and without DRIVE-CLiQ

Encoder type	Order number (MLFB)	
	With DRIVE-CLiQ	Without DRIVE-CLiQ
Incremental encoder 22 bit (I-22-DQ)	D	-
Incremental encoder sin/cos 1 Vpp (I-2048)	-	N
Absolute encoder 22 bit multiturn (AM-22-DQ)	F	-
Absolute encoder EnDat multiturn (AM-2048)	-	M

Notice

The encoders can be replaced without adjustment.
Referencing has to be performed again for absolute encoders.

6.2.2 Encoder connection for motors with DRIVE-CLiQ

Motors with DRIVE-CLiQ have a sensor module that includes the encoder evaluation, the motor temperature sensing and an electronic rating plate.

This sensor module instead of the signal connector and has a 10-pin RJ45-plus socket.

Warning

The sensor module contains motor and encoder-specific data as well as an electronic rating plate. This is the reason that this sensor module may only be operated on the original motor - and may not be mounted onto other motors or replaced by a sensor module from other motors.

The sensor module has direct contact to components that can be destroyed by electrostatic discharge (ESDS). Neither hands nor tools that could be electrostatically charged may come into contact with the connections.

6.2.3 Encoder connection for motors without DRIVE-CLiQ

Motors without DRIVE-CLiQ are connected using the 17-pin flange socket.

6.2.4 Incremental encoders

Function:

- Angular measuring system for the commutation
- Speed actual value sensing
- Indirect incremental measuring system for the position control loop
- One zero pulse (reference mark) per revolution

Table 6-3 Technical data for incremental encoders

Properties	Incremental encoder sin/cos 1 Vpp (I-2048)	Incremental encoder 22 bit (I-22-DQ)
Mech. limiting speed	12000 RPM	12000 RPM
Operating voltage	5 V ± 5 %	24 V
Current consumption	150 mA, maximum	180 mA, maximum
Resolution, incremental (periods per revolution)	2048 pulses/rev	22 bit
Incremental signals	1 Vpp	---
Angular error	± 40"	± 40"
Serial absolute position interface	---	DRIVE-CLiQ
C-D track (rotor position)	1 Vpp	---

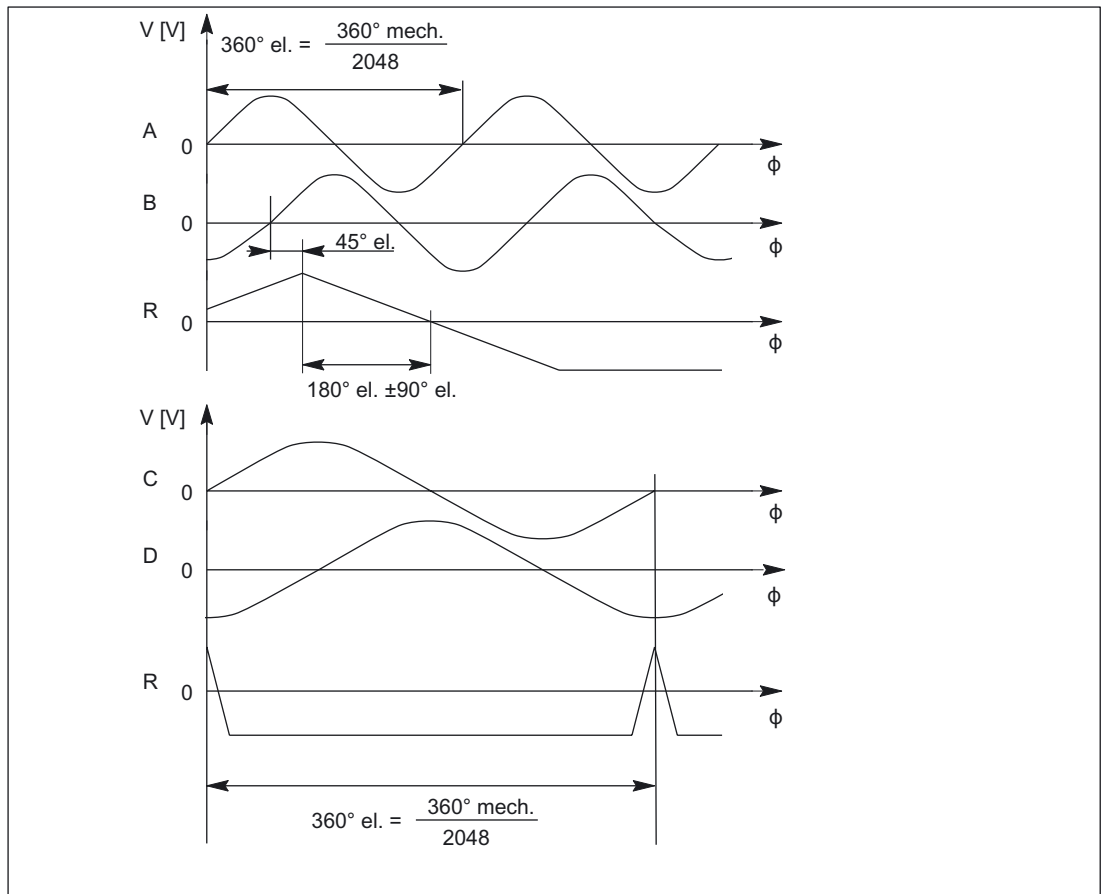

Figure 6-2 Signal sequence and assignment for a positive direction of rotation

6.2.5 Absolute encoder

Function:

- Angular measuring system for the commutation
- Speed actual value sensing
- Indirect absolute measuring system for the position control loop

Table 6-4 Technical data, absolute value encoder

Features	Absolute encoder EnDat multiturn (AM-2048)	Absolute encoder 22 bit multiturn (AM-22-DQ)
Mech. limiting speed	12000 RPM	12000 RPM
Operating voltage	5 V ± 5 %	24 V
Current consumption	300 mA, maximum	220 mA, maximum
Resolution, incremental (periods per revolution)	2048 pulses/rev	22 bit
Incremental signals	1 V _{pp}	---
Angular error	± 40"	± 40"
Serial absolute position interface	EnDat	DRIVE-CLiQ

6.3 Holding brake (option)

6.3.1 Properties

- The integrated or mounted holding brake is used to clamp the motor shaft when the motor is at a standstill. The holding brake is **not** a working brake that is used to brake a motor that is still rotating.
- Restricted Emergency Stop operation is permissible. Up to 2000 braking operations can be executed with 300% rotor moment of inertia as external moment of inertia from a speed of 3000 RPM without the brake being subject to an inadmissible amount of wear. The specific highest switching work for each emergency braking operation may not be exceeded.
- The rated voltage of the holding brake is 24 VDC.

 **Caution**

The rated voltage is 24 VDC +/- 10%. Voltages outside this tolerance bandwidth can result in faults.

Inadmissible wear means that the braking function can no longer be guaranteed! It is not permissible to exceed the above specified Emergency Stop conditions or to repeatedly briefly accelerate the motor against a holding brake that is still closed. This means that the switching times of the brakes and relays must be taken into account in the drive control and enable functions.

Notice

Motors with or without holding brake cannot be subsequently retrofitted!

Motors with holding brake are longer by the mounted space required (refer to the dimension drawings).

6.3.2 Permanent-magnet brake

Mode of operation of a permanent-magnet brake

The magnetic field of the permanent magnets results in a pulling force on the brake armature disk. This means that in the no-current condition, the brake is closed and the motor shaft is held.

When 24 VDC rated voltage is connected to the brake, the solenoid – through which current flows – establishes an opposing field. This neutralizes the force of the permanent magnets. Permanent magnet brakes have a proportionally stiff connection to the motor rotor. This is the reason that this brake is almost without any play.

Caution

Motors with integrated permanent-magnet holding brake cannot be subject to axial forces at the shaft end! This applies when installing the system and during operation.

6.3.3 Protective circuitry for the brake

Caution

In order to avoid overvoltages when shutting down and the possible negative impact on the plant or system environment, a protective circuit must be integrated into the brake feeder cable (refer to Fig. "Recommended circuit for the external power supply with protective circuit").

If protective circuitry is not used, voltage peaks over 1000 V can occur in the millisecond range. Brake solenoid, switching contacts and electronic components could be destroyed.

Sensitive electronic components (e.g. logic components) can even be damaged as a result of a lower switch-off voltage. The power limits (e.g. ratings) of the components used should be carefully observed.

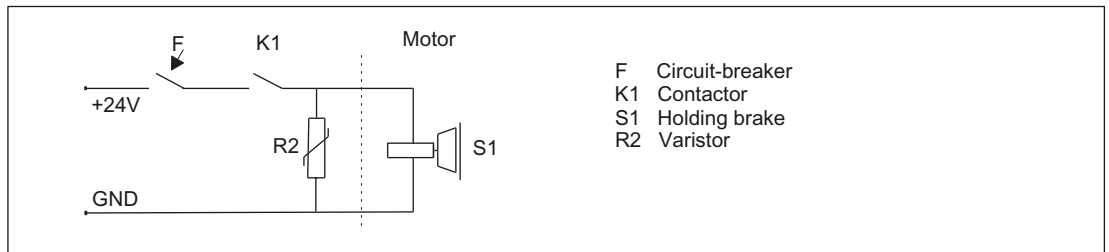

Figure 6-3 Recommended circuit for the external power supply with protective circuit

Table 6-5 Example Electronic components for the recommended circuit

Electr. component	Examples		
F	3RV10 circuit-breaker with current paths connected in series (if required with mounted auxiliary contact 3RV1901 to provide a feedback signal for the drive).	or	Miniature circuit-breaker 5SX21 (if required with mounted auxiliary contact to provide a feedback signal for the drive).
K1	Auxiliary contactor 3RH11	or	Contactor 3RT10
R2	Varistor SIOVS14K30 (EPCOS)		

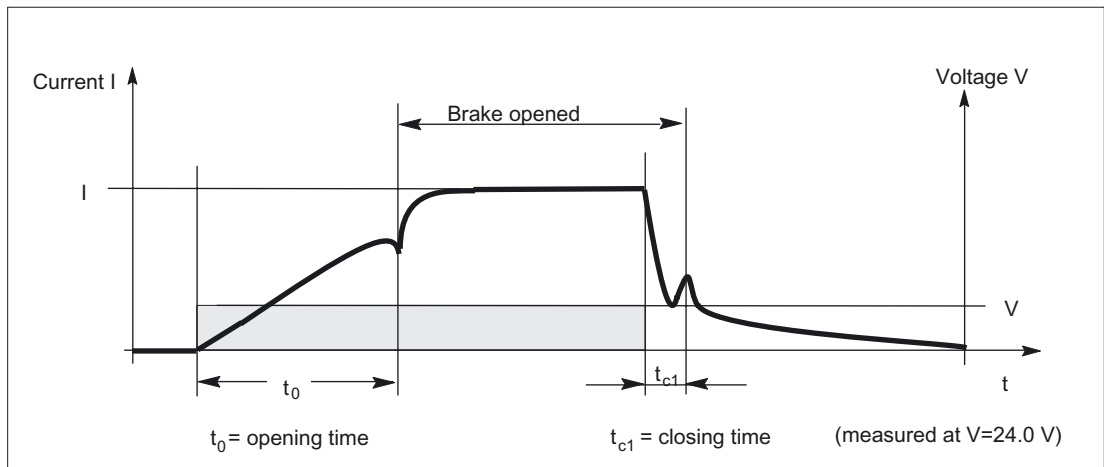

Figure 6-4 Terminology (time) for holding operation

Important information and instructions when installing the connecting cable

The brake connecting cable is included in the power cable. The insulation between the power and brake connection is dimensioned for basic insulation (VDE 600 V/1000 V UL). The relay K1, located between the coil and contact, must also have basic insulation in order to protect the internal logic voltage (PELV=Protective Extra Low Voltage). The PELV supply may not be used to supply the holding brake (refer to Fig. "Recommended circuit for the external power supply with protective circuit").

Determining the minimum voltage

The minimum voltage of 24 VDC -10% must be available at the connector on the motor side in order to guarantee that the brake reliably opens. If the maximum voltage of 24 VDC +10% is exceeded, then the brake could re-close. The voltage drop along the brake feeder cable must be taken into consideration.

The voltage drop ΔU for copper cables can be approximately calculated as follows:

$$\Delta U [V] = 0.042 \cdot (l/q) \cdot I_{\text{Brake}}$$

l = Cable length [m]
 q = Brake core cross section [mm²]
 I_{Brake} = DC current of brake [A]

6.3.4 Technical data of the holding brake

Table 6-6 Technical data of the holding brakes used for 1FT7 Compact motors

Motor type	Brake designation	Holding torque M_4 at 120° C	Min. braking torque M_1	DC current at 20° C	Opening time with with varistor	Closing time with varistor	Highest switching energy
		[Nm]	[Nm]	[A]	[ms]	[ms]	[J]
1FT704□	HT07P01	8	5	0,6	70	25	270
1FT706□	HT09P01	18	11	0,8	150	35	880
1FT708□	HT11P01	48	25	1,0	200	40	1900
1FT710□	HT14P01	85	35	1,6	250	50	5300

Holding torque M_4

The holding torque M_4 is the highest permissible torque with which the closed brake can be loaded in steady-state operation without slip (holding function when motor is stationary).

Dynamic braking torque M_1

The dynamic braking torque M_1 is the smallest mean dynamic braking torque that can occur in emergency stop operation.

Technical data and characteristic curves

7.1 Introduction

Note

The voltage limiting characteristics [a], [b], [c] refer to the converter output voltage as a function of the supply voltage.

Supply voltage / converter type:

400 V 3-phase AC / SINAMICS SLM
400 V 3-phase AC / SINAMICS ALM
480 V 3-phase AC / SINAMICS SLM

Note

The specified thermal S3 limiting characteristics are referred to $\Delta T = 100$ K for a 10 min. duty cycle.

7.2 Technical data and characteristic curves

Table 7-1 1FT7042-□AF7

Technical data	Code	Unit	Value		
Engineering data					
Rated speed	n_N	RPM	3000		
Number of poles	2p	---	6		
Rated torque (100K)	$M_{N(100K)}$	Nm	2,7		
Rated current	I_r	A	2,1		
Static torque (60 K)	$M_{0(60K)}$	Nm	2,5		
Static torque (100 K)	$M_{0(100K)}$	Nm	3		
Stall current (60 K)	$I_{0(60K)}$	A	1,7		
Stall current (100 K)	$I_{0(100K)}$	A	2,1		
Moment of inertia (with brake)	J_{MotBr}	10^{-4} kgm ²	3,68		
Moment of inertia (without brake)	J_{mot}	10^{-4} kgm ²	2,81		
Optimum operating point					
Optimum speed	n_{opt}	RPM	3000		
Optimum power	P_{opt}	kW	0,85		
Limiting data					
Max. permissible speed (mech.)	$n_{max\ mech.}$	RPM	9000		
Max. permissible speed (inverter)	$n_{max\ inv}$	RPM	6600		
Max. torque	M_{max}	Nm	13		
Maximum current	I_{max}	A	11		
Physical constants					
Torque constant	k_T	Nm/A	1,43		
Voltage constant	k_E	V/1000 RPM	87		
Winding resistance at 20° C	$R_{ph.}$	Ω	3,5		
Rotating field inductance	L_D	mH	21,4		
Electrical time constant	T_{el}	ms	6		
Mechanical time constant	T_{mech}	ms	1,4		
Thermal time constant	T_{th}	min	20		
Shaft torsional stiffness	C_t	Nm/rad	11700		
Weight with brake	m_{MotBr}	kg	5,5		
Weight without brake	m_{Mot}	kg	4,6		
Recommended Motor Module 6SL312□-□TE13-0AA□					
Rated inverter current	$I_{N\ Inv}$	A	3		
Maximum inverter current	$I_{max\ Inv}$	A	6		
Max. torque at $I_{max\ Inv}$	$M_{max\ Inv}$	Nm	8		

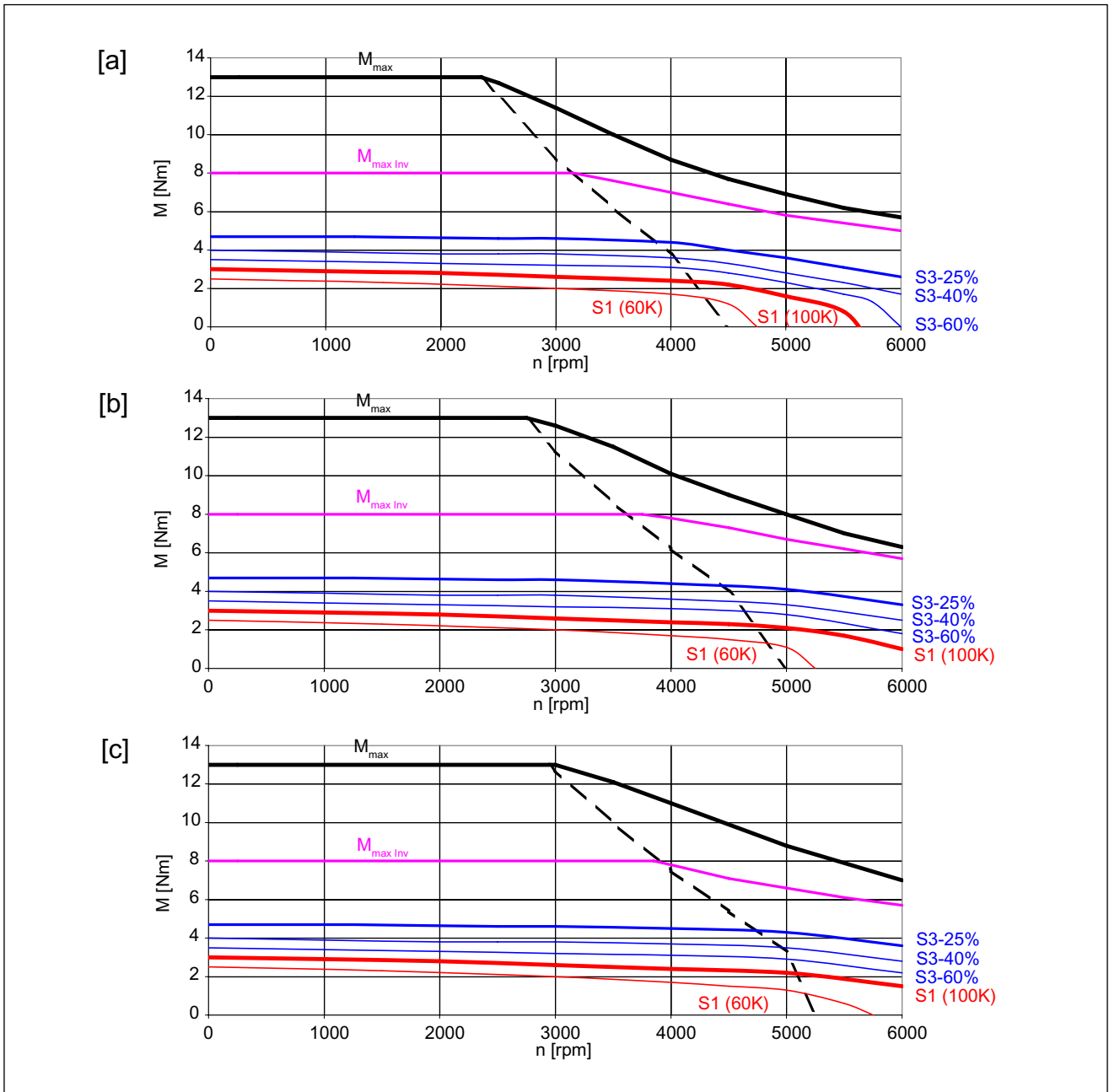

Figure 7-1 1FT7042-□AF7

- [a] SINAMICS SLM 400 V
- [b] SINAMICS ALM 400 V
- [c] SINAMICS SLM 480 V

The characteristic curves are only valid for optimized converter setting data

7.2 Technical data and characteristic curves

Table 7-2 1FT7042-□AK7

Technical data	Code	Unit	Value		
Engineering data					
Rated speed	n_N	RPM	6000		
Number of poles	2p	---	6		
Rated torque (100K)	$M_{N(100K)}$	Nm	2		
Rated current	I_r	A	3		
Static torque (60 K)	$M_{0(60K)}$	Nm	2,4		
Static torque (100 K)	$M_{0(100K)}$	Nm	3		
Stall current (60 K)	$I_{0(60K)}$	A	3,1		
Stall current (100 K)	$I_{0(100K)}$	A	3,9		
Moment of inertia (with brake)	J_{MotBr}	10^{-4} kgm ²	3,68		
Moment of inertia (without brake)	J_{mot}	10^{-4} kgm ²	2,81		
Optimum operating point					
Optimum speed	n_{opt}	RPM	6000		
Optimum power	P_{opt}	kW	1,26		
Limiting data					
Max. permissible speed (mech.)	$n_{max\ mech.}$	RPM	9000		
Max. permissible speed (inverter)	$n_{max\ inv}$	RPM	9000		
Max. torque	M_{max}	Nm	13		
Maximum current	I_{max}	A	21		
Physical constants					
Torque constant	k_T	Nm/A	0,77		
Voltage constant	k_E	V/1000 RPM	49		
Winding resistance at 20° C	$R_{ph.}$	Ω	1,12		
Rotating field inductance	L_D	mH	6,5		
Electrical time constant	T_{el}	ms	6		
Mechanical time constant	T_{mech}	ms	1,6		
Thermal time constant	T_{th}	min	20		
Shaft torsional stiffness	C_t	Nm/rad	11700		
Weight with brake	m_{MotBr}	kg	5,5		
Weight without brake	m_{Mot}	kg	4,6		
Recommended Motor Module 6SL312□-□TE15-0AA□					
Rated inverter current	$I_{N\ Inv}$	A	5		
Maximum inverter current	$I_{max\ Inv}$	A	10		
Max. torque at $I_{max\ Inv}$	$M_{max\ Inv}$	Nm	7		

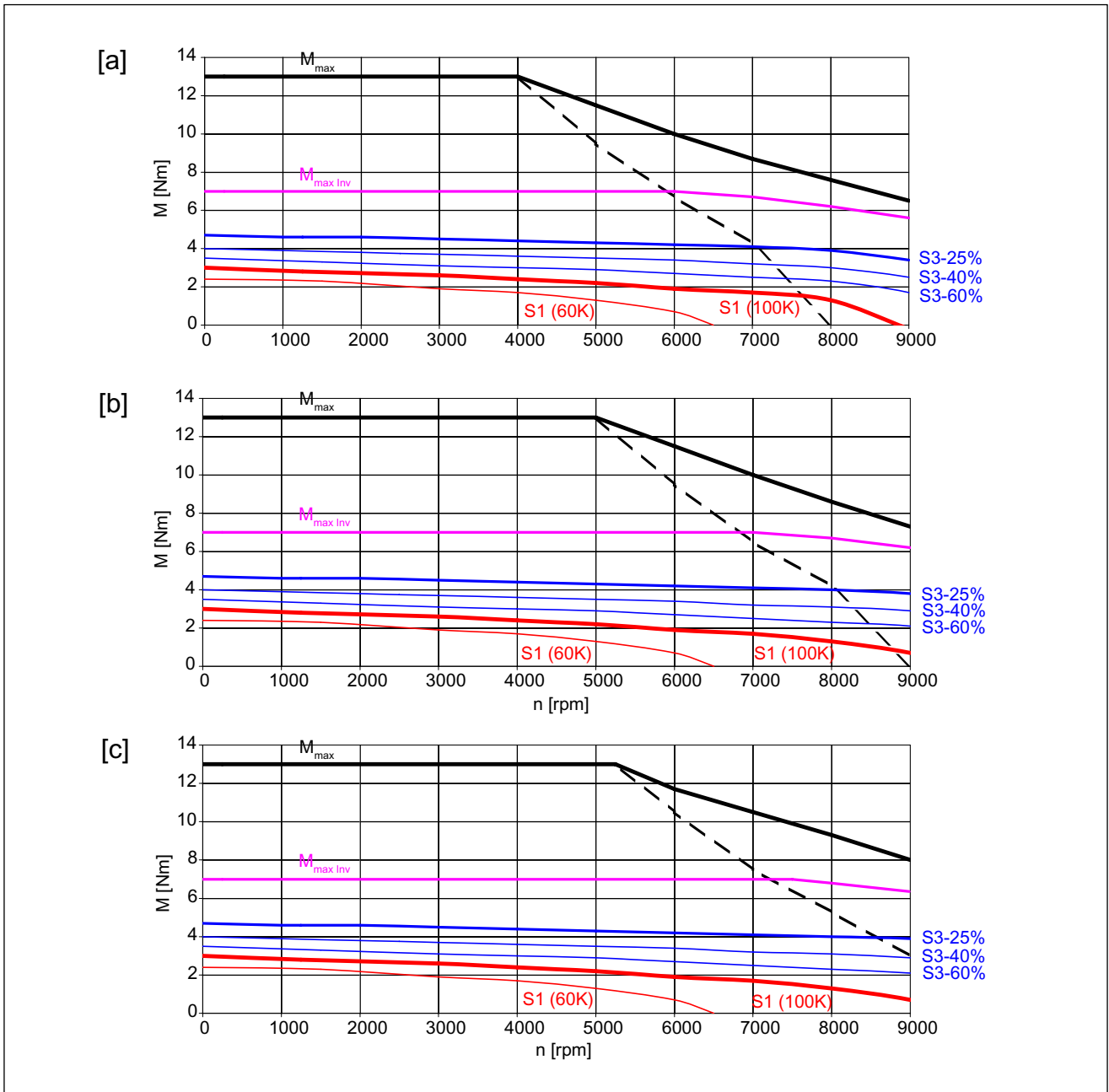

Figure 7-2 1FT7042-□AK7

- [a] SINAMICS SLM 400 V
- [b] SINAMICS ALM 400 V
- [c] SINAMICS SLM 480 V

The characteristic curves are only valid for optimized converter setting data

7.2 Technical data and characteristic curves

Table 7-3 1FT7044-□AF7

Technical data	Code	Unit	Value		
Engineering data					
Rated speed	n_N	RPM	3000		
Number of poles	2p	---	6		
Rated torque (100K)	$M_{N(100K)}$	Nm	4,3		
Rated current	I_r	A	2,6		
Static torque (60 K)	$M_{0(60K)}$	Nm	4,4		
Static torque (100 K)	$M_{0(100K)}$	Nm	5		
Stall current (60 K)	$I_{0(60K)}$	A	2,5		
Stall current (100 K)	$I_{0(100K)}$	A	2,8		
Moment of inertia (with brake)	J_{MotBr}	10^{-4} kgm ²	6,3		
Moment of inertia (without brake)	J_{mot}	10^{-4} kgm ²	5,43		
Optimum operating point					
Optimum speed	n_{opt}	RPM	3000		
Optimum power	P_{opt}	kW	1,35		
Limiting data					
Max. permissible speed (mech.)	$n_{max\ mech.}$	RPM	9000		
Max. permissible speed (inverter)	$n_{max\ inv}$	RPM	5200		
Max. torque	M_{max}	Nm	23		
Maximum current	I_{max}	A	16		
Physical constants					
Torque constant	k_T	Nm/A	1,79		
Voltage constant	k_E	V/1000 RPM	111		
Winding resistance at 20° C	$R_{ph.}$	Ω	2,3		
Rotating field inductance	L_D	mH	15		
Electrical time constant	T_{el}	ms	7		
Mechanical time constant	T_{mech}	ms	1,2		
Thermal time constant	T_{th}	min	35		
Shaft torsional stiffness	C_t	Nm/rad	9500		
Weight with brake	m_{MotBr}	kg	8,1		
Weight without brake	m_{Mot}	kg	7,2		
Recommended Motor Module 6SL312□-□TE13-0AA□					
Rated inverter current	$I_{N\ Inv}$	A	3		
Maximum inverter current	$I_{max\ Inv}$	A	6		
Max. torque at $I_{max\ Inv}$	$M_{max\ Inv}$	Nm	10		

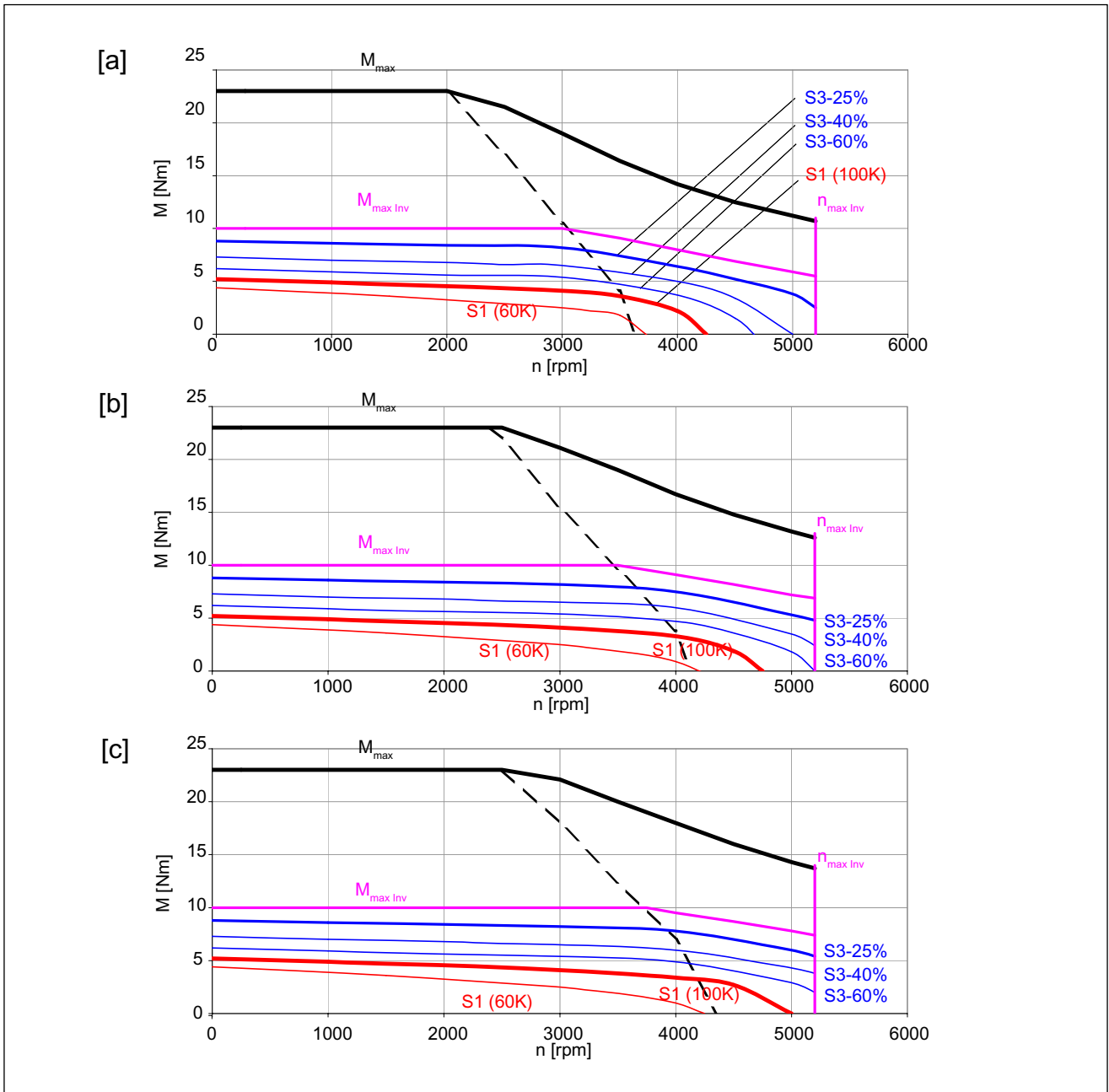

Figure 7-3 1FT7044-□AF7

- [a] SINAMICS SLM 400 V
- [b] SINAMICS ALM 400 V
- [c] SINAMICS SLM 480 V

The characteristic curves are only valid for optimized converter setting data

7.2 Technical data and characteristic curves

Table 7-4 1FT7044-□AK7

Technical data	Code	Unit	Value		
Engineering data					
Rated speed	n_N	RPM	6000		
Number of poles	2p	---	6		
Rated torque (100K)	$M_{N(100K)}$	Nm	2		
Rated current	I_r	A	2,5		
Static torque (60 K)	$M_{0(60K)}$	Nm	4,4		
Static torque (100 K)	$M_{0(100K)}$	Nm	5		
Stall current (60 K)	$I_{0(60K)}$	A	4,8		
Stall current (100 K)	$I_{0(100K)}$	A	5,7		
Moment of inertia (with brake)	J_{MotBr}	10^{-4} kgm ²	6,3		
Moment of inertia (without brake)	J_{mot}	10^{-4} kgm ²	5,43		
Optimum operating point					
Optimum speed	n_{opt}	RPM	4500		
Optimum power	P_{opt}	kW	1,41		
Limiting data					
Max. permissible speed (mech.)	$n_{max\ mech.}$	RPM	9000		
Max. permissible speed (inverter)	$n_{max\ inv}$	RPM	9000		
Max. torque	M_{max}	Nm	23		
Maximum current	I_{max}	A	30		
Physical constants					
Torque constant	k_T	Nm/A	0,88		
Voltage constant	k_E	V/1000 RPM	57		
Winding resistance at 20° C	$R_{ph.}$	Ω	0,61		
Rotating field inductance	L_D	mH	4,2		
Electrical time constant	T_{el}	ms	7		
Mechanical time constant	T_{mech}	ms	1,3		
Thermal time constant	T_{th}	min	35		
Shaft torsional stiffness	C_t	Nm/rad	9500		
Weight with brake	m_{MotBr}	kg	8,1		
Weight without brake	m_{Mot}	kg	7,2		
Recommended Motor Module 6SL312□-□TE21-0AA□					
Rated inverter current	$I_{N\ Inv}$	A	9		
Maximum inverter current	$I_{max\ Inv}$	A	18		
Max. torque at $I_{max\ Inv}$	$M_{max\ Inv}$	Nm	15		

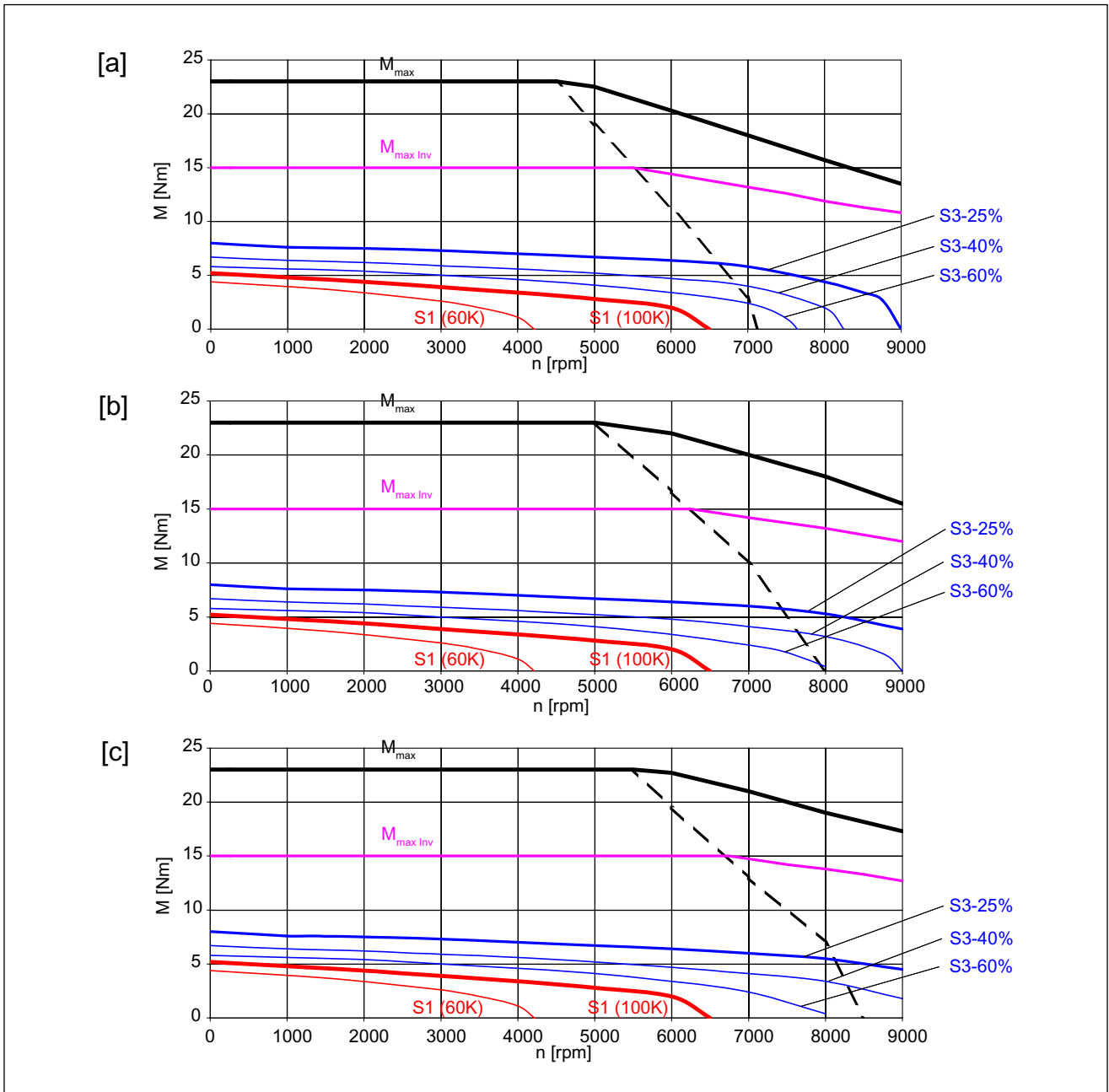

Figure 7-4 1FT7044-□AK7

- [a] SINAMICS SLM 400 V
- [b] SINAMICS ALM 400 V
- [c] SINAMICS SLM 480 V

The characteristic curves are only valid for optimized converter setting data

7.2 Technical data and characteristic curves

Table 7-5 1FT7046-□AF7

Technical data	Code	Unit	Value		
Engineering data					
Rated speed	n_N	RPM	3000		
Number of poles	2p	---	6		
Rated torque (100K)	$M_{N(100K)}$	Nm	5,6		
Rated current	I_r	A	3,5		
Static torque (60 K)	$M_{0(60K)}$	Nm	6		
Static torque (100 K)	$M_{0(100K)}$	Nm	7		
Stall current (60 K)	$I_{0(60K)}$	A	3,3		
Stall current (100 K)	$I_{0(100K)}$	A	4		
Moment of inertia (with brake)	J_{MotBr}	10^{-4} kgm ²	8,39		
Moment of inertia (without brake)	J_{mot}	10^{-4} kgm ²	7,52		
Optimum operating point					
Optimum speed	n_{opt}	RPM	3000		
Optimum power	P_{opt}	kW	1,76		
Limiting data					
Max. permissible speed (mech.)	$n_{max\ mech.}$	RPM	9000		
Max. permissible speed (inverter)	$n_{max\ inv}$	RPM	5200		
Max. torque	M_{max}	Nm	31		
Maximum current	I_{max}	A	19		
Physical constants					
Torque constant	k_T	Nm/A	1,75		
Voltage constant	k_E	V/1000 RPM	111		
Winding resistance at 20° C	$R_{ph.}$	Ω	1,55		
Rotating field inductance	L_D	mH	11		
Electrical time constant	T_{el}	ms	7		
Mechanical time constant	T_{mech}	ms	1,1		
Thermal time constant	T_{th}	min	35		
Shaft torsional stiffness	C_t	Nm/rad	8200		
Weight with brake	m_{MotBr}	kg	10,2		
Weight without brake	m_{Mot}	kg	9,3		
Recommended Motor Module 6SL312□-□TE15-0AA□					
Rated inverter current	$I_{N\ Inv}$	A	5		
Maximum inverter current	$I_{max\ Inv}$	A	10		
Max. torque at $I_{max\ Inv}$	$M_{max\ Inv}$	Nm	16,5		

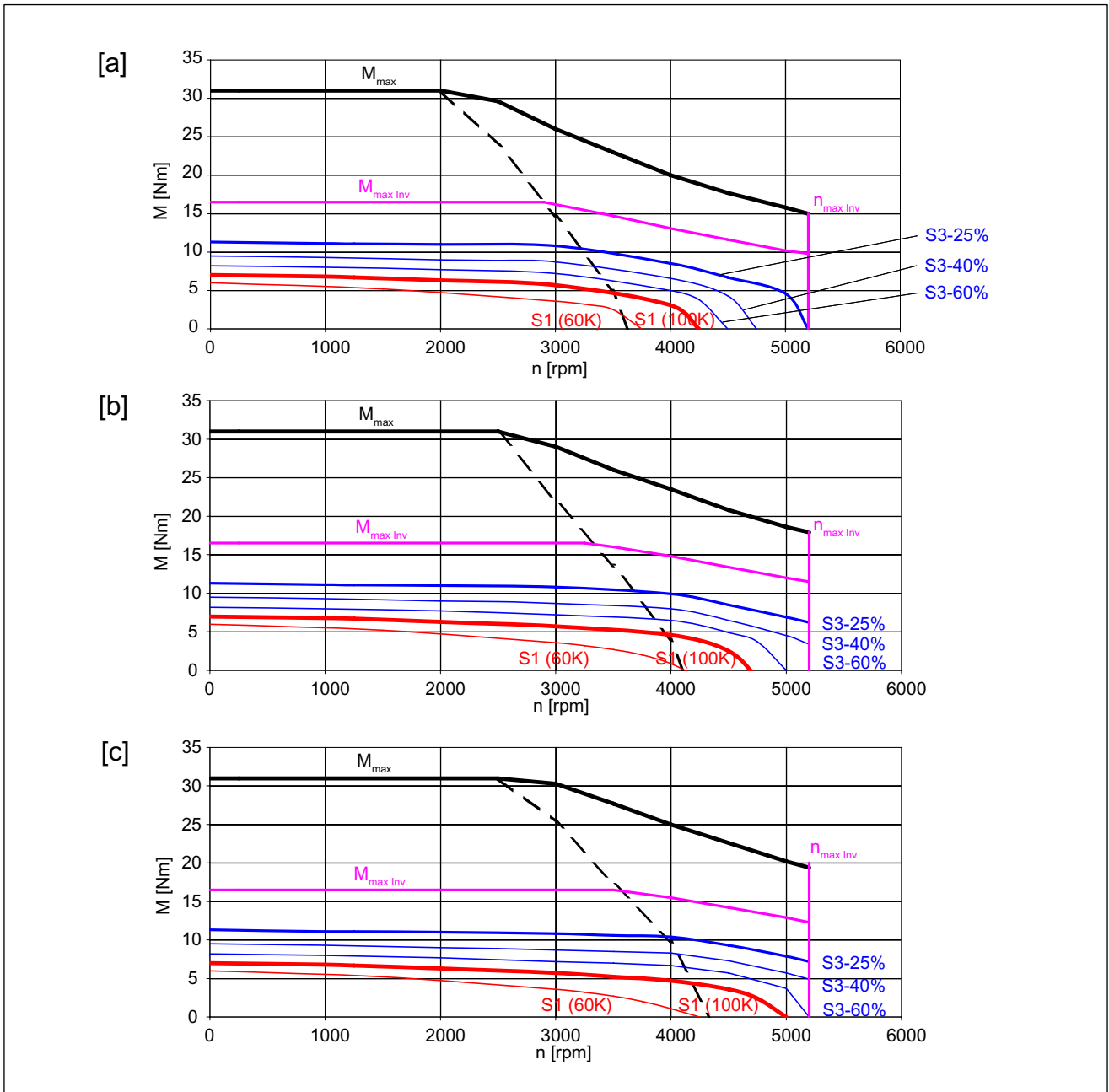

Figure 7-5 1FT7046-□AF7

- [a] SINAMICS SLM 400 V
- [b] SINAMICS ALM 400 V
- [c] SINAMICS SLM 480 V

The characteristic curves are only valid for optimized converter setting data

7.2 Technical data and characteristic curves

Table 7-6 1FT7046-□AH7

Technical data	Code	Unit	Value		
Engineering data					
Rated speed	n_N	RPM	4500		
Number of poles	2p	---	6		
Rated torque (100K)	$M_{N(100K)}$	Nm	2,4		
Rated current	I_r	A	3,2		
Static torque (60 K)	$M_{0(60K)}$	Nm	6		
Static torque (100 K)	$M_{0(100K)}$	Nm	7		
Stall current (60 K)	$I_{0(60K)}$	A	6,7		
Stall current (100 K)	$I_{0(100K)}$	A	8,1		
Moment of inertia (with brake)	J_{MotBr}	10^{-4} kgm ²	8,39		
Moment of inertia (without brake)	J_{mot}	10^{-4} kgm ²	7,52		
Optimum operating point					
Optimum speed	n_{opt}	RPM	3500		
Optimum power	P_{opt}	kW	1,32		
Limiting data					
Max. permissible speed (mech.)	$n_{max\ mech.}$	RPM	9000		
Max. permissible speed (inverter)	$n_{max\ inv}$	RPM	9000		
Max. torque	M_{max}	Nm	31		
Maximum current	I_{max}	A	38		
Physical constants					
Torque constant	k_T	Nm/A	0,86		
Voltage constant	k_E	V/1000 RPM	57		
Winding resistance at 20° C	$R_{ph.}$	Ω	0,42		
Rotating field inductance	L_D	mH	2,9		
Electrical time constant	T_{el}	ms	7		
Mechanical time constant	T_{mech}	ms	1,3		
Thermal time constant	T_{th}	min	35		
Shaft torsional stiffness	C_t	Nm/rad	8200		
Weight with brake	m_{MotBr}	kg	10,2		
Weight without brake	m_{Mot}	kg	9,3		
Recommended Motor Module 6SL312□-□TE21-0AA□					
Rated inverter current	$I_{N\ Inv}$	A	9		
Maximum inverter current	$I_{max\ Inv}$	A	18		
Max. torque at $I_{max\ Inv}$	$M_{max\ Inv}$	Nm	15		

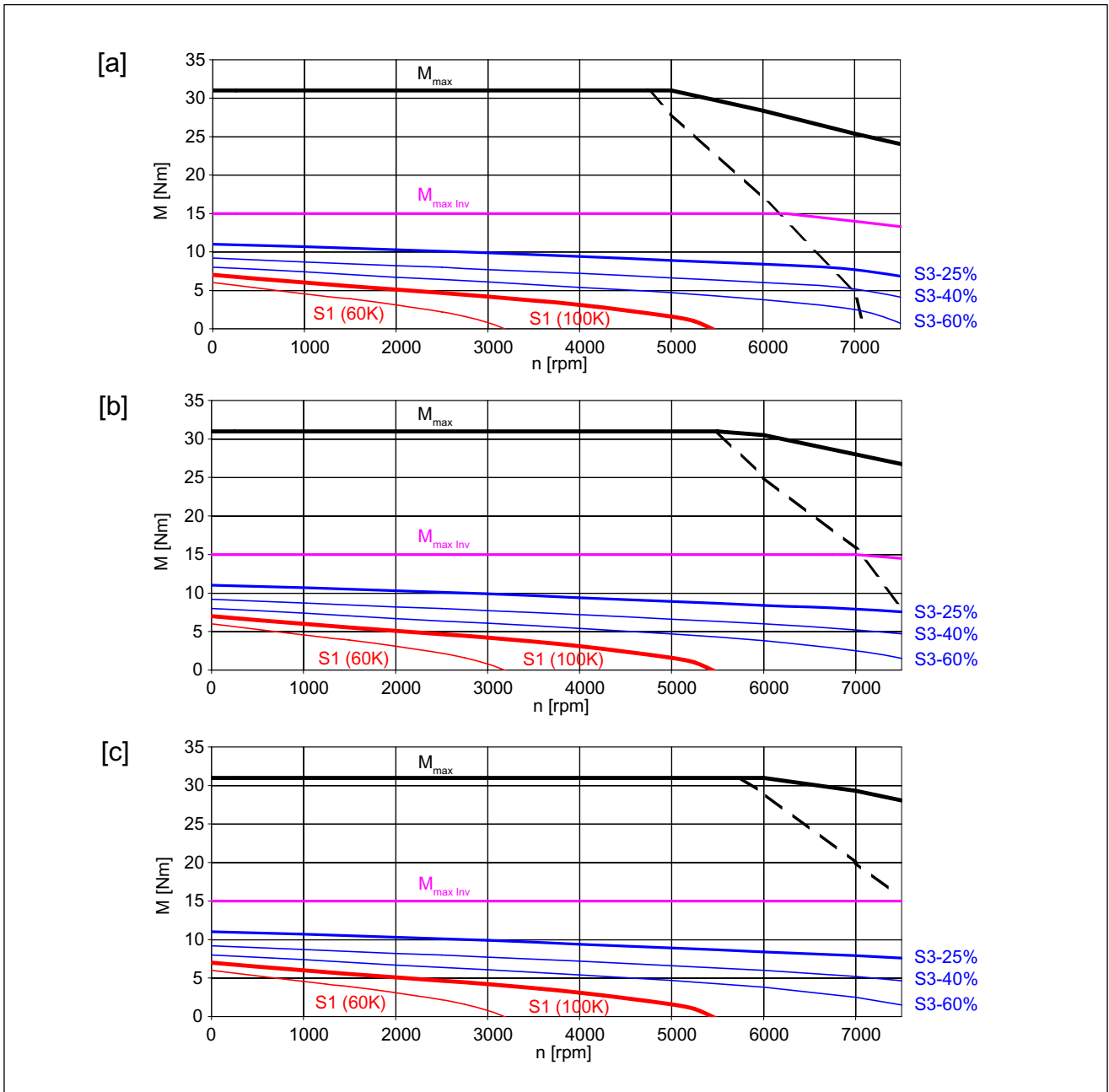

Figure 7-6 1FT7046-□AH7

- [a] SINAMICS SLM 400 V
- [b] SINAMICS ALM 400 V
- [c] SINAMICS SLM 480 V

The characteristic curves are only valid for optimized converter setting data

Technical data and characteristic curves

7.2 Technical data and characteristic curves

Table 7-7 1FT7062-□AF7

Technical data	Code	Unit	Value		
Engineering data					
Rated speed	n_N	RPM	3000		
Number of poles	$2p$	---	10		
Rated torque (100K)	$M_{N(100K)}$	Nm	5,4		
Rated current	I_r	A	3,9		
Static torque (60 K)	$M_{0(60K)}$	Nm	5		
Static torque (100 K)	$M_{0(100K)}$	Nm	6		
Stall current (60 K)	$I_{0(60K)}$	A	3,2		
Stall current (100 K)	$I_{0(100K)}$	A	3,9		
Moment of inertia (with brake)	J_{MotBr}	10^{-4} kgm ²	10,2		
Moment of inertia (without brake)	J_{mot}	10^{-4} kgm ²	7,36		
Optimum operating point					
Optimum speed	n_{opt}	RPM	3000		
Optimum power	P_{opt}	kW	1,70		
Limiting data					
Max. permissible speed (mech.)	$n_{max\ mech.}$	RPM	9000		
Max. permissible speed (inverter)	$n_{max\ inv}$	RPM	6100		
Max. torque	M_{max}	Nm	24		
Maximum current	I_{max}	A	22		
Physical constants					
Torque constant	k_T	Nm/A	1,54		
Voltage constant	k_E	V/1000 RPM	95		
Winding resistance at 20° C	$R_{ph.}$	Ω	1,57		
Rotating field inductance	L_D	mH	15,2		
Electrical time constant	T_{el}	ms	10		
Mechanical time constant	T_{mech}	ms	1,5		
Thermal time constant	T_{th}	min	25		
Shaft torsional stiffness	C_t	Nm/rad	28000		
Weight with brake	m_{MotBr}	kg	8,8		
Weight without brake	m_{Mot}	kg	7,1		
Recommended Motor Module 6SL312□-□TE15-0AA□					
Rated inverter current	$I_{N\ Inv}$	A	5		
Maximum inverter current	$I_{max\ Inv}$	A	10		
Max. torque at $I_{max\ Inv}$	$M_{max\ Inv}$	Nm	13		

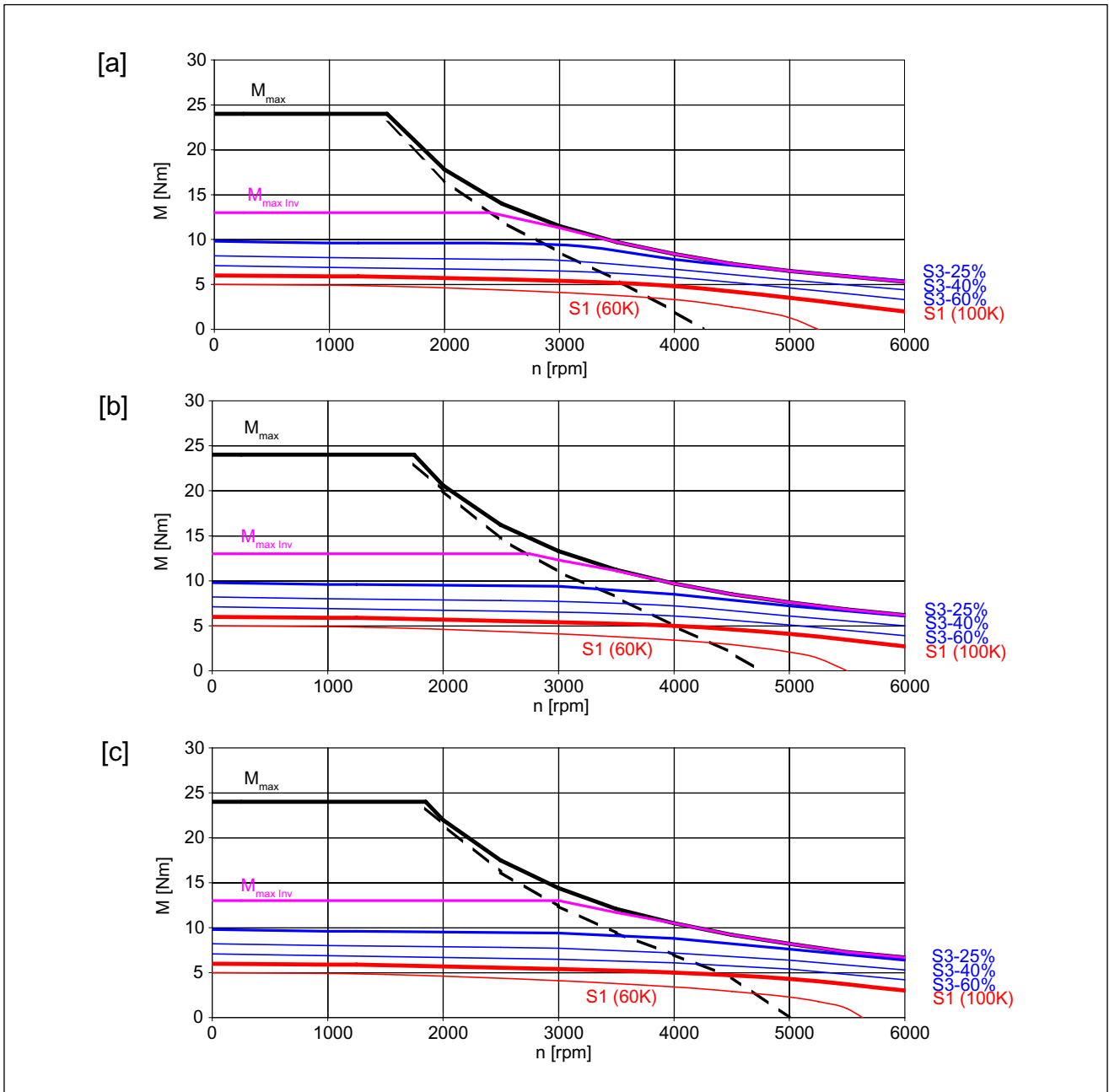

Figure 7-7 1FT7062-□AF7

- [a] SINAMICS SLM 400 V
- [b] SINAMICS ALM 400 V
- [c] SINAMICS SLM 480 V

The characteristic curves are only valid for optimized converter setting data

7.2 Technical data and characteristic curves

Table 7-8 1FT7062-□AK7

Technical data	Code	Unit	Value		
Engineering data					
Rated speed	n_N	RPM	6000		
Number of poles	2p	---	10		
Rated torque (100K)	$M_{N(100K)}$	Nm	3,3		
Rated current	I_r	A	5,4		
Static torque (60 K)	$M_{0(60K)}$	Nm	5		
Static torque (100 K)	$M_{0(100K)}$	Nm	6		
Stall current (60 K)	$I_{0(60K)}$	A	6,9		
Stall current (100 K)	$I_{0(100K)}$	A	8,4		
Moment of inertia (with brake)	J_{MotBr}	10^{-4} kgm ²	10,2		
Moment of inertia (without brake)	J_{mot}	10^{-4} kgm ²	7,36		
Optimum operating point					
Optimum speed	n_{opt}	RPM	5500		
Optimum power	P_{opt}	kW	2,13		
Limiting data					
Max. permissible speed (mech.)	$n_{max\ mech.}$	RPM	9000		
Max. permissible speed (inverter)	$n_{max\ inv}$	RPM	8000		
Max. torque	M_{max}	Nm	24		
Maximum current	I_{max}	A	47		
Physical constants					
Torque constant	k_T	Nm/A	0,71		
Voltage constant	k_E	V/1000 RPM	45		
Winding resistance at 20° C	$R_{ph.}$	Ω	0,34		
Rotating field inductance	L_D	mH	3,4		
Electrical time constant	T_{el}	ms	10		
Mechanical time constant	T_{mech}	ms	1,5		
Thermal time constant	T_{th}	min	25		
Shaft torsional stiffness	C_t	Nm/rad	28000		
Weight with brake	m_{MotBr}	kg	8,8		
Weight without brake	m_{Mot}	kg	7,1		
Recommended Motor Module 6SL312□-□TE21-0AA□					
Rated inverter current	$I_{N\ Inv}$	A	9		
Maximum inverter current	$I_{max\ Inv}$	A	18		
Max. torque at $I_{max\ Inv}$	$M_{max\ Inv}$	Nm	12		

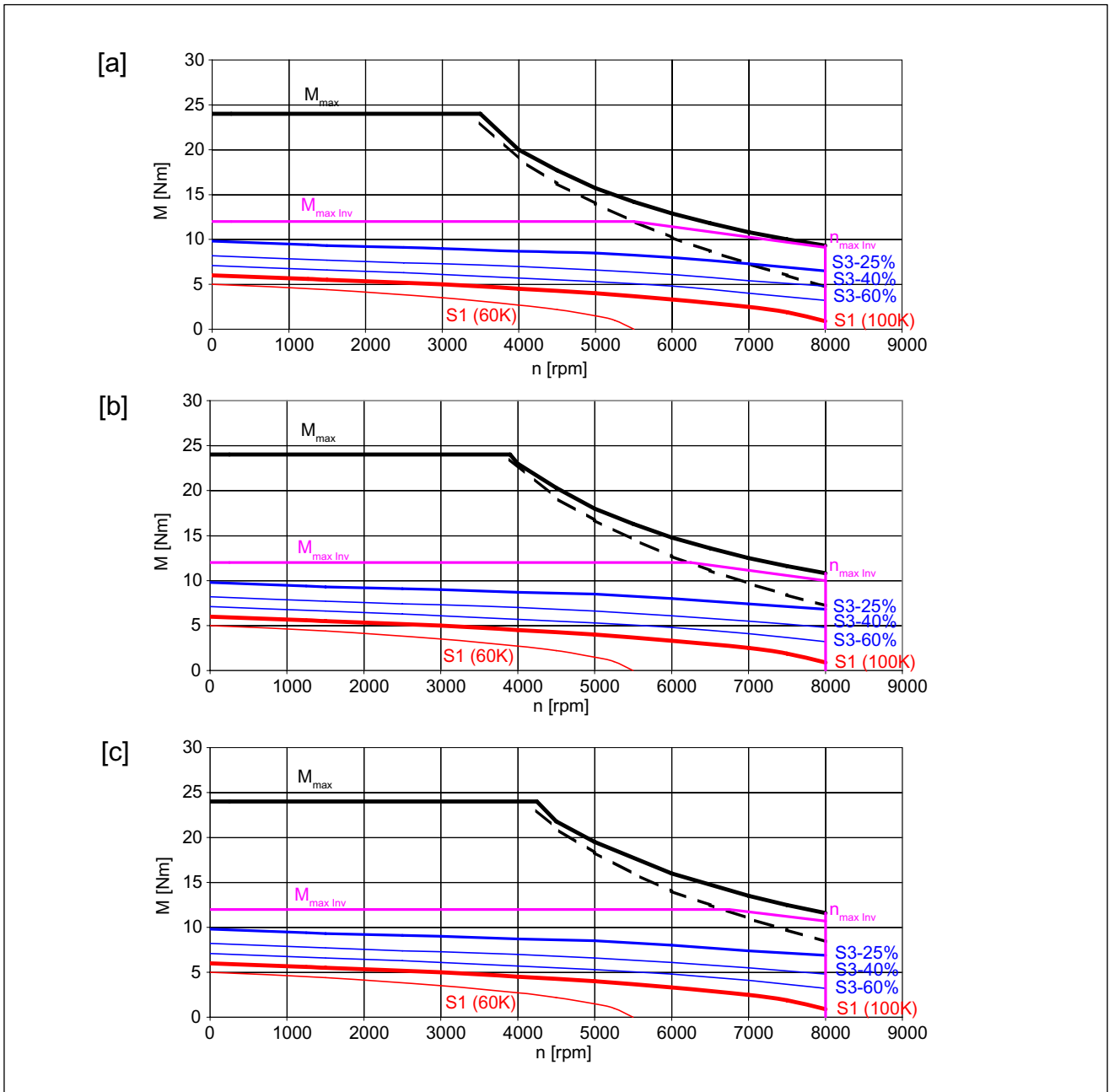

Figure 7-8 1FT7062-□AK7

- [a] SINAMICS SLM 400 V
- [b] SINAMICS ALM 400 V
- [c] SINAMICS SLM 480 V

The characteristic curves are only valid for optimized converter setting data

7.2 Technical data and characteristic curves

Table 7-9 1FT7064-□AF7

Technical data	Code	Unit	Value		
Engineering data					
Rated speed	n_N	RPM	3000		
Number of poles	2p	---	10		
Rated torque (100K)	$M_{N(100K)}$	Nm	7,6		
Rated current	I_r	A	5,2		
Static torque (60 K)	$M_{0(60K)}$	Nm	7,7		
Static torque (100 K)	$M_{0(100K)}$	Nm	9		
Stall current (60 K)	$I_{0(60K)}$	A	4,7		
Stall current (100 K)	$I_{0(100K)}$	A	5,7		
Moment of inertia (with brake)	J_{MotBr}	10^{-4} kgm ²	14,7		
Moment of inertia (without brake)	J_{mot}	10^{-4} kgm ²	11,9		
Optimum operating point					
Optimum speed	n_{opt}	RPM	3000		
Optimum power	P_{opt}	kW	2,39		
Limiting data					
Max. permissible speed (mech.)	$n_{max\ mech.}$	RPM	9000		
Max. permissible speed (inverter)	$n_{max\ inv}$	RPM	5700		
Max. torque	M_{max}	Nm	36		
Maximum current	I_{max}	A	29		
Physical constants					
Torque constant	k_T	Nm/A	1,58		
Voltage constant	k_E	V/1000 RPM	100		
Winding resistance at 20° C	$R_{ph.}$	Ω	0,9		
Rotating field inductance	L_D	mH	10		
Electrical time constant	T_{el}	ms	11		
Mechanical time constant	T_{mech}	ms	1,3		
Thermal time constant	T_{th}	min	30		
Shaft torsional stiffness	C_t	Nm/rad	26000		
Weight with brake	m_{MotBr}	kg	11,4		
Weight without brake	m_{Mot}	kg	9,7		
Recommended Motor Module 6SL312□-□TE21-0AA□					
Rated inverter current	$I_{N\ Inv}$	A	9		
Maximum inverter current	$I_{max\ Inv}$	A	18		
Max. torque at $I_{max\ Inv}$	$M_{max\ Inv}$	Nm	26		

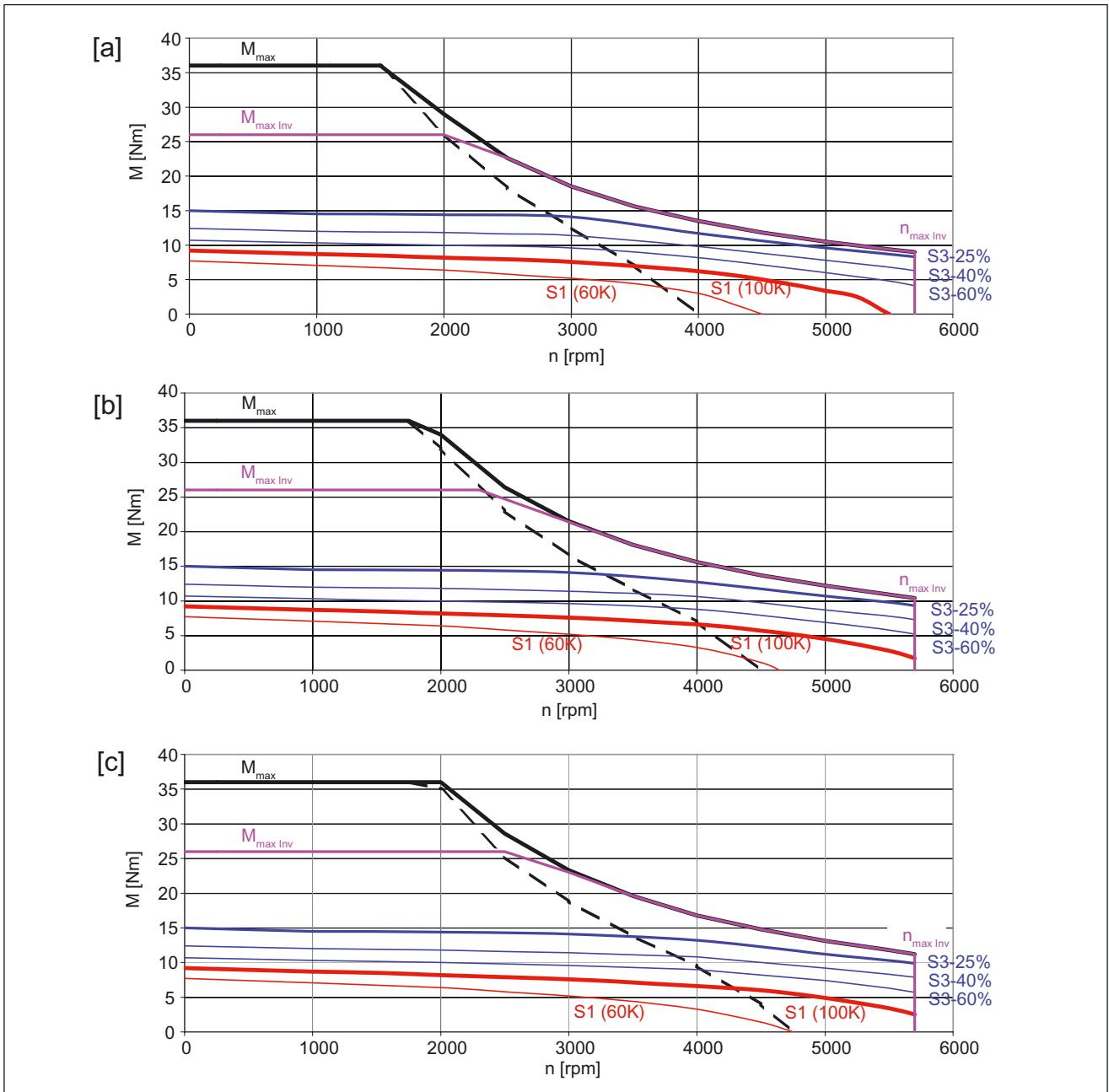

Figure 7-9 1FT7064-□AF7

- [a] SINAMICS SLM 400 V
- [b] SINAMICS ALM 400 V
- [c] SINAMICS SLM 480 V

The characteristic curves are only valid for optimized converter setting data

7.2 Technical data and characteristic curves

Table 7-10 1FT7064-□AK7

Technical data	Code	Unit	Value		
Engineering data					
Rated speed	n_N	RPM	6000		
Number of poles	2p	---	10		
Rated torque (100K)	$M_{N(100K)}$	Nm	2,9		
Rated current	I_r	A	3,4		
Static torque (60 K)	$M_{0(60K)}$	Nm	7,7		
Static torque (100 K)	$M_{0(100K)}$	Nm	9		
Stall current (60 K)	$I_{0(60K)}$	A	7,4		
Stall current (100 K)	$I_{0(100K)}$	A	9		
Moment of inertia (with brake)	J_{MotBr}	10^{-4} kgm ²	14,7		
Moment of inertia (without brake)	J_{mot}	10^{-4} kgm ²	11,9		
Optimum operating point					
Optimum speed	n_{opt}	RPM	4500		
Optimum power	P_{opt}	kW	2,59		
Limiting data					
Max. permissible speed (mech.)	$n_{max\ mech.}$	RPM	9000		
Max. permissible speed (inverter)	$n_{max\ inv}$	RPM	8000		
Max. torque	M_{max}	Nm	36		
Maximum current	I_{max}	A	45		
Physical constants					
Torque constant	k_T	Nm/A	1,00		
Voltage constant	k_E	V/1000 RPM	64		
Winding resistance at 20° C	$R_{ph.}$	Ω	0,38		
Rotating field inductance	L_D	mH	4,1		
Electrical time constant	T_{el}	ms	11		
Mechanical time constant	T_{mech}	ms	1,4		
Thermal time constant	T_{th}	min	30		
Shaft torsional stiffness	C_t	Nm/rad	26000		
Weight with brake	m_{MotBr}	kg	11,4		
Weight without brake	m_{Mot}	kg	9,7		
Recommended Motor Module 6SL312□-□TE21-0AA□					
Rated inverter current	$I_{N\ Inv}$	A	9		
Maximum inverter current	$I_{max\ Inv}$	A	18		
Max. torque at $I_{max\ Inv}$	$M_{max\ Inv}$	Nm	17		

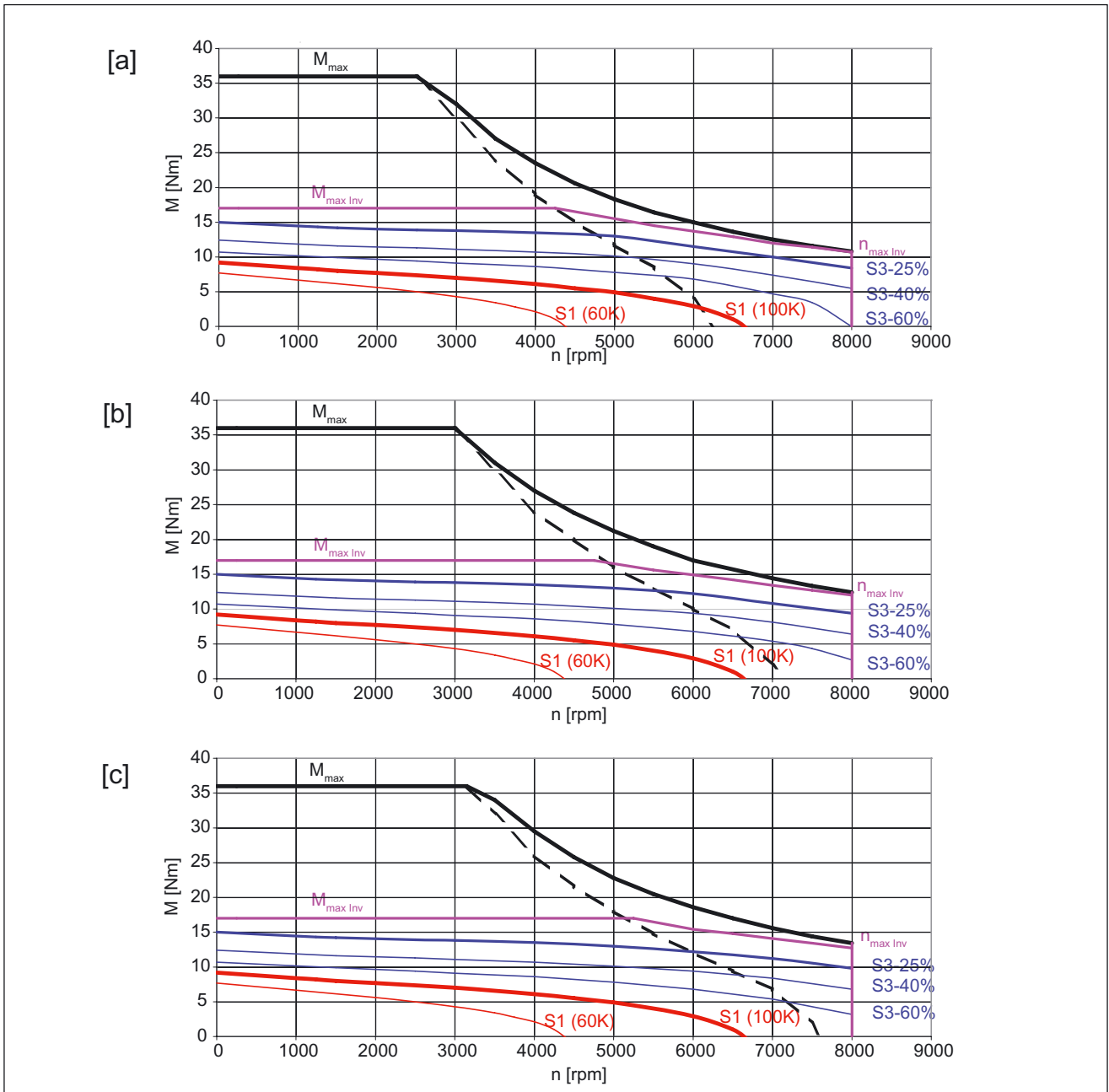

Figure 7-10 1FT7064-□AK7

- [a] SINAMICS SLM 400 V
- [b] SINAMICS ALM 400 V
- [c] SINAMICS SLM 480 V

The characteristic curves are only valid for optimized converter setting data

7.2 Technical data and characteristic curves

Table 7-11 1FT7066-□AF7

Technical data	Code	Unit	Value		
Engineering data					
Rated speed	n_N	RPM	3000		
Number of poles	2p	---	10		
Rated torque (100K)	$M_{N(100K)}$	Nm	9,3		
Rated current	I_r	A	7,2		
Static torque (60 K)	$M_{0(60K)}$	Nm	10		
Static torque (100 K)	$M_{0(100K)}$	Nm	12		
Stall current (60 K)	$I_{0(60K)}$	A	7		
Stall current (100 K)	$I_{0(100K)}$	A	8,4		
Moment of inertia (with brake)	J_{MotBr}	10^{-4} kgm ²	19,3		
Moment of inertia (without brake)	J_{mot}	10^{-4} kgm ²	16,4		
Optimum operating point					
Optimum speed	n_{opt}	RPM	3000		
Optimum power	P_{opt}	kW	2,92		
Limiting data					
Max. permissible speed (mech.)	$n_{max\ mech.}$	RPM	9000		
Max. permissible speed (inverter)	$n_{max\ inv}$	RPM	6500		
Max. torque	M_{max}	Nm	49		
Maximum current	I_{max}	A	44		
Physical constants					
Torque constant	k_T	Nm/A	1,43		
Voltage constant	k_E	V/1000 RPM	89,5		
Winding resistance at 20° C	$R_{ph.}$	Ω	0,49		
Rotating field inductance	L_D	mH	5,5		
Electrical time constant	T_{el}	ms	11		
Mechanical time constant	T_{mech}	ms	1,2		
Thermal time constant	T_{th}	min	40		
Shaft torsional stiffness	C_t	Nm/rad	24000		
Weight with brake	m_{MotBr}	kg	14,1		
Weight without brake	m_{Mot}	kg	12,3		
Recommended Motor Module 6SL312□-□TE21-0AA□					
Rated inverter current	$I_{N\ Inv}$	A	9		
Maximum inverter current	$I_{max\ Inv}$	A	18		
Max. torque at $I_{max\ Inv}$	$M_{max\ Inv}$	Nm	24		

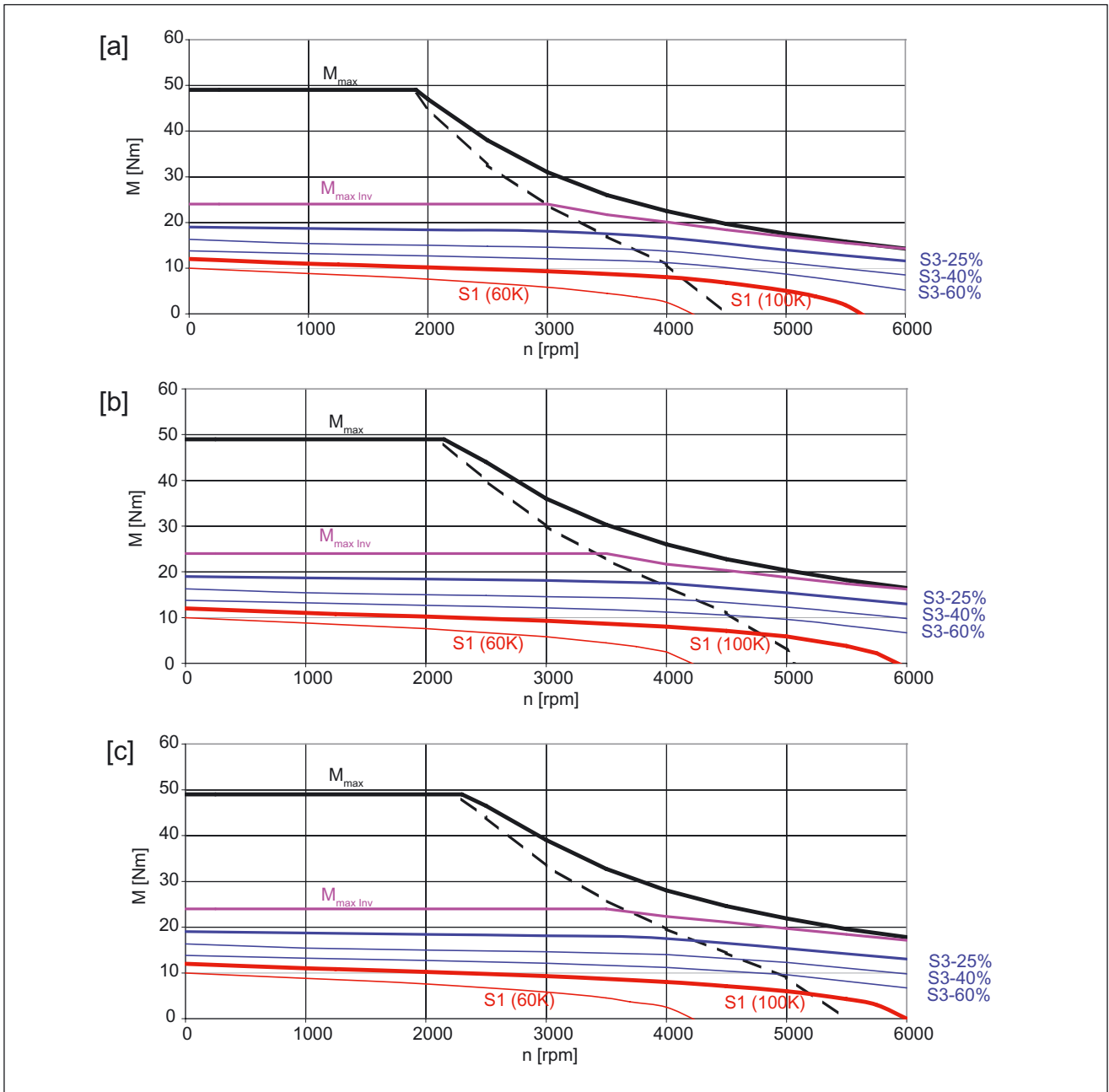

Figure 7-11 1FT7066-□AF7

- [a] SINAMICS SLM 400 V
- [b] SINAMICS ALM 400 V
- [c] SINAMICS SLM 480 V

The characteristic curves are only valid for optimized converter setting data

7.2 Technical data and characteristic curves

Table 7-12 1FT7066-□AH7

Technical data	Code	Unit	Value		
Engineering data					
Rated speed	n_N	RPM	4500		
Number of poles	$2p$	---	10		
Rated torque (100K)	$M_{N(100K)}$	Nm	5		
Rated current	I_r	A	6,3		
Static torque (60 K)	$M_{0(60K)}$	Nm	10		
Static torque (100 K)	$M_{0(100K)}$	Nm	12		
Stall current (60 K)	$I_{0(60K)}$	A	10,1		
Stall current (100 K)	$I_{0(100K)}$	A	13,6		
Moment of inertia (with brake)	J_{MotBr}	10^{-4} kgm ²	19,3		
Moment of inertia (without brake)	J_{mot}	10^{-4} kgm ²	16,4		
Optimum operating point					
Optimum speed	n_{opt}	RPM	4000		
Optimum power	P_{opt}	kW	2,55		
Limiting data					
Max. permissible speed (mech.)	$n_{max\ mech.}$	RPM	9000		
Max. permissible speed (inverter)	$n_{max\ inv}$	RPM	8000		
Max. torque	M_{max}	Nm	49		
Maximum current	I_{max}	A	70		
Physical constants					
Torque constant	k_T	Nm/A	0,88		
Voltage constant	k_E	V/1000 RPM	56,5		
Winding resistance at 20° C	$R_{ph.}$	Ω	0,185		
Rotating field inductance	L_D	mH	2,3		
Electrical time constant	T_{el}	ms	12		
Mechanical time constant	T_{mech}	ms	1,2		
Thermal time constant	T_{th}	min	40		
Shaft torsional stiffness	C_t	Nm/rad	24000		
Weight with brake	m_{MotBr}	kg	14,1		
Weight without brake	m_{Mot}	kg	12,3		
Recommended Motor Module 6SL312□-□TE21-8AA□					
Rated inverter current	$I_{N\ Inv}$	A	18		
Maximum inverter current	$I_{max\ Inv}$	A	36		
Max. torque at $I_{max\ Inv}$	$M_{max\ Inv}$	Nm	30		

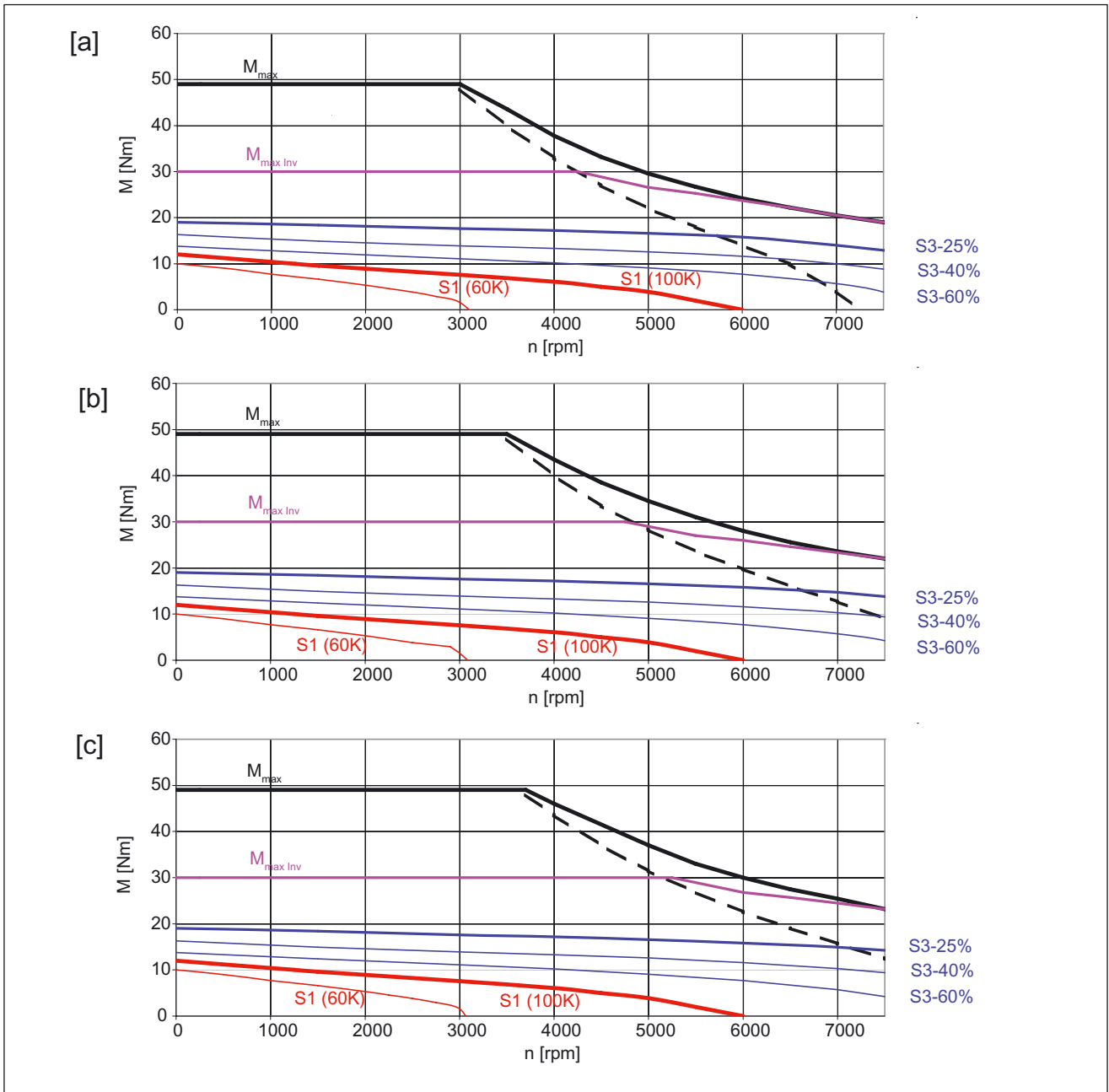

Figure 7-12 1FT7066-□AH7

- [a] SINAMICS SLM 400 V
- [b] SINAMICS ALM 400 V
- [c] SINAMICS SLM 480 V

The characteristic curves are only valid for optimized converter setting data

7.2 Technical data and characteristic curves

Table 7-13 1FT7068-□AF7

Technical data	Code	Unit	Value		
Engineering data					
Rated speed	n_N	RPM	3000		
Number of poles	2p	---	10		
Rated torque (100K)	$M_{N(100K)}$	Nm	10,9		
Rated current	I_r	A	6,7		
Static torque (60 K)	$M_{0(60K)}$	Nm	13		
Static torque (100 K)	$M_{0(100K)}$	Nm	15		
Stall current (60 K)	$I_{0(60K)}$	A	7,1		
Stall current (100 K)	$I_{0(100K)}$	A	8,3		
Moment of inertia (with brake)	J_{MotBr}	10^{-4} kgm ²	26,1		
Moment of inertia (without brake)	J_{mot}	10^{-4} kgm ²	23,2		
Optimum operating point					
Optimum speed	n_{opt}	RPM	3000		
Optimum power	P_{opt}	kW	3,42		
Limiting data					
Max. permissible speed (mech.)	$n_{max\ mech.}$	RPM	9000		
Max. permissible speed (inverter)	$n_{max\ inv}$	RPM	5100		
Max. torque	M_{max}	Nm	63		
Maximum current	I_{max}	A	43		
Physical constants					
Torque constant	k_T	Nm/A	1,81		
Voltage constant	k_E	V/1000 RPM	114		
Winding resistance at 20° C	$R_{ph.}$	Ω	0,53		
Rotating field inductance	L_D	mH	6,4		
Electrical time constant	T_{el}	ms	12		
Mechanical time constant	T_{mech}	ms	1,1		
Thermal time constant	T_{th}	min	45		
Shaft torsional stiffness	C_t	Nm/rad	21400		
Weight with brake	m_{MotBr}	kg	18		
Weight without brake	m_{Mot}	kg	16,3		
Recommended Motor Module 6SL312□-□TE21-0AA□					
Rated inverter current	$I_{N\ Inv}$	A	9		
Maximum inverter current	$I_{max\ Inv}$	A	18		
Max. torque at $I_{max\ Inv}$	$M_{max\ Inv}$	Nm	32		

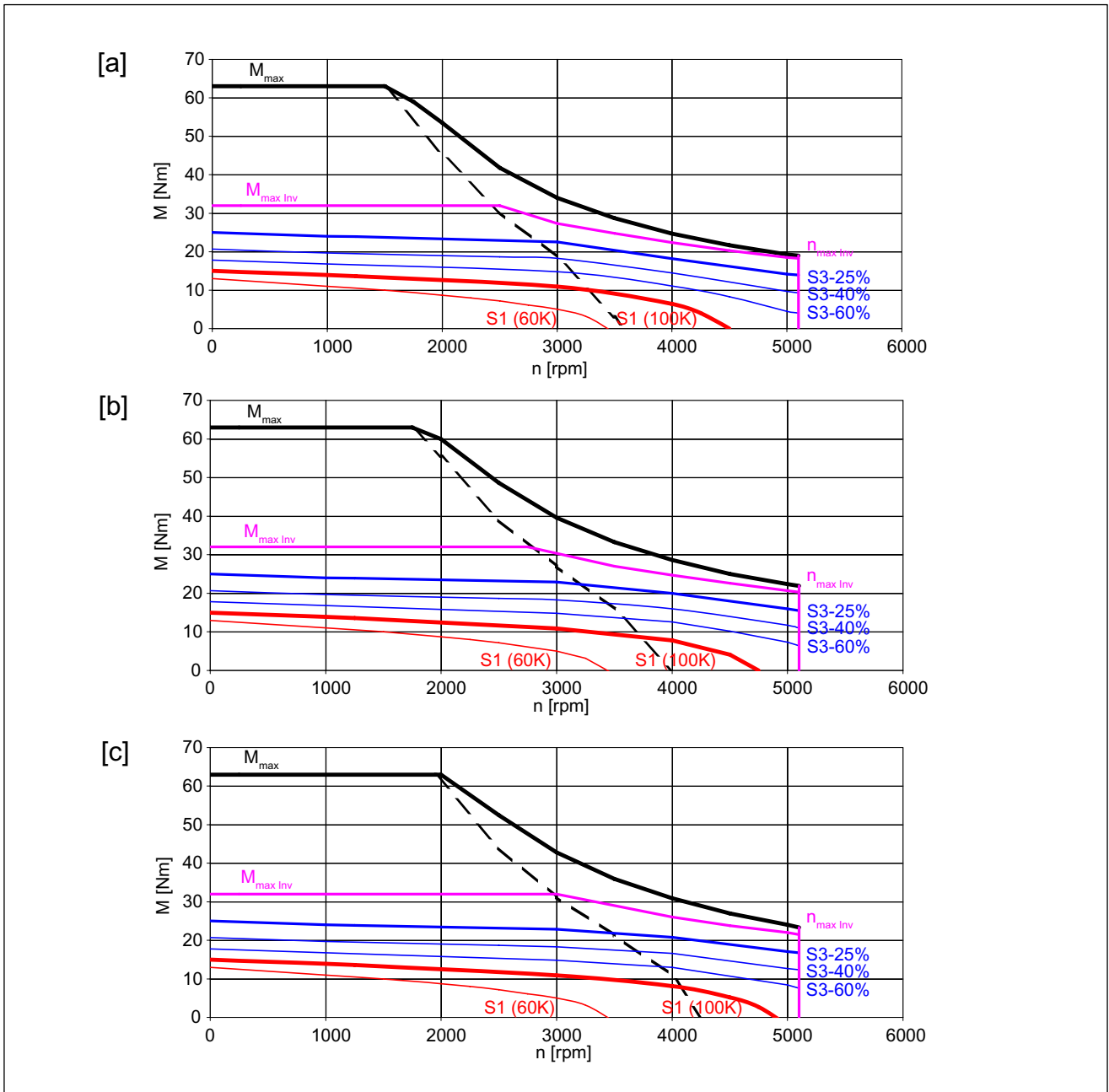

Figure 7-13 1FT7068-□AF7

- [a] SINAMICS SLM 400 V
- [b] SINAMICS ALM 400 V
- [c] SINAMICS SLM 480 V

The characteristic curves are only valid for optimized converter setting data

7.2 Technical data and characteristic curves

Table 7-14 1FT7082-□AC7

Technical data	Code	Unit	Value		
Engineering data					
Rated speed	n_N	RPM	2000		
Number of poles	2p	---	10		
Rated torque (100K)	$M_{N(100K)}$	Nm	11,4		
Rated current	I_r	A	4,9		
Static torque (60 K)	$M_{0(60K)}$	Nm	10,6		
Static torque (100 K)	$M_{0(100K)}$	Nm	13		
Stall current (60 K)	$I_{0(60K)}$	A	4		
Stall current (100 K)	$I_{0(100K)}$	A	5		
Moment of inertia (with brake)	J_{MotBr}	10^{-4} kgm ²	41,9		
Moment of inertia (without brake)	J_{mot}	10^{-4} kgm ²	26,5		
Optimum operating point					
Optimum speed	n_{opt}	RPM	2000		
Optimum power	P_{opt}	kW	2,39		
Limiting data					
Max. permissible speed (mech.)	$n_{max\ mech.}$	RPM	8000		
Max. permissible speed (inverter)	$n_{max\ inv}$	RPM	3500		
Max. torque	M_{max}	Nm	52		
Maximum current	I_{max}	A	26		
Physical constants					
Torque constant	k_T	Nm/A	2,60		
Voltage constant	k_E	V/1000 RPM	162		
Winding resistance at 20° C	$R_{ph.}$	Ω	1,38		
Rotating field inductance	L_D	mH	21		
Electrical time constant	T_{el}	ms	15		
Mechanical time constant	T_{mech}	ms	1,7		
Thermal time constant	T_{th}	min	40		
Shaft torsional stiffness	C_t	Nm/rad	75700		
Weight with brake	m_{MotBr}	kg	18,3		
Weight without brake	m_{Mot}	kg	14		
Recommended Motor Module 6SL312□-□TE15-0AA□					
Rated inverter current	$I_{N\ Inv}$	A	5		
Maximum inverter current	$I_{max\ Inv}$	A	10		
Max. torque at $I_{max\ Inv}$	$M_{max\ Inv}$	Nm	24		

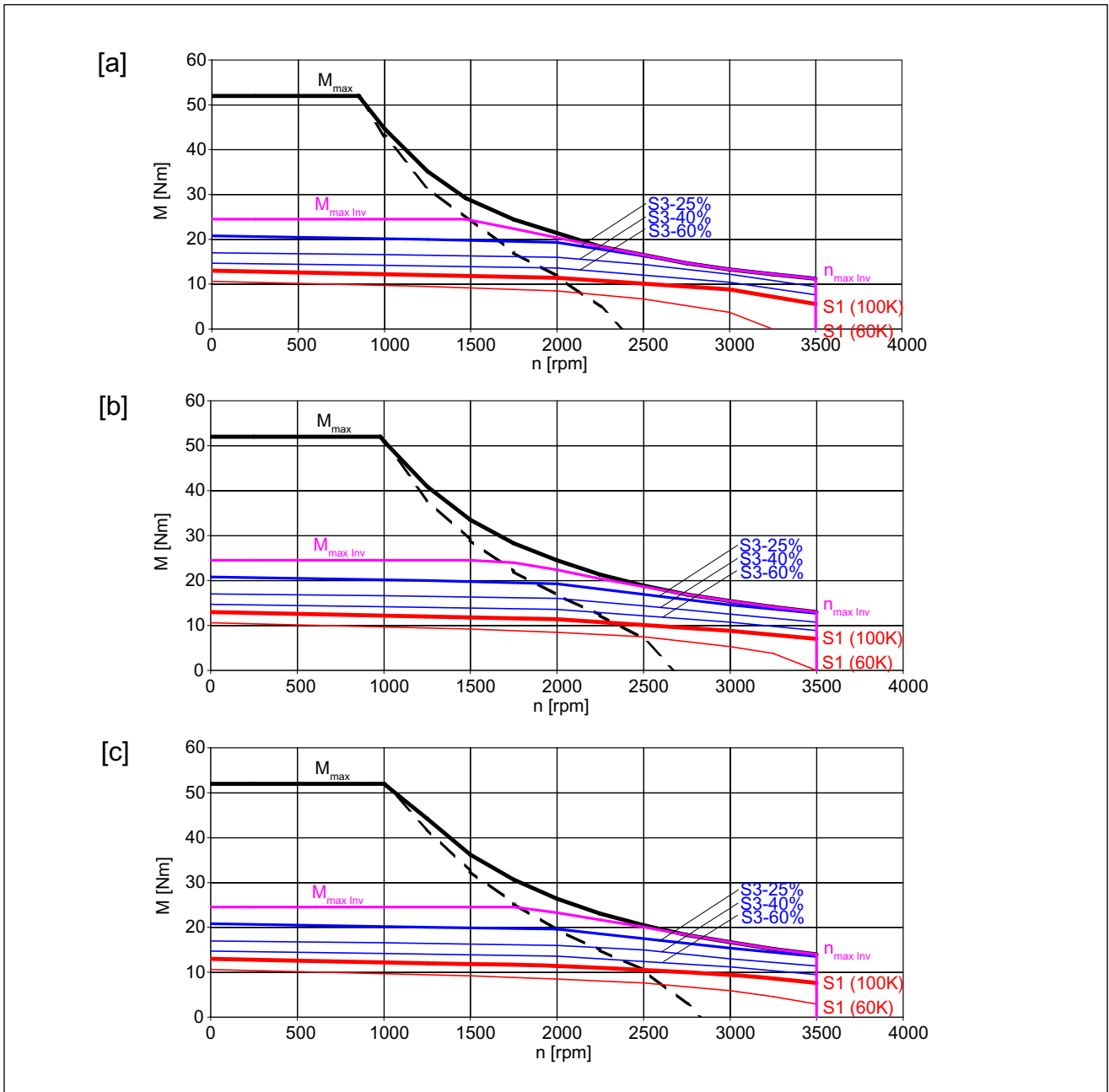

Figure 7-14 1FT7082-□AC7

- [a] SINAMICS SLM 400 V
- [b] SINAMICS ALM 400 V
- [c] SINAMICS SLM 480 V

The characteristic curves are only valid for optimized converter setting data

7.2 Technical data and characteristic curves

Table 7-15 1FT7082-□AF7

Technical data	Code	Unit	Value		
Engineering data					
Rated speed	n_N	RPM	3000		
Number of poles	$2p$	---	10		
Rated torque (100K)	$M_{N(100K)}$	Nm	10,3		
Rated current	I_r	A	6,6		
Static torque (60 K)	$M_{0(60K)}$	Nm	10,6		
Static torque (100 K)	$M_{0(100K)}$	Nm	13		
Stall current (60 K)	$I_{0(60K)}$	A	6,1		
Stall current (100 K)	$I_{0(100K)}$	A	7,6		
Moment of inertia (with brake)	J_{MotBr}	10^{-4} kgm ²	41,9		
Moment of inertia (without brake)	J_{mot}	10^{-4} kgm ²	26,5		
Optimum operating point					
Optimum speed	n_{opt}	RPM	3000		
Optimum power	P_{opt}	kW	3,24		
Limiting data					
Max. permissible speed (mech.)	$n_{max\ mech.}$	RPM	8000		
Max. permissible speed (inverter)	$n_{max\ inv}$	RPM	5400		
Max. torque	M_{max}	Nm	52		
Maximum current	I_{max}	A	39		
Physical constants					
Torque constant	k_T	Nm/A	1,71		
Voltage constant	k_E	V/1000 RPM	108		
Winding resistance at 20° C	$R_{ph.}$	Ω	0,59		
Rotating field inductance	L_D	mH	9,3		
Electrical time constant	T_{el}	ms	16		
Mechanical time constant	T_{mech}	ms	1,6		
Thermal time constant	T_{th}	min	40		
Shaft torsional stiffness	C_t	Nm/rad	75700		
Weight with brake	m_{MotBr}	kg	18,3		
Weight without brake	m_{Mot}	kg	14		
Recommended Motor Module 6SL312□-□TE21-0AA□					
Rated inverter current	$I_{N\ Inv}$	A	9		
Maximum inverter current	$I_{max\ Inv}$	A	18		
Max. torque at $I_{max\ Inv}$	$M_{max\ Inv}$	Nm	28		

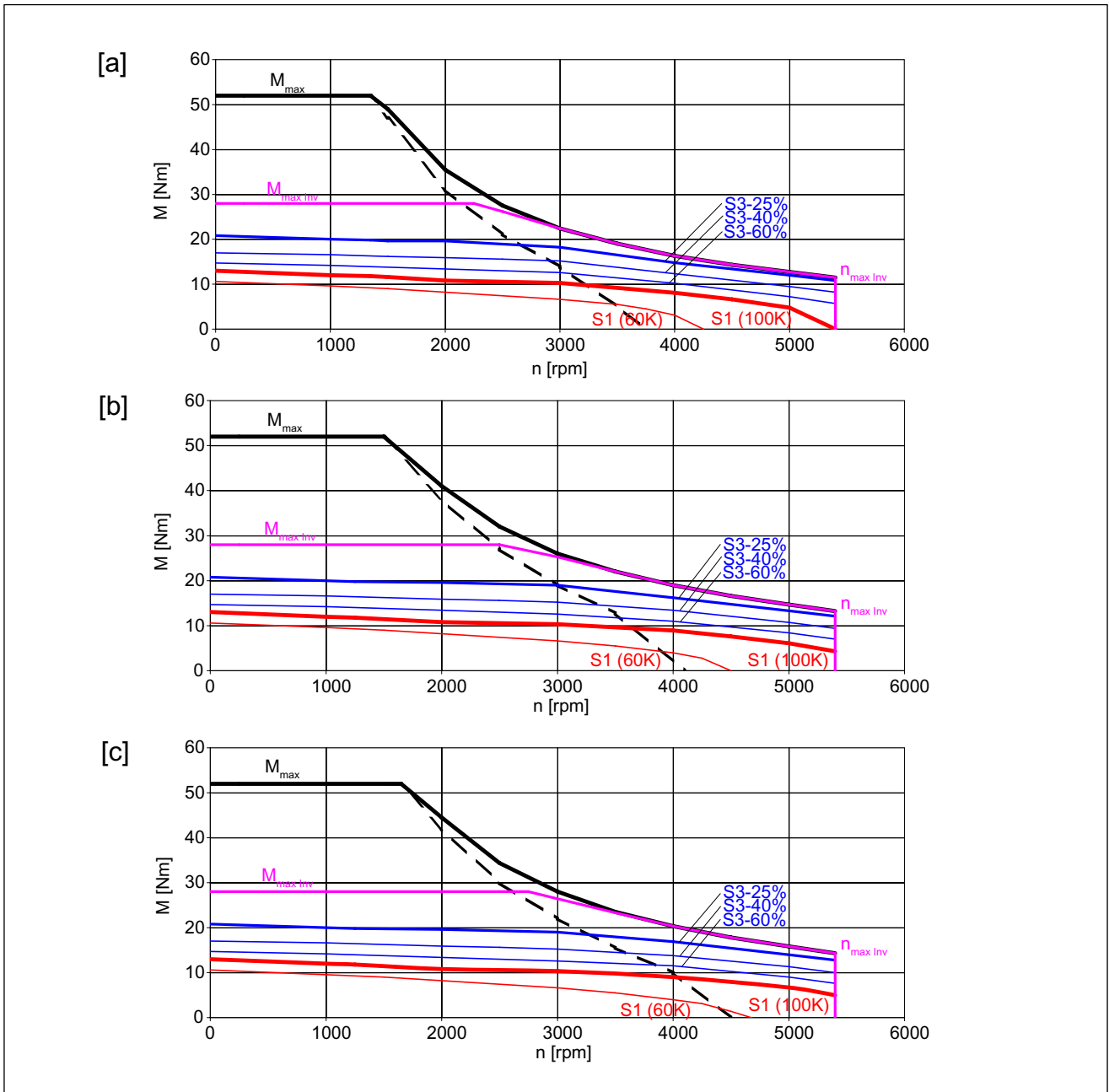

Figure 7-15 1FT7082-□AF7

- [a] SINAMICS SLM 400 V
- [b] SINAMICS ALM 400 V
- [c] SINAMICS SLM 480 V

The characteristic curves are only valid for optimized converter setting data

7.2 Technical data and characteristic curves

Table 7-16 1FT7082-□AH7

Technical data	Code	Unit	Value		
Engineering data					
Rated speed	n_N	RPM	4500		
Number of poles	2p	---	10		
Rated torque (100K)	$M_{N(100K)}$	Nm	8		
Rated current	I_r	A	7,8		
Static torque (60 K)	$M_{0(60K)}$	Nm	10,6		
Static torque (100 K)	$M_{0(100K)}$	Nm	13		
Stall current (60 K)	$I_{0(60K)}$	A	10		
Stall current (100 K)	$I_{0(100K)}$	A	12,3		
Moment of inertia (with brake)	J_{MotBr}	10^{-4} kgm ²	41,9		
Moment of inertia (without brake)	J_{mot}	10^{-4} kgm ²	26,5		
Optimum operating point					
Optimum speed	n_{opt}	RPM	4500		
Optimum power	P_{opt}	kW	3,77		
Limiting data					
Max. permissible speed (mech.)	$n_{max\ mech.}$	RPM	8000		
Max. permissible speed (inverter)	$n_{max\ inv}$	RPM	8000		
Max. torque	M_{max}	Nm	52		
Maximum current	I_{max}	A	63		
Physical constants					
Torque constant	k_T	Nm/A	1,06		
Voltage constant	k_E	V/1000 RPM	66,5		
Winding resistance at 20° C	$R_{ph.}$	Ω	0,23		
Rotating field inductance	L_D	mH	3,5		
Electrical time constant	T_{el}	ms	15		
Mechanical time constant	T_{mech}	ms	1,6		
Thermal time constant	T_{th}	min	40		
Shaft torsional stiffness	C_t	Nm/rad	75700		
Weight with brake	m_{MotBr}	kg	18,3		
Weight without brake	m_{Mot}	kg	14		
Recommended Motor Module 6SL312□-□TE21-8AA□					
Rated inverter current	$I_{N\ Inv}$	A	18		
Maximum inverter current	$I_{max\ Inv}$	A	36		
Max. torque at $I_{max\ Inv}$	$M_{max\ Inv}$	Nm	34		

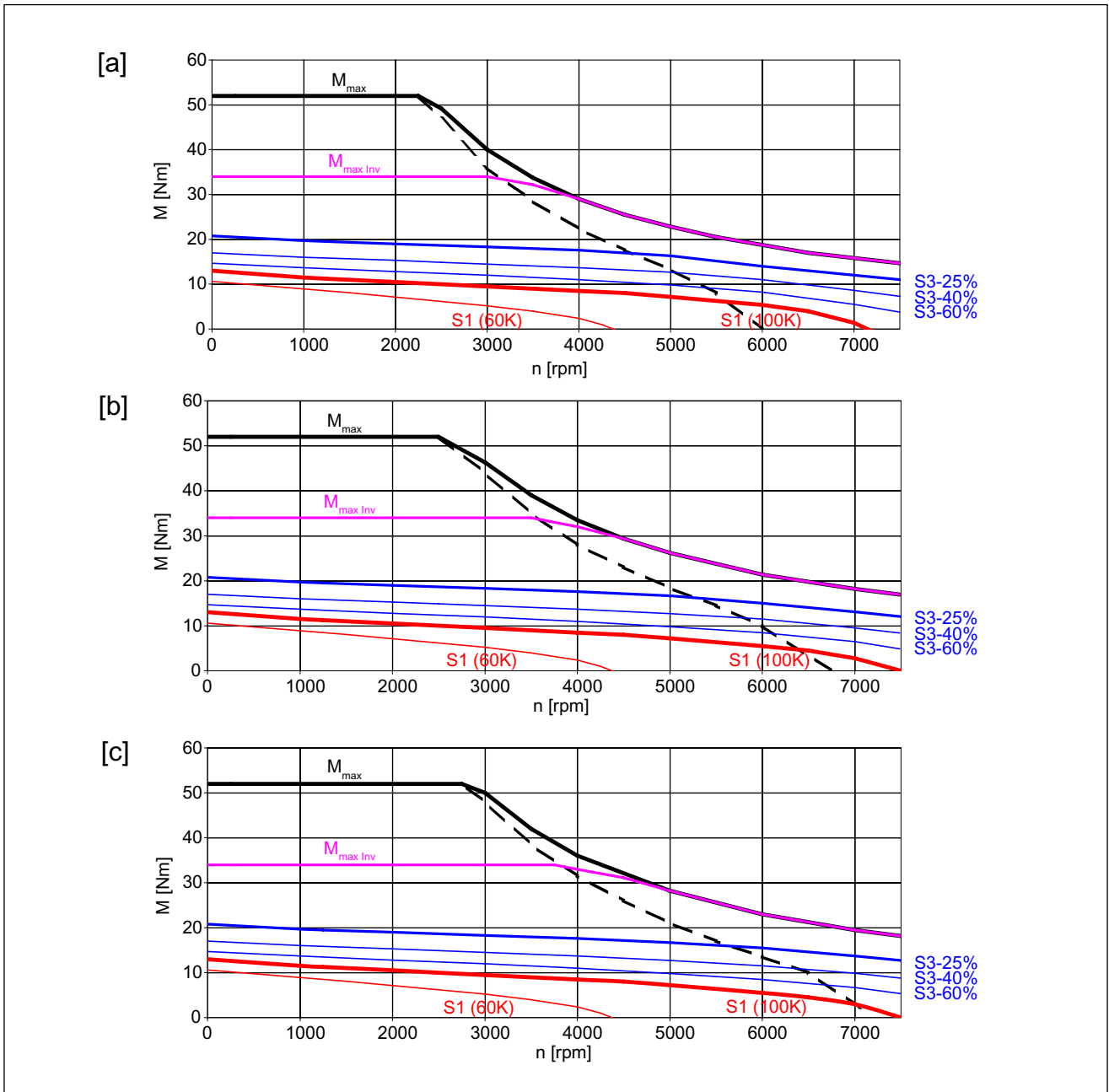

Figure 7-16 1FT7082-□AH7

- [a] SINAMICS SLM 400 V
- [b] SINAMICS ALM 400 V
- [c] SINAMICS SLM 480 V

The characteristic curves are only valid for optimized converter setting data

7.2 Technical data and characteristic curves

Table 7-17 1FT7084-□AC7

Technical data	Code	Unit	Value		
Engineering data					
Rated speed	n_N	RPM	2000		
Number of poles	2p	---	10		
Rated torque (100K)	$M_{N(100K)}$	Nm	16,9		
Rated current	I_r	A	8,4		
Static torque (60 K)	$M_{0(60K)}$	Nm	16,8		
Static torque (100 K)	$M_{0(100K)}$	Nm	20		
Stall current (60 K)	$I_{0(60K)}$	A	7,4		
Stall current (100 K)	$I_{0(100K)}$	A	9		
Moment of inertia (with brake)	J_{MotBr}	10^{-4} kgm ²	60,4		
Moment of inertia (without brake)	J_{mot}	10^{-4} kgm ²	45,1		
Optimum operating point					
Optimum speed	n_{opt}	RPM	2000		
Optimum power	P_{opt}	kW	3,54		
Limiting data					
Max. permissible speed (mech.)	$n_{max\ mech.}$	RPM	8000		
Max. permissible speed (inverter)	$n_{max\ inv}$	RPM	4200		
Max. torque	M_{max}	Nm	81		
Maximum current	I_{max}	A	46		
Physical constants					
Torque constant	k_T	Nm/A	2,22		
Voltage constant	k_E	V/1000 RPM	142		
Winding resistance at 20° C	$R_{ph.}$	Ω	0,52		
Rotating field inductance	L_D	mH	8,5		
Electrical time constant	T_{el}	ms	16		
Mechanical time constant	T_{mech}	ms	1,5		
Thermal time constant	T_{th}	min	55		
Shaft torsional stiffness	C_t	Nm/rad	65100		
Weight with brake	m_{MotBr}	kg	25,1		
Weight without brake	m_{Mot}	kg	20,8		
Recommended Motor Module 6SL312□-□TE21-0AA□					
Rated inverter current	$I_{N\ Inv}$	A	9		
Maximum inverter current	$I_{max\ Inv}$	A	18		
Max. torque at $I_{max\ Inv}$	$M_{max\ Inv}$	Nm	35		

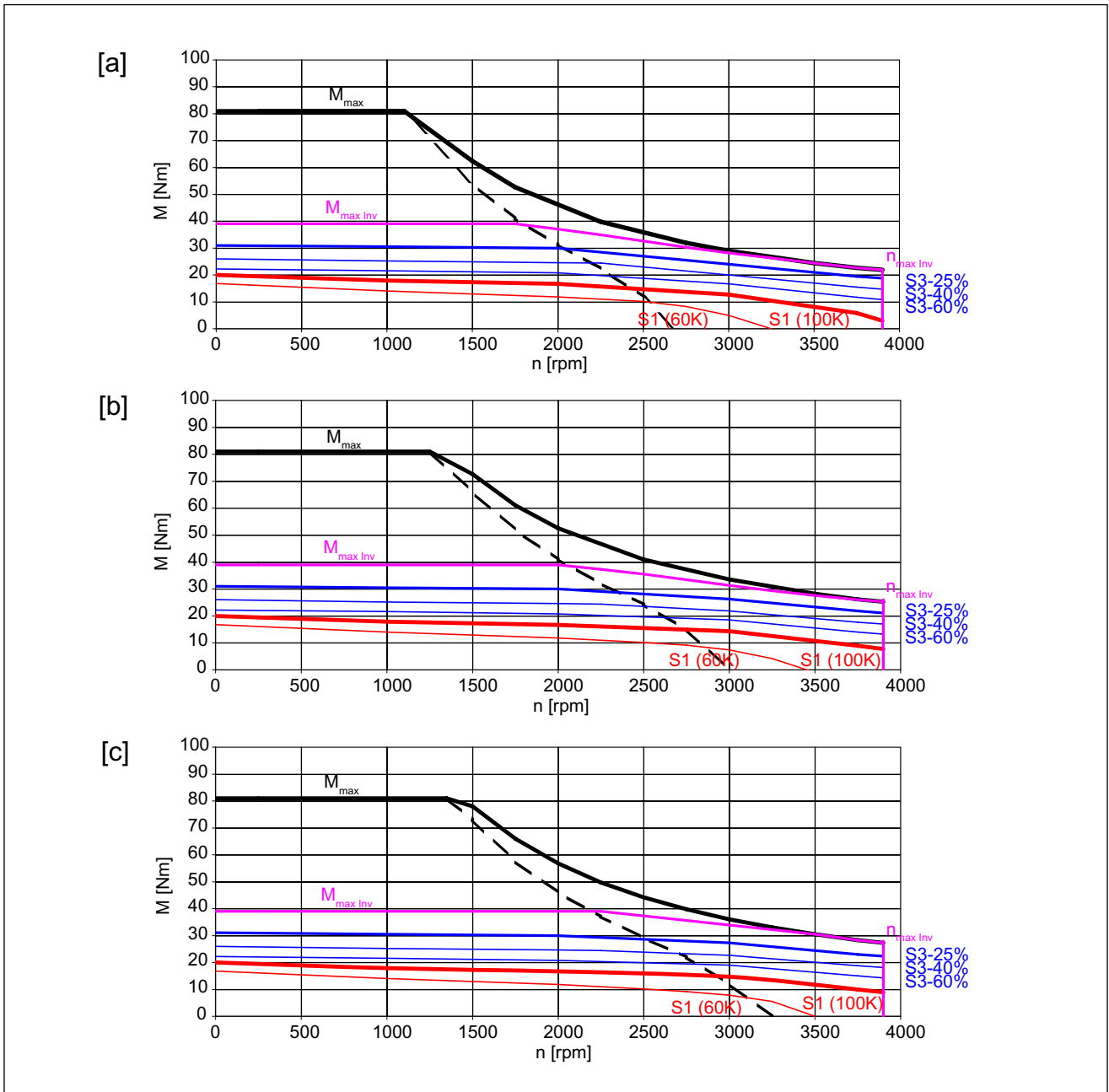

Figure 7-17 1FT7084-□AC7

- [a] SINAMICS SLM 400 V
- [b] SINAMICS ALM 400 V
- [c] SINAMICS SLM 480 V

The characteristic curves are only valid for optimized converter setting data

7.2 Technical data and characteristic curves

Table 7-18 1FT7084-□AF7

Technical data	Code	Unit	Value		
Engineering data					
Rated speed	n_N	RPM	3000		
Number of poles	2p	---	10		
Rated torque (100K)	$M_{N(100K)}$	Nm	14,5		
Rated current	I_r	A	8,5		
Static torque (60 K)	$M_{0(60K)}$	Nm	16,8		
Static torque (100 K)	$M_{0(100K)}$	Nm	20		
Stall current (60 K)	$I_{0(60K)}$	A	8,5		
Stall current (100 K)	$I_{0(100K)}$	A	11		
Moment of inertia (with brake)	J_{MotBr}	10^{-4} kgm ²	60,4		
Moment of inertia (without brake)	J_{mot}	10^{-4} kgm ²	45,1		
Optimum operating point					
Optimum speed	n_{opt}	RPM	3000		
Optimum power	P_{opt}	kW	4,55		
Limiting data					
Max. permissible speed (mech.)	$n_{max\ mech.}$	RPM	8000		
Max. permissible speed (inverter)	$n_{max\ inv}$	RPM	5000		
Max. torque	M_{max}	Nm	81		
Maximum current	I_{max}	A	55		
Physical constants					
Torque constant	k_T	Nm/A	1,82		
Voltage constant	k_E	V/1000 RPM	116		
Winding resistance at 20° C	$R_{ph.}$	Ω	0,34		
Rotating field inductance	L_D	mH	6		
Electrical time constant	T_{el}	ms	18		
Mechanical time constant	T_{mech}	ms	1,4		
Thermal time constant	T_{th}	min	55		
Shaft torsional stiffness	C_t	Nm/rad	65100		
Weight with brake	m_{MotBr}	kg	25,1		
Weight without brake	m_{Mot}	kg	20,8		
Recommended Motor Module 6SL312□-□TE21-8AA□					
Rated inverter current	$I_{N\ Inv}$	A	18		
Maximum inverter current	$I_{max\ Inv}$	A	36		
Max. torque at $I_{max\ Inv}$	$M_{max\ Inv}$	Nm	58		

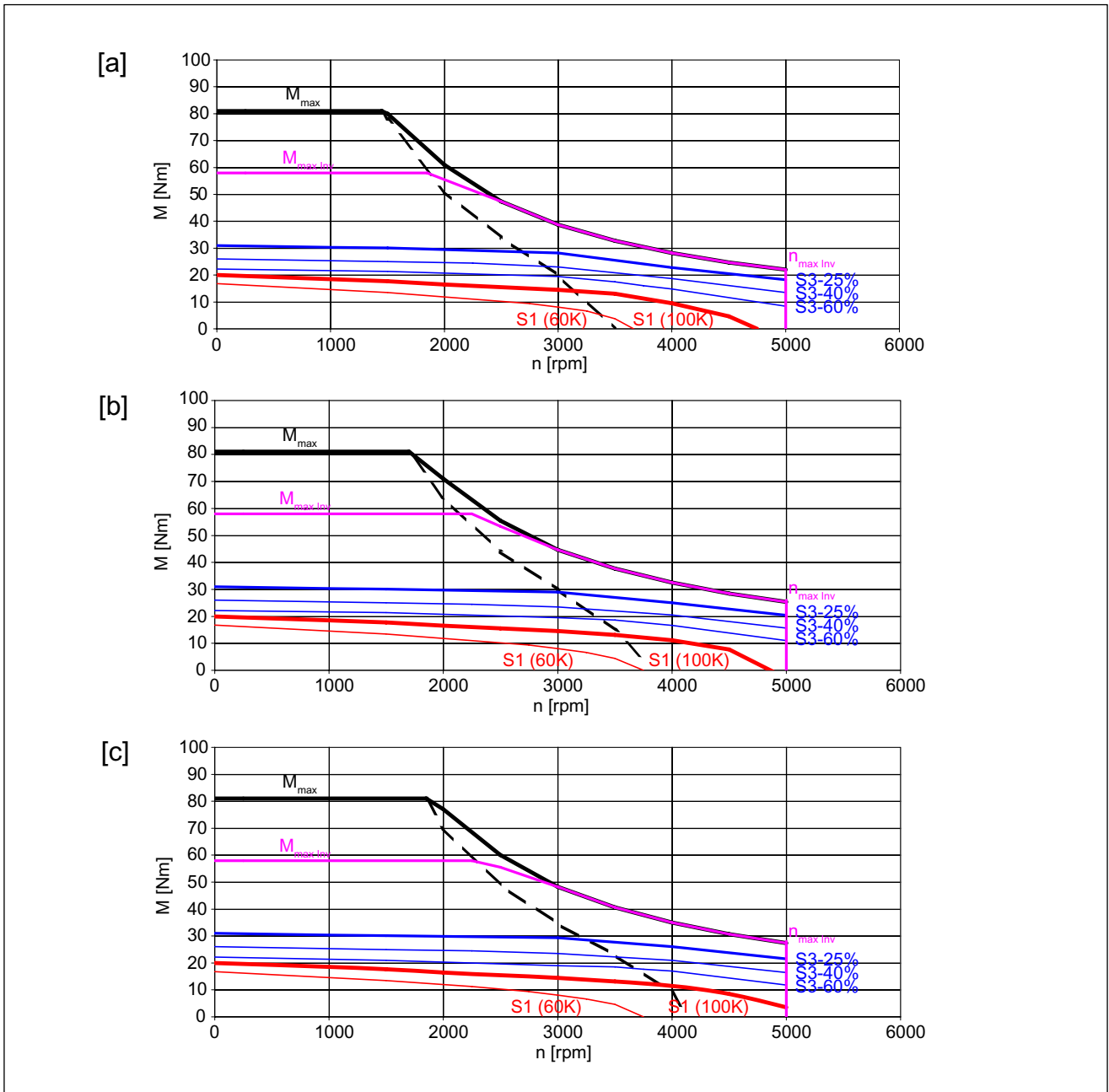

Figure 7-18 1FT7084-□AF7

- [a] SINAMICS SLM 400 V
- [b] SINAMICS ALM 400 V
- [c] SINAMICS SLM 480 V

The characteristic curves are only valid for optimized converter setting data

7.2 Technical data and characteristic curves

Table 7-19 1FT7084-□AH7

Technical data	Code	Unit	Value		
Engineering data					
Rated speed	n_N	RPM	4500		
Number of poles	2p	---	10		
Rated torque (100K)	$M_{N(100K)}$	Nm	9,5		
Rated current	I_r	A	7,8		
Static torque (60 K)	$M_{0(60K)}$	Nm	16,8		
Static torque (100 K)	$M_{0(100K)}$	Nm	20		
Stall current (60 K)	$I_{0(60K)}$	A	13		
Stall current (100 K)	$I_{0(100K)}$	A	15,6		
Moment of inertia (with brake)	J_{MotBr}	10^{-4} kgm ²	60,4		
Moment of inertia (without brake)	J_{mot}	10^{-4} kgm ²	45,1		
Optimum operating point					
Optimum speed	n_{opt}	RPM	4000		
Optimum power	P_{opt}	kW	4,82		
Limiting data					
Max. permissible speed (mech.)	$n_{max\ mech.}$	RPM	8000		
Max. permissible speed (inverter)	$n_{max\ inv}$	RPM	7200		
Max. torque	M_{max}	Nm	81		
Maximum current	I_{max}	A	80		
Physical constants					
Torque constant	k_T	Nm/A	1,28		
Voltage constant	k_E	V/1000 RPM	80		
Winding resistance at 20° C	$R_{ph.}$	Ω	0,17		
Rotating field inductance	L_D	mH	2,9		
Electrical time constant	T_{el}	ms	17		
Mechanical time constant	T_{mech}	ms	1,4		
Thermal time constant	T_{th}	min	55		
Shaft torsional stiffness	C_t	Nm/rad	65100		
Weight with brake	m_{MotBr}	kg	25,1		
Weight without brake	m_{Mot}	kg	20,8		
Recommended Motor Module 6SL312□-□TE21-8AA□					
Rated inverter current	$I_{N\ Inv}$	A	18		
Maximum inverter current	$I_{max\ Inv}$	A	36		
Max. torque at $I_{max\ Inv}$	$M_{max\ Inv}$	Nm	42		

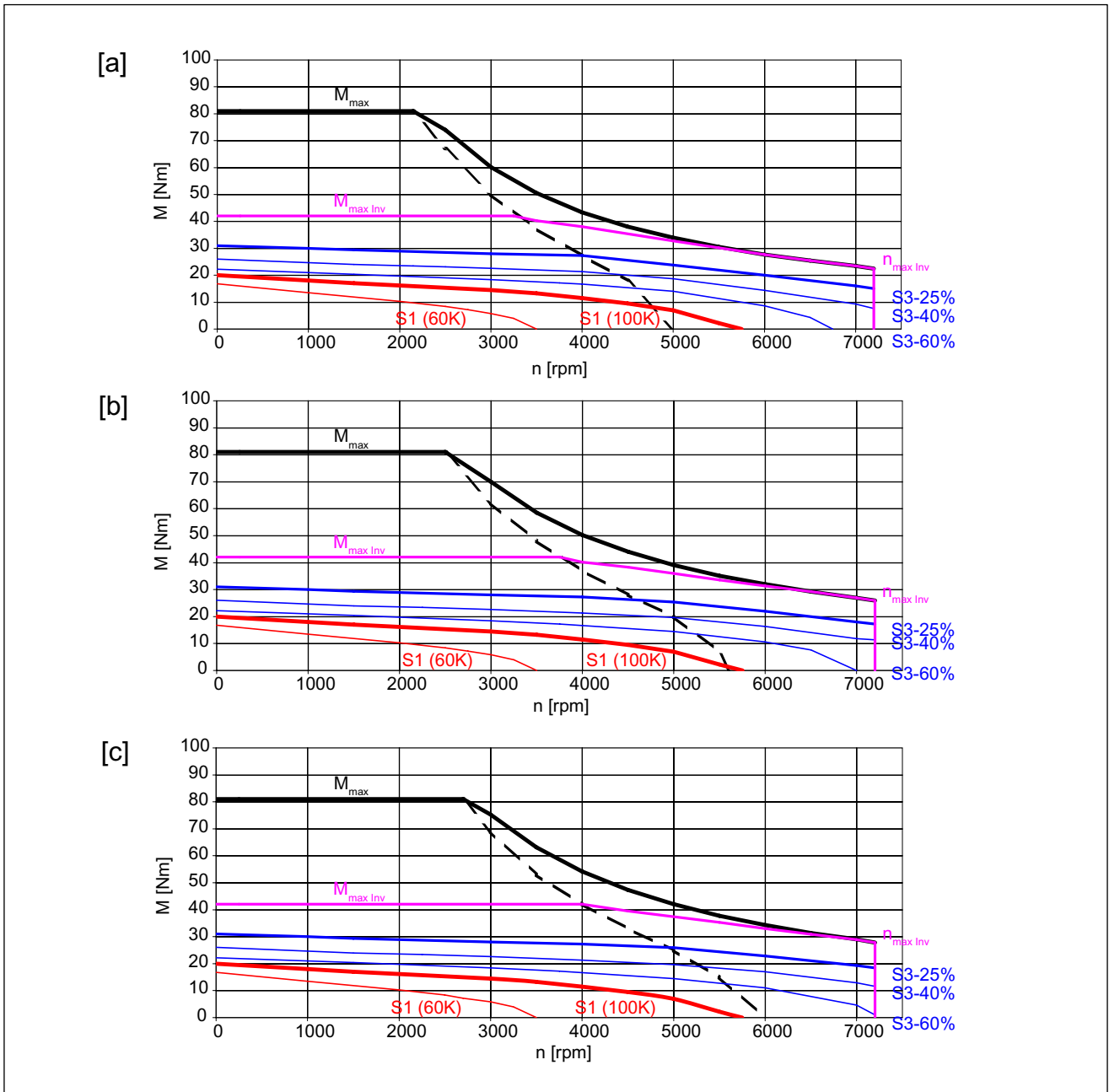

Figure 7-19 1FT7084-□AH7

- [a] SINAMICS SLM 400 V
- [b] SINAMICS ALM 400 V
- [c] SINAMICS SLM 480 V

The characteristic curves are only valid for optimized converter setting data

7.2 Technical data and characteristic curves

Table 7-20 1FT7086-□AC7

Technical data	Code	Unit	Value		
Engineering data					
Rated speed	n_N	RPM	2000		
Number of poles	2p	---	10		
Rated torque (100K)	$M_{N(100K)}$	Nm	22,5		
Rated current	I_r	A	9,2		
Static torque (60 K)	$M_{0(60K)}$	Nm	23		
Static torque (100 K)	$M_{0(100K)}$	Nm	28		
Stall current (60 K)	$I_{0(60K)}$	A	8,6		
Stall current (100 K)	$I_{0(100K)}$	A	10,6		
Moment of inertia (with brake)	J_{MotBr}	10^{-4} kgm ²	79		
Moment of inertia (without brake)	J_{mot}	10^{-4} kgm ²	63,6		
Optimum operating point					
Optimum speed	n_{opt}	RPM	2000		
Optimum power	P_{opt}	kW	4,71		
Limiting data					
Max. permissible speed (mech.)	$n_{max\ mech.}$	RPM	8000		
Max. permissible speed (inverter)	$n_{max\ inv}$	RPM	3500		
Max. torque	M_{max}	Nm	120		
Maximum current	I_{max}	A	54		
Physical constants					
Torque constant	k_T	Nm/A	2,64		
Voltage constant	k_E	V/1000 RPM	166		
Winding resistance at 20° C	$R_{ph.}$	Ω	0,46		
Rotating field inductance	L_D	mH	8,5		
Electrical time constant	T_{el}	ms	18		
Mechanical time constant	T_{mech}	ms	1,3		
Thermal time constant	T_{th}	min	60		
Shaft torsional stiffness	C_t	Nm/rad	57000		
Weight with brake	m_{MotBr}	kg	31,8		
Weight without brake	m_{Mot}	kg	27,5		
Recommended Motor Module 6SL312□-□TE21-8AA□					
Rated inverter current	$I_{N\ Inv}$	A	18		
Maximum inverter current	$I_{max\ Inv}$	A	36		
Max. torque at $I_{max\ Inv}$	$M_{max\ Inv}$	Nm	86		

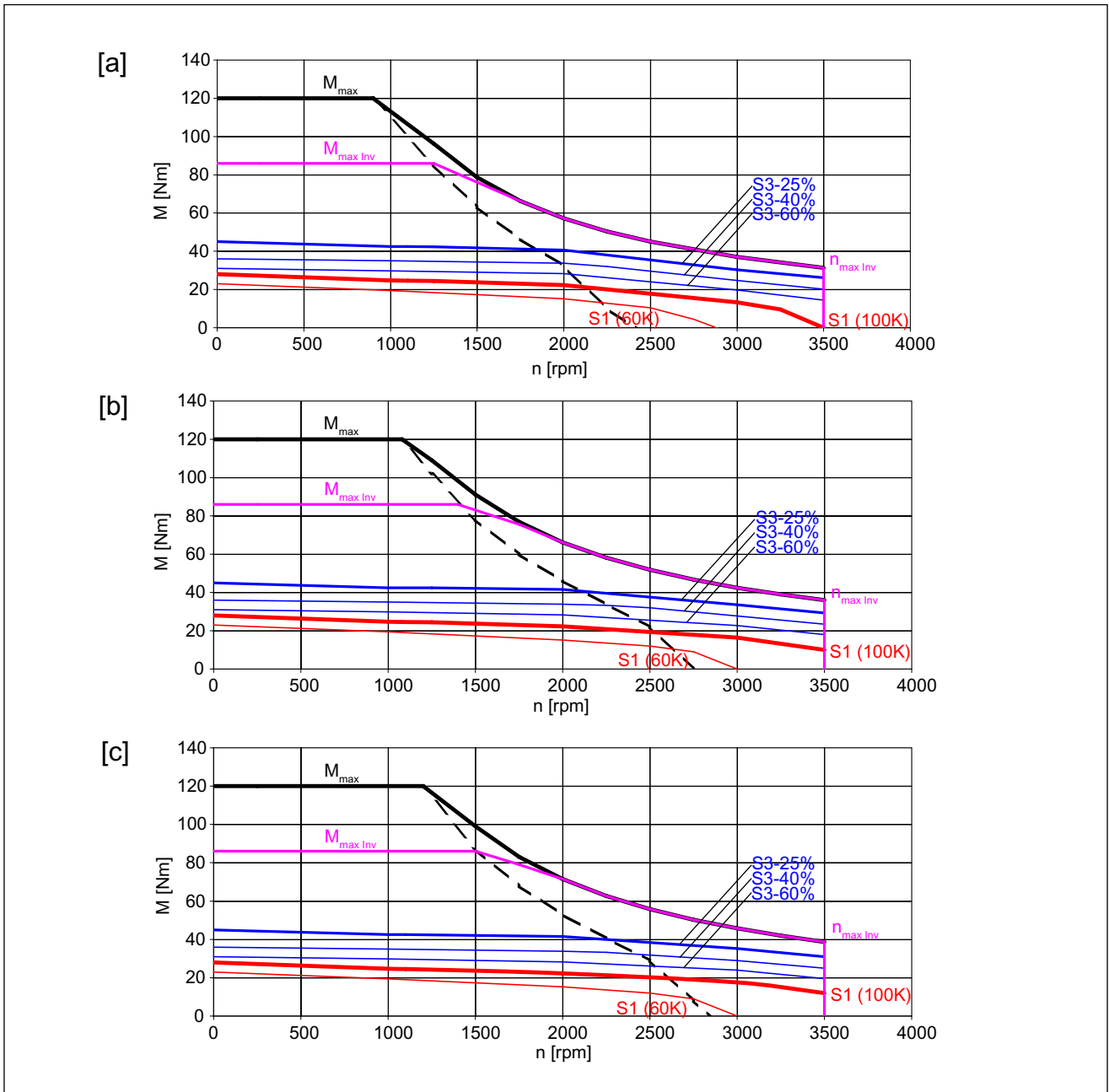

Figure 7-20 1FT7086-□AC7

- [a] SINAMICS SLM 400 V
- [b] SINAMICS ALM 400 V
- [c] SINAMICS SLM 480 V

The characteristic curves are only valid for optimized converter setting data

7.2 Technical data and characteristic curves

Table 7-21 1FT7086-□AF7

Technical data	Code	Unit	Value		
Engineering data					
Rated speed	n_N	RPM	3000		
Number of poles	2p	---	10		
Rated torque (100K)	$M_{N(100K)}$	Nm	18		
Rated current	I_r	A	11		
Static torque (60 K)	$M_{0(60K)}$	Nm	23		
Static torque (100 K)	$M_{0(100K)}$	Nm	28		
Stall current (60 K)	$I_{0(60K)}$	A	12,5		
Stall current (100 K)	$I_{0(100K)}$	A	15,5		
Moment of inertia (with brake)	J_{MotBr}	10^{-4} kgm ²	79		
Moment of inertia (without brake)	J_{mot}	10^{-4} kgm ²	63,6		
Optimum operating point					
Optimum speed	n_{opt}	RPM	3000		
Optimum power	P_{opt}	kW	5,65		
Limiting data					
Max. permissible speed (mech.)	$n_{max\ mech.}$	RPM	8000		
Max. permissible speed (inverter)	$n_{max\ inv}$	RPM	5100		
Max. torque	M_{max}	Nm	120		
Maximum current	I_{max}	A	78		
Physical constants					
Torque constant	k_T	Nm/A	1,81		
Voltage constant	k_E	V/1000 RPM	114		
Winding resistance at 20° C	$R_{ph.}$	Ω	0,23		
Rotating field inductance	L_D	mH	4		
Electrical time constant	T_{el}	ms	17		
Mechanical time constant	T_{mech}	ms	1,3		
Thermal time constant	T_{th}	min	60		
Shaft torsional stiffness	C_t	Nm/rad	57000		
Weight with brake	m_{MotBr}	kg	31,8		
Weight without brake	m_{Mot}	kg	27,5		
Recommended Motor Module 6SL312□-□TE21-8AA□					
Rated inverter current	$I_{N\ Inv}$	A	18		
Maximum inverter current	$I_{max\ Inv}$	A	36		
Max. torque at $I_{max\ Inv}$	$M_{max\ Inv}$	Nm	60		

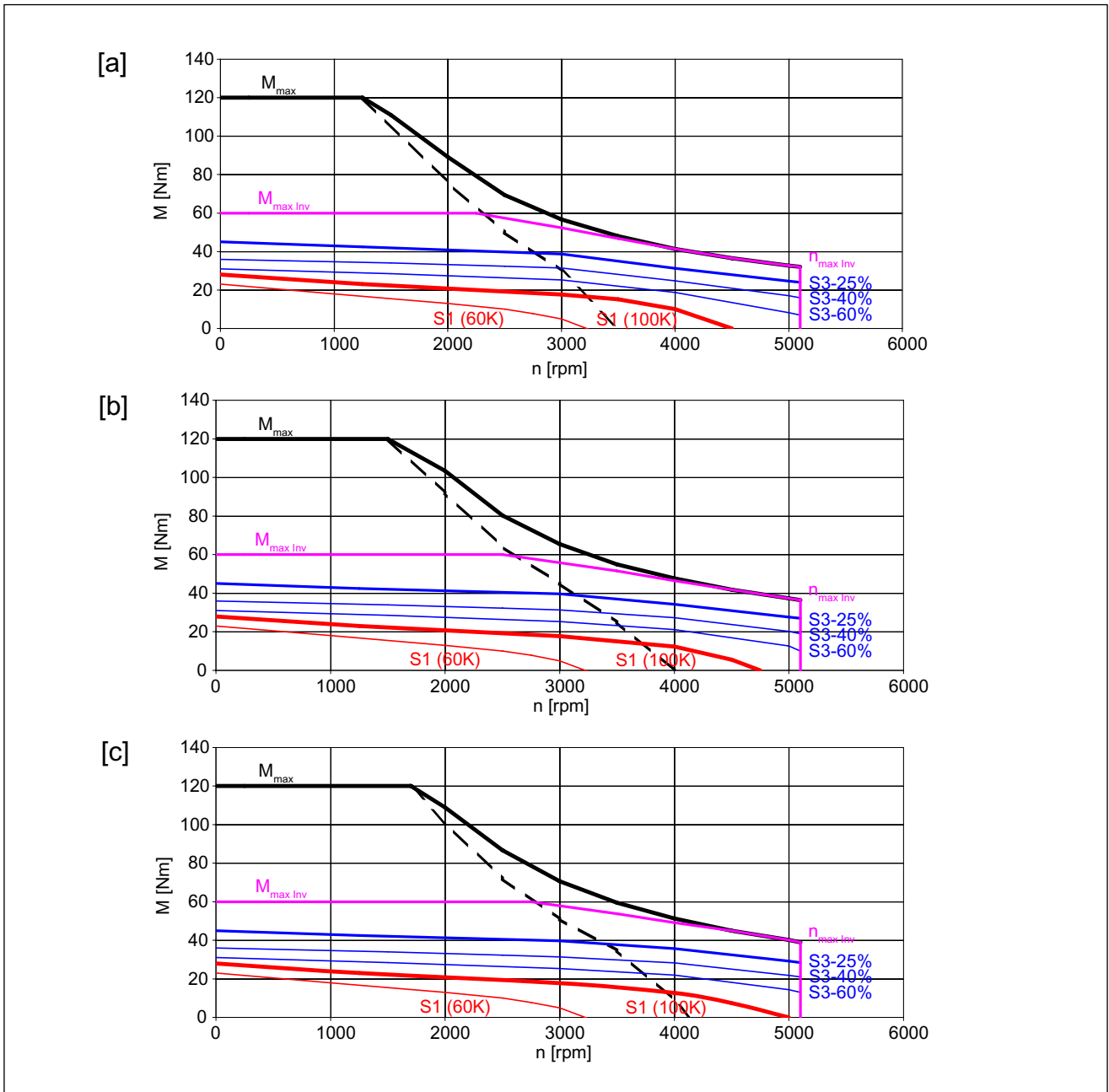

Figure 7-21 1FT7086-□AF7

- [a] SINAMICS SLM 400 V
- [b] SINAMICS ALM 400 V
- [c] SINAMICS SLM 480 V

The characteristic curves are only valid for optimized converter setting data

7.2 Technical data and characteristic curves

Table 7-22 1FT7102-□AB7

Technical data	Code	Unit	Value		
Engineering data					
Rated speed	n_N	RPM	1500		
Number of poles	2p	---	10		
Rated torque (100K)	$M_{N(100K)}$	Nm	26		
Rated current	I_r	A	8		
Static torque (60 K)	$M_{0(60K)}$	Nm	25		
Static torque (100 K)	$M_{0(100K)}$	Nm	30		
Stall current (60 K)	$I_{0(60K)}$	A	7,5		
Stall current (100 K)	$I_{0(100K)}$	A	9		
Moment of inertia (with brake)	J_{MotBr}	10^{-4} kgm ²	119		
Moment of inertia (without brake)	J_{mot}	10^{-4} kgm ²	91,4		
Optimum operating point					
Optimum speed	n_{opt}	RPM	1500		
Optimum power	P_{opt}	kW	4,08		
Limiting data					
Max. permissible speed (mech.)	$n_{max\ mech.}$	RPM	6000		
Max. permissible speed (inverter)	$n_{max\ inv}$	RPM	2680		
Max. torque	M_{max}	Nm	120		
Maximum current	I_{max}	A	45		
Physical constants					
Torque constant	k_T	Nm/A	3,33		
Voltage constant	k_E	V/1000 RPM	216		
Winding resistance at 20° C	$R_{ph.}$	Ω	0,59		
Rotating field inductance	L_D	mH	12,5		
Electrical time constant	T_{el}	ms	21		
Mechanical time constant	T_{mech}	ms	1,5		
Thermal time constant	T_{th}	min	70		
Shaft torsional stiffness	C_t	Nm/rad	124000		
Weight with brake	m_{MotBr}	kg	32,3		
Weight without brake	m_{Mot}	kg	26,1		
Recommended Motor Module 6SL312□-□TE21-0AA□					
Rated inverter current	$I_{N\ Inv}$	A	9		
Maximum inverter current	$I_{max\ Inv}$	A	18		
Max. torque at $I_{max\ Inv}$	$M_{max\ Inv}$	Nm	56		

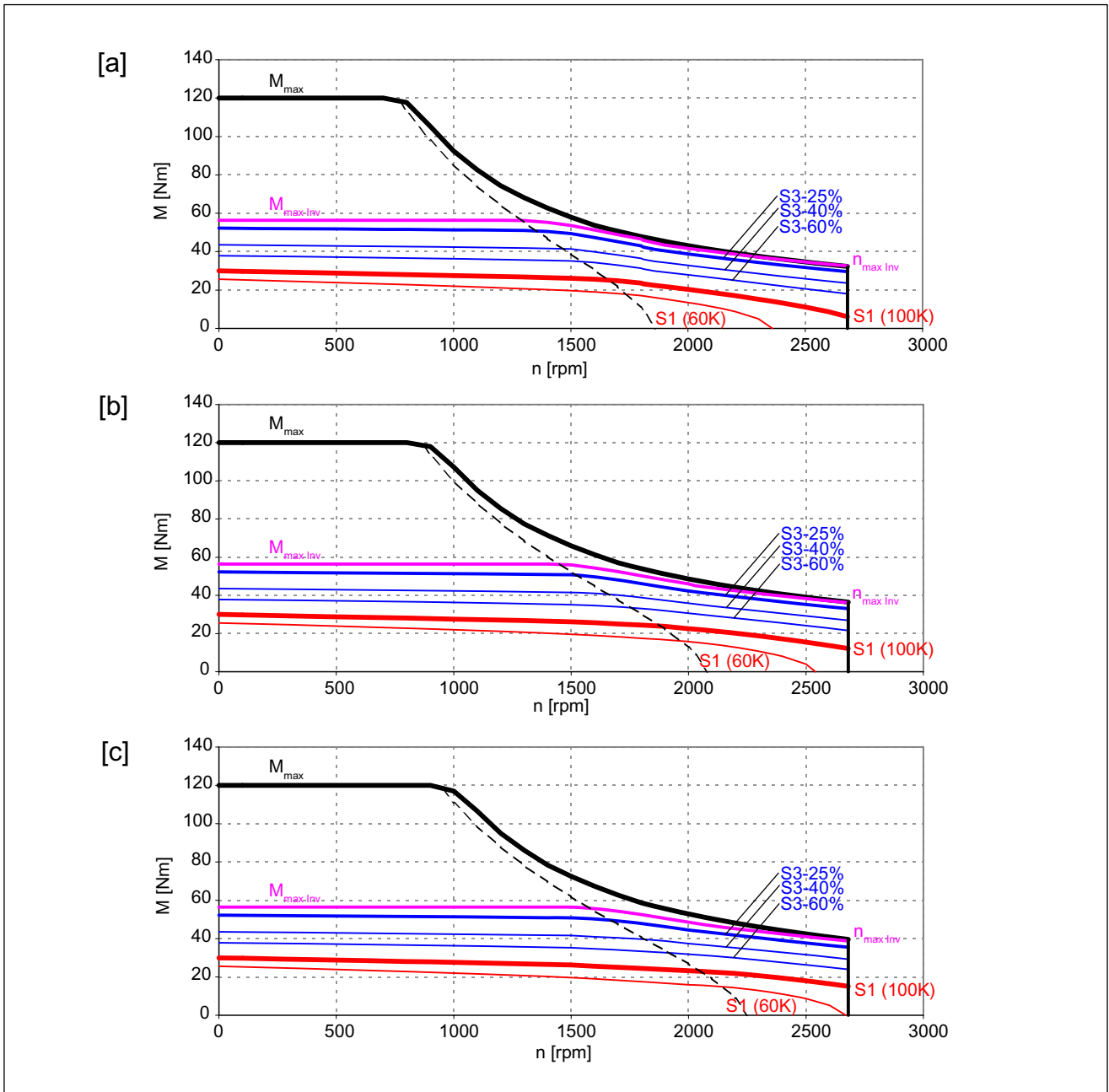

Figure 7-22 1FT7102-□AB7

- [a] SINAMICS SLM 400 V
- [b] SINAMICS ALM 400 V
- [c] SINAMICS SLM 480 V

The characteristic curves are only valid for optimized converter setting data

7.2 Technical data and characteristic curves

Table 7-23 1FT7102-□AC7

Technical data	Code	Unit	Value		
Engineering data					
Rated speed	n_N	RPM	2000		
Number of poles	2p	---	10		
Rated torque (100K)	$M_{N(100K)}$	Nm	24		
Rated current	I_r	A	10		
Static torque (60 K)	$M_{0(60K)}$	Nm	25		
Static torque (100 K)	$M_{0(100K)}$	Nm	30		
Stall current (60 K)	$I_{0(60K)}$	A	10,5		
Stall current (100 K)	$I_{0(100K)}$	A	12,5		
Moment of inertia (with brake)	J_{MotBr}	10^{-4} kgm ²	119		
Moment of inertia (without brake)	J_{mot}	10^{-4} kgm ²	91,4		
Optimum operating point					
Optimum speed	n_{opt}	RPM	2000		
Optimum power	P_{opt}	kW	5,03		
Limiting data					
Max. permissible speed (mech.)	$n_{max\ mech.}$	RPM	6000		
Max. permissible speed (inverter)	$n_{max\ inv}$	RPM	3800		
Max. torque	M_{max}	Nm	120		
Maximum current	I_{max}	A	64		
Physical constants					
Torque constant	k_T	Nm/A	2,40		
Voltage constant	k_E	V/1000 RPM	152		
Winding resistance at 20° C	$R_{ph.}$	Ω	0,3		
Rotating field inductance	L_D	mH	6,2		
Electrical time constant	T_{el}	ms	21		
Mechanical time constant	T_{mech}	ms	1,4		
Thermal time constant	T_{th}	min	70		
Shaft torsional stiffness	C_t	Nm/rad	124000		
Weight with brake	m_{MotBr}	kg	32,3		
Weight without brake	m_{Mot}	kg	26,1		
Recommended Motor Module 6SL312□-□TE21-8AA□					
Rated inverter current	$I_{N\ Inv}$	A	18		
Maximum inverter current	$I_{max\ Inv}$	A	36		
Max. torque at $I_{max\ Inv}$	$M_{max\ Inv}$	Nm	74		

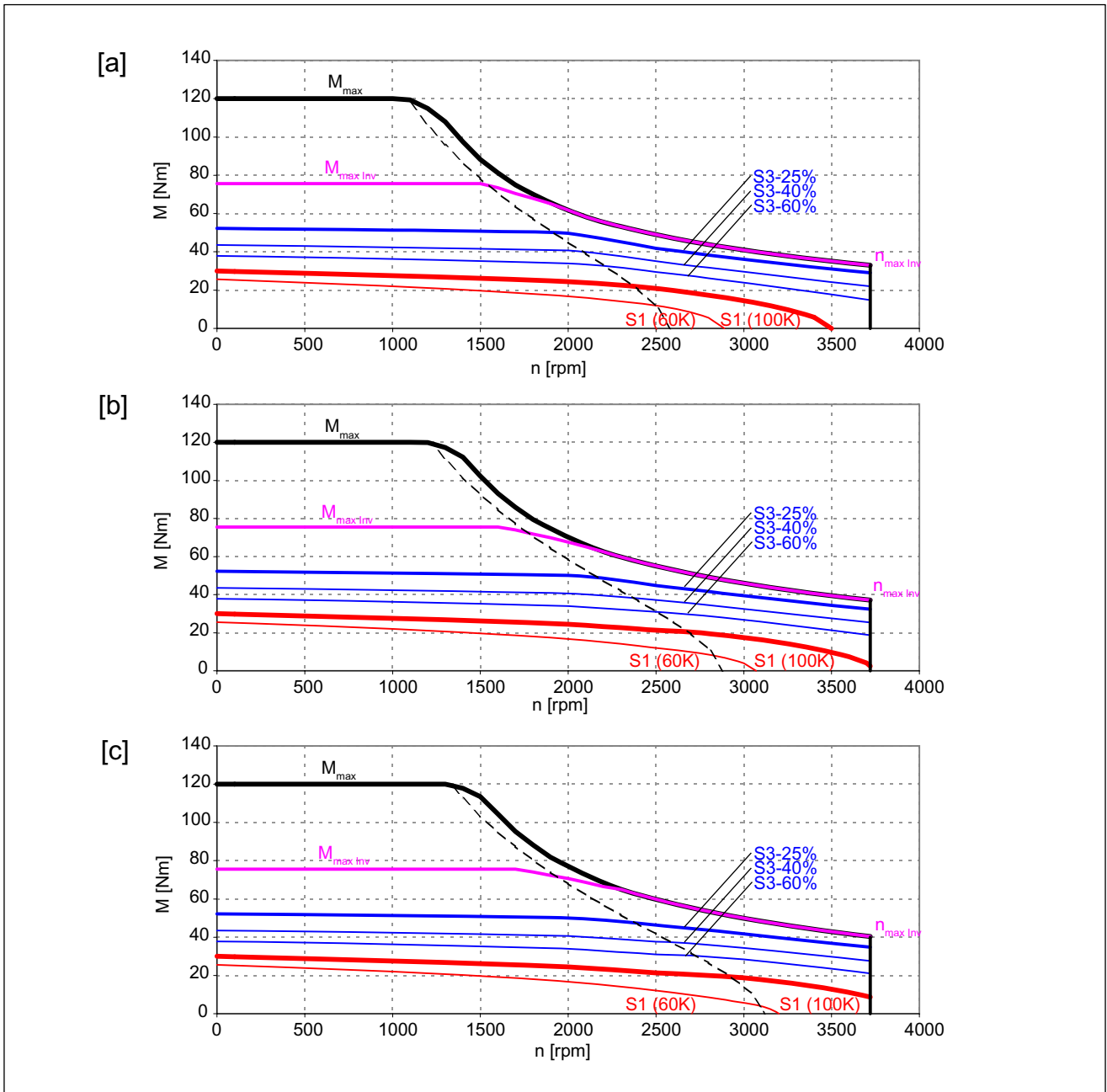

Figure 7-23 1FT7102-□AC7

- [a] SINAMICS SLM 400 V
- [b] SINAMICS ALM 400 V
- [c] SINAMICS SLM 480 V

The characteristic curves are only valid for optimized converter setting data

7.2 Technical data and characteristic curves

Table 7-24 1FT7102-□AF7

Technical data	Code	Unit	Value		
Engineering data					
Rated speed	n_N	RPM	3000		
Number of poles	2p	---	10		
Rated torque (100K)	$M_{N(100K)}$	Nm	20		
Rated current	I_r	A	12		
Static torque (60 K)	$M_{0(60K)}$	Nm	25		
Static torque (100 K)	$M_{0(100K)}$	Nm	30		
Stall current (60 K)	$I_{0(60K)}$	A	15		
Stall current (100 K)	$I_{0(100K)}$	A	18		
Moment of inertia (with brake)	J_{MotBr}	10^{-4} kgm ²	119		
Moment of inertia (without brake)	J_{mot}	10^{-4} kgm ²	91,4		
Optimum operating point					
Optimum speed	n_{opt}	RPM	3000		
Optimum power	P_{opt}	kW	6,28		
Limiting data					
Max. permissible speed (mech.)	$n_{max\ mech.}$	RPM	6000		
Max. permissible speed (inverter)	$n_{max\ inv}$	RPM	5360		
Max. torque	M_{max}	Nm	120		
Maximum current	I_{max}	A	90		
Physical constants					
Torque constant	k_T	Nm/A	1,67		
Voltage constant	k_E	V/1000 RPM	108		
Winding resistance at 20° C	$R_{ph.}$	Ω	0,15		
Rotating field inductance	L_D	mH	3,1		
Electrical time constant	T_{el}	ms	21		
Mechanical time constant	T_{mech}	ms	1,5		
Thermal time constant	T_{th}	min	70		
Shaft torsional stiffness	C_t	Nm/rad	124000		
Weight with brake	m_{MotBr}	kg	32,3		
Weight without brake	m_{Mot}	kg	26,1		
Recommended Motor Module 6SL312□-□TE21-8AA□					
Rated inverter current	$I_{N\ Inv}$	A	18		
Maximum inverter current	$I_{max\ Inv}$	A	36		
Max. torque at $I_{max\ Inv}$	$M_{max\ Inv}$	Nm	56		

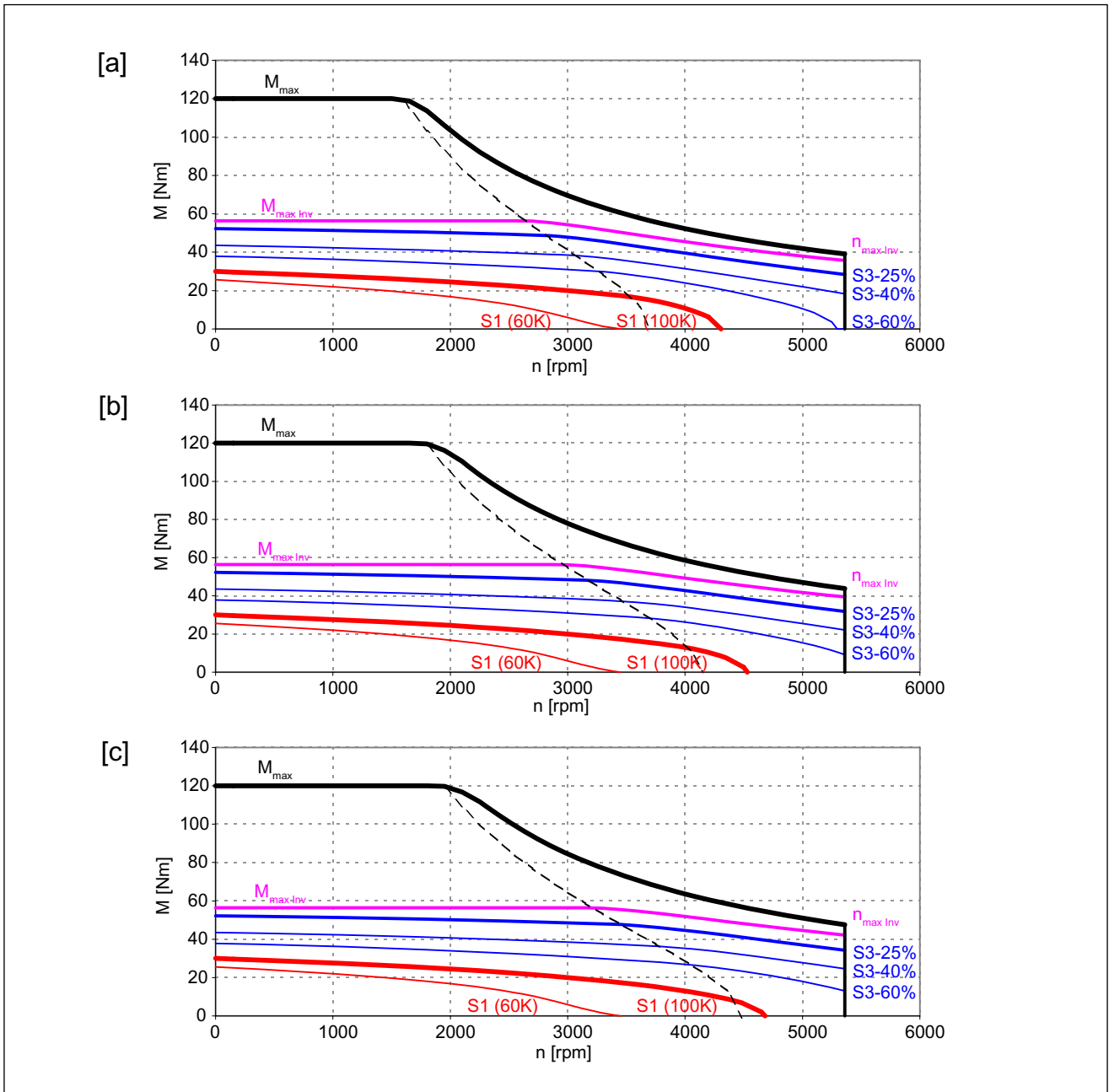

Figure 7-24 1FT7102-□AF7

- [a] SINAMICS SLM 400 V
- [b] SINAMICS ALM 400 V
- [c] SINAMICS SLM 480 V

The characteristic curves are only valid for optimized converter setting data

7.2 Technical data and characteristic curves

Table 7-25 1FT7105-□AB7

Technical data	Code	Unit	Value		
Engineering data					
Rated speed	n_N	RPM	1500		
Number of poles	$2p$	---	10		
Rated torque (100K)	$M_{N(100K)}$	Nm	42		
Rated current	I_r	A	13		
Static torque (60 K)	$M_{0(60K)}$	Nm	41		
Static torque (100 K)	$M_{0(100K)}$	Nm	50		
Stall current (60 K)	$I_{0(60K)}$	A	12		
Stall current (100 K)	$I_{0(100K)}$	A	15		
Moment of inertia (with brake)	J_{MotBr}	10^{-4} kgm ²	206		
Moment of inertia (without brake)	J_{mot}	10^{-4} kgm ²	178		
Optimum operating point					
Optimum speed	n_{opt}	RPM	1500		
Optimum power	P_{opt}	kW	6,60		
Limiting data					
Max. permissible speed (mech.)	$n_{max\ mech.}$	RPM	6000		
Max. permissible speed (inverter)	$n_{max\ inv}$	RPM	2670		
Max. torque	M_{max}	Nm	200		
Maximum current	I_{max}	A	67		
Physical constants					
Torque constant	k_T	Nm/A	3,33		
Voltage constant	k_E	V/1000 RPM	217		
Winding resistance at 20° C	$R_{ph.}$	Ω	0,25		
Rotating field inductance	L_D	mH	6,8		
Electrical time constant	T_{el}	ms	27		
Mechanical time constant	T_{mech}	ms	1,2		
Thermal time constant	T_{th}	min	80		
Shaft torsional stiffness	C_t	Nm/rad	107000		
Weight with brake	m_{MotBr}	kg	50,4		
Weight without brake	m_{Mot}	kg	44,2		
Recommended Motor Module 6SL312□-□TE21-8AA□					
Rated inverter current	$I_{N\ Inv}$	A	18		
Maximum inverter current	$I_{max\ Inv}$	A	36		
Max. torque at $I_{max\ Inv}$	$M_{max\ Inv}$	Nm	112		

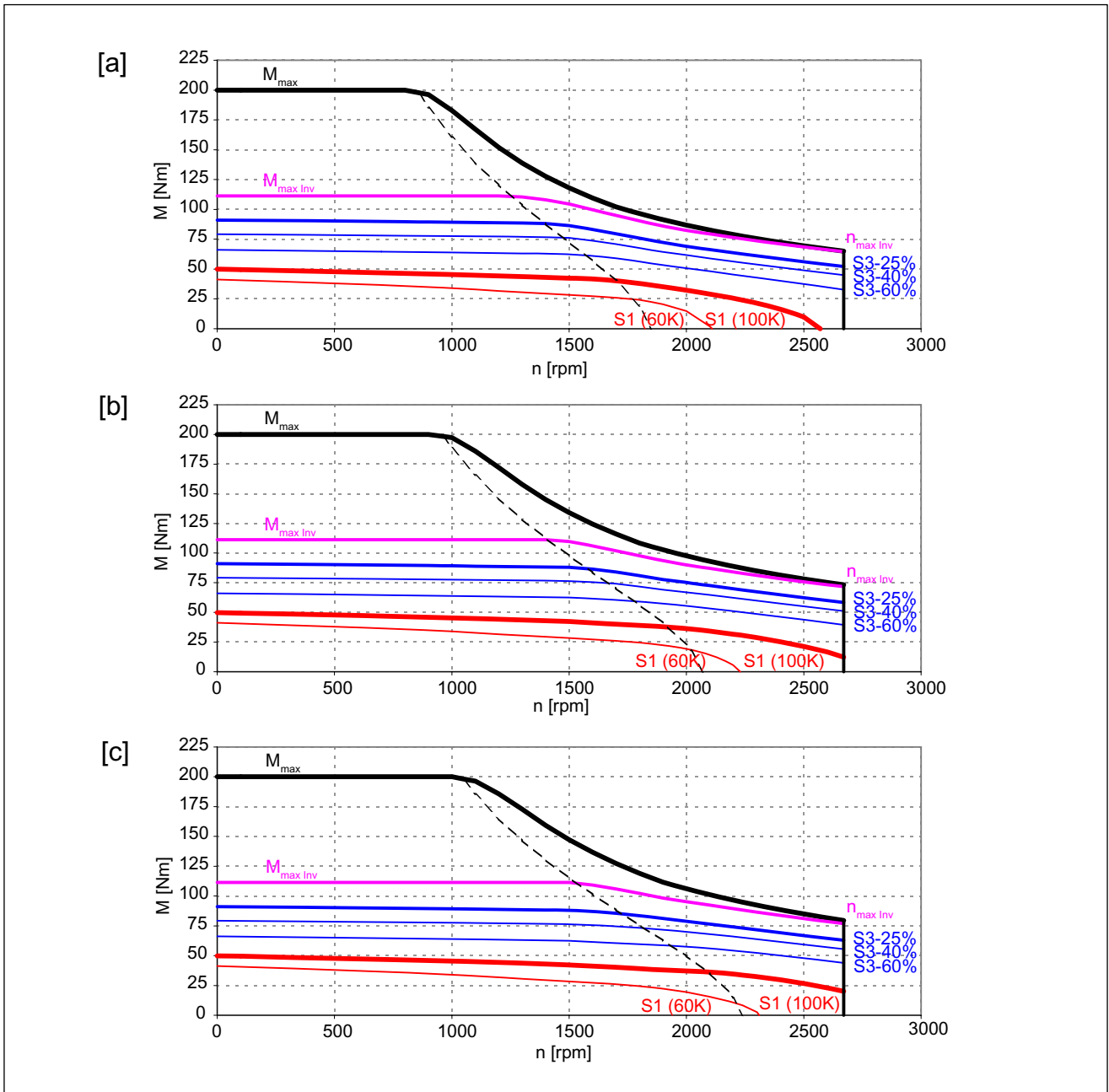

Figure 7-25 1FT7105-□AB7

- [a] SINAMICS SLM 400 V
- [b] SINAMICS ALM 400 V
- [c] SINAMICS SLM 480 V

The characteristic curves are only valid for optimized converter setting data

7.2 Technical data and characteristic curves

Table 7-26 1FT7105-□AC7

Technical data	Code	Unit	Value		
Engineering data					
Rated speed	n_N	RPM	2000		
Number of poles	2p	---	10		
Rated torque (100K)	$M_{N(100K)}$	Nm	38		
Rated current	I_r	A	15		
Static torque (60 K)	$M_{0(60K)}$	Nm	41		
Static torque (100 K)	$M_{0(100K)}$	Nm	50		
Stall current (60 K)	$I_{0(60K)}$	A	15		
Stall current (100 K)	$I_{0(100K)}$	A	18		
Moment of inertia (with brake)	J_{MotBr}	10^{-4} kgm ²	206		
Moment of inertia (without brake)	J_{mot}	10^{-4} kgm ²	178		
Optimum operating point					
Optimum speed	n_{opt}	RPM	2000		
Optimum power	P_{opt}	kW	7,96		
Limiting data					
Max. permissible speed (mech.)	$n_{max\ mech.}$	RPM	6000		
Max. permissible speed (inverter)	$n_{max\ inv}$	RPM	3350		
Max. torque	M_{max}	Nm	200		
Maximum current	I_{max}	A	84		
Physical constants					
Torque constant	k_T	Nm/A	2,78		
Voltage constant	k_E	V/1000 RPM	173		
Winding resistance at 20° C	$R_{ph.}$	Ω	0,15		
Rotating field inductance	L_D	mH	4,3		
Electrical time constant	T_{el}	ms	29		
Mechanical time constant	T_{mech}	ms	1,0		
Thermal time constant	T_{th}	min	80		
Shaft torsional stiffness	C_t	Nm/rad	107000		
Weight with brake	m_{MotBr}	kg	50,4		
Weight without brake	m_{Mot}	kg	44,2		
Recommended Motor Module 6SL312□-□TE21-8AA□					
Rated inverter current	$I_{N\ Inv}$	A	18		
Maximum inverter current	$I_{max\ Inv}$	A	36		
Max. torque at $I_{max\ Inv}$	$M_{max\ Inv}$	Nm	90		

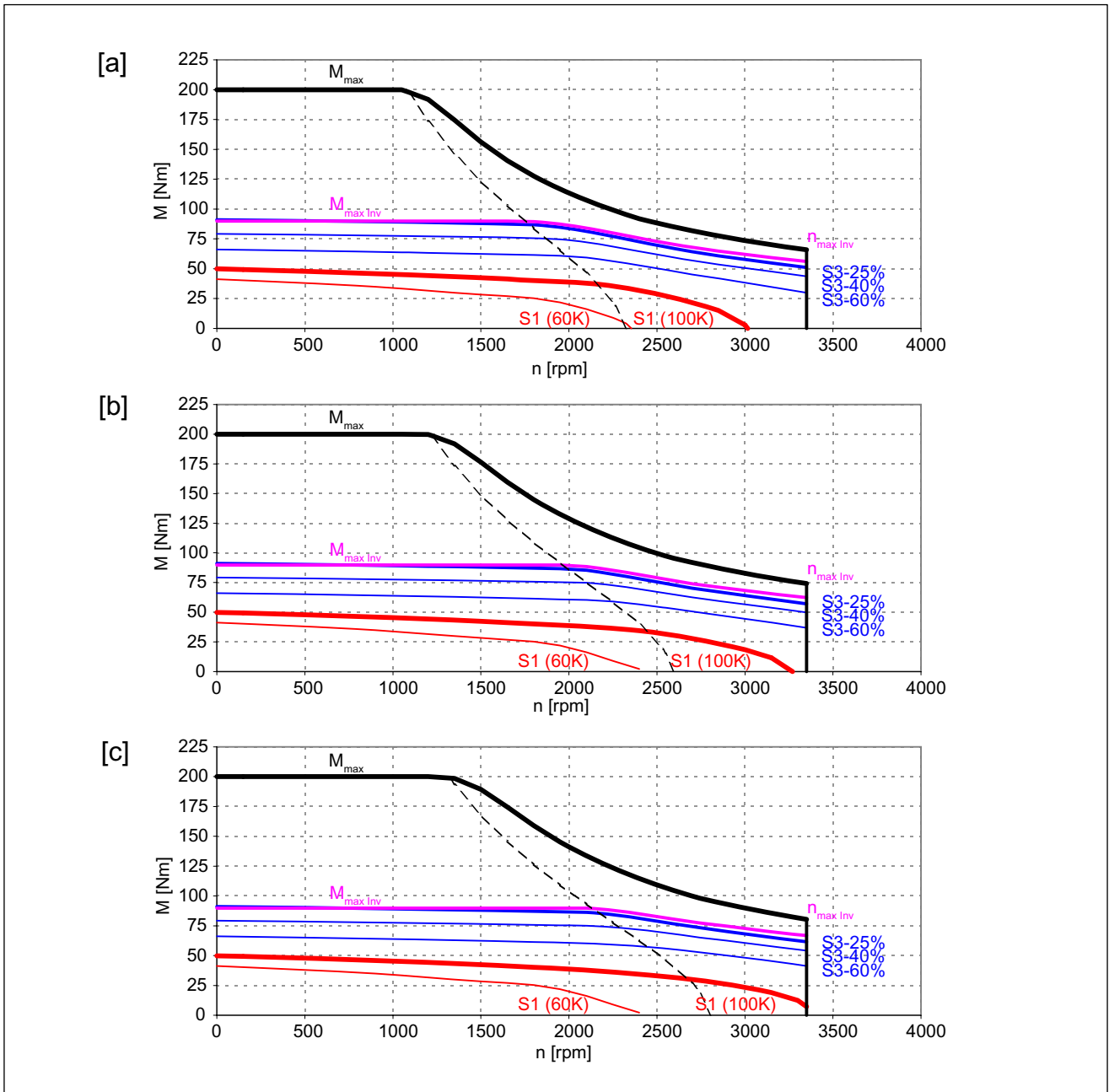

Figure 7-26 1FT7105-□AC7

- [a] SINAMICS SLM 400 V
- [b] SINAMICS ALM 400 V
- [c] SINAMICS SLM 480 V

The characteristic curves are only valid for optimized converter setting data

Technical data and characteristic curves

7.2 Technical data and characteristic curves

Table 7-27 1FT7105-□AF7

Technical data	Code	Unit	Value		
Engineering data					
Rated speed	n_N	RPM	3000		
Number of poles	$2p$	---	10		
Rated torque (100K)	$M_{N(100K)}$	Nm	28		
Rated current	I_r	A	15		
Static torque (60 K)	$M_{0(60K)}$	Nm	41		
Static torque (100 K)	$M_{0(100K)}$	Nm	50		
Stall current (60 K)	$I_{0(60K)}$	A	21		
Stall current (100 K)	$I_{0(100K)}$	A	26		
Moment of inertia (with brake)	J_{MotBr}	10^{-4} kgm ²	206		
Moment of inertia (without brake)	J_{mot}	10^{-4} kgm ²	178		
Optimum operating point					
Optimum speed	n_{opt}	RPM	3000		
Optimum power	P_{opt}	kW	8,8		
Limiting data					
Max. permissible speed (mech.)	$n_{max\ mech.}$	RPM	6000		
Max. permissible speed (inverter)	$n_{max\ inv}$	RPM	4630		
Max. torque	M_{max}	Nm	200		
Maximum current	I_{max}	A	116		
Physical constants					
Torque constant	k_T	Nm/A	1,92		
Voltage constant	k_E	V/1000 RPM	125		
Winding resistance at 20° C	$R_{ph.}$	Ω	0,08		
Rotating field inductance	L_D	mH	2,3		
Electrical time constant	T_{el}	ms	29		
Mechanical time constant	T_{mech}	ms	1,2		
Thermal time constant	T_{th}	min	80		
Shaft torsional stiffness	C_t	Nm/rad	107000		
Weight with brake	m_{MotBr}	kg	50,4		
Weight without brake	m_{Mot}	kg	44,2		
Recommended Motor Module 6SL312□-□TE23-1AA□					
Rated inverter current	$I_{N\ Inv}$	A	30		
Maximum inverter current	$I_{max\ Inv}$	A	56		
Max. torque at $I_{max\ Inv}$	$M_{max\ Inv}$	Nm	102		

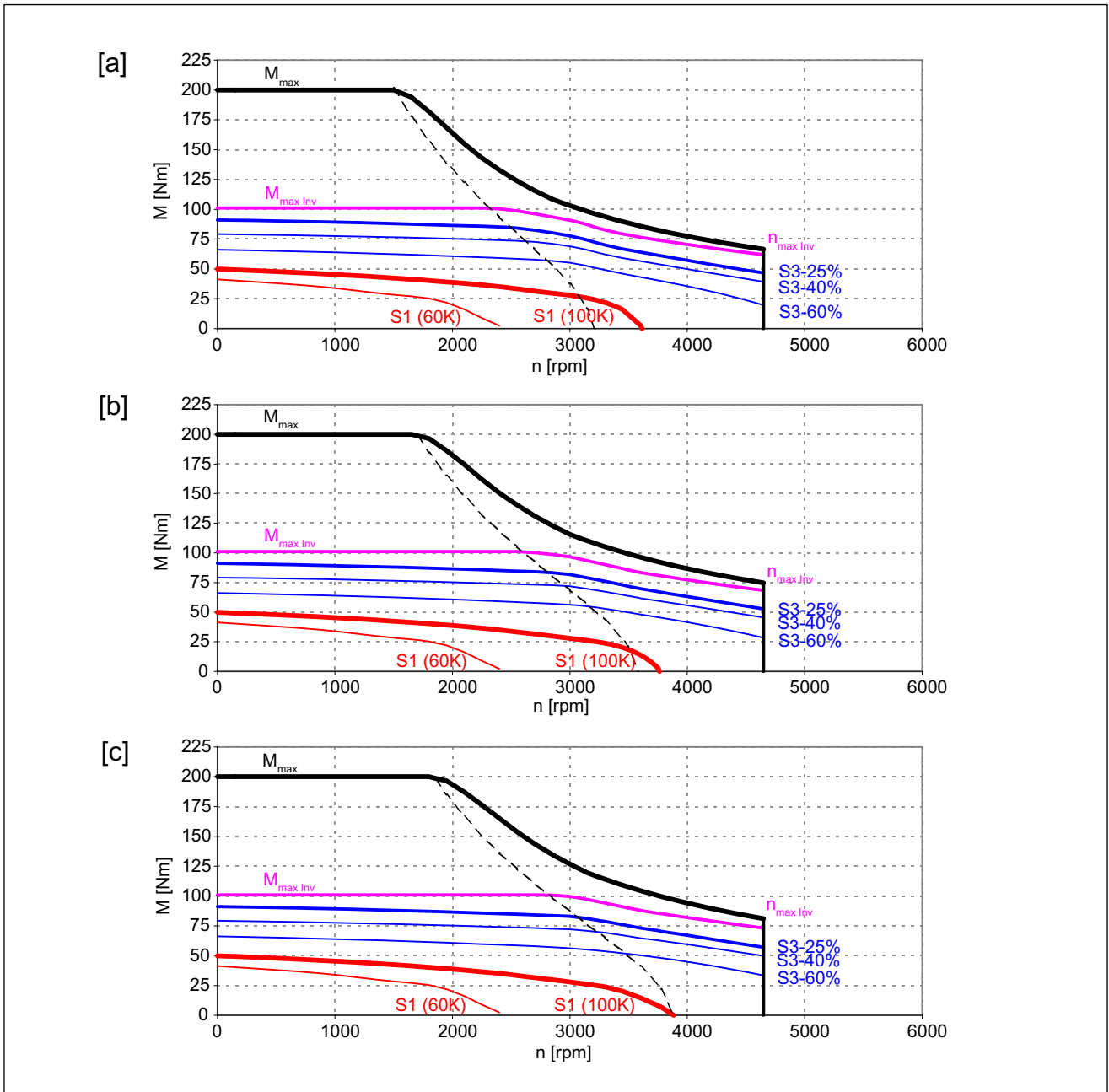

Figure 7-27 1FT7105-□AF7

- [a] SINAMICS SLM 400 V
- [b] SINAMICS ALM 400 V
- [c] SINAMICS SLM 480 V

The characteristic curves are only valid for optimized converter setting data

7.2 Technical data and characteristic curves

Table 7-28 1FT7108-□AB7

Technical data	Code	Unit	Value		
Engineering data					
Rated speed	n_N	RPM	1500		
Number of poles	2p	---	10		
Rated torque (100K)	$M_{N(100K)}$	Nm	61		
Rated current	I_r	A	16		
Static torque (60 K)	$M_{0(60K)}$	Nm	58		
Static torque (100 K)	$M_{0(100K)}$	Nm	70		
Stall current (60 K)	$I_{0(60K)}$	A	15		
Stall current (100 K)	$I_{0(100K)}$	A	18		
Moment of inertia (with brake)	J_{MotBr}	10^{-4} kgm ²	276		
Moment of inertia (without brake)	J_{mot}	10^{-4} kgm ²	248		
Optimum operating point					
Optimum speed	n_{opt}	RPM	1500		
Optimum power	P_{opt}	kW	9,58		
Limiting data					
Max. permissible speed (mech.)	$n_{max\ mech.}$	RPM	6000		
Max. permissible speed (inverter)	$n_{max\ inv}$	RPM	2390		
Max. torque	M_{max}	Nm	280		
Maximum current	I_{max}	A	87		
Physical constants					
Torque constant	k_T	Nm/A	3,89		
Voltage constant	k_E	V/1000 RPM	242		
Winding resistance at 20° C	$R_{ph.}$	Ω	0,2		
Rotating field inductance	L_D	mH	6		
Electrical time constant	T_{el}	ms	30		
Mechanical time constant	T_{mech}	ms	1,0		
Thermal time constant	T_{th}	min	95		
Shaft torsional stiffness	C_t	Nm/rad	95700		
Weight with brake	m_{MotBr}	kg	65,1		
Weight without brake	m_{Mot}	kg	59		
Recommended Motor Module 6SL312□-□TE21-8AA□					
Rated inverter current	$I_{N\ Inv}$	A	18		
Maximum inverter current	$I_{max\ Inv}$	A	36		
Max. torque at $I_{max\ Inv}$	$M_{max\ Inv}$	Nm	134		

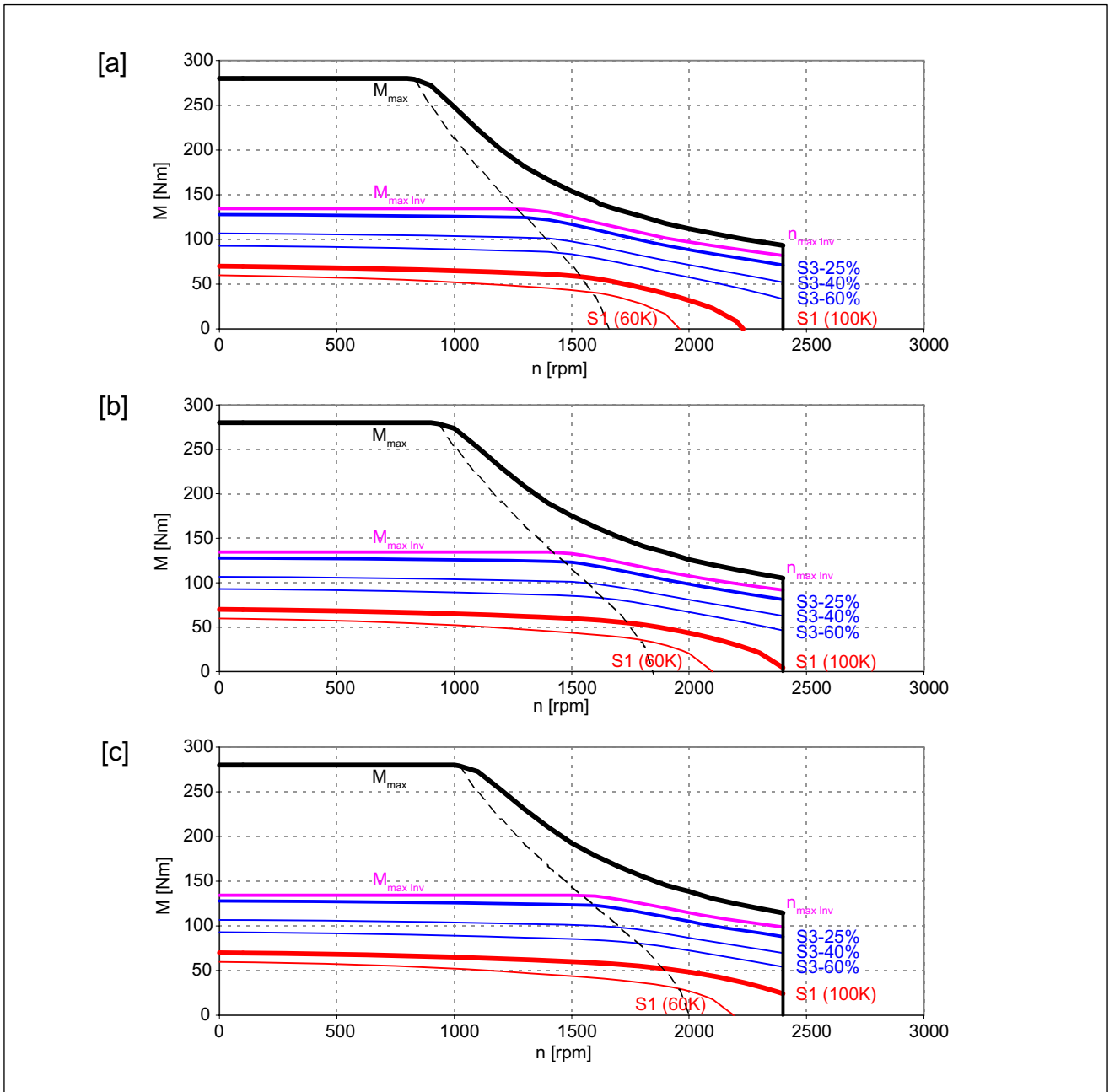

Figure 7-28 1FT7108-□AB7

- [a] SINAMICS SLM 400 V
- [b] SINAMICS ALM 400 V
- [c] SINAMICS SLM 480 V

The characteristic curves are only valid for optimized converter setting data

7.2 Technical data and characteristic curves

Table 7-29 1FT7108-□AC7

Technical data	Code	Unit	Value		
Engineering data					
Rated speed	n_N	RPM	2000		
Number of poles	2p	---	10		
Rated torque (100K)	$M_{N(100K)}$	Nm	50		
Rated current	I_r	A	18		
Static torque (60 K)	$M_{0(60K)}$	Nm	58		
Static torque (100 K)	$M_{0(100K)}$	Nm	70		
Stall current (60 K)	$I_{0(60K)}$	A	21		
Stall current (100 K)	$I_{0(100K)}$	A	25		
Moment of inertia (with brake)	J_{MotBr}	10^{-4} kgm ²	276		
Moment of inertia (without brake)	J_{mot}	10^{-4} kgm ²	248		
Optimum operating point					
Optimum speed	n_{opt}	RPM	2000		
Optimum power	P_{opt}	kW	10,5		
Limiting data					
Max. permissible speed (mech.)	$n_{max\ mech.}$	RPM	6000		
Max. permissible speed (inverter)	$n_{max\ inv}$	RPM	3310		
Max. torque	M_{max}	Nm	280		
Maximum current	I_{max}	A	120		
Physical constants					
Torque constant	k_T	Nm/A	2,80		
Voltage constant	k_E	V/1000 RPM	175		
Winding resistance at 20° C	$R_{ph.}$	Ω	0,11		
Rotating field inductance	L_D	mH	3,1		
Electrical time constant	T_{el}	ms	28		
Mechanical time constant	T_{mech}	ms	1,0		
Thermal time constant	T_{th}	min	95		
Shaft torsional stiffness	C_t	Nm/rad	95700		
Weight with brake	m_{MotBr}	kg	65,1		
Weight without brake	m_{Mot}	kg	59		
Recommended Motor Module 6SL312□-□TE23-1AA□					
Rated inverter current	$I_{N\ Inv}$	A	30		
Maximum inverter current	$I_{max\ Inv}$	A	56		
Max. torque at $I_{max\ Inv}$	$M_{max\ Inv}$	Nm	149		

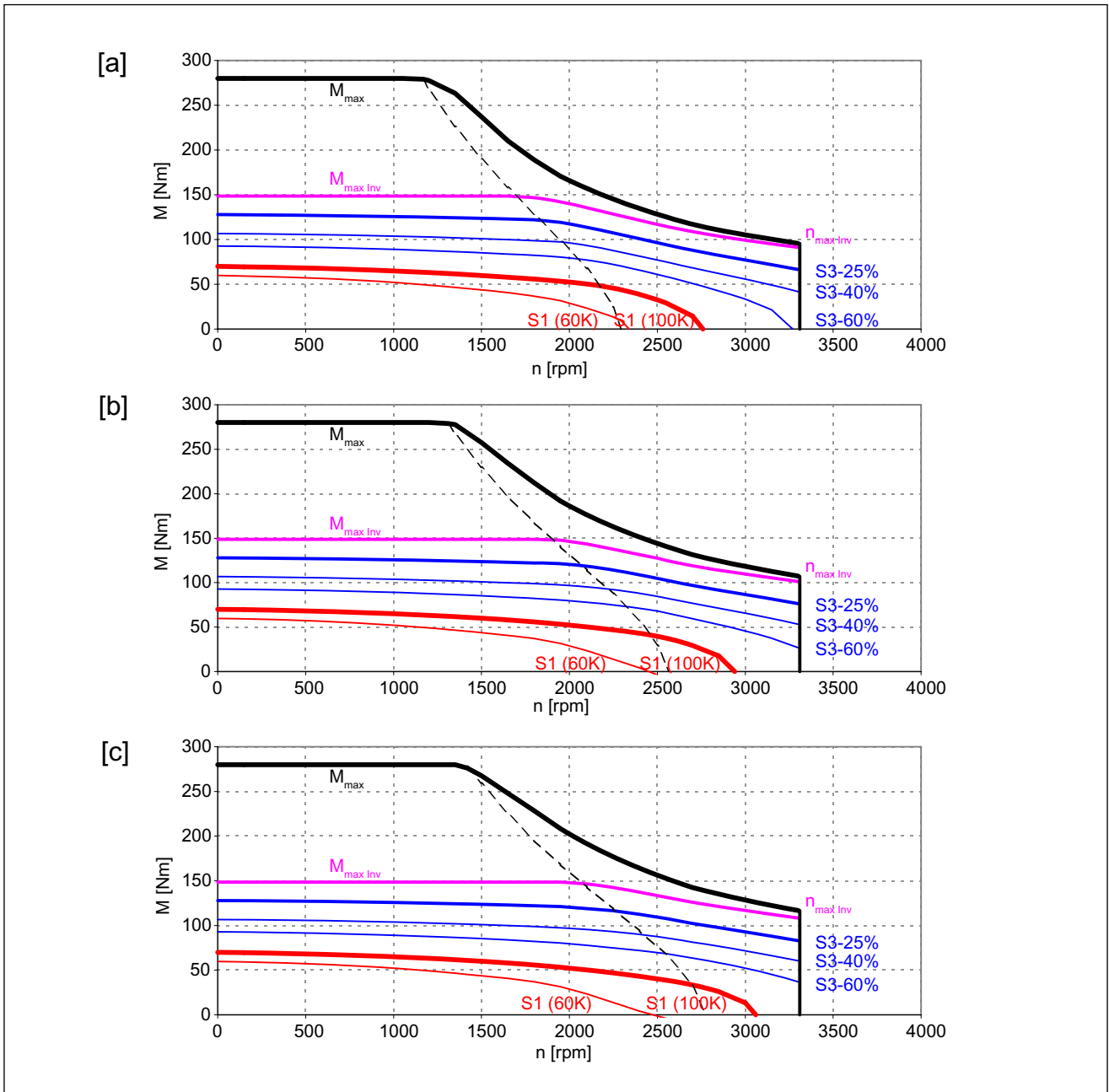

Figure 7-29 1FT7108-□AC7

- [a] SINAMICS SLM 400 V
- [b] SINAMICS ALM 400 V
- [c] SINAMICS SLM 480 V

The characteristic curves are only valid for optimized converter setting data

Dimension drawings

CAD CREATOR

The CAD CREATOR provides a user-friendly interface which helps you to find product-specific data quickly and supports you in generating plant documentation containing project-specific information.

Benefits

- Multilingual operator interface in English, French, German, Italian and Spanish included
- Dimension sheets with measurements in mm or inches
- Dimension sheets and 2D/3D CAD data for
 - 1FT7 Compact / 1FT6 / 1FK7 synchronous motors
 - 1PH7/1PH4/1PM4/1PM6 asynchronous motors
 - 1FT6/1FK7/1FK7-DYA geared motors
 - 1FW3 torque motors
 - 1FE1 built-in motors

The CAD CREATOR provides you with various options to begin with product configuration:

- Order number
- Order number search
- Geometric data

Once a product is successfully configured, the product-specific information, such as dimension drawing and 2D/3D CAD data are displayed and made available for storing in various formats, e.g.: *.pdf, *.dxf, *.stp oder *.igs.

The CAD CREATOR is available on CD-ROM and as an Internet application.

Additional information is available in the Internet under:

<http://www.siemens.com/cad-creator>

How up-to-date are the dimension drawings

Note

Siemens AG reserves the right to change the dimensions of the motors as part of mechanical design improvements without prior notice. This means that dimensions drawings can go out-of-date. Up-to-date dimension drawings can be requested at no charge from your local SIEMENS representative.

For motor		Dimensions in mm (in)										Flange 1 (FT6-compatible)				
Shaft height	Type	DIN IEC	a ₁ P	b ₁ N	c ₁ LA	e ₁ M	f AB	f ₁ T	g ₂	o ₁	s ₂ S	i ₂	without brake		with brake	
													k LB	o	k LB	o
1FT7, type IM B5, natural cooling, with connector, with/without brake																
80	1FT7082		195 (7.68)	130 (5.12)	11.5 (0.45)	165 (6.50)	155 (6.10)	3.5 (0.14)	141 (5.55)	50 (1.97)	11 (0.43)	58 (2.28)	196 (7.72)	130 (5.12)	248 (9.76)	183 (7.20)
	1FT7084												247 (9.72)	165 (6.50)	299 (11.77)	234 (9.21)
	1FT7086													299 (11.77)	234 (9.21)	351 (13.82)
100	1FT7102		245 (9.65)	180 (7.09)	13 (0.51)	215 (8.46)	196 (7.72)	4 (0.16)	161 (6.34)	55 (2.17)	14 (0.55)	80 (3.15)	221 (8.70)	151 (5.94)	273 (10.75)	203 (7.99)
	1FT7105												307 (12.09)	238 (9.37)	360 (14.17)	290 (11.42)
	1FT7108													377 (14.84)	307 (12.09)	429 (16.89)

		Flange 0			without brake		with brake		Drive end shaft extension					
Shaft height	Type	DIN IEC	b ₂	i ₂	f ₂	k LB	o	k LB	o	d D	d ₆	l E	t GA	u F
80	1FT7082		66 (2.60)	64.5 (2.54)	6 (0.24)	189 (7.44)	124 (4.88)	241 (9.49)	177 (6.97)	32 (1.26)	M12	58 (2.28)	35 (1.38)	10 (0.39)
	1FT7084					241 (9.49)	159 (6.26)	293 (11.54)	228 (8.98)					
	1FT7086					292 (11.50)	228 (8.98)	345 (13.58)	280 (11.02)					
100	1FT7102		81 (3.19)	87 (3.43)	6.5 (0.26)	214 (8.43)	144 (5.67)	266 (10.47)	196 (7.72)	38 (1.50)	M12	80 (3.15)	41 (1.61)	10 (0.39)
	1FT7105					301 (11.85)	231 (9.09)	353 (13.90)	283 (11.14)					
	1FT7108					370 (14.57)	300 (11.81)	422 (16.61)	352 (13.86)					

Flange 0
1FT708 .
1FT710 .

Flange 1
(1FT6-compatible)
1FT708 .
1FT710 .

Figure 8-2 1FT7 Compact synchronous motors, AH 80 and 100

Appendix

A.1 References

An overview of publications that is updated monthly is provided in a number of languages in the Internet at:

<<http://www.siemens.com/motioncontrol>>
through "Support", "Technical Documentation", "Documentation Overview"

General Documentation

/D 21.1/	SINAMICS S120 Catalog Built-in converter units 0.12 kW to 1200 kW
/NC 60/	SINUMERIK and SIMODRIVE Catalog Automation Systems for Machine Tools
/NC 61/	SINUMERIK and SINAMICS Catalog Automation Systems for Machine Tools
/DA65.3/	SIMOVERT MASTERDRIVES Catalog Synchronous and Induction Motors for SIMOVERT MASTERDRIVES

Electronic Documentation

/CD1/	DOC ON CD The SINUMERIK System (includes all SINUMERIK 840D/810D and SIMODRIVE 611D)
/CD2/	DOC ON CD The SINAMICS System

Manufacturer/Service Documentation

/PJAL/	Configuration Manual, Synchronous Motors SIMODRIVE 611, SIMOVERT MASTERDRIVES MC Synchronous Motors General Section
/PFK7S/	Configuration Manual, Synchronous Motors SINAMICS S120 1FK7 Synchronous Motors
/PFT6S/	Configuration Manual, Synchronous Motors SINAMICS S120 1FT6 Synchronous Motors
/PMH2/	Configuration Manual, Hollow-Shaft Measuring System SINAMICS S120, SIMODRIVE 611, SIMOVERT MASTERDRIVES, SIMAG H2 Hollow-Shaft Measuring System
/PFK7/	Configuration Manual, Synchronous Motors SIMODRIVE 611, SIMOVERT MASTERDRIVES 1FK7 Synchronous Motors
/PFT6/	Configuration Manual, Synchronous Motors SIMODRIVE 611, SIMOVERT MASTERDRIVES 1FT6 Synchronous Motors
/PFK6/	Configuration Manual, Synchronous Motors SIMODRIVE 611, SIMOVERT MASTERDRIVES 1FK6 Synchronous Motors
/PFS6/	Configuration Manual, Synchronous Motors SIMOVERT MASTERDRIVES 1FS6 Synchronous Motors, Explosion-Protected

/PFU/	Configuration Manual, Synchronous Motors SINAMICS S120, SIMOVERT MASTERDRIVES, MICROMASTER SIEMOSYN Synchronous Motors 1FU8
/ASAL/	Configuration Manual, Induction Motors SIMODRIVE 611, SIMOVERT MASTERDRIVES Induction Motors General Section
/APH2/	Configuration Manual, Asynchronous Motors SIMODRIVE 611 1PH2 Induction Motors
/APH4/	Configuration Manual, Asynchronous Motors SIMODRIVE 611 1PH4 Induction Motors
/APH7/	Configuration Manual, Asynchronous Motors SIMODRIVE 611 1PH7 Induction Motors
/PPM/	Configuration Manual, Hollow-Shaft Motors SIMODRIVE 611 Hollow Shaft Motors for Main Spindle Drives 1PM6 and 1PM4
/PJFE/	Configuration Manual, Synchronous Build-in Motors SIMODRIVE 611 Synchronous Motors for Main Spindle Drives 1FE1 Synchronous Build-in Motors
/PJTM/	Configuration Manual, Build-in Torque Motors SIMODRIVE 611 Build-in Torque Motors 1FW6

- /PJLM/ Configuration Manual, Linear Motors**
SIMODRIVE 611
Linear Motors 1FN1 and 1FN3
- /PMS/ Configuration Manual, ECS Motor Spindle**
SIMODRIVE 611
ECS Motor Spindle 2SP1
- /APL6/ Configuration Manual, Asynchronous Motors**
SIMOVERT MASTERDRIVES VC/MC
Induction Motors 1PL6
- /APH7M/ Configuration Manual, Asynchronous Motors**
SIMOVERT MASTERDRIVES VC/MC
Induction Motors 1PH7
- /PKTM/ Configuration Manual, Complete Torque Motors**
SIMOVERT MASTERDRIVES
Complete Torque Motors 1FW3

A.2 Suggestions/corrections

If you come across any misprints in this document, please let us know using this form.
We would also be grateful for any suggestions and recommendations for improvement.

On: SIEMENS AG A&D MC MS1 Postfach 3180 D-91050 Erlangen, Germany Telefax.: +49 (0) 9131 / 98 - 63315 (documentation) mailto:docu.motioncontrol@siemens.com http://www.siemens.com/automation/service&support	From Name:
	Company/dept.
	Street:
	Zip code: Location:
	Telephone: /
	Telefax: /

Suggestions and/or corrections

Index

A

Absolute value encoder, 87
Armature short-circuit braking, 39
Axial force, 39

B

Balancing, 51
Bearing version, 51
Belt pre-tension, 38
Brake resistors, 39

C

CAD CREATOR, 153
Cantilever force, 36
Configuring
 SIZER, 67
 STARTER, 70
Coupling outputs, 44

D

Danger and warning information, 7
Disposal, 7
Drive ES, 72

E

Effects on mounting, 31
Encoders, 85
Engineering System, 72
ESDS instructions, 9

H

Holding brake, 88
Hotline, 6

I

Incremental encoders, 86
Induced vibrations, 35

R

Residual risks, 10
Resistance characteristic, 84

S

Shaft end, 51
SIZER, 67
STARTER, 70

T

Technical data

- 1FT7042-□AF7, 94
- 1FT7042-□AK7, 96
- 1FT7044-□AF7, 98
- 1FT7044-□AK7, 100
- 1FT7046-□AF7, 102
- 1FT7046-□AH7, 104
- 1FT7062-□AF7, 106
- 1FT7062-□AK7, 108
- 1FT7064-□AF7, 110
- 1FT7064-□AK7, 112
- 1FT7066-□AF7, 114
- 1FT7066-□AH7, 116
- 1FT7068-□AF7, 118
- 1FT7082-□AC7, 120
- 1FT7082-□AF7, 122
- 1FT7082-□AH7, 124
- 1FT7084-□AC7, 126
- 1FT7084-□AF7, 128
- 1FT7084-□AH7, 130
- 1FT7086-□AC7, 132
- 1FT7086-□AF7, 134
- 1FT7102-□AB7, 136
- 1FT7102-□AC7, 138
- 1FT7102-□AF7, 140
- 1FT7105-□AB7, 142
- 1FT7105-□AC7, 144
- 1FT7105-□AF7, 146
- 1FT7108-□AB7, 148
- 1FT7108-□AC7, 150

Technical features, 15

Technical Support, 6

Temperature sensor, KTY 84, 83

Thermal motor protection, 83

Third-party products, 9

Torque characteristics, 54

V

Vibration severity grade, 51

W

Winding temperature rise, 53

6SN1 197-0AD13-0APO

Siemens AG

**Automation and Drives
Motion Control Systems
Postfach 3180
91050 ERLANGEN
GERMANY**

www.siemens.com/motioncontrol