

Agilent 1GC1-8234

0–18 GHz Packaged Active Mixer

TC230P
Data Sheet

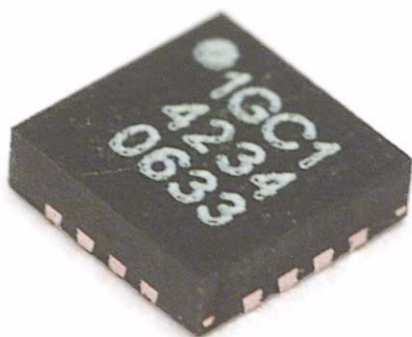

Features

- DC-18 GHz on RF and LO
- DC-1 GHz IF
- Low Conversion Loss:
4 dB typ
- High Input P_{-1dB} :
+9 dBm @ 10 GHz
+2 dBm @ 20 GHz
- Single-Supply Operation
 $V_{Supply} = -7 V$
- QFN SMT Package

Package Type:	3 x 3 mm MLF-16/QFN-16
Package Dimensions:	3 x 3 mm (118 x 118 mils)
Package Thickness:	0.90 mm (35 mils)
Pad (lead) Pitch:	0.5 mm (20 mils)
Pad (lead) Width:	0.25 mm (10 mils)

Description

The TC230P offers substantially improved frequency range and improved broadband performance in a Gilbert-cell mixer. It enables low-cost topologies for both RF and low-microwave instrumentation, which need best-available performance, cost, and manufacturability.

The TC230 can be utilized as a fundamental, 3rd, 5th, or 7th order harmonic mixer. The mixer is fabricated using WPTC's HBT process, which provides excellent process uniformity, reliability, and 1/f noise performance.

The TC230P is packaged in a 3x3mm plastic molded QFN package.

Absolute Maximum Ratings^[1]

Symbol	Parameters/Conditions	Min.	Max.	Units
V_{EE}	Emitter Voltage	-7.5	-6.5	Volts
P_{in-RF}	CW Input Power - RF port		+10	dBm
P_{in-LO}	CW Input Power - LO port	-55	+10	dBm
T_{ch}	Operating Channel Temperature ^[2]		150	°C
T_{case}	Operating Case Temperature	-55		°C
T_{stg}	Storage Temperature	-65	165	°C
T_{max}	Maximum Assembly Temperature (60 seconds maximum)		300	°C

Notes:

^[1] Operatin in excess of any one of these conditions may result in permanent damage to this device. $T_A = 25\text{ }^\circ\text{C}$ except for T_{ch} , T_{stg} , and T_{max} .

^[2] Refer to DC Specifications / Physical Properties table for derating information.

DC Specifications/Physical Properties ^[1]

Symbol	Parameters/Conditions	Min.	Typ.	Max.	Units
V _{EE}	Emitter Voltage		-7		Volts
I _{EE}	Emitter Current	-100	-95	-90	mA

^[1] Measured on Wafer with T_{chuck} = 25°C unless otherwise noted.

[

RF Specifications^[1]

Symbol	Parameters/Conditions	Min.	Typ. 0-8	Typ. 0-18	Max.	Units
BW-LO	LO Bandwidth	0			20	GHz
BW-RF	RF Bandwidth	0			20	GHz
BW-IF	IF Bandwidth	0			1	GHz
P _{comp}	Power Compression at 0 dBm Input		.1	.5	.9	dB
CE	Conversion Efficiency	-1	-4	-4	-8	dB
IP _{-1dB}	Input 1 dB Power Compression		9	2		dBm
NF	Noise Figure		24	25		dB
L-R	LO to RF Isolation		35	35		dB
R-L	RF to LO Isolation			35		dB
L-I	Lo to IF Isolation			25		dB
R-I	RF to IF Isolation			25		dB
RL RF	RF Port Return Loss		18	11		dB
RL LO	LO Port Return Loss		15	10		dB
RL IF	IF Port Return Loss		14	10		dB

Notes:

1. Measured on wafer with T_{chuck} = 25°C with V_{EE} = -7V and P_{LO} = -5 dBm. Numbers given are worst-case across the band unless otherwise noted.

Applications

The TC230 is ideal for down-converting 0-20 GHz signals to an IF of 0-1 GHz. The TC230 is particularly well suited for applications that require load-insensitive conversion loss, good spurious signal suppression, reasonable dynamic range, and low LO power over a wide bandwidth.

Biasing

The TC230 requires a single -7 V power supply to V_{EE} . Current will be approximately 95 mA.

Operation

The TC230 does not require capacitors on any ports other than V_{EE} . It is capable of operation (including pass-through operation) without connecting RFbar and LObar.

LO power can vary between -10 and 0 dBm.

Pass-through mode is available with LObar held at a non-zero voltage - see the Pass-Thru Mode S-Parameter plot. For increased gain (S21b), hold LObar positive; for decreased gain (S21a), hold LObar negative.

Recommended pass-thru LObar voltage is +0.5V, although voltages between +0.4V and +1V are acceptable. These are dissipated through 55 ohms on-chip.

This package is compatible with wave-solder or reflow printed circuit board soldering processes.

Assembly Techniques

GaAs MMICs are ESD sensitive. ESD preventive measures must be employed in all aspects of handling, assembly, and storage.

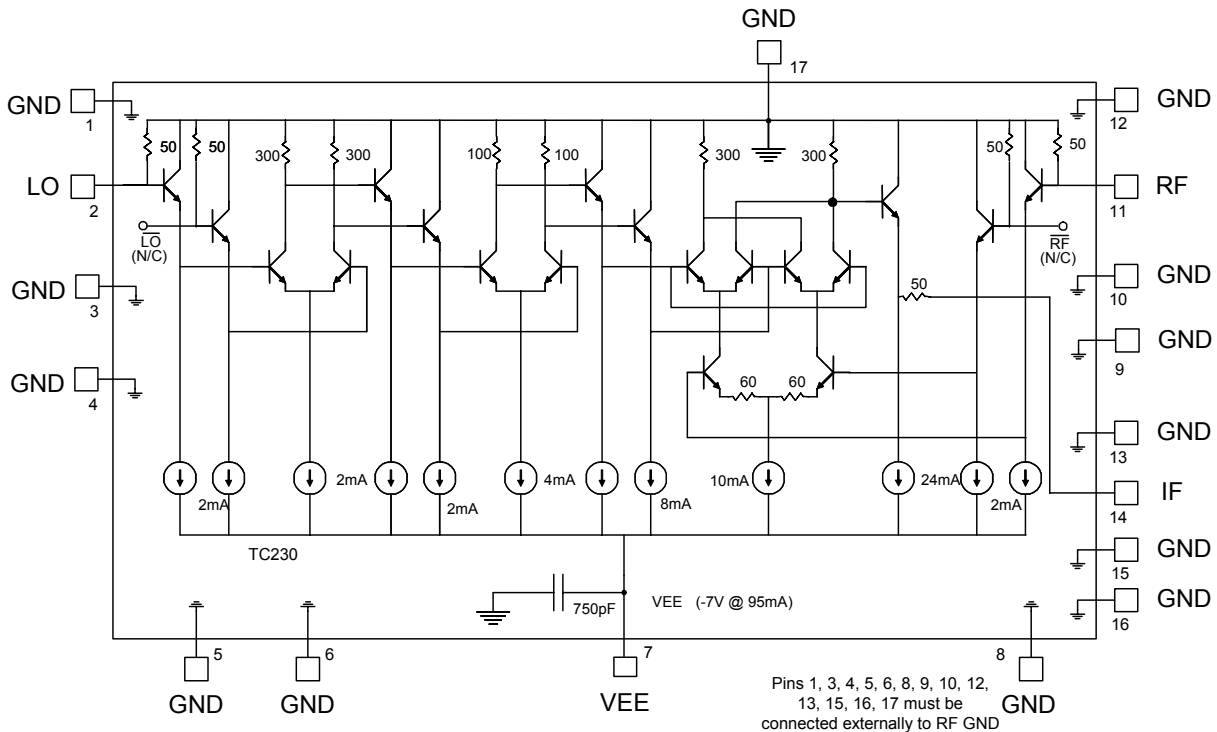

Figure 1.
TC230P Schematic

Top View

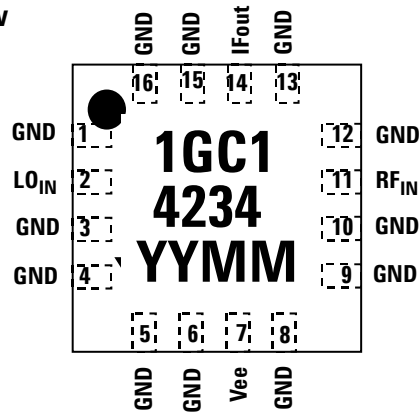

Figure 2.
TC230P Package Pin 3uts - Top View

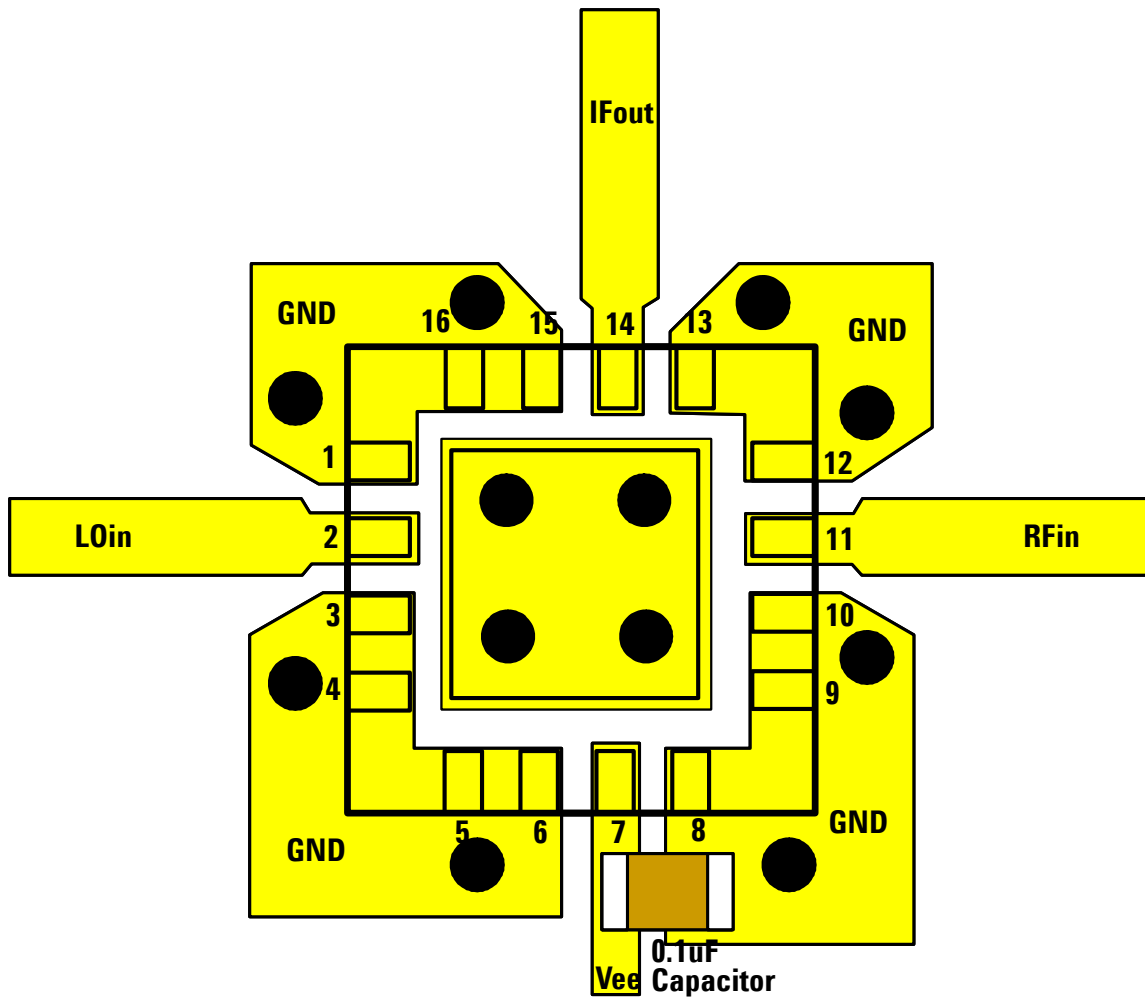

Figure 3.
TC230P Board Configuration

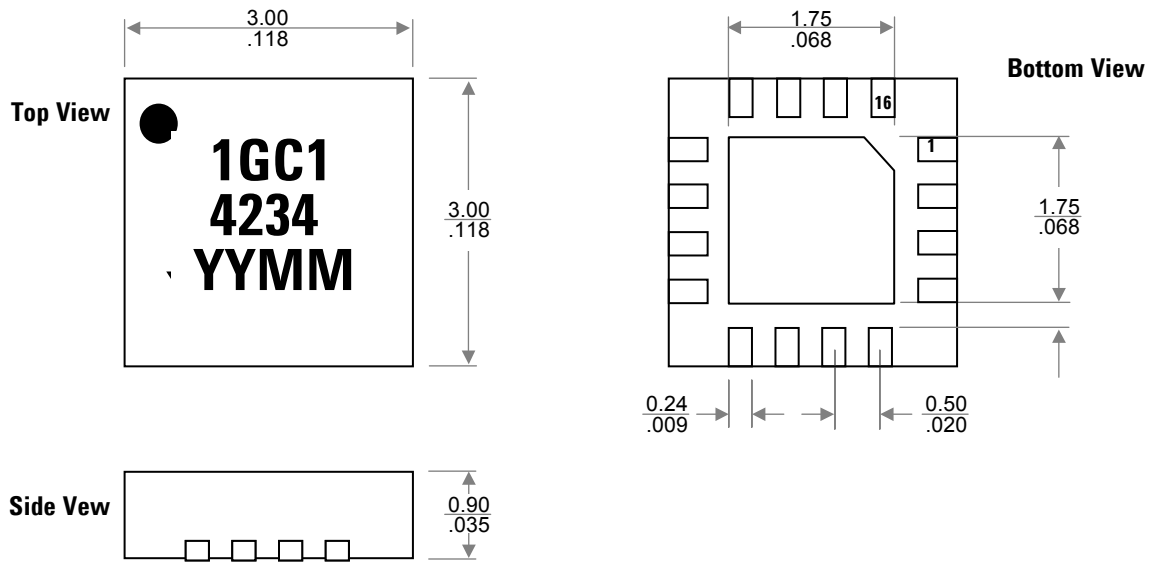

Figure 4.
TC230P Package Dimensions

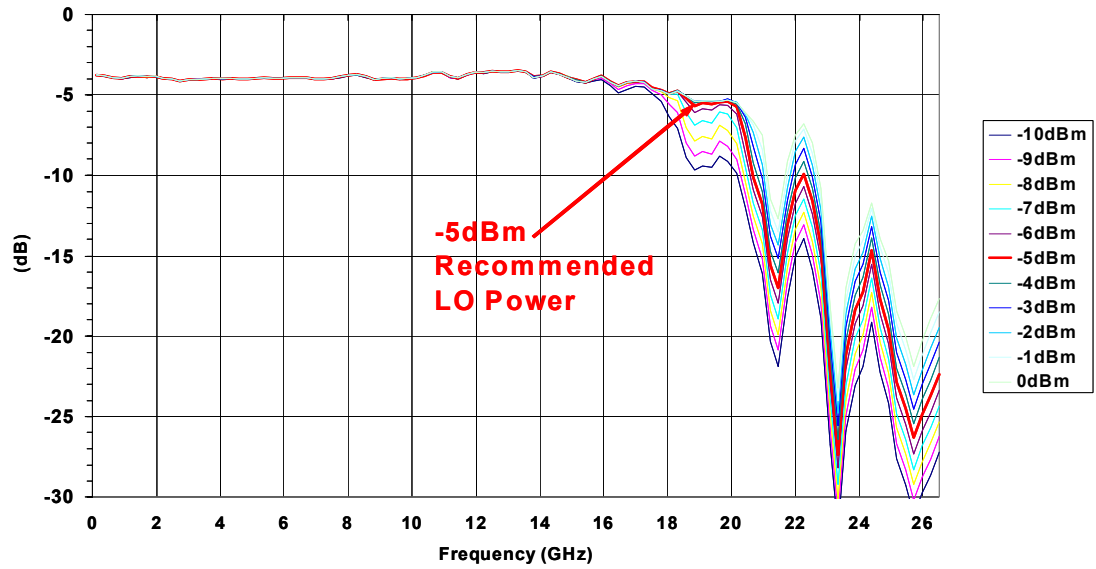

Figure 5.
TC230P Conversion Gain

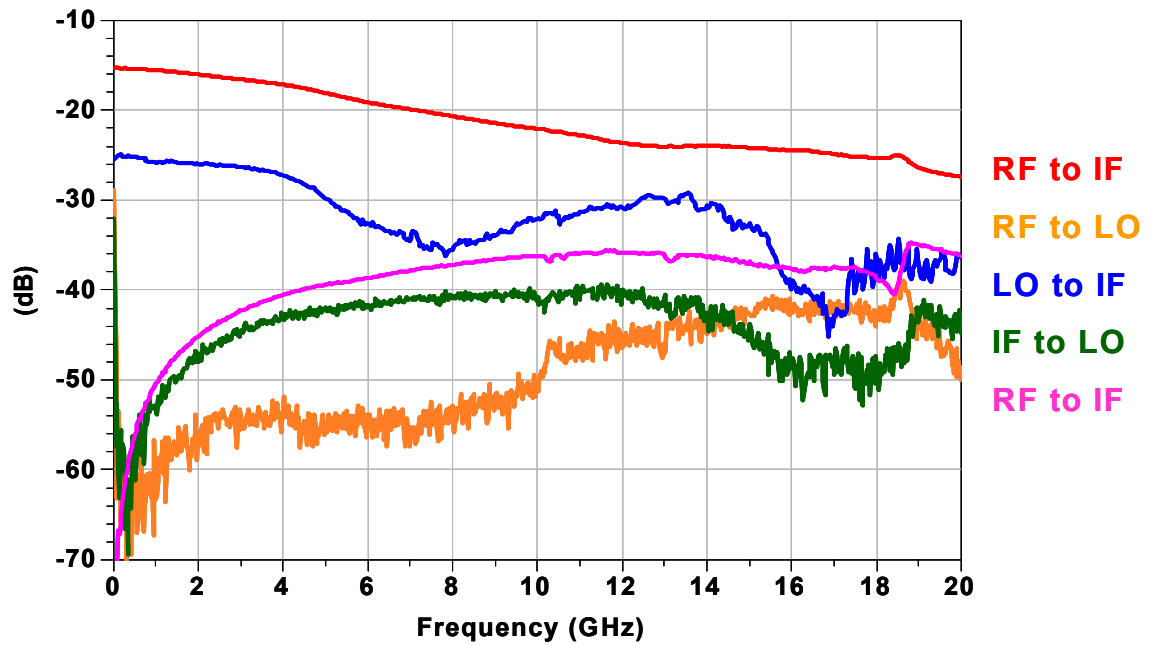

Figure 6.
TC230P Isolation

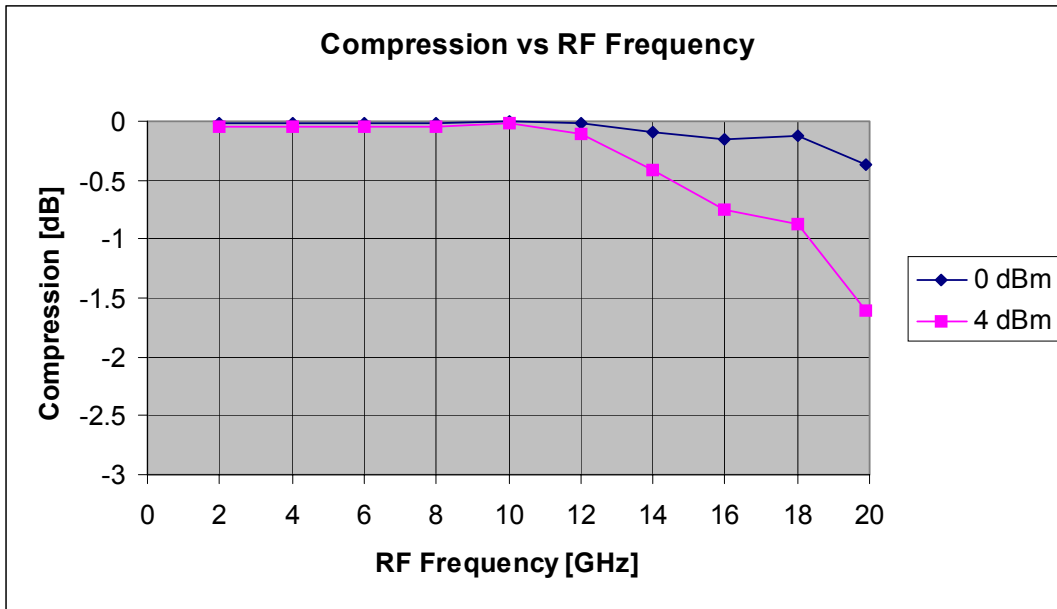

Figure 7.
TC230P Compression

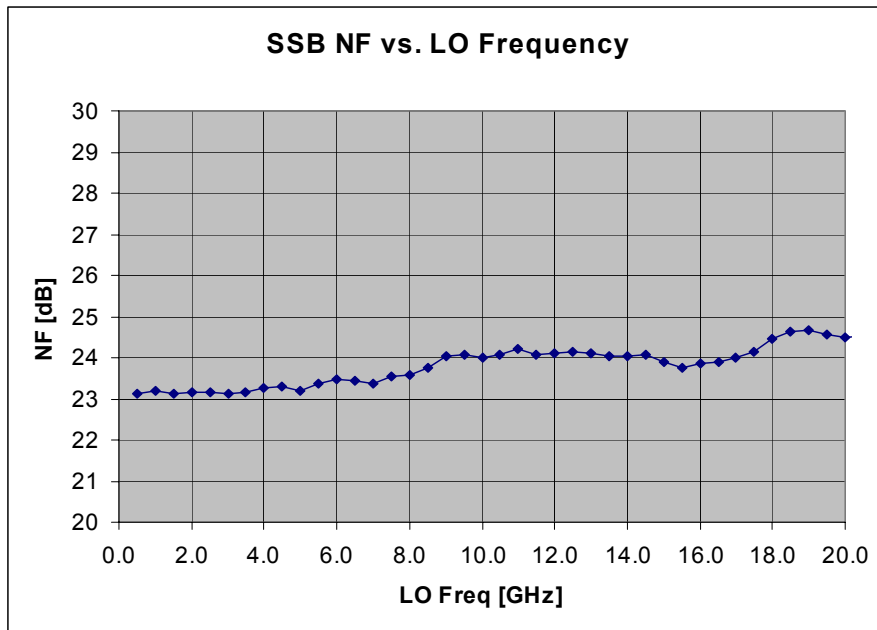

Figure 8.
TC230P Noise Figure

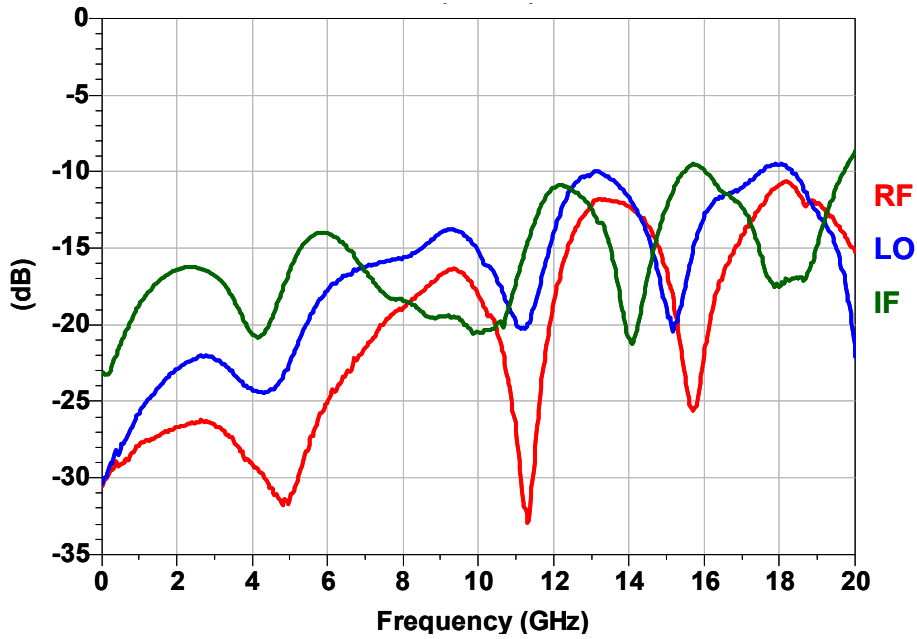

Figure 9.
TC230P RF and LO Port Return

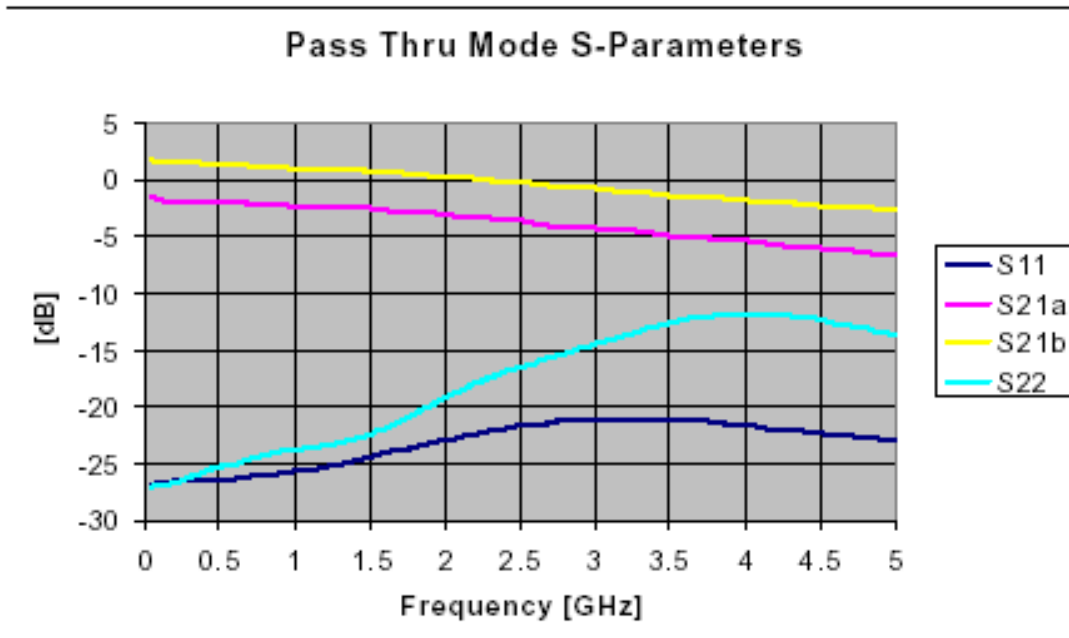

Figure 10.
TC230P Pass Through Mode

This data sheet contains a variety of *typical* and guaranteed performance data. The information supplied should not be interpreted as a complete list of circuit specifications. In this data sheet the term *typical* refers to the 50th percentile performance. For additional information contact WPTC Marketing at 1-577-4482.

G-Cell QFN mixer inherent W-CDMA ACLR. E4438C LO.
Ph. noise -150dBc/Hz@ 5MHz. 40MHz IF, LO = -5dBm

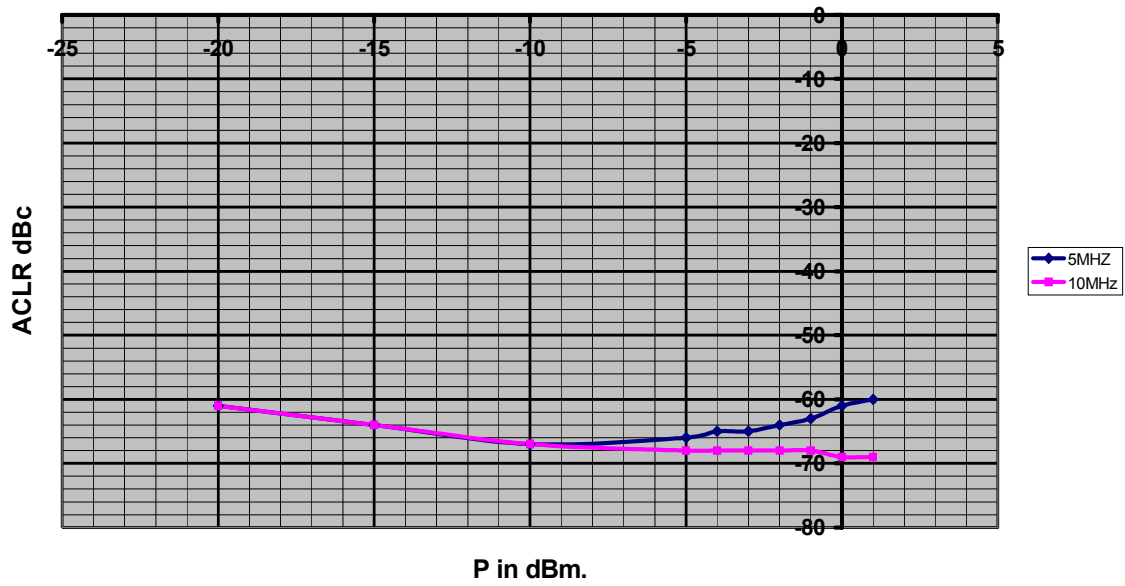

Figure 11.
TC230P Pass Through Mode