

Technical Data

DIODE



maximum ratings

Voltage, Reverse (VZ)	200.0	V	NO.	1N3015RB
Voltage, Reverse Peak (VRM)		V	TYPE	10W-ZENER
Current at VR = 0V (IO)		A		
Current Average Rectified (IF)	2.0	A		
Current Surge Peak (IZM)	0.04	A	CASE	DO-4_UNF
Current, Surge (IFM) at tp =		A		CATHODE TO CASE
Max. Power Dissipation (PT) at TC = 55 °C	10.0	W		
Max. Thermal Resistance (Rth J-C)	12.0	°C/W		
Max. Junction Temperature (TJ)	175.0	°C		

PERFORMANCE CHARACTERISTICS at $T_c = 25^\circ\text{C}$, unless otherwise noted

NO.	SYMBOL	CONDITIONS	MIN.	MAX.	UNITS
1.	VZ	$I_Z = 12.0 \text{ mA}$, $t_p = 100.0 \mu\text{s}$, $\text{dc} = 0.1 \%$	190.0	210.0	V
2.	RZ	$I_Z = 12.0 \text{ mA}$, $\Delta I_Z = 10.0 \%$ I_Z , $f = 1.0 \text{ kHz}$	-	300.0	Ω
3.	RZ	$I_Z = 1.0 \text{ mA}$	-	2.0	$\text{k}\Omega$
4.	IR	$V_R = 152.0 \text{ V}$	-	5.0	μA
5.	VF	$I_F = 2.0 \text{ A}$ (1)	-	1.5	V
6.					
7.					
8.					
9.					
10.					
11.					
12.					
13.					
14.					
15.					
16.					
17.					
18.					
19.					
20.					

Notes (1) pulse-tested $t_p \leq 300 \mu\text{s}$, duty cycle $\leq 2 \%$

DIMENSIONS
in mm

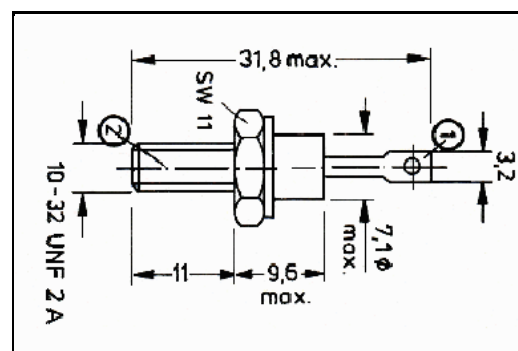

Marking 1N3015RB
Customer GENERAL PURPOSE