

Technical Data

DIODE



maximum ratings

Voltage, Reverse (VR)	1000.0	V	NO.	1N3942G
Voltage, Reverse Peak (VRM)	1160.0	V	TYPE	SILICON
Current at VR = 0V (IO)		A		CONTROLLED
Current Average Rectified (IF)	2.0	A		AVALANCHE
Current Surge Peak (IFM)	6.5	A	CASE	SOD-57
Current, Surge (IFM) at tp = 10 ms	70.0	A		
Max. Power Dissipation (PT) at TC = °C		W		
Max. Thermal Resistance (Rth J-A)	70.0	°C/W		
Max. Junction Temperature (TJ)	175.0	°C		

PERFORMANCE CHARACTERISTICS at T_c = 25°C, unless otherwise noted

NO.	SYMBOL	CONDITIONS	MIN.	MAX.	UNITS
1.	VF	IF = 2.0 A (1)	-	1.1	V
2.	IR	VR = 1000.0 V	-	5.0	μA
3.	IR	VR = 1000.0 V, TC = 150.0° C	-	500.0	μA
4.	VBR	IR = 50.0 μA	1160.0	1500.0	V
5.	PRSM	tp = 10.0 μs	-	1.5	kW
6.					
7.					
8.					
9.					
10.					
11.					
12.					
13.					
14.					
15.					
16.					
17.					
18.					
19.					
20.					

Notes (1)pulse-tested tp ≤ 300 μs, duty cycle ≤ 2 %

DIMENSIONS in mm

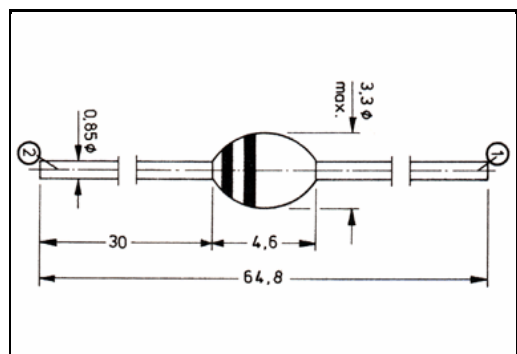

Marking 1N3942G
 Customer GENERAL PURPOSE