



DATA SHEET

SEMICONDUCTOR

1N4728A~1N4764A

1 Watt DO-41G Hermetically Sealed Glass Zener Voltage Regulators

Maximum Ratings

Rating	Symbol	Value	Unit
Maximum Steady State Power Dissipation @ $T_L \leq 50^\circ\text{C}$, Lead Length = 3/8"	P_D	1.0	W
Derate Above 50°C		6.67	mW/°C
Operating and Storage Temperature Range	T_J, T_{stg}	-65 to +200	°C

Specification Features

- Zener Voltage Range = 3.3 V to 100 V
- ESD Rating of Class 3 (>16 KV) per Human Body Model
- DO-41G Package
- Double Slug Type Construction
- Metallurgical Bonded Construction
- Oxide Passivated Die

Mechanical Characteristics

Case : Double slug type, hermetically sealed glass

Finish : All external surfaces are corrosion resistant and leads are readily solderable.

Polarity : Cathode indicated by polarity band

Mounting: Any

Maximum Lead Temperature for Soldering Purposes

260°C, 1/16" from the case for 10 seconds

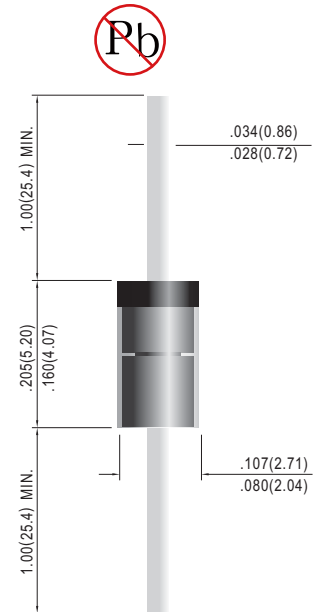

AXIAL LEAD
DO41G



MARKING DIAGRAM

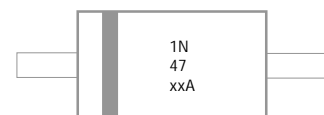

1N47xxA = Device Code

1N4728A~1N4764A

ELECTRICAL CHARACTERISTICS ($T_A = 25^\circ\text{C}$ unless otherwise noted. $V_F = 1.2\text{ V Max @ } I_F = 200\text{mA}$ for all types)

Symbol	Parameter
V_Z	Reverse Zener Voltage @ I_{ZT}
I_{ZT}	Reverse Zener Current
Z_{ZT}	Maximum Zener Impedance @ I_{ZT}
I_{ZK}	Reverse Zener Current
Z_{ZK}	Maximum Zener Impedance @ I_{ZK}
I_R	Reverse Leakage Current @ V_R
V_R	Reverse Voltage
I_F	Forward Current
V_F	Forward Voltage @ I_F
I_s	Surge Current @ $T_A = 25^\circ\text{C}$

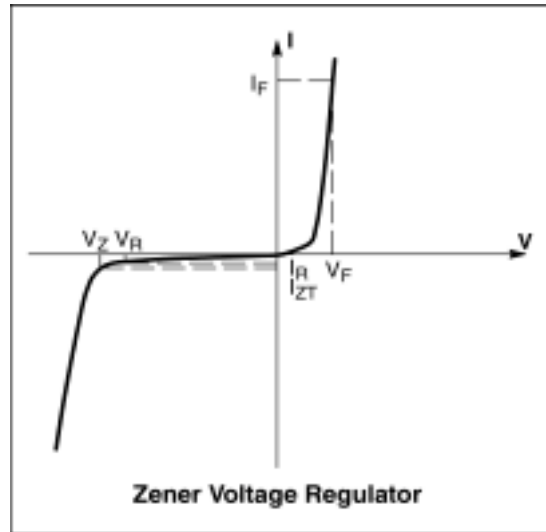

ELECTRICAL CHARACTERISTICS ($T_A = 25^\circ\text{C}$ unless otherwise noted, $V_F = 1.2\text{ V Max @ } I_F = 200\text{mA}$ for all types)

Device (Note 2.)	Device Marking	Zener Voltage (Note 3 & 4.)				Zener Impedance (Note 5.)			Leakage Current		I_s (Note 6.) (mA)
		V_Z (Volts)			@ I_{ZT}	Z_{ZT} @ I_{ZT}	Z_{ZK} @ I_{ZK}	I_R @ V_R			
		Min	Nom	Max	(mA)	(Ω)	(Ω)	(mA)	($\mu\text{A Max}$)	(Volts)	
1N4728A	1N4728A	3.135	3.3	3.465	76	10	400	1	100	1	1380
1N4729A	1N4729A	3.42	3.6	3.78	69	10	400	1	100	1	1260
1N4730A	1N4730A	3.705	3.9	4.095	64	9	400	1	50	1	1190
1N4731A	1N4731A	4.085	4.3	4.515	58	9	400	1	10	1	1070
1N4732A	1N4732A	4.465	4.7	4.935	53	8	500	1	10	1	970
1N4733A	1N4733A	4.845	5.1	5.355	49	7	550	1	10	1	890
1N4734A	1N4734A	5.32	5.6	5.88	45	5	600	1	10	2	810
1N4735A	1N4735A	5.89	6.2	6.51	41	2	700	1	10	3	730
1N4736A	1N4736A	6.46	6.8	7.14	37	3.5	700	1	10	4	660
1N4737A	1N4737A	7.125	7.5	7.875	34	4	700	0.5	10	5	605
1N4738A	1N4738A	7.79	8.2	8.61	31	4.5	700	0.5	10	6	550
1N4739A	1N4739A	8.645	9.1	9.555	28	5	700	0.5	10	7	500
1N4740A	1N4740A	9.5	10	10.5	25	7	700	0.25	10	7.6	454
1N4741A	1N4741A	10.45	11	11.55	23	8	700	0.25	5	8.4	414
1N4742A	1N4742A	11.4	12	12.6	21	9	700	0.25	5	9.1	380

2. TOLERANCE AND TYPE NUMBER DESIGNATION (V_Z)

The type numbers listed have a standard tolerance on the nominal zener voltage of $\pm 5\%$.

3. SPECIALS AVAILABLE INCLUDE

Nominal zener voltages between the voltages shown and tighter voltage tolerances. For detailed information on price, availability and delivery, contact your nearest YEASHIN representative.

4. ZENER VOLTAGE (V_Z) MEASUREMENT

Nominal zener voltage is measured with the device junction in the thermal equilibrium at the lead temperature (T_L) at $30^\circ\text{C} \pm 1^\circ\text{C}$ and $3/8"$ lead length.

5. ZENER IMPEDANCE (Z_Z) DERIVATION

The zener impedance is derived from the 60 cycle AC voltage, which results when an AC current having an RMS value equal to 10% of the DC zener current (I_{ZT} or I_{ZK}) is superimposed on I_{ZT} or I_{ZK} .

6. SURGE CURRENT (I_s) NON-REPETITIVE

The rating listed in the electrical characteristics table is maximum peak, non-repetitive, reverse surge current of $1/2$ square wave or equivalent sine wave pulse of $1/120$ second duration superimposed on the test current I_{ZT} per JEDEC registration; however, actual device capability is as described in figure 5 of the General Data DO-41 Glass.

1N4728A~1N4764A

ELECTRICAL CHARACTERISTICS ($T_A = 25^\circ\text{C}$ unless otherwise noted, $V_F = 1.2\text{ V Max}$ @ $I_F = 200\text{mA}$ for all types)

Device (Note 7.)	Device Marking	Zener Voltage (Note 8 & 9.)				Zener Impedance (Note 10.)			Leakage Current		I_r (Note 11.)
		V_z (Volts)			@ I_{zT}	Z_{zT} @ I_{zT}	Z_{zK} @ I_{zK}		I_R @ V_R		
		Min	Nom	Max	(mA)	(Ω)	(Ω)	(mA)	($\mu\text{A Max}$)	(Volts)	(mA)
1N4743A	1N4743A	12.35	13	13.65	19	10	700	0.25	5	9.9	344
1N4744A	1N4744A	14.25	15	15.75	17	14	700	0.25	5	11.4	304
1N4745A	1N4745A	15.2	16	16.8	15.5	16	700	0.25	5	12.2	285
1N4746A	1N4746A	17.1	18	18.9	14	20	750	0.25	5	13.7	250
1N4747A	1N4747A	19	20	21	12.5	22	750	0.25	5	15.2	225
1N4748A	1N4748A	20.9	22	23.1	11.5	23	750	0.25	5	16.7	205
1N4749A	1N4749A	22.8	24	25.2	10.5	25	750	0.25	5	18.2	190
1N4750A	1N4750A	25.65	27	28.35	9.5	35	750	0.25	5	20.6	170
1N4751A	1N4751A	28.5	30	31.5	8.5	40	1000	0.25	5	22.8	150
1N4752A	1N4752A	31.35	33	34.65	7.5	45	1000	0.25	5	25.1	135
1N4753A	1N4753A	34.2	36	37.8	7	50	1000	0.25	5	27.4	125
1N4754A	1N4754A	37.05	39	40.95	6.5	60	1000	0.25	5	29.7	115
1N4755A	1N4755A	40.85	43	45.15	6	70	1500	0.25	5	32.7	110
1N4756A	1N4756A	44.65	47	49.35	5.5	80	1500	0.25	5	35.8	95
1N4757A	1N4757A	48.45	51	53.55	5	95	1500	0.25	5	38.8	90
1N4758A	1N4758A	53.2	56	58.8	4.5	110	2000	0.25	5	42.6	80
1N4759A	1N4759A	58.9	62	65.1	4	125	2000	0.25	5	47.1	70
1N4760A	1N4760A	64.6	68	71.4	3.7	150	2000	0.25	5	51.7	65
1N4761A	1N4761A	71.25	75	78.75	3.3	175	2000	0.25	5	56	60
1N4762A	1N4762A	77.9	82	86.1	3	200	3000	0.25	5	62.2	55
1N4763A	1N4763A	86.45	91	95.55	2.8	250	3000	0.25	5	69.2	50
1N4764A	1N4764A	95	100	105	2.5	350	3000	0.25	5	76	45

7. TOLERANCE AND TYPE NUMBER DESIGNATION (V_z)

The type numbers listed have a standard tolerance on the nominal zener voltage of $\pm 5\%$.

8. SPECIALS AVAILABLE INCLUDE

Nominal zener voltages between the voltages shown and tighter voltage tolerances. For detailed information on price, availability and delivery, contact your nearest YEAHSIN representative.

9. ZENER VOLTAGE (V_z) MEASUREMENT

Nominal zener voltage is measured with the device junction in the thermal equilibrium at the lead temperature (T_L) at $30^\circ\text{C} \pm 1^\circ\text{C}$ and $3/8"$ lead length.

10. ZENER IMPEDANCE (Z_z) DERIVATION

The zener impedance is derived from the 60 cycle AC voltage, which results when an AC current having an RMS value equal to 10% of the DC zener current (I_{zT} or I_{zK}) is superimposed on I_{zT} or I_{zK} .

11. SURGE CURRENT (I_r) NON-REPETITIVE

The rating listed in the electrical characteristics table is maximum peak, non-repetitive, reverse surge current of $1/2$ square wave or equivalent sine wave pulse of $1/120$ second duration superimposed on the test current I_{zT} per JEDEC registration; however, actual device capability is as described in figure 5 of the General Data DO-41 Glass.

DEVICE CHARACTERISTICS

1N4728A~1N4764A

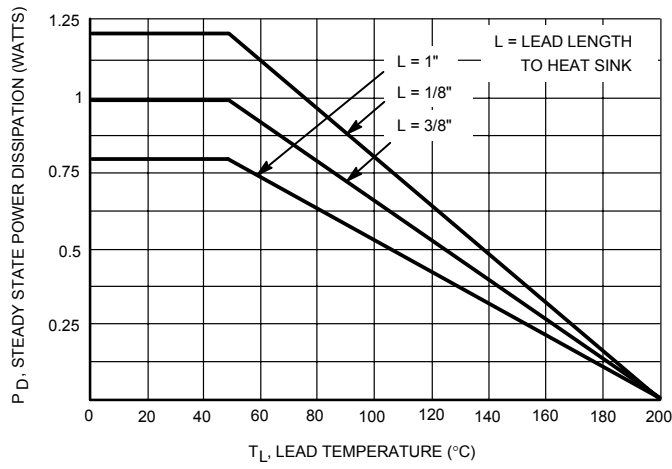

Figure 1. Power Temperature Derating Curve

DEVICE CHARACTERISTICS

1N4728A~1N4764A

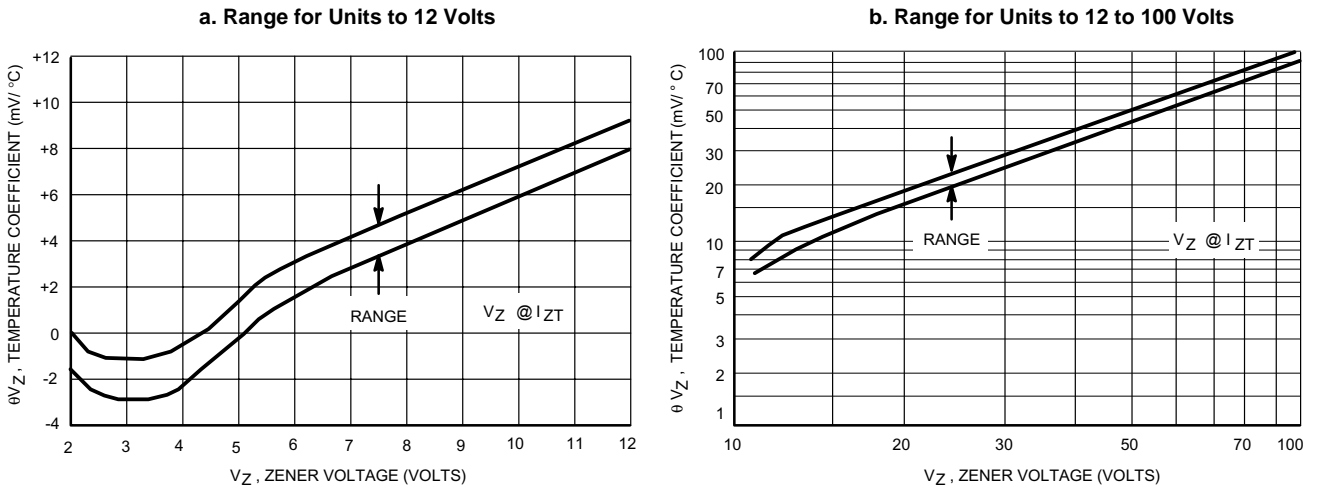

Figure 2. Temperature Coefficients
 (-55 °C to +150 °C temperature range; 90% of the units are in the ranges indicated.)

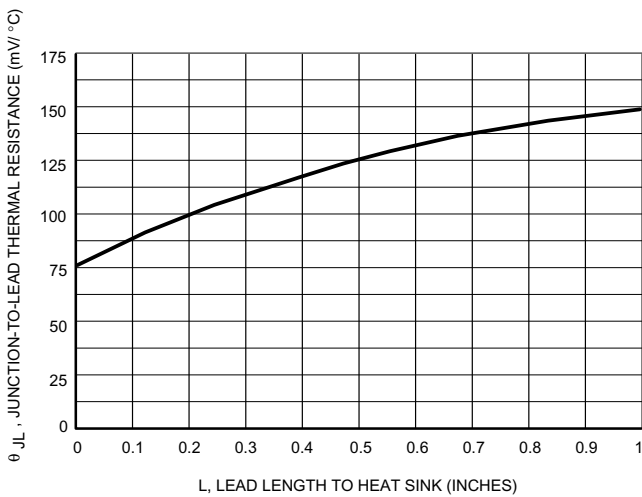

Figure 3. Typical Thermal Resistance versus Lead Length

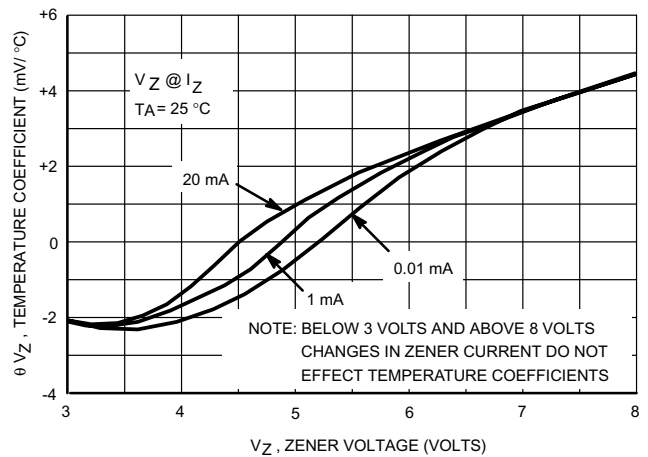
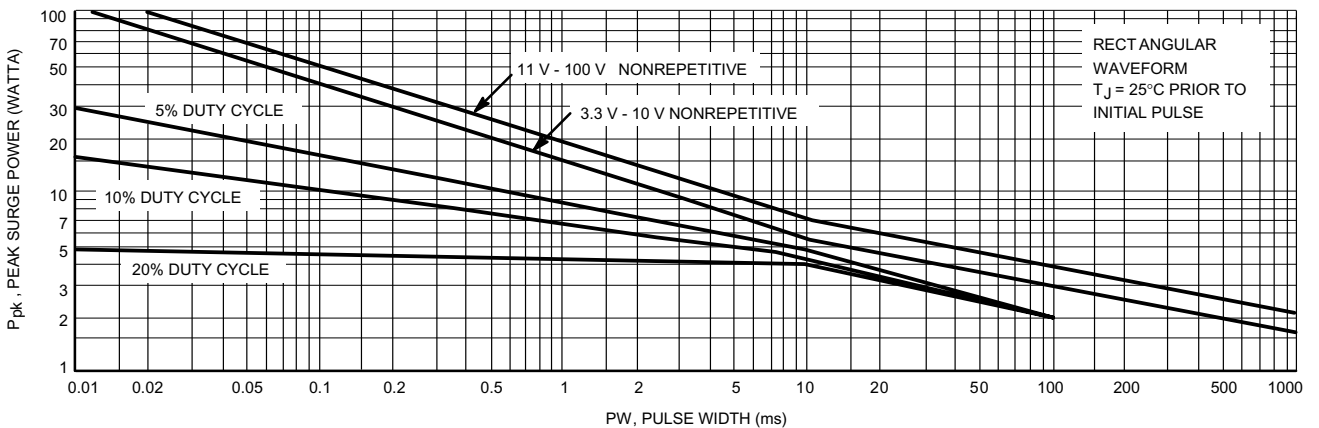

Figure 4. Effect of Zener Current



This graph represents 90 percentile data points.
 For worst case design characteristics, multiply surge power by 2/3.

Figure 5. Maximum Surge Power

DEVICE CHARACTERISTICS

1N4728A~1N4764A

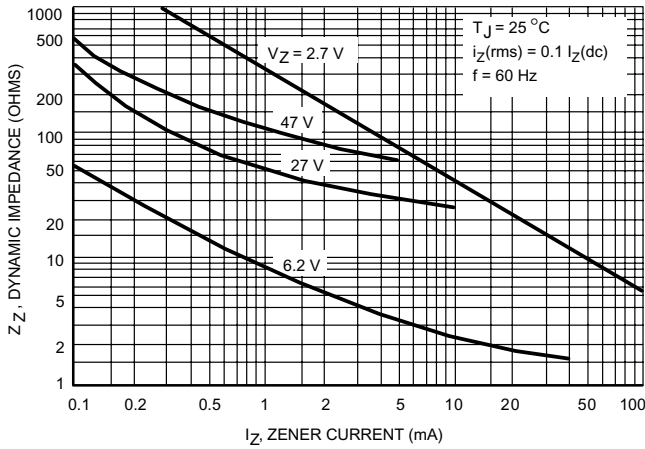

Figure 6. Effect of Zener Current on Zener Impedance

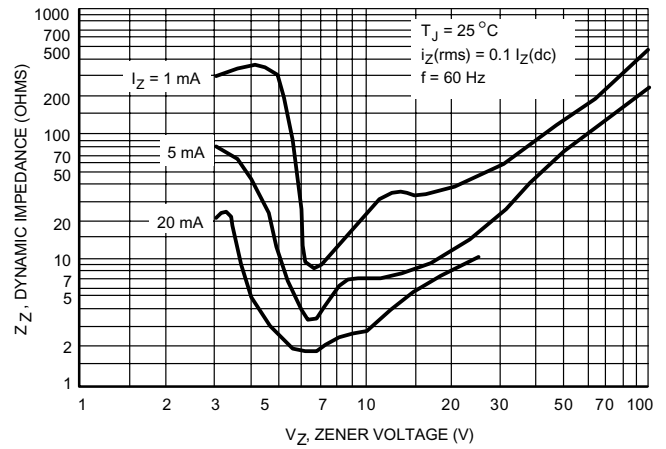

Figure 7. Effect of Zener Voltage on Zener Impedance

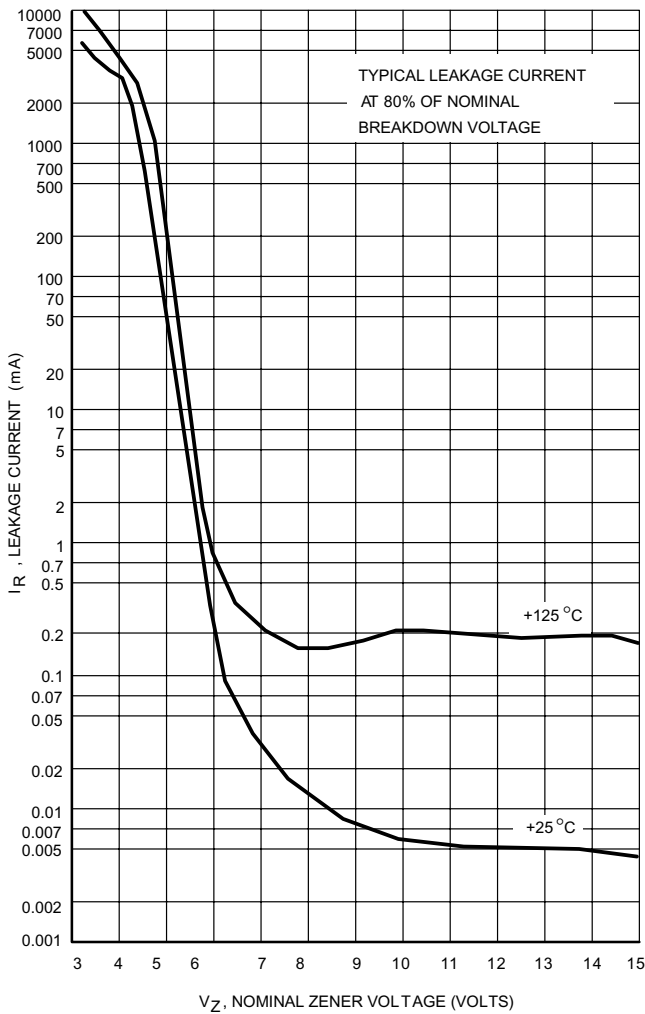

Figure 8. Typical Leakage Current

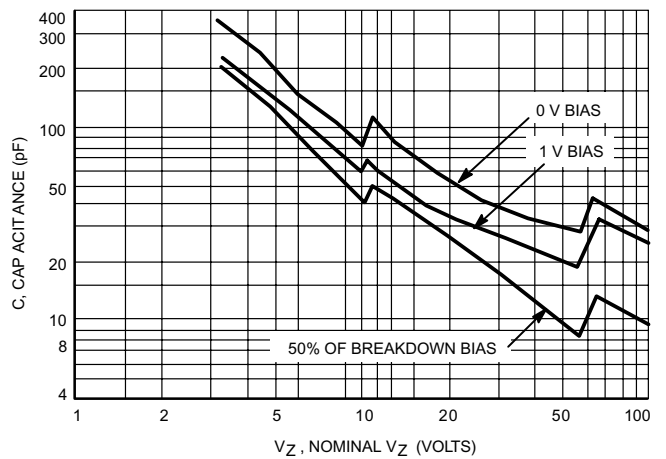

Figure 9. Typical Capacitance versus V_Z

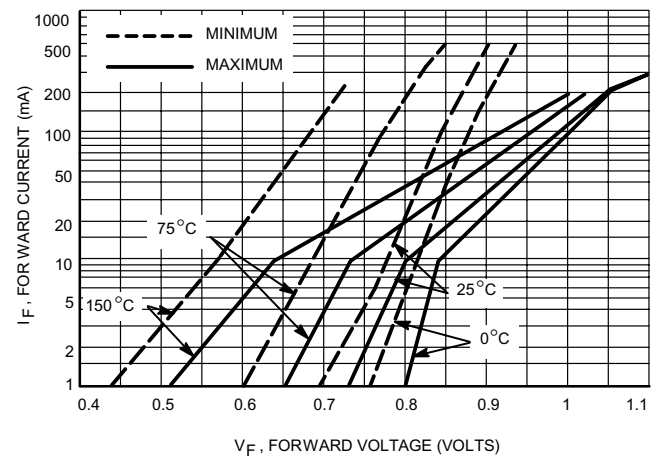

Figure 10. Typical Forward Characteristics