



1N60

Power MOSFET

1.2 Amps, 600 Volts N-CHANNEL MOSFET

■ **DESCRIPTION**

The UTC 1N60 is a high voltage MOSFET and is designed to have better characteristics, such as fast switching time, low gate charge, low on-state resistance and have a high rugged avalanche characteristics. This power MOSFET is usually used at high speed switching applications in power supplies, PWM motor controls, high efficient DC to DC converters and bridge circuits.

■ **FEATURES**

- * $R_{DS(ON)} = 9.3\Omega @ V_{GS} = 10V$.
- * Ultra Low gate charge (typical 5.0nC)
- * Low reverse transfer capacitance ($C_{RSS} =$ typical 3.0 pF)
- * Fast switching capability
- * Avalanche energy specified
- * Improved dv/dt capability, high ruggedness

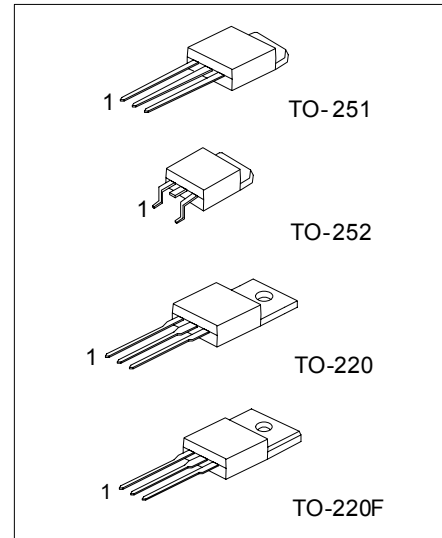

*Pb-free plating product number: 1N60L

■ **SYMBOL**

www.DataSheet4U.com

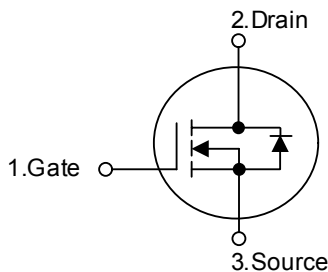

■ **ORDERING INFORMATION**

Order Number		Package	Pin Assignment			Packing
Normal	Lead Free Plating		1	2	3	
1N60-TA3-T	1N60L-TA3-T	TO-220	G	D	S	Tube
1N60-TF3-T	1N60L-TF3-T	TO-220F	G	D	S	Tube
1N60-TM3-T	1N60L-TM3-T	TO-251	G	D	S	Tube
1N60-TN3-R	1N60L-TN3-R	TO-252	G	D	S	Tape Reel
1N60-TN3-T	1N60L-TN3-T	TO-252	G	D	S	Tube

Note: Pin Assignment: G: Gate D: Drain S: Source

<p>1N60L-TA3-T</p>	<p>(1) T: Tube, R: Tape Reel (2) TA3: TO-220, TF3: TO-220F, TM3: TO-251, TN 3: TO-252 (3) L: Lead Free Plating Blank: Pb/Sn</p>
--------------------	---

■ ABSOLUTE MAXIMUM RATINGS ($T_C = 25$, unless otherwise specified)

PARAMETER		SYMBOL	RATINGS	UNIT
Drain-Source Voltage		V_{DSS}	600	V
Gate-Source Voltage		V_{GSS}	± 30	V
Avalanche Current (Note 2)		I_{AR}	1.2	A
Continuous Drain Current	$T_C = 25$	I_D	1.2	A
	$T_C = 100$		0.76	
Drain Current-Pulsed (Note 2)		I_{DP}	4.8	A
Avalanche Energy	Repetitive(Note 2)	E_{AR}	4.0	mJ
	Single Pulse(Note 3)	E_{AS}	50	mJ
Peak Diode Recovery dv/dt (Note 4)		dv/dt	4.5	V/ns
Total Power Dissipation	$T_C=25$	P_D	40	W
	Derate above 25°C		0.32	W/
Junction Temperature		T_J	+150	
Storage Temperature		T_{STG}	-55 ~ +150	

Note:1. Absolute maximum ratings are those values beyond which the device could be permanently damaged.

Absolute maximum ratings are stress ratings only and functional device operation is not implied.

2. Repetitive Rating: Pulse Width Limited by Maximum Junction Temperature
3. $L=64mH$, $I_{AS}=1.2A$, $V_{DD}=50V$, $R_G=25\Omega$, Starting $T_J = 25^\circ C$
4. $I_{SD} \leq 1.2A$, $di/dt \leq 200A/\mu s$, $V_{DD} \leq BV_{DSS}$, Starting $T_J = 25^\circ C$

■ THERMAL DATA

PARAMETER		SYMBOL	RATINGS	UNIT
Thermal Resistance Junction-Ambient	TO-251	θ_{JA}	112	/W
	TO-252		112	
	TO-220		54	
Thermal Resistance Junction-Case	TO-251	θ_{JC}	12	
	TO-252		12	
	TO-220		4	

■ ELECTRICAL CHARACTERISTICS ($T_C=25$, unless otherwise specified.)

PARAMETER		SYMBOL	TEST CONDITIONS	MIN	TYP	MAX	UNIT
Off Characteristics							
Drain-Source Breakdown Voltage		BV_{DSS}	$V_{GS} = 0V, I_D = 250Ma$	600			V
Zero Gate Voltage Drain Current		I_{DSS}	$V_{DS} = 600V, V_{GS} = 0V$			10	Ma
			$V_{DS} = 480V, T_C = 125$			100	Ma
Gate-Body Leakage Current	Forward	I_{GSS}	$V_{GS} = 30V, V_{DS} = 0V$			100	Na
	Reverse		$V_{GS} = -30V, V_{DS} = 0V$			-100	
Breakdown Voltage Temperature Coefficient		BV_{DSS}/T_J	$I_D = 250Ma$		0.4		V/
On Characteristics							
Gate Threshold Voltage		$V_{GS(TH)}$	$V_{DS} = V_{GS}, I_D = 250Ma$	2.0		4.0	V
Static Drain-Source On-Resistance		$R_{DS(ON)}$	$V_{GS} = 10V, I_D = 0.6A$		9.3	11.5	Ω
Forward Transconductance		g_{FS}	$V_{DS} = 50V, I_D = 0.6A$ (Note 1)		0.9		S
Dynamic Characteristics							
Input Capacitance	C_{ISS}	$V_{DS}=25V, V_{GS}=0V, f=1MHz$			120	150	Pf
Output Capacitance	C_{OSS}				20	25	Pf
Reverse Transfer Capacitance	C_{RSS}				3.0	4.0	Pf

■ ELECTRICAL CHARACTERISTICS (Cont.)

PARAMETER	SYMBOL	TEST CONDITIONS	MIN	TYP	MAX	UNIT
Switching Characteristics						
Turn-On Delay Time	$t_{D(ON)}$	$V_{DD}=300V, I_D=1.2A, R_G=50\Omega$ (Note 1,2)		5	20	ns
Rise Time	t_R			25	60	ns
Turn-Off Delay Time	$t_{D(OFF)}$			7	25	ns
Fall Time	t_F			25	60	ns
Total Gate Charge	Q_G	$V_{DS}=480V, V_{GS}=10V, I_D=1.2A$ (Note 1,2)		5.0	6.0	nC
Gate-Source Charge	Q_{GS}			1.0		nC
Gate-Drain Charge	Q_{GD}			2.6		nC
Drain-Source Diode Characteristics						
Drain-Source Diode Forward Voltage	V_{SD}	$V_{GS}=0V, I_{SD} = 1.2A,$			1.4	V
Continuous Drain-Source Current	I_{SD}				1.2	A
Pulsed Drain-Source Current	I_{SM}				4.8	A
Reverse Recovery Time	t_{RR}	$V_{GS}=0V, I_{SD} = 1.2A$		160		ns
Reverse Recovery Charge	Q_{RR}	$di/dt = 100A/\mu s$ (Note1)		0.3		μC

Note: 1. Pulse Test: Pulse Width $\leq 300\mu s$, Duty Cycle $\leq 2\%$

2. Essentially Independent of Operating Temperature

■ TEST CIRCUITS AND WAVEFORMS

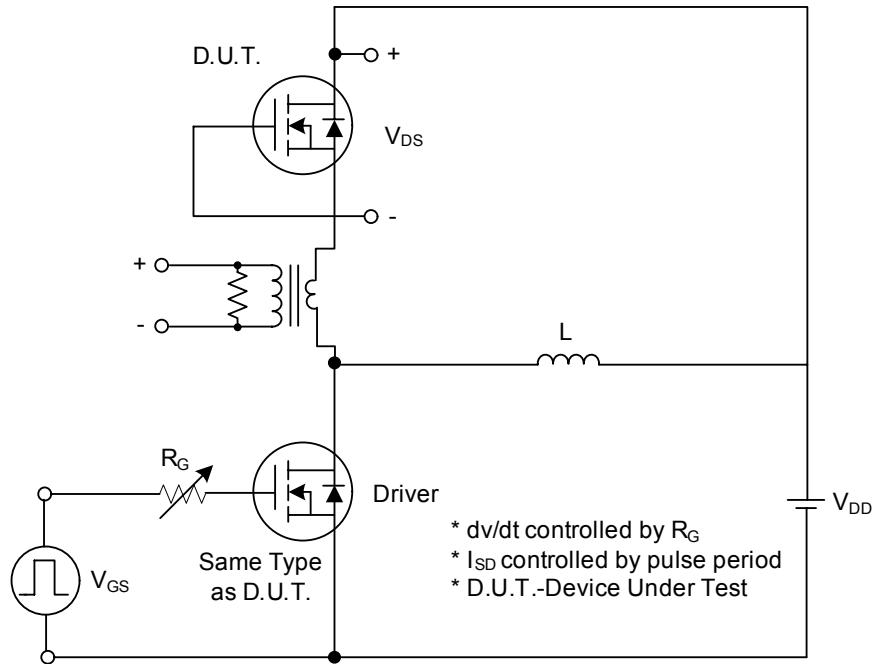

Fig. 1A Peak Diode Recovery dv/dt Test Circuit

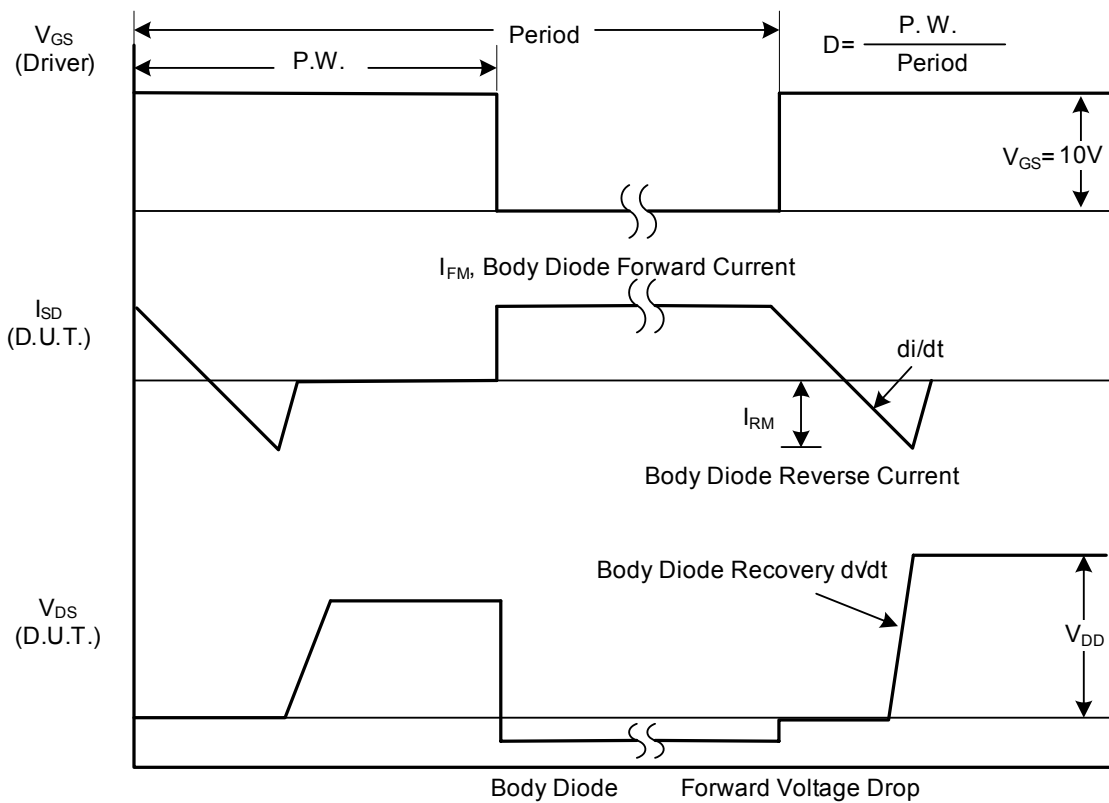

Fig. 1B Peak Diode Recovery dv/dt Waveforms

■ TEST CIRCUITS AND WAVEFORMS (Cont.)

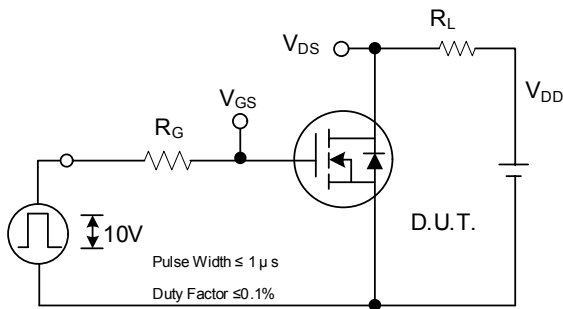

Fig. 2A Switching Test Circuit

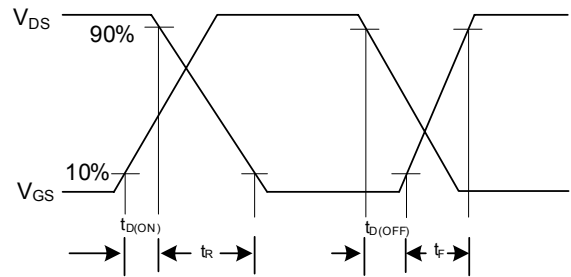

Fig. 2B Switching Waveforms

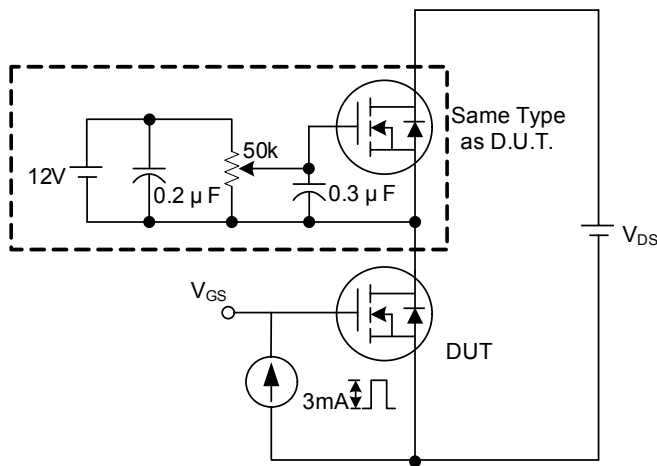

Fig. 3A Gate Charge Test Circuit

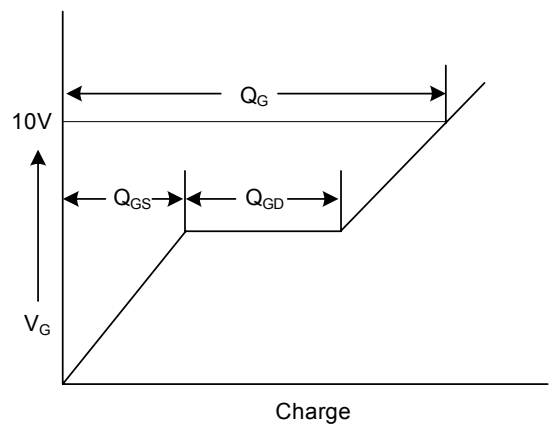

Fig. 3B Gate Charge Waveform

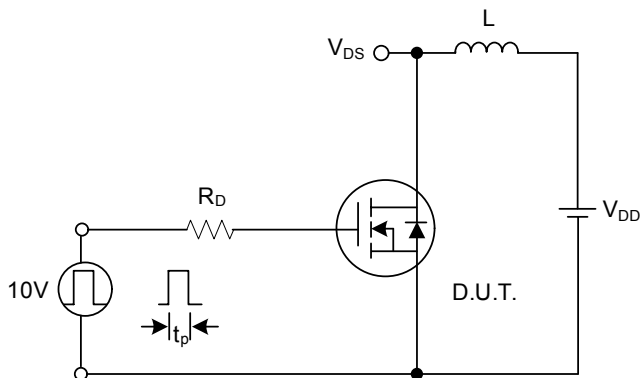

Fig. 4A Unclamped Inductive Switching Test Circuit

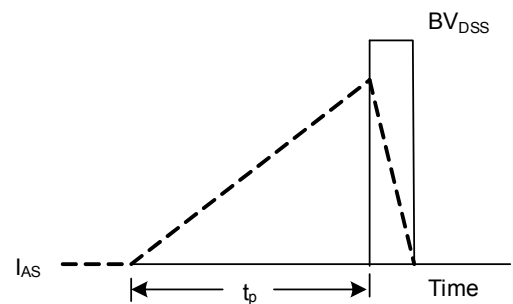
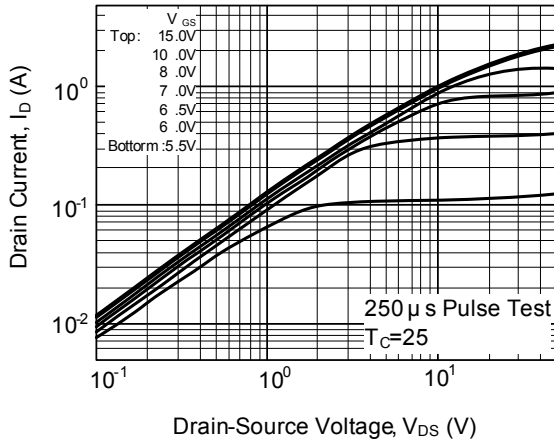

Fig. 4B Unclamped Inductive Switching Waveforms

TYPICAL PERFORMANCE CHARACTERISTICS

Output Characteristics



Transfer Characteristics

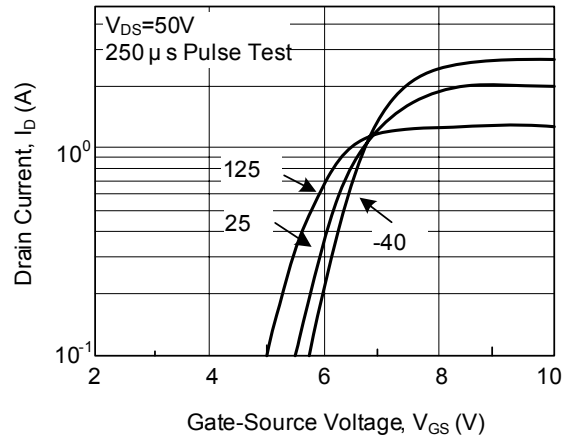

On-Resistance vs. Drain Current

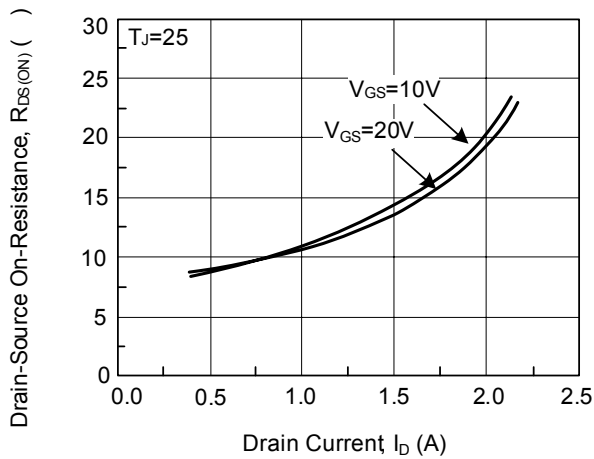

Source- Drain Diode Forward Voltage

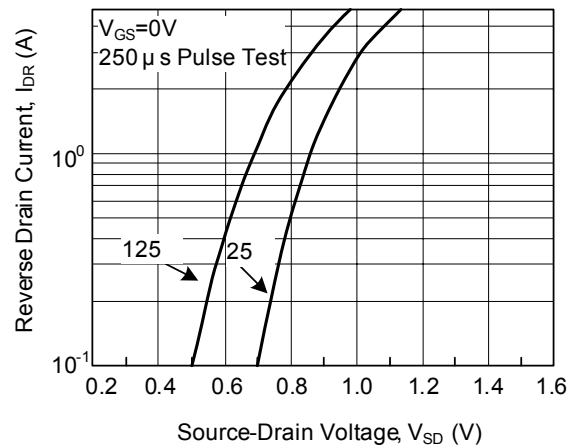

Capacitance vs Drain-Source Voltage

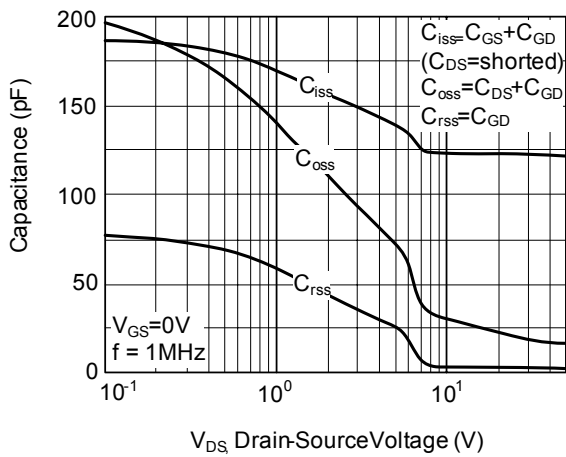

Gate Charge vs. Gate-Source Voltage

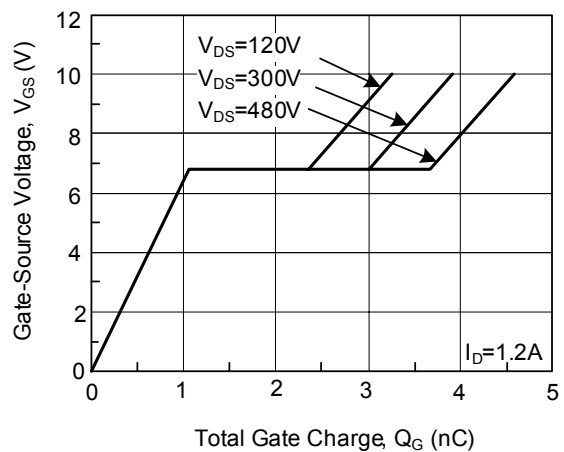

TYPICAL PERFORMANCE CHARACTERISTICS(cont.)

Breakdown Voltage vs Temperature

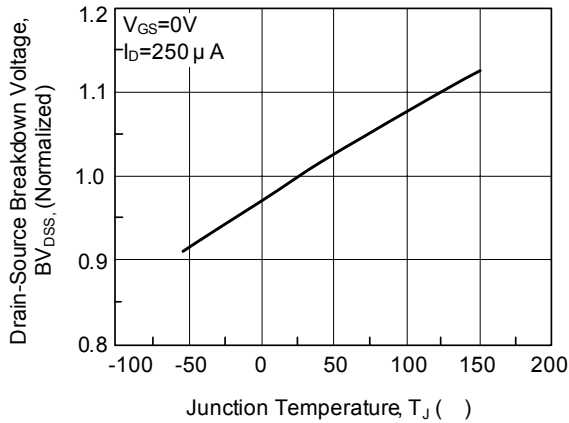

On-Resistance vs. Temperature

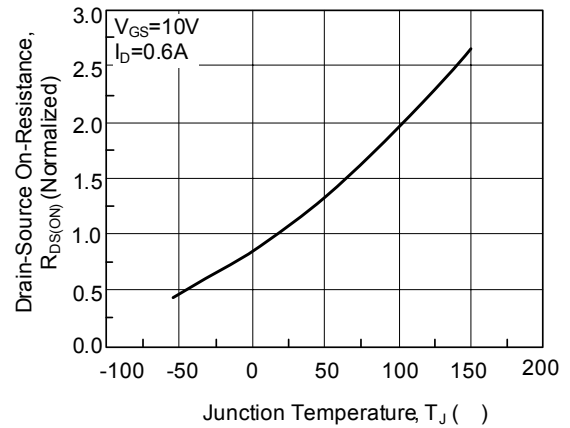

Max. Safe Operating Area

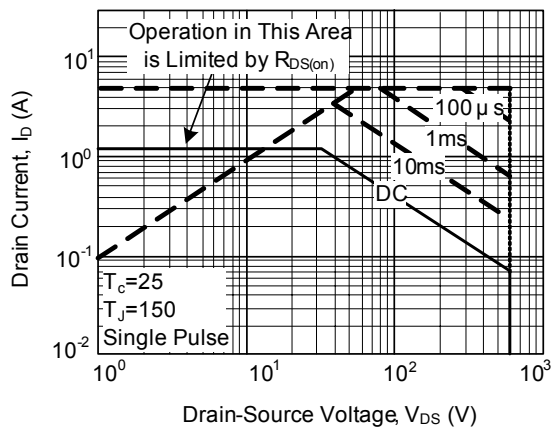

Max. Drain Current vs. Case Temperature

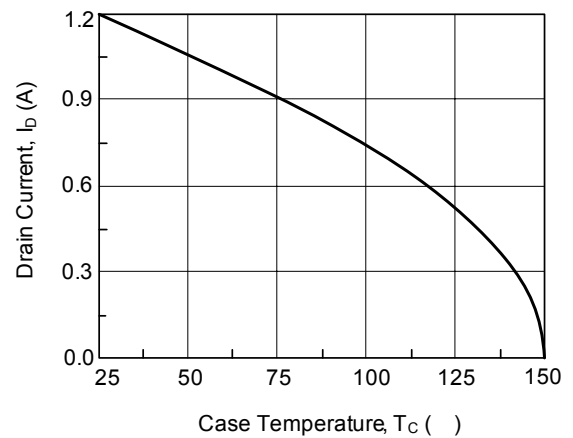

Thermal Response

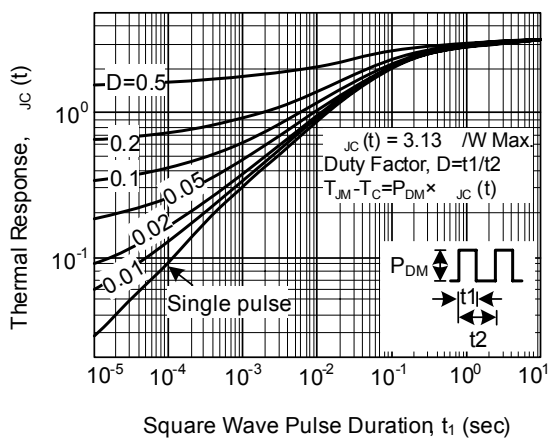

UTC assumes no responsibility for equipment failures that result from using products at values that exceed, even momentarily, rated values (such as maximum ratings, operating condition ranges, or other parameters) listed in products specifications of any and all UTC products described or contained herein. UTC products are not designed for use in life support appliances, devices or systems where malfunction of these products can be reasonably expected to result in personal injury. Reproduction in whole or in part is prohibited without the prior written consent of the copyright owner. The information presented in this document does not form part of any quotation or contract, is believed to be accurate and reliable and may be changed without notice.