

### Features

- Glass Passivated Die Construction
- 1.5W Power Dissipation
- 3.3V – 200V Nominal Zener Voltage
- 5% Standard Vz Tolerance
- Low Inductance
- For Use in Voltage Regulator or Reference
- Plastic Case Material has UL Flammability Classification Rating 94V-0

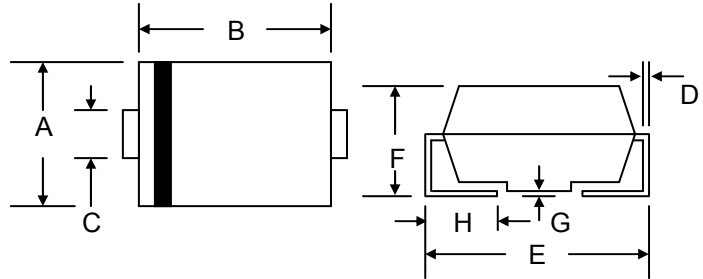

### Mechanical Data

- Case: SMA/DO-214AC, Molded Plastic
- Terminals: Solder Plated, Solderable per MIL-STD-750, Method 2026
- Polarity: Cathode Band
- Marking: Device Code
- Weight: 0.064 grams (approx.)
- **Lead Free: For RoHS / Lead Free Version, Add "-LF" Suffix to Part Number, See Page 5**

SMA/DO-214AC		
Dim	Min	Max
A	2.29	2.92
B	4.00	4.60
C	1.27	1.90
D	0.152	0.305
E	4.80	5.30
F	2.00	2.44
G	0.051	0.203
H	0.76	1.52
All Dimensions in mm		

### Maximum Ratings @T<sub>A</sub>=25°C unless otherwise specified

Characteristic	Symbol	Value	Unit
Power Dissipation at T <sub>L</sub> = 75°C (Note 1) Derate above 75°C	P <sub>D</sub>	1.5 20	W mW/°C
Forward Voltage @ I <sub>F</sub> = 200mA	V <sub>F</sub>	1.2	V
Thermal Resistance, Junction to Ambient (Note 2) Thermal Resistance, Junction to Lead (Note 1)	R <sub>JA</sub> R <sub>JL</sub>	250 50	°C/W
Operating and Storage Temperature Range	T <sub>J</sub> , T <sub>STG</sub>	-65 to +150	°C

- Note: 1. Mounted on FR-4 PCB with 25.4 x 25.4mm copper pads.  
2. Mounted on ceramic substrate with minimum recommended pad layout.

# 1SMA5913B – 1SMA5956B

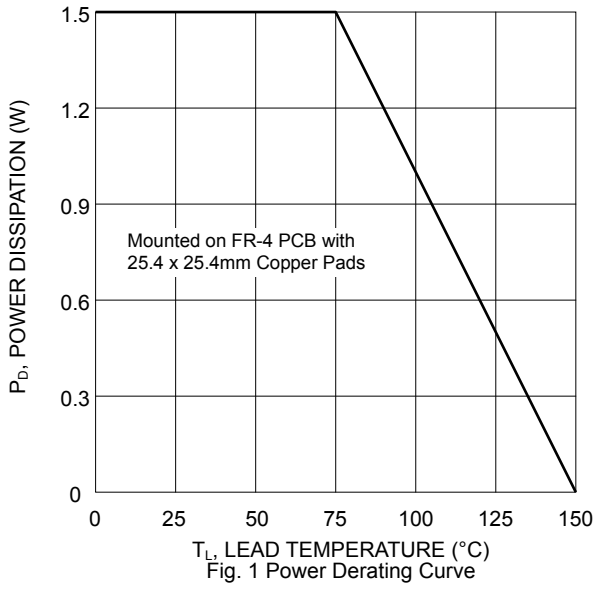

Fig. 1 Power Derating Curve

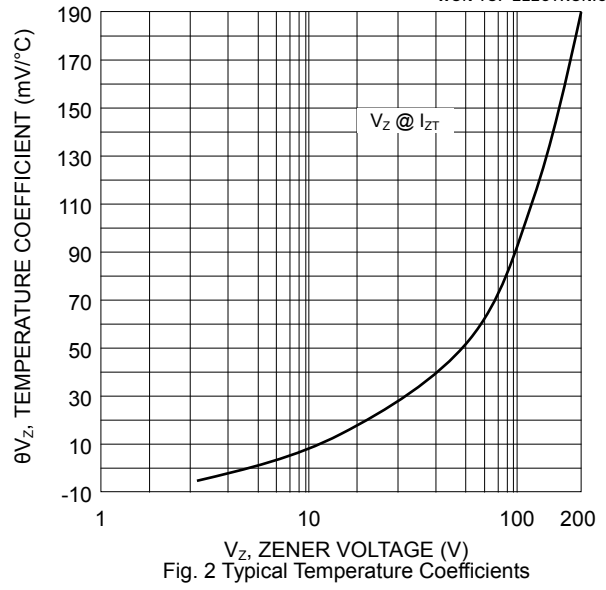

Fig. 2 Typical Temperature Coefficients

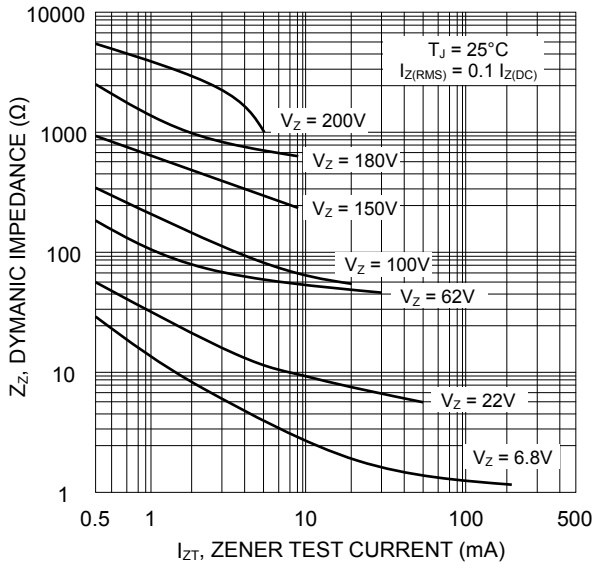

Fig. 3 Dynamic Resistance vs. Zener Current

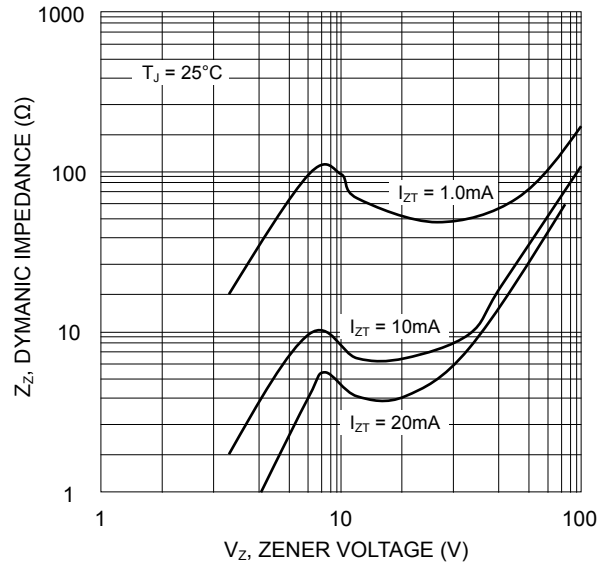

Fig. 3 Dynamic Resistance vs. Zener Voltage

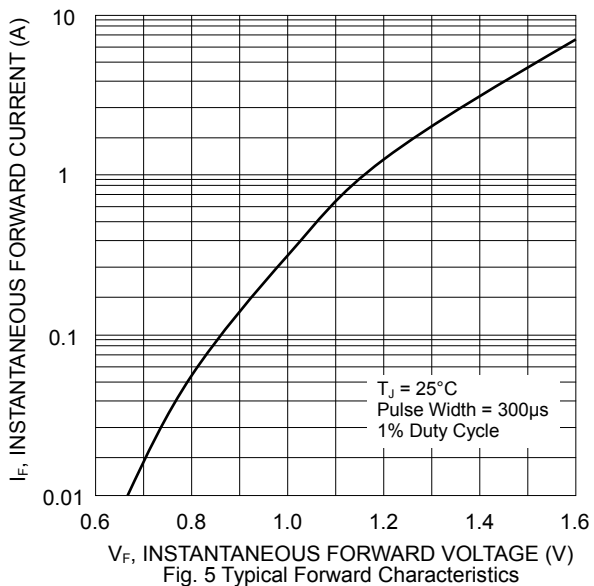

Fig. 5 Typical Forward Characteristics

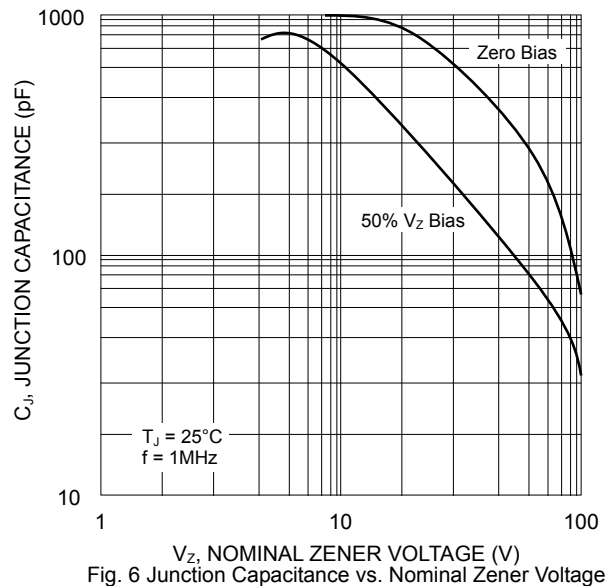

Fig. 6 Junction Capacitance vs. Nominal Zener Voltage

**Electrical Characteristics (@T<sub>A</sub>=25°C unless otherwise specified) Table 1**

Type Number (Note 1)	Device Marking Code	Nominal Zener Voltage (Note 2)	Test Current	Maximum Zener Impedance (Note 3)			Maximum Leakage Current		Max DC Zener Current
		V <sub>Z</sub> @ I <sub>ZT</sub>	I <sub>ZT</sub>	Z <sub>ZT</sub> @ I <sub>ZT</sub>	Z <sub>ZK</sub> @ I <sub>ZK</sub>	I <sub>ZK</sub>	I <sub>R</sub> @ V <sub>R</sub>		I <sub>ZM</sub>
		(V)	(mA)	( $\Omega$ )	( $\Omega$ )	(mA)	( $\mu$ A)	(V)	(mA)
1SMA5913B	813B	3.3	113.6	10.0	500	1.00	100	1.0	455
1SMA5914B	814B	3.6	104.2	9.0	500	1.00	75	1.0	417
1SMA5915B	815B	3.9	96.1	7.5	500	1.00	25	1.0	385
1SMA5916B	816B	4.3	87.2	6.0	500	1.00	5.0	1.0	349
1SMA5917B	817B	4.7	79.8	5.0	500	1.00	5.0	1.5	319
1SMA5918B	818B	5.1	73.5	4.0	350	1.00	5.0	2.0	294
1SMA5919B	819B	5.6	66.9	2.0	250	1.00	5.0	3.0	268
1SMA5920B	820B	6.2	60.5	2.0	200	1.00	2.5	4.0	242
1SMA5921B	821B	6.8	55.1	2.5	200	1.00	2.5	5.2	221
1SMA5922B	822B	7.5	50.0	3.0	400	0.50	2.5	6.0	200
1SMA5923B	823B	8.2	45.7	3.5	400	0.50	2.5	6.5	183
1SMA5924B	824B	9.1	41.2	4.0	500	0.50	2.5	7.0	165
1SMA5925B	825B	10	37.5	4.5	500	0.25	2.5	8.0	150
1SMA5926B	826B	11	34.1	5.5	550	0.25	0.5	8.4	136
1SMA5927B	827B	12	31.2	6.5	550	0.25	0.5	9.1	125
1SMA5928B	828B	13	28.8	7.0	550	0.25	0.5	9.9	115
1SMA5929B	829B	15	25.0	9.0	600	0.25	0.5	11.4	100
1SMA5930B	830B	16	23.4	10.0	600	0.25	0.5	12.2	94
1SMA5931B	831B	18	20.8	12.0	650	0.25	0.5	13.7	83
1SMA5932B	832B	20	18.7	14.0	650	0.25	0.5	15.2	75
1SMA5933B	833B	22	17.0	17.5	650	0.25	0.5	16.7	68
1SMA5934B	834B	24	15.6	19.0	700	0.25	0.5	18.2	63
1SMA5935B	835B	27	13.9	23.0	700	0.25	0.5	20.6	56
1SMA5936B	836B	30	12.5	26.0	750	0.25	0.5	22.8	50
1SMA5937B	837B	33	11.4	33.0	800	0.25	0.5	25.1	45
1SMA5938B	838B	36	10.4	38.0	850	0.25	0.5	27.4	42
1SMA5939B	839B	39	9.6	45.0	900	0.25	0.5	29.7	38
1SMA5940B	840B	43	8.7	53.0	950	0.25	0.5	32.7	35
1SMA5941B	841B	47	8.0	67.0	1000	0.25	0.5	35.8	32
1SMA5942B	842B	51	7.3	70.0	1100	0.25	0.5	38.8	29
1SMA5943B	843B	56	6.7	86.0	1300	0.25	0.5	42.6	27
1SMA5944B	844B	62	6.0	100.0	1500	0.25	0.5	47.1	24
1SMA5945B	845B	68	5.5	120.0	1700	0.25	0.5	51.7	22
1SMA5946B	846B	75	5.0	140.0	2000	0.25	0.5	56.0	20
1SMA5947B	847B	82	4.6	160.0	2500	0.25	0.5	62.2	18
1SMA5948B	848B	91	4.1	200.0	3000	0.25	0.5	69.2	16
1SMA5949B	849B	100	3.7	250.0	3100	0.25	0.5	76.0	15
1SMA5950B	850B	110	3.4	300.0	4000	0.25	0.5	83.6	13
1SMA5951B	851B	120	3.1	380.0	4500	0.25	0.5	91.2	12
1SMA5952B	852B	130	2.9	450.0	5000	0.25	0.5	98.8	11
1SMA5953B	853B	150	2.5	600.0	6000	0.25	0.5	114.0	10
1SMA5954B	854B	160	2.3	700.0	6500	0.25	0.5	121.6	9.0
1SMA5955B	855B	180	2.1	900.0	7000	0.25	0.5	136.8	8.0
1SMA5956B	856B	200	1.9	1200.0	8000	0.25	0.5	152.0	7.0

- Note: 1. Type numbers listed have standard tolerance on the nominal zener voltage of  $\pm 5\%$ .  
 2. Measured under thermal equilibrium and DC (I<sub>ZT</sub>) test conditions.  
 3. The Zener impedance is derived from the 60Hz AC voltage which results when an AC current having an RMS value equal to 10% of the Zener current (I<sub>ZT</sub> or I<sub>ZK</sub>) is superimposed on I<sub>ZT</sub> or I<sub>ZK</sub>. Zener impedance is measured at two points to insure a sharp knee on the breakdown curve and to eliminate unstable units.

## MARKING INFORMATION



Cathode = Polarity Band  
xx = Device Code, See Table 1

## RECOMMENDED FOOTPRINT

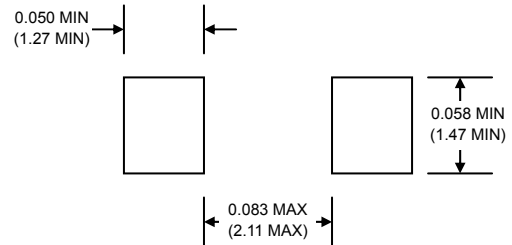

inches(mm)

## PACKAGING INFORMATION

### TAPE & REEL

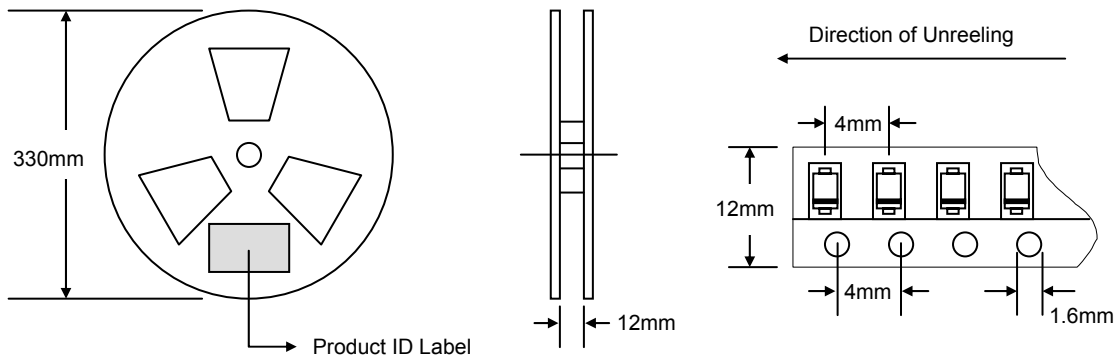

Reel Diameter (mm)	Quantity (PCS)	Inner Box Size L x W x H (mm)	Quantity (PCS)	Carton Size L x W x H (mm)	Quantity (PCS)	Approx. Gross Weight (KG)
330	5,000	340 x 337 x 45	10,000	370 x 370 x 420	80,000	14.0

**Note:** 1. Paper reel, white or gray color.  
2. Components are packed in accordance with EIA standard 481-1 and 481-2.

## ORDERING INFORMATION

Product No.	Package Type	Shipping Quantity
1SMA59xxB-T3	SMA	5000/Tape & Reel

1. Shipping quantity given is for minimum packing quantity only. For minimum order quantity, please consult the Sales Department.
2. **To order RoHS / Lead Free version (with Lead Free finish), add "-LF" suffix to part number above. For example, 1SMA5913B-T3-LF.**

WON-TOP ELECTRONICS and  are registered trademarks of Won-Top Electronics Co., Ltd (WTE). WTE has checked all information carefully and believes it to be correct and accurate. However, WTE cannot assume any responsibility for inaccuracies. Furthermore, this information does not give the purchaser of semiconductor devices any license under patent rights to manufacturer. WTE reserves the right to change any or all information herein without further notice.

**WARNING:** DO NOT USE IN LIFE SUPPORT EQUIPMENT. WTE power semiconductor products are not authorized for use as critical components in life support devices or systems without the express written approval.

**Won-Top Electronics Co., Ltd.**  
No. 44 Yu Kang North 3rd Road,  
Chine Chen Dist., Kaohsiung 806, Taiwan  
**Phone:** 886-7-822-5408 or 886-7-822-5410  
**Fax:** 886-7-822-5417  
**Email:** sales@wontop.com  
**Internet:** <http://www.wontop.com>

*We power your everyday.*