

Features

- Glass Passivated Die Construction
- 5.0W Power Dissipation
- 3.3V – 200V Nominal Zener Voltage
- 5% Standard Vz Tolerance
- Low Inductance
- For Use in Voltage Regulator or Reference
- Plastic Case Material has UL Flammability Classification Rating 94V-0

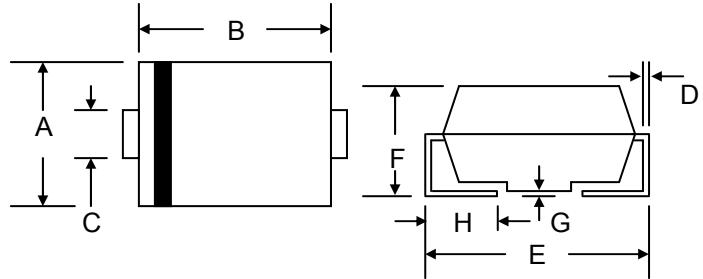

Mechanical Data

- Case: SMC/DO-214AB, Molded Plastic
- Terminals: Solder Plated, Solderable per MIL-STD-750, Method 2026
- Polarity: Cathode Band
- Marking: Device Code
- Weight: 0.21 grams (approx.)
- **Lead Free: For RoHS / Lead Free Version, Add "-LF" Suffix to Part Number, See Page 6**

SMC/DO-214AB		
Dim	Min	Max
A	5.59	6.22
B	6.60	7.11
C	2.75	3.25
D	0.152	0.305
E	7.75	8.13
F	2.00	2.62
G	0.051	0.203
H	0.76	1.52
All Dimensions in mm		

Maximum Ratings @T_A=25°C unless otherwise specified

Characteristic	Symbol	Value	Unit
Power Dissipation at T _L = 75°C (Note 1)	P _D	5.0	W
Forward Voltage @ I _F = 1.0A	V _F	1.2	V
Thermal Resistance, Junction to Ambient (Note 2)	R _{JA}	90	°C/W
Thermal Resistance, Junction to Lead (Note 1)	R _{JL}	25	°C/W
Operating and Storage Temperature Range	T _J , T _{STG}	-65 to +150	°C

- Note: 1. Mounted on FR-4 PCB with 8.0mm² copper pads to each terminal.
 2. Mounted on ceramic substrate with minimum recommended pad layout.

1SMC5333B – 1SMC5388B

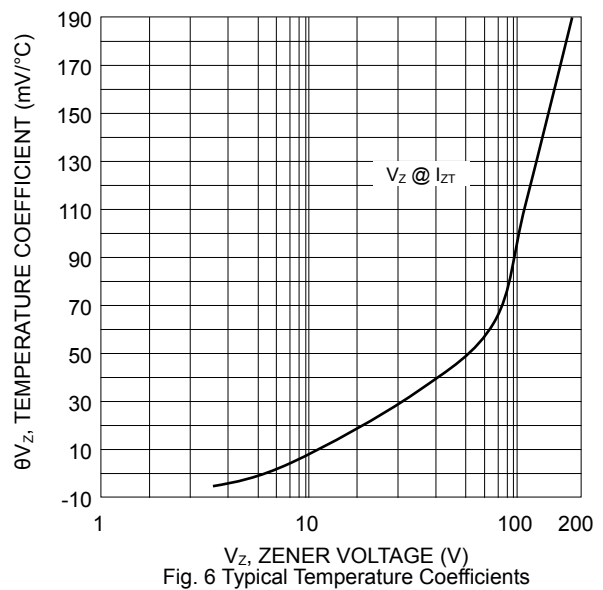
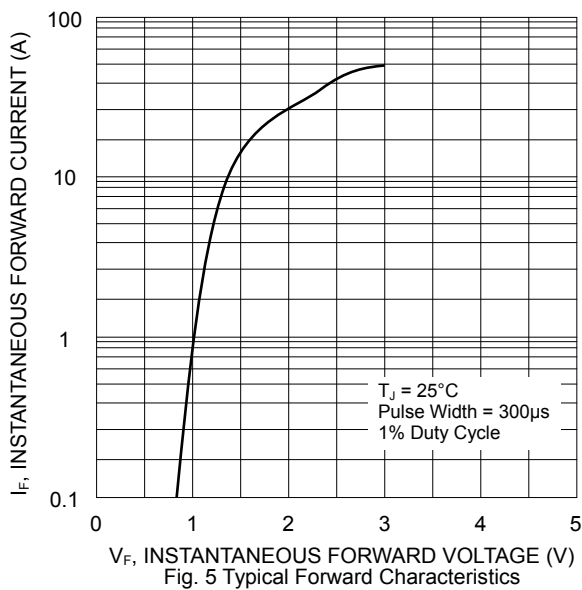
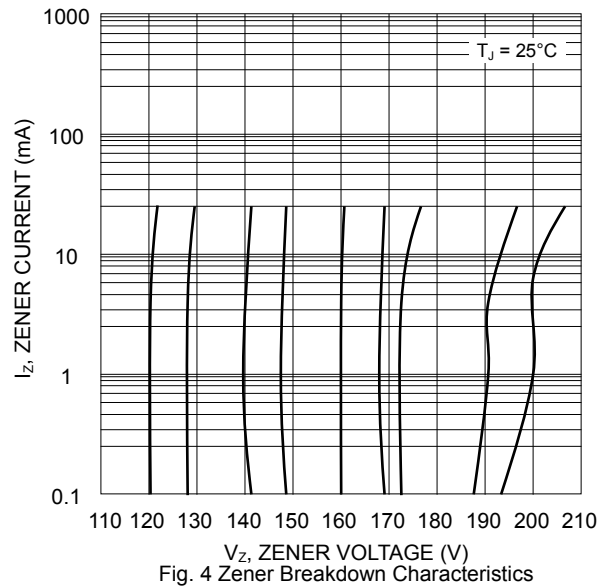
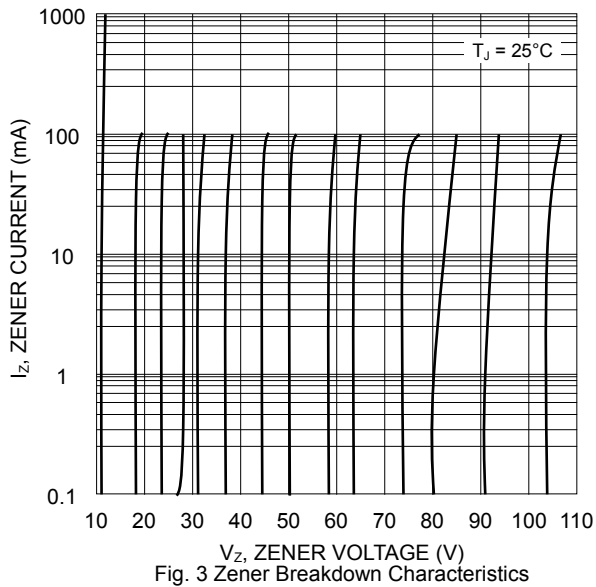
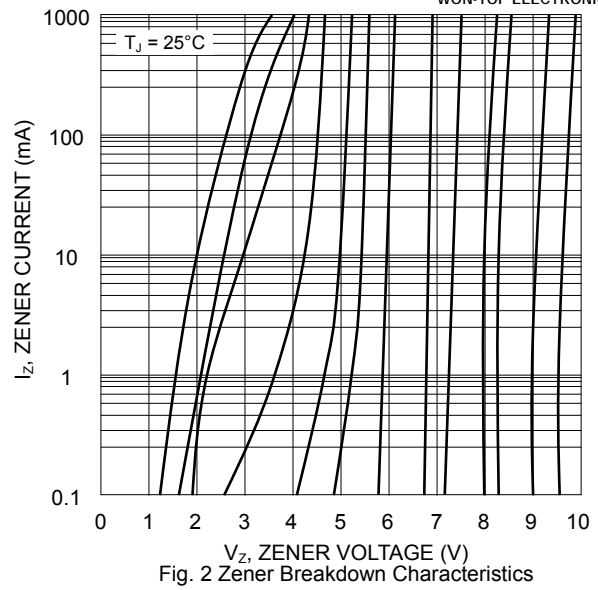
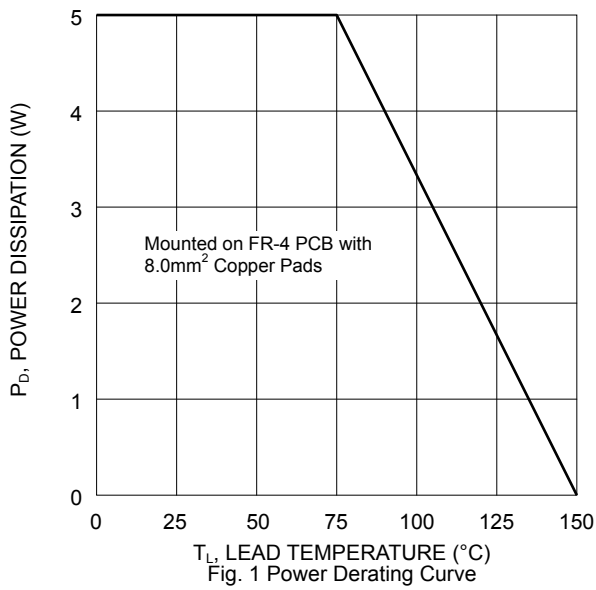

Electrical Characteristics (@T_A=25°C unless otherwise specified) Table 1

Type Number (Note 1)	Device Marking Code	Nominal Zener Voltage (Note 2)	Test Current	Maximum Zener Impedance (Note 3)			Maximum Leakage Current		Max DC Zener Current
		V _Z @ I _{ZT}	I _{ZT}	Z _{ZT} @ I _{ZT}	Z _{ZK} @ I _{ZK}	I _{ZK}	I _R @ V _R		I _{ZM}
		(V)	(mA)	(Ω)	(Ω)	(mA)	(μ A)	(V)	(mA)
1SMC5333B	333B	3.3	380	3.0	400	1.0	300	1.0	1440.0
1SMC5334B	334B	3.6	350	2.5	500	1.0	150	1.0	1320.0
1SMC5335B	335B	3.9	320	2.0	500	1.0	50	1.0	1220.0
1SMC5336B	336B	4.3	290	2.0	500	1.0	10	1.0	1100.0
1SMC5337B	337B	4.7	260	2.0	450	1.0	5.0	1.0	1010.0
1SMC5338B	338B	5.1	240	1.5	400	1.0	1.0	1.0	930.0
1SMC5339B	339B	5.6	220	1.0	400	1.0	1.0	2.0	865.0
1SMC5340B	340B	6.0	200	1.0	300	1.0	1.0	3.0	790.0
1SMC5341B	341B	6.2	200	1.0	200	1.0	1.0	3.0	765.0
1SMC5342B	342B	6.8	175	1.0	200	1.0	10	5.2	700.0
1SMC5343B	343B	7.5	175	1.5	200	1.0	10	5.7	630.0
1SMC5344B	344B	8.2	150	1.5	200	1.0	10	6.2	580.0
1SMC5345B	345B	8.7	150	2.0	200	1.0	10	6.6	545.0
1SMC5346B	346B	9.1	150	2.0	150	1.0	7.5	6.9	520.0
1SMC5347B	347B	10	125	2.0	125	1.0	5.0	7.6	475.0
1SMC5348B	348B	11	125	2.5	125	1.0	5.0	8.4	430.0
1SMC5349B	349B	12	100	2.5	125	1.0	2.0	9.1	395.0
1SMC5350B	350B	13	100	2.5	100	1.0	1.0	9.9	365.0
1SMC5351B	351B	14	100	2.5	75	1.0	1.0	10.6	340.0
1SMC5352B	352B	15	75	2.5	75	1.0	1.0	11.5	315.0
1SMC5353B	353B	16	75	2.5	75	1.0	1.0	12.2	295.0
1SMC5354B	354B	17	70	2.5	75	1.0	0.5	12.9	280.0
1SMC5355B	355B	18	65	2.5	75	1.0	0.5	13.7	264.0
1SMC5356B	356B	19	65	3.0	75	1.0	0.5	14.4	250.0
1SMC5357B	357B	20	65	3.0	75	1.0	0.5	15.2	237.0
1SMC5358B	358B	22	50	3.5	75	1.0	0.5	16.7	216.0
1SMC5359B	359B	24	50	3.5	100	1.0	0.5	18.2	198.0
1SMC5360B	360B	25	50	4.0	110	1.0	0.5	19.0	190.0
1SMC5361B	361B	27	50	5.0	120	1.0	0.5	20.6	176.0
1SMC5362B	362B	28	50	6.0	130	1.0	0.5	21.2	170.0
1SMC5363B	363B	30	40	8.0	140	1.0	0.5	22.8	158.0
1SMC5364B	364B	33	40	10	150	1.0	0.5	25.1	144.0
1SMC5365B	365B	36	30	11	160	1.0	0.5	27.4	132.0
1SMC5366B	366B	39	30	14	170	1.0	0.5	29.7	122.0
1SMC5367B	367B	43	30	20	190	1.0	0.5	32.7	110.0
1SMC5368B	368B	47	25	25	210	1.0	0.5	35.8	100.0
1SMC5369B	369B	51	25	27	230	1.0	0.5	38.8	93.0
1SMC5370B	370B	56	20	35	280	1.0	0.5	42.6	86.0
1SMC5371B	371B	60	20	40	350	1.0	0.5	45.5	79.0
1SMC5372B	372B	62	20	42	400	1.0	0.5	47.1	76.0

Note: 1. Type numbers listed have standard tolerance on the nominal zener voltage of $\pm 5\%$.

2. Measured under thermal equilibrium and DC (I_{ZT}) test conditions.

3. The Zener impedance is derived from the 60Hz AC voltage which results when an AC current having an RMS value equal to 10% of the Zener current (I_{ZT} or I_{ZK}) is superimposed on I_{ZT} or I_{ZK}. Zener impedance is measured at two points to insure a sharp knee on the breakdown curve and to eliminate unstable units.

Electrical Characteristics (@T_A=25°C unless otherwise specified) Table 1 (Cont'd)

Type Number (Note 1)	Device Marking Code	Nominal Zener Voltage (Note 2)	Test Current	Maximum Zener Impedance (Note 3)			Maximum Leakage Current		Max DC Zener Current
		V _Z @ I _{ZT}	I _{ZT}	Z _{ZT} @ I _{ZT}	Z _{ZK} @ I _{ZK}	I _{ZK}	I _R @ V _R		I _{ZM}
		(V)	(mA)	(Ω)	(Ω)	(mA)	(μA)	(V)	(mA)
1SMC5373B	373B	68	20	44	500	1.0	0.5	51.7	70.0
1SMC5374B	374B	75	20	45	620	1.0	0.5	56.0	63.0
1SMC5375B	375B	82	15	65	720	1.0	0.5	62.2	58.0
1SMC5376B	376B	87	15	75	760	1.0	0.5	66.0	54.5
1SMC5377B	377B	91	15	75	760	1.0	0.5	69.2	52.5
1SMC5378B	378B	100	12	90	800	1.0	0.5	76.0	47.5
1SMC5379B	379B	110	12	125	1000	1.0	0.5	83.6	43.0
1SMC5380B	380B	120	10	170	1150	1.0	0.5	91.2	39.5
1SMC5381B	381B	130	10	190	1250	1.0	0.5	98.8	36.6
1SMC5382B	382B	140	8.0	230	1500	1.0	0.5	106.0	34.0
1SMC5383B	383B	150	8.0	330	1500	1.0	0.5	114.0	31.6
1SMC5384B	384B	160	8.0	350	1650	1.0	0.5	122.0	29.4
1SMC5385B	385B	170	8.0	380	1750	1.0	0.5	129.0	28.0
1SMC5386B	386B	180	5.0	430	1750	1.0	0.5	137.0	26.4
1SMC5387B	387B	190	5.0	450	1850	1.0	0.5	144.0	25.0
1SMC5388B	388B	200	5.0	480	1850	1.0	0.5	152.0	23.6

- Note:
1. Type numbers listed have standard tolerance on the nominal zener voltage of ±5%.
 2. Measured under thermal equilibrium and DC (I_{ZT}) test conditions.
 3. The Zener impedance is derived from the 60Hz AC voltage which results when an AC current having an RMS value equal to 10% of the Zener current (I_{ZT} or I_{ZK}) is superimposed on I_{ZT} or I_{ZK}. Zener impedance is measured at two points to insure a sharp knee on the breakdown curve and to eliminate unstable units.

MARKING INFORMATION

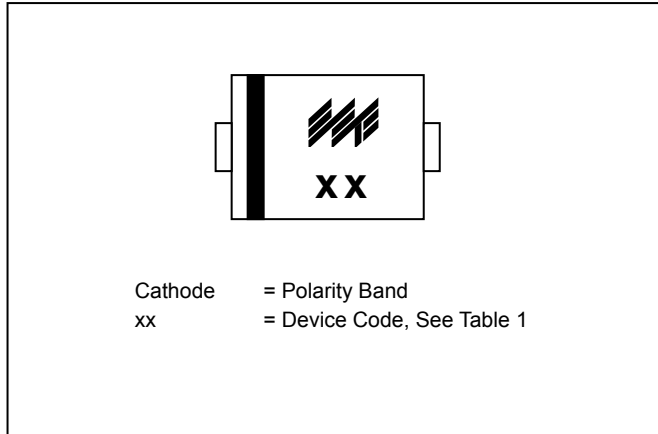

RECOMMENDED FOOTPRINT

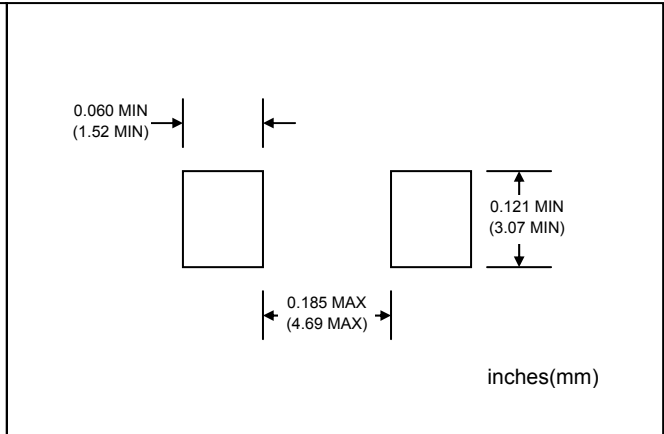

PACKAGING INFORMATION

TAPE & REEL

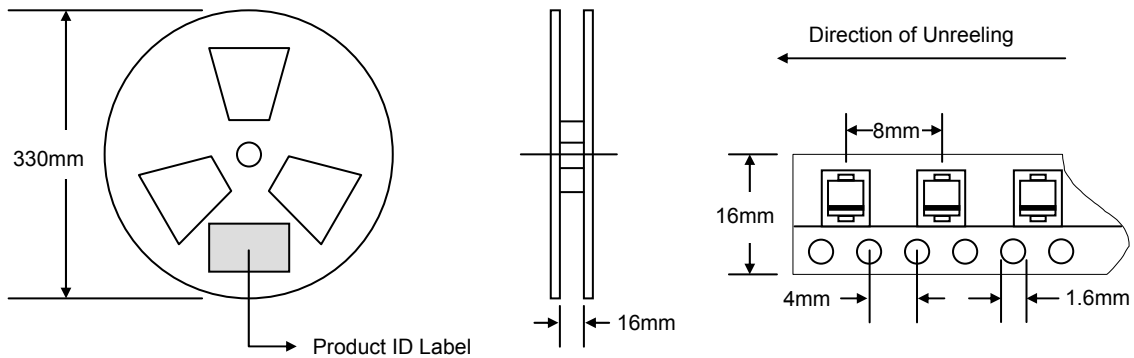

Reel Diameter (mm)	Quantity (PCS)	Inner Box Size L x W x H (mm)	Quantity (PCS)	Carton Size L x W x H (mm)	Quantity (PCS)	Approx. Gross Weight (KG)
330	3,000	340 x 337 x 45	6,000	370 x 370 x 420	48,000	19.0

- Note:**
- Paper reel, white or gray color.
 - Components are packed in accordance with EIA standard 481-1 and 481-2.

ORDERING INFORMATION

Product No.	Package Type	Shipping Quantity
1SMC53xxB-T3	SMC	3000/Tape & Reel

1. Shipping quantity given is for minimum packing quantity only. For minimum order quantity, please consult the Sales Department.
2. **To order RoHS / Lead Free version (with Lead Free finish), add "-LF" suffix to part number above. For example, 1SMC5333B-T3-LF.**

WON-TOP ELECTRONICS and  are registered trademarks of Won-Top Electronics Co., Ltd (WTE). WTE has checked all information carefully and believes it to be correct and accurate. However, WTE cannot assume any responsibility for inaccuracies. Furthermore, this information does not give the purchaser of semiconductor devices any license under patent rights to manufacturer. WTE reserves the right to change any or all information herein without further notice.

WARNING: DO NOT USE IN LIFE SUPPORT EQUIPMENT. WTE power semiconductor products are not authorized for use as critical components in life support devices or systems without the express written approval.

Won-Top Electronics Co., Ltd.
No. 44 Yu Kang North 3rd Road,
Chine Chen Dist., Kaohsiung 806, Taiwan
Phone: 886-7-822-5408 or 886-7-822-5410
Fax: 886-7-822-5417
Email: sales@wontop.com
Internet: <http://www.wontop.com>

We power your everyday.