

**Major Ratings and Characteristics**

Characteristics	Values	Units
$I_{F(AV)}$ Rectangular waveform	200	A
$V_{RRM}$ range	135 - 150	V
$I_{FSM}$ @tp = 5 $\mu$ s sine	10,000	A
$V_F$ @100Apk, $T_J=125^\circ\text{C}$ (per leg)	0.71	V
$T_J$ range	-55 to 175	$^\circ\text{C}$

**Description/ Features**

The 209CNQ center tap Schottky rectifier module series has been optimized for low reverse leakage at high temperature. The proprietary barrier technology allows for reliable operation up to 175  $^\circ\text{C}$  junction temperature. Typical applications are in high current switching power supplies, plating power supplies, UPS systems, converters, free-wheeling diodes, welding, and reverse battery protection.

- 175  $^\circ\text{C}$   $T_J$  operation
- Center tap module
- Low forward voltage drop
- High frequency operation
- Guard ring for enhanced ruggedness and long term reliability
- Lead-Free

**Case Styles**



TO-244

## Voltage Ratings

Part number	209CNQ135PbF	209CNQ150PbF
$V_R$ Max. DC Reverse Voltage (V)	135	150
$V_{RWM}$ Max. Working Peak Reverse Voltage (V)		

## Absolute Maximum Ratings

Parameters	209CNQ	Units	Conditions
$I_{F(AV)}$ Max. Average Forward Current (Per Leg) * See Fig. 5 (Per Device)	100	A	50% duty cycle @ $T_C = 131^\circ\text{C}$ , rectangular wave form
	200		
$I_{FSM}$ Max. Peak One Cycle Non-Repetitive Surge Current (Per Leg) * See Fig. 7	10,000	A	5 $\mu\text{s}$ Sine or 3 $\mu\text{s}$ Rect. pulse 10ms Sine or 6ms Rect. pulse Following any rated load condition and with rated $V_{RWM}$ applied
	1200		
$E_{AS}$ Non-Repetitive Avalanche Energy (Per Leg)	15	mJ	$T_J = 25^\circ\text{C}$ , $I_{AS} = 13$ Amps, $L = 0.2$ mH
$I_{AR}$ Repetitive Avalanche Current (Per Leg)	1	A	Current decaying linearly to zero in 1 $\mu\text{sec}$ Frequency limited by $T_J$ max. $V_A = 1.5 \times V_R$ typical

## Electrical Specifications

Parameters	209CNQ	Units	Conditions
$V_{FM}$ Max. Forward Voltage Drop (Per Leg) * See Fig. 1 (1)	1.06	V	@ 100A $T_J = 25^\circ\text{C}$
	1.33	V	@ 200A
	0.74	V	@ 100A $T_J = 125^\circ\text{C}$
	0.88	V	@ 200A
$I_{RM}$ Max. Reverse Leakage Current (Per Leg) * See Fig. 2 (1)	3	mA	$T_J = 25^\circ\text{C}$ $V_R = \text{rated } V_R$
	45	mA	$T_J = 125^\circ\text{C}$
$C_T$ Max. Junction Capacitance (Per Leg)	3000	pF	$V_R = 5V_{DC}$ (test signal range 100Khz to 1Mhz) $25^\circ\text{C}$
$L_S$ Typical Series Inductance (Per Leg)	7.0	nH	From top of terminal hole to mounting plane
$dv/dt$ Max. Voltage Rate of Change (Rated $V_R$ )	10000	V/ $\mu\text{s}$	

(1) Pulse Width < 300 $\mu\text{s}$ , Duty Cycle <2%

## Thermal - Mechanical Characteristics

Parameters	Min	Typ	Max	Units
$T_J$ Max. Junction Temperature Range	- 55	-	175	$^\circ\text{C}$
$T_{Stg}$ Max. Storage Temperature Range	- 55	-	175	
$R_{thJC}$ Thermal Resistance, Junction to Case	Per Leg	-	0.38	$^\circ\text{C}/\text{W}$
	Per Module	-	0.19	K/W
$R_{thCS}$ Thermal Resistance, Case to Heatsink	-	0.10	-	
Wt Weight	-	68 (2.4)	-	g (oz)
T Mounting Torque	35.4 (4)	-	53.1 (6)	lbf*in
	30 (3.4)	-	40 (4.6)	(Nm)
	30 (3.4)	-	44.2 (5)	
Vertical Pull	-	-	80	lbf.in
2 inch Lever Pull	-	-	35	

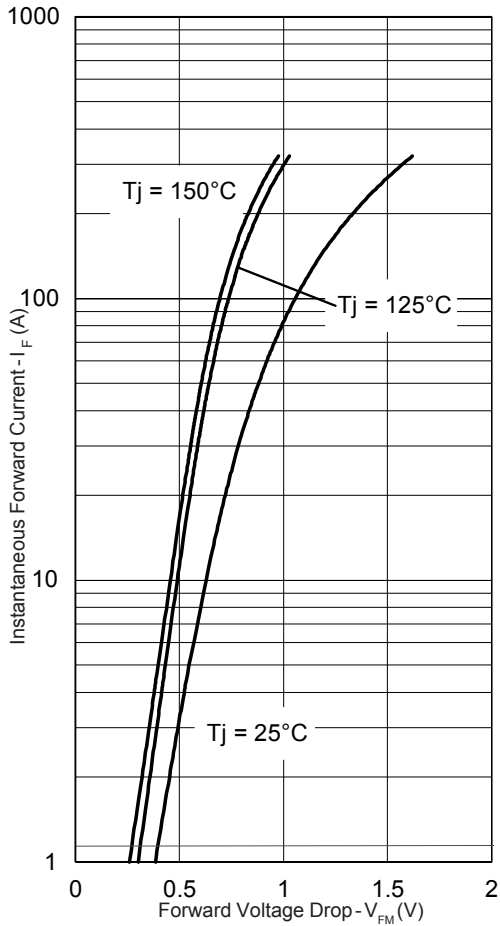

Fig. 1 - Max. Forward Voltage Drop Characteristics

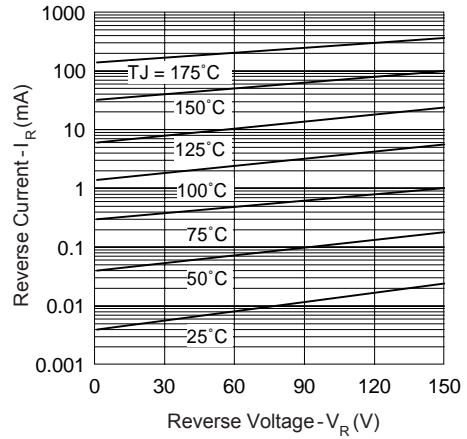

Fig. 2 - Typical Values Of Reverse Current Vs. Reverse Voltage

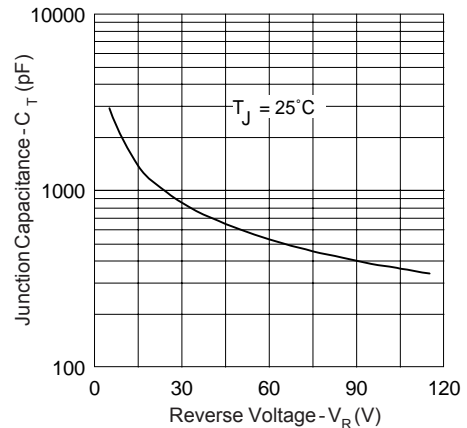

Fig. 3 - Typical Junction Capacitance Vs. Reverse Voltage

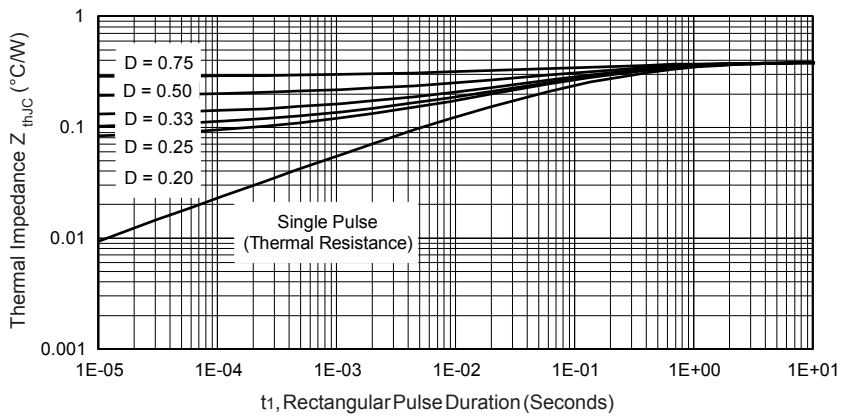

Fig. 4 - Max. Thermal Impedance  $Z_{thJC}$  Characteristics

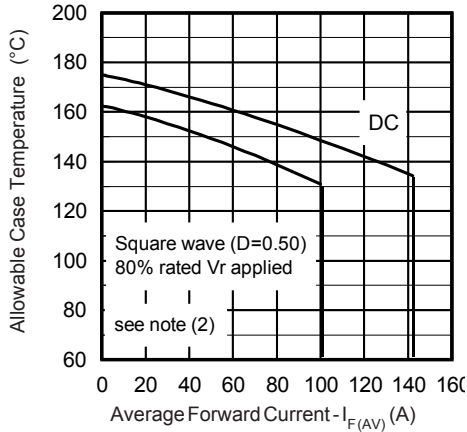

Fig. 5 - Max. Allowable Case Temperature Vs. Average Forward Current

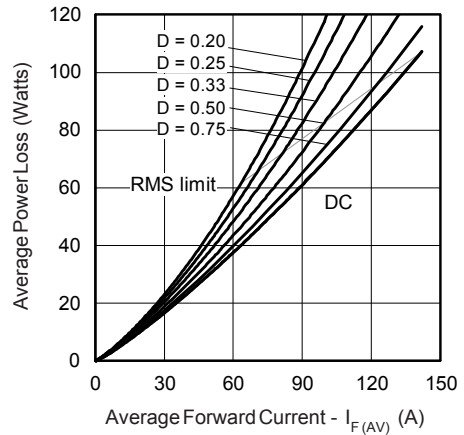

Fig. 6 - Forward Power Loss Characteristics

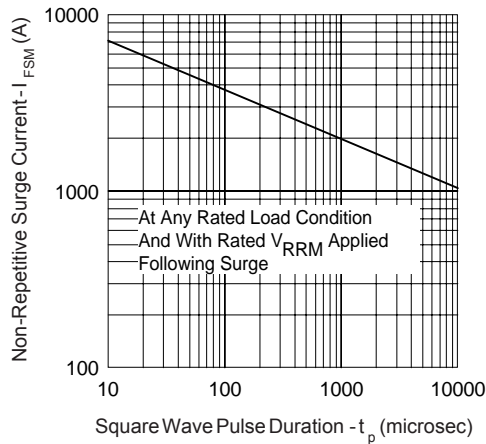

Fig. 7 - Max. Non-Repetitive Surge Current

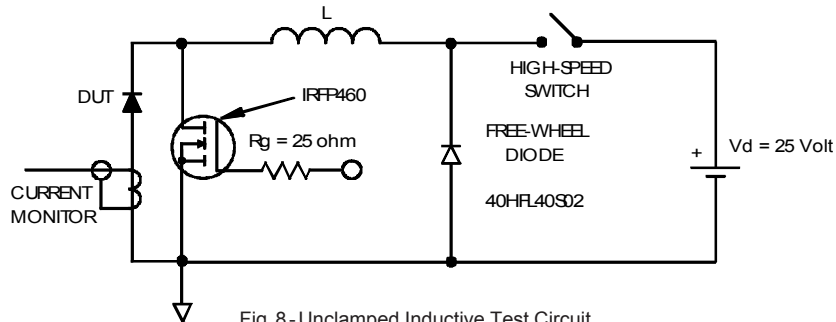

Fig. 8 - Unclamped Inductive Test Circuit

(2) Formula used:  $T_C = T_J + (P_d + P_{d_{REV}}) \times R_{thJC}$ ;

$P_d = \text{Forward Power Loss} = I_{F(AV)} \times V_{FM} @ (I_{F(AV)} / D)$  (see Fig. 6);

$P_{d_{REV}} = \text{Inverse Power Loss} = V_{R1} \times I_{R1} (1 - D)$ ;  $I_{R1} @ V_{R1} = 80\% \text{ rated } V_R$

Outline Table

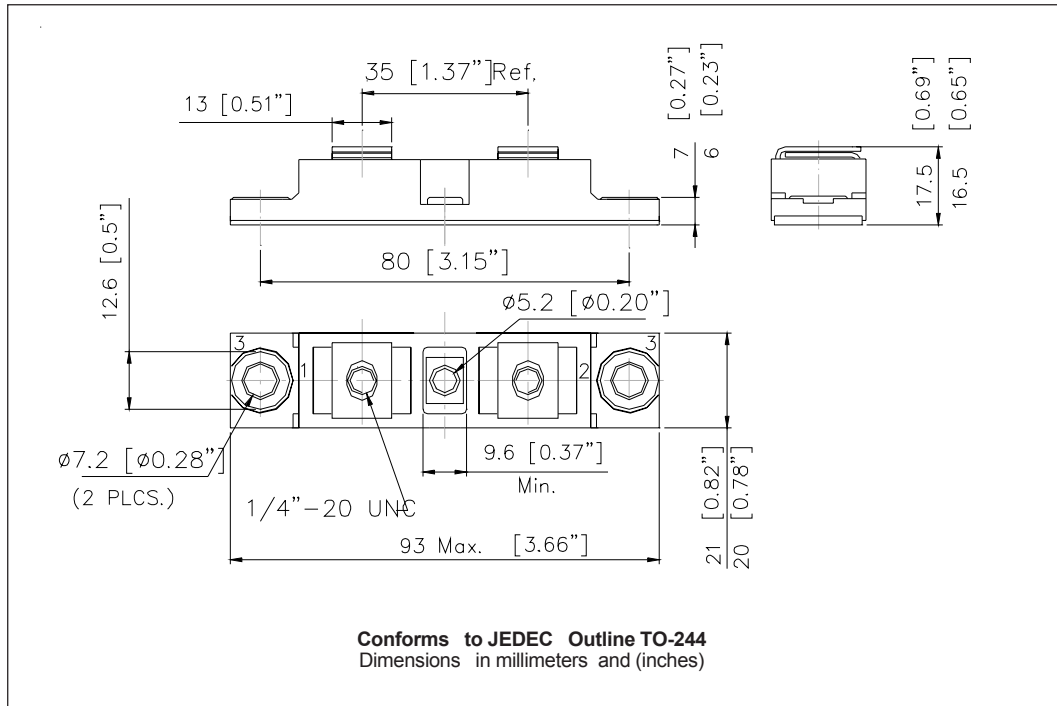

Ordering Information Table

Device Code						
20	9	C	N	Q	150	PbF
①	②	③	④	⑤	⑥	⑦
1	- Average Current Rating (x 10)					
2	- Product Silicon Identification					
3	- C = Circuit Configuration					
4	- N = NOT Isolated					
5	- Q = Schottky Rectifier Diode					
6	- Voltage Ratings				135 = 135V 150 = 150V	
7	- Lead-Free					

209CNQ...PbF Series

Bulletin PD-21106 12/05

International  
**IOR** Rectifier

---

Data and specifications subject to change without notice.  
This product has been designed and qualified for Industrial Level and Lead-Free.  
Qualification Standards can be found on IR's Web site.

International  
**IOR** Rectifier

**IR WORLD HEADQUARTERS:** 233 Kansas St., El Segundo, California 90245, USA Tel: (310) 252-7105  
TAC Fax: (310) 252-7309  
Visit us at [www.irf.com](http://www.irf.com) for sales contact information. 12/05