

**1.8°20mm**

混合式丝杆步进电机参数 Hybrid Linear Stepper Motor



性能规格书 The Performance Specification

Item	Specifications	
电机型号 Model	20HS1402-XXNE	
步距角 Step Angle	1.8°	
绕组类型 Winding Type	2 poles	
相电流 Rated Current ( A )	0.75	
相电阻 Resistance (Ω)	5.8	
功耗 Power Consume(W)	5.7	
转子惯量 Rotor Inertia (g.cm2)	14	
温升 Temperature Rise(°C )	75	

丝杆规格书 The Leadscrew Specification

Φ5				
导程 Helical Pitch		步长 Step Length		步长代码 Step Length Code
in.	mm	in.	mm	
0.07874	2	0.00039	0.01	T

Φ3.5				
导程 Helical Pitch		步长 Step Length		步长代码 Step Length Code
in.	mm	in.	mm	
0.048	1.22	0.0002	0.0061	U
0.096	2.44	0.0004	0.0122	V

The helical pitch can be customized.

**1.8°20mm**

混合式丝杆步进电机参数 Hybrid Linear Stepper Motor

尺寸图 Mechanical Dimensions

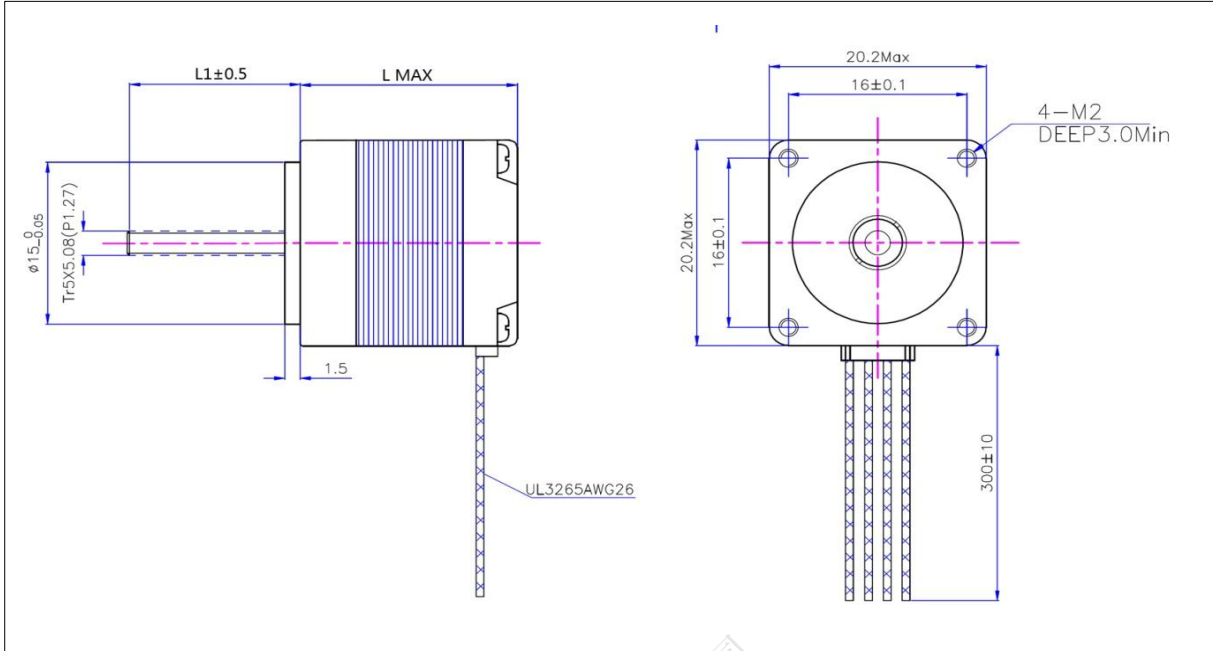

重庆优摩特科技有限公司