

N-Channel MOSFETS

DESCRIPTION

The OGFD 20N50 is produced using advanced planar stripe DMOS technology. This high density process is especially tailored to minimize on-state resistance.

These devices are particularly suited for low voltage application such as cellular phone and notebook computer power management and other battery powered circuits where high-side switching and low in-line power loss are needed in a very small outline surface mount package.

V_{DSS}	$R_{DS(on)}$	I_D
500V	0.26Ω	20A

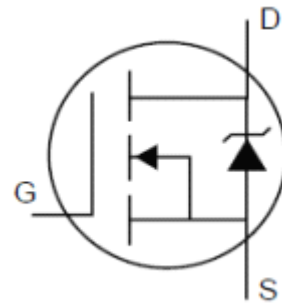

Features

- 20.0A,500V, $R_{DS(ON)}=0.26 \Omega @ V_{GS}=10V$
- Low gate charge (typical 70Nc)
- Fast switching
- 100% avalanche tested
- Improved dv/dt capability

Ordering Information

PART NUMBER	PACKAGE	BRAND
20N50	TO-3P	OGFD

Absolute Maximum Ratings (TC=25°C, unless otherwise noted)

Symbol	Parameter	20N50	Units
V _{DSS}	Drain-to-Source Voltage	500	V
I _D	Continuous Drain Current	20	A
I _{DM}	Pulsed Drain Current@VG=10V	80	
P _D	Power Dissipation	280	W
	Derating Factor above 25°C	2.30	W/°C
V _{GS}	Gate-to-Source Voltage	± 30	V
E _{AS}	Single Pulse Avalanche Energy (L=1mH, I _{AS} =40A)C	1110	mJ
dv/dt	Peak Diode Recovery dv/dt	4.5	V/ns
T _J and T _{STG}	Operating Junction and Storage Temperature Range	-55 to 150	°C

Thermal Resistance

Symbol	Parameter	Min.	Typ.	Max.	Units	Test Conditions
R _{θJC}	Junction-to-Case	--	--	0.44	°C/W	Water cooled heatsink, P _D adjusted for a peak junction temperature of +175°C.
R _{θCS}	Case-to-Sink Typ	--	0.24	--		
R _{θJA}	Junction-to-Ambient	--	--	40		1 cubic foot chamber, free air.

OFF Characteristics T_J=25°C unless otherwise specified

Symbol	Parameter	Min.	Typ.	Max.	Units	Test Conditions
B _V D _{SS}	Drain-to-Source Breakdown Voltage	500	--	--	V	V _{GS} =0, I _D =250uA
I _{GSS}	Gate-to-Source Forward Leakage	--	--	100	nA	V _{DS} =0V, V _{GS} =30V
I _{DSS}	Zero Gate Voltage Drain Current	--	--	1	uA	V _{DS} =500V, V _{GS} =0V

ON Characteristics T_J=25°C unless otherwise specified

Symbol	Parameter	Min.	Typ.	Max	Units	Test Conditions
R _{DS(ON)}	Static Drain-to-Source On-Resistance	--	0.21	0.26	Ω	V _{GS} =10V, I _D =10A
V _{GS(TH)}	Gate Threshold Voltage, Figure 12.	2.0	--	4.0	V	V _{DS} =10V, I _D =250uA

Dynamic Characteristics Essentially independent of operating temperature

Symbol	Parameter	Min.	Typ.	Max.	Units	Test Conditions
C _{iss}	Input Capacitance	--	2700	--	pF	V _{DS} =25V, V _{GS} =0V, f=1.0MHZ
C _{oss}	Output Capacitance	--	400	--		
C _{rss}	Reverse Transfer Capacitance	--	40	340		
Q _g	Total Gate Charge	--	70	--	nC	V _{DS} =400V, V _{GS} =10V, I _D =20A
Q _{gs}	Gate-to-Source Charge	--	18	--		
Q _{gd}	Gate-to-Drain ("Miller") Charge	--	35	--		

Resistive Switching Characteristics Essentially independent of operating temperature

Symbol	Parameter	Min.	Typ.	Max.	Units	Test Conditions
T _{d(ON)}	Turn-on Delay Time		100	--	ns	V _{DD} =250V, I _D = 20.0A R _G =25Ω
T _{rise}	Rise Time		400	--		
T _{d(OFF)}	Turn-Off Delay Time		100	--		
T _{fall}	Fall Time		100	--		

Typical Characteristics

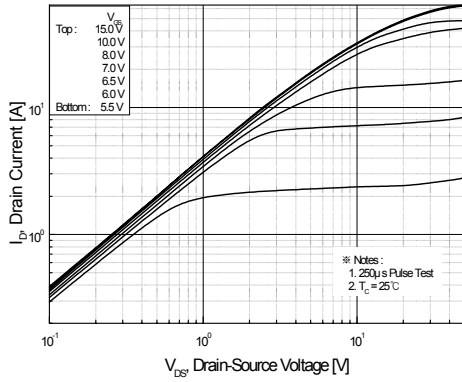

Figure 1. On-Region Characteristics

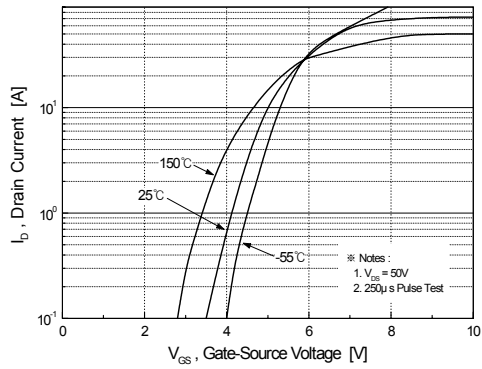

Figure 2. Transfer Characteristics

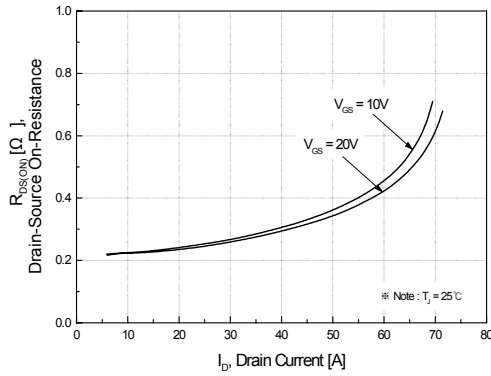

Figure 3. On-Resistance Variation vs

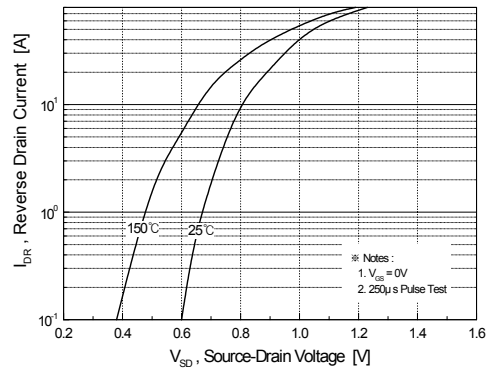

Figure 4. Body Diode Forward Voltage

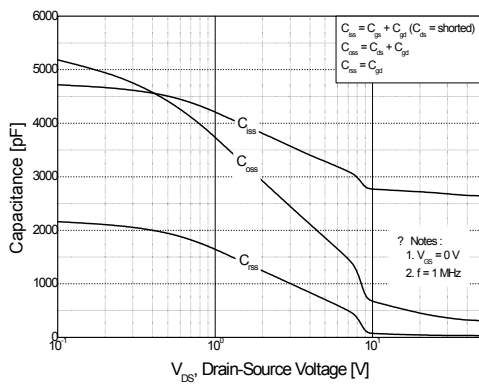

Figure 5. Capacitance Characteristics

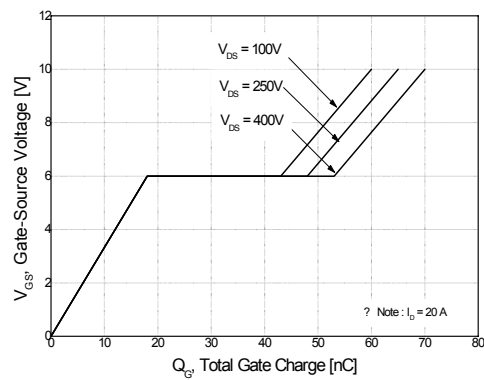

Figure 6. Gate Charge Characteristics

Typical Characteristics (Continued)

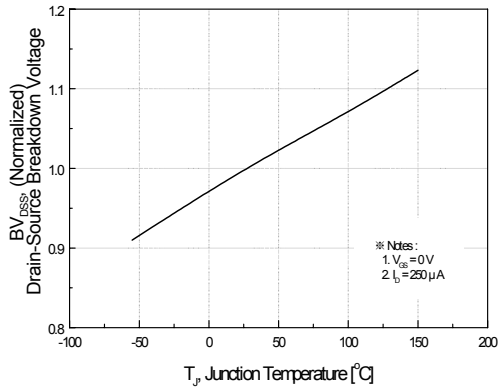

Figure 7. Breakdown Voltage Variation

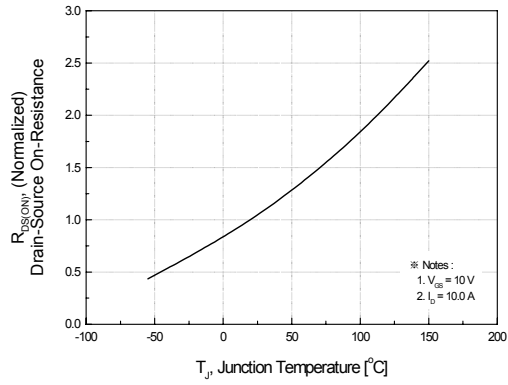

Figure 8. On-Resistance Variation

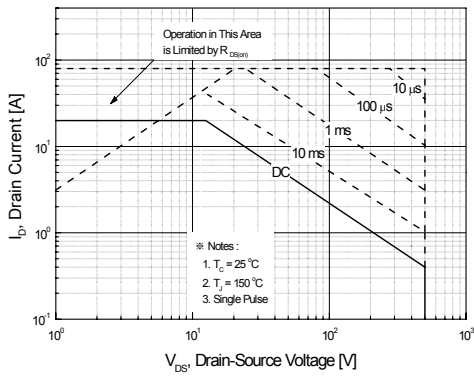

Figure 9. Maximum Safe Operating Area

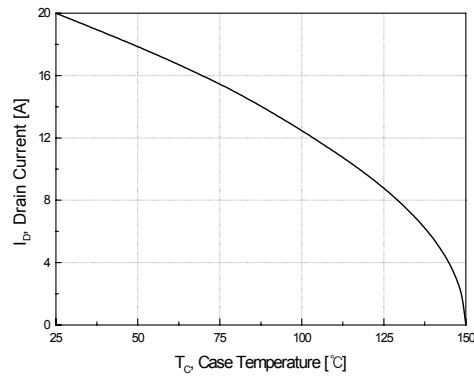

Figure 10. Maximum Drain Current vs Case Temperature

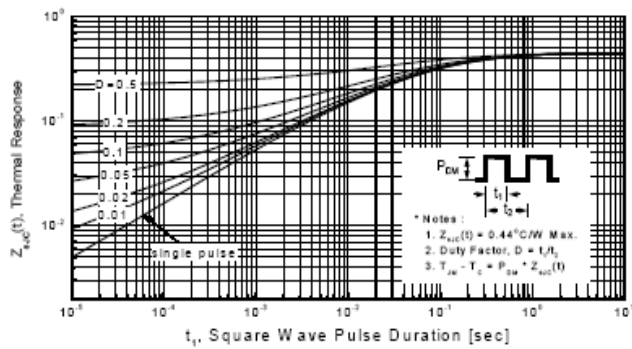
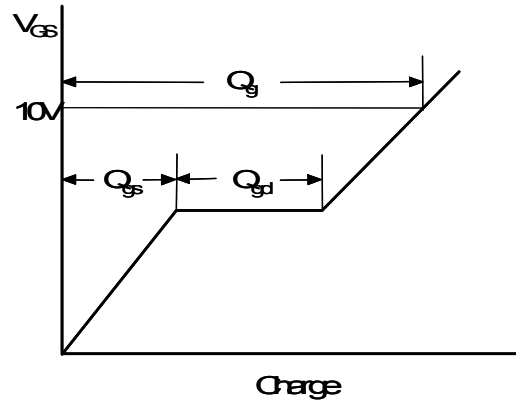
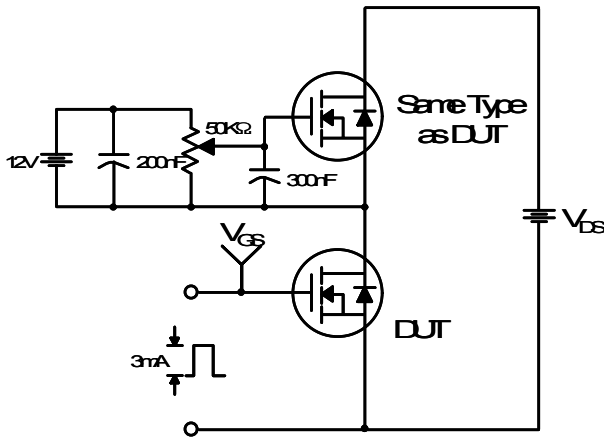
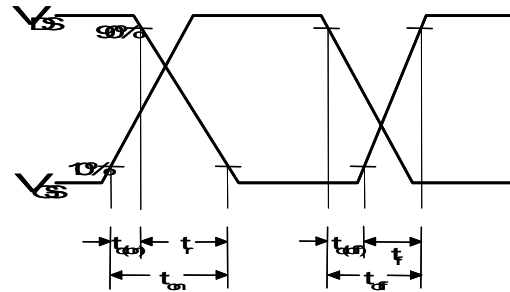
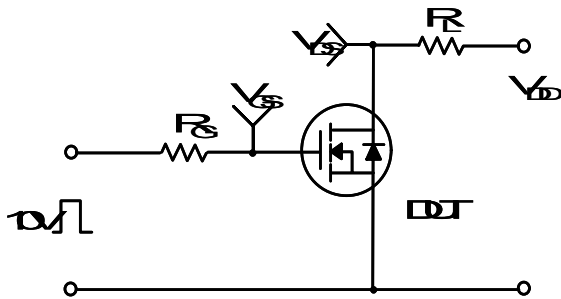

Figure 11. Transient Thermal Response Curve

Gate Charge Test Circuit & Waveform



Resistive Switching Test Circuit & Waveforms



Unclamped Inductive Switching Test Circuit & Waveforms

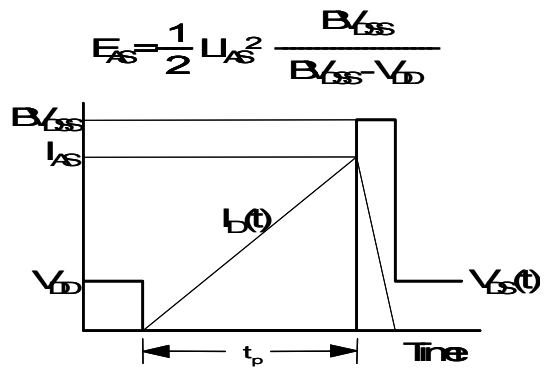
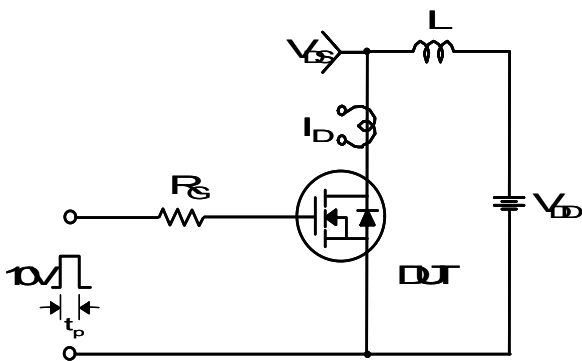

Peak Diode Recovery dv/dt Test Circuit & Waveforms

