

TRIACs, 20A Snubberless

FEATURES

- Medium current triac
- Low thermal resistance with clip bonding
- Low thermal resistance insulation ceramic for insulated TO-220AB & TO-3P package
- Clip assembly
- 20T series are **UL** certified (File ref: E320098)
- Packages are RoHS compliant

APPLICATIONS

The snubberless concept offer suppression of RC network and it is suitable for applications such as phase control and static switching on inductive or resistive load.

Due to their clip assembly technique, they provide a superior performance in surge current handling capabilities.

By using an internal ceramic pad, the 20T series provides voltage insulated tab (rated at 2500VRMS) complying with UL standards.

MAIN FEATURES

SYMBOL	VALUE	UNIT
$I_{T(RMS)}$	20	A
V_{DRM}/V_{RRM}	600 to 1000	V
$I_{GT(Q1)}$	35 to 50	mA

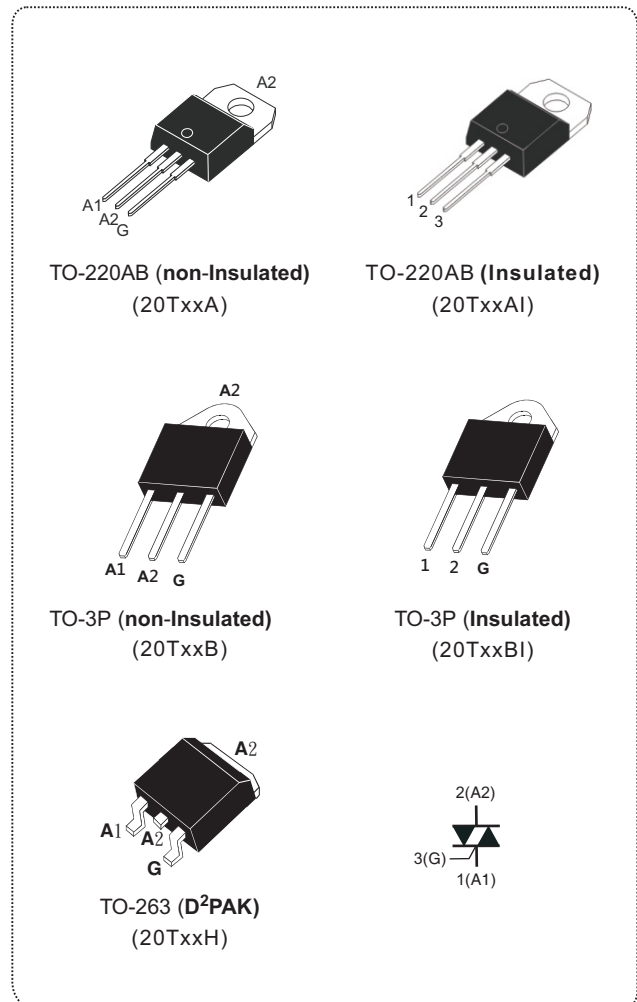

ABSOLUTE MAXIMUM RATINGS					
PARAMETER	SYMBOL	TEST CONDITIONS		VALUE	UNIT
RMS on-state current (full sine wave)	$I_{T(RMS)}$	TO-263/TO-220AB/TO-3P	$T_c = 90^\circ\text{C}$	20	A
		TO-220AB insulated/TO-3P insulated	$T_c = 70^\circ\text{C}$		
Non repetitive surge peak on-state current (full cycle, T_j initial = 25°C)	I_{TSM}	F = 50 Hz	t = 20 ms	200	A
		F = 60 Hz	t = 16.7 ms		
I^2t Value for fusing	I^2t	$t_p = 10$ ms		200	A^2s
Critical rate of rise of on-state current $I_G = 2xI_{GT}$, $t_r \leq 100\text{ns}$	dI/dt	F = 100 Hz	$T_j = 125^\circ\text{C}$	50	$\text{A}/\mu\text{s}$
Peak gate current	I_{GM}	$T_p = 20$ μs	$T_j = 125^\circ\text{C}$	4	A
Peak gate power dissipation ($t_p = 20\mu\text{s}$)	P_{GM}	$T_j = 125^\circ\text{C}$		10	W
Average gate power dissipation	$P_{G(AV)}$	$T_j = 125^\circ\text{C}$		1	
Storage temperature range	T_{stg}			- 40 to + 150	$^\circ\text{C}$
Operating junction temperature range	T_j			- 40 to + 125	

© ELECTRICAL CHARACTERISTICS (T_J = 25 °C unless otherwise specified)

SNUBBERLESS (3 quadrants)						
SYMBOL	TEST CONDITIONS	QUADRANT		20Txxxx		Unit
				CW	BW	
I _{GT} ⁽¹⁾	V _D = 12 V, R _L = 33Ω	I - II - III	MAX.	35	50	mA
V _{GT}		I - II - III	MAX.	1.5		V
V _{GD}	V _D = V _{DRM} , R _L = 3.3KΩ T _j = 125°C	I - II - III	MIN.	0.2		V
I _H ⁽²⁾	I _T = 500 mA		MAX.	40	60	mA
I _L	I _G = 1.2 I _{GT}	I - III	MAX.	50	70	mA
		II		60	80	
dV/dt ⁽²⁾	V _D = 67% V _{DRM} , gate open, T _j = 125°C		MIN.	250	500	V/μs
(dl/dt) ⁽²⁾	(dV/dt) _c = 20 A/ms, T _j = 125°C		MIN.	11	18	A/ms

STATIC CHARACTERISTICS					
SYMBOL	TEST CONDITIONS			VALUE	UNIT
V _{TM} ⁽²⁾	I _{TM} = 28 A, t _P = 380 μs	T _j = 25°C	MAX.	1.55	V
V _{t0} ⁽²⁾	Threshold voltage	T _j = 125°C	MAX.	1.04	V
R _d ⁽²⁾	Dynamic resistance	T _j = 125°C	MAX.	20	mΩ
I _{DRM} I _{RPM}	V _D = V _{DRM} V _R = V _{RRM}	T _j = 25°C	MAX.	5	μA
		T _j = 125°C		2.5	mA

Note 1: Minimum I_{GT} is guaranteed at 5% of I_{GT} max.

Note 2: For both polarities of A2 referenced to A1.

THERMAL RESISTANCE					
SYMBOL				VALUE	UNIT
R _{th(j-c)}	Junction to case (AC)		TO-220AB, TO-263, TO-3P	1.3	°C/W
			TO-220AB Insulated, TO-3P Insulated	2.1	
R _{th(j-a)}	Junction to ambient	S = 1 cm ²	TO-263	45	
			TO-220AB Insulated, TO-220AB	60	
			TO-3P, TO-3P Insulated		

S = Copper surface under tab.

PRODUCT SELECTOR						
PART NUMBER	VOLTAGE (xx)			SENSITIVITY	TYPE	PACKAGE
	600 V	800 V	1000 V			
20TxxA-CW/20TxxAI-CW	V	V	V	35 mA	Snubberless	TO-220AB
20TxxA-BW/20TxxAI-BW	V	V	V	50 mA	Snubberless	TO-220AB
20TxxB-CW/20TxxBI-CW	V	V	V	35 mA	Snubberless	TO-3P
20TxxB-BW/20TxxBI-BW	V	V	V	50 mA	Snubberless	TO-3P
20TxxH-CW	V	V	V	35 mA	Snubberless	D ² PAK
20TxxH-BW	V	V	V	50 mA	Snubberless	D ² PAK

AI: Insulated TO-220AB package

BI: Insulated TO-3P package

ORDERING INFORMATION					
ORDERING TYPE	MARKING	PACKAGE	WEIGHT	BASE Q'TY	DELIVERY MODE
20TxxA-yy	20TxxA-yy	TO-220AB	2.0g	50	Tube
20TxxAI-yy	20TxxAI-yy	TO-220AB (insulated)	2.3g	50	Tube
20TxxB-yy	20TxxB-yy	TO-3P	4.3g	30	Tube
20TxxBI-yy	20TxxBI-yy	TO-3P (insulated)	4.8g	30	Tube
20TxxH-yy	20TxxH-yy	TO-263(D ² PAK)	2.0g	50	Tube

Note: xx = voltage, yy = sensitivity

ORDERING INFORMATION SCHEME

20 T 06 A - BW

Current
20 = 20A

Triac series

Voltage
06 = 600V
08 = 800V
10 = 1000V

Package type
A = TO-220AB (non-insulated)
AI = TO-220AB (insulated)
B = TO-3P (non-insulated)
BI = TO-3P (insulated)
H = TO-263 (D²PAK)

I_{GT} Sensitivity
BW = 50mA Snubberless
CW = 35mA Snubberless

20: Current (20A)

T: Triac series

06: Voltage (600V)

A: Package type (TO-220AB non-insulated)

BW: I_{GT} Sensitivity (50mA Snubberless)

Fig.1 Maximum power dissipation versus RMS on-state current (full cycle)

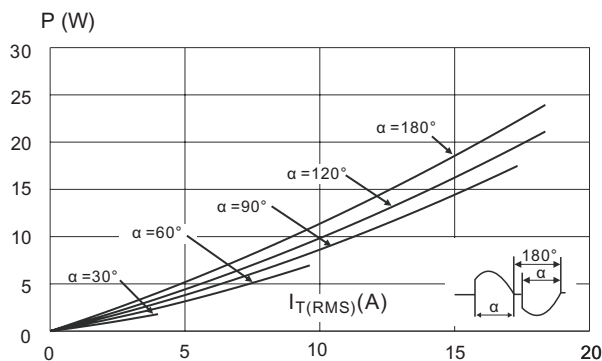

Fig.2 Correlation between maximum RMS power dissipation and maximum allowable temperatures (T_{amb} and T_{case}) for different thermal resistances heatsink + contact

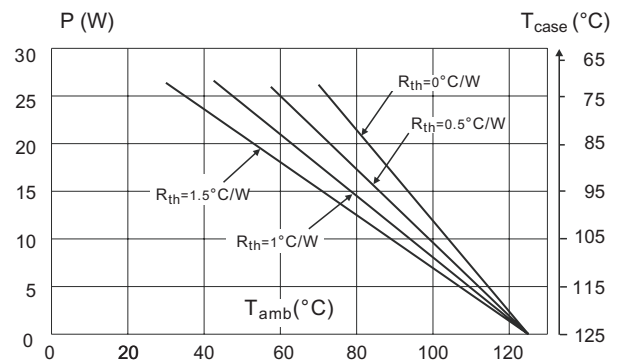

Fig.3 RMS on-state current versus case temperature (full cycle)

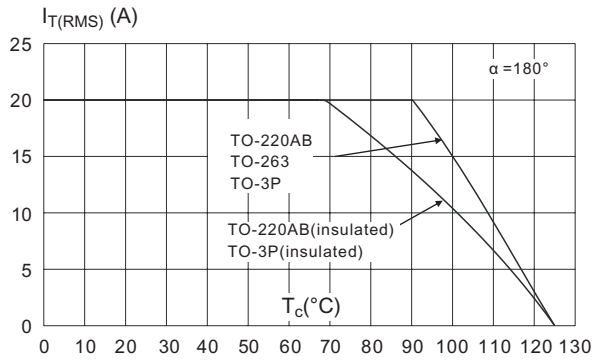

Fig.4 Relative variation of thermal impedance versus pulse duration.

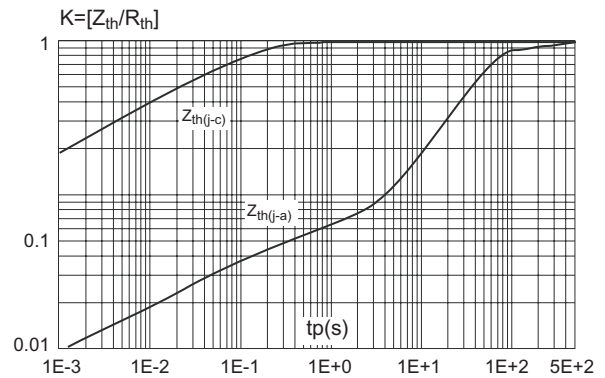

Fig.5 On-state characteristics (maximum values).

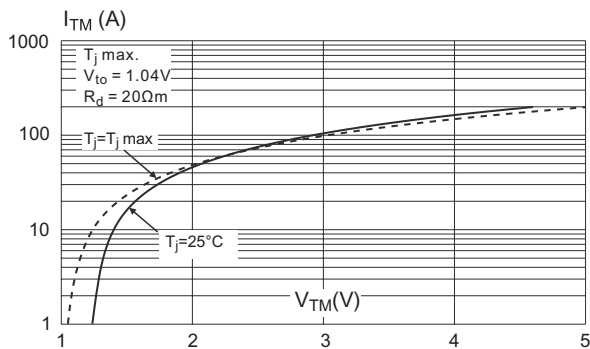

Fig.6 Surge peak on-state current versus number of cycles.

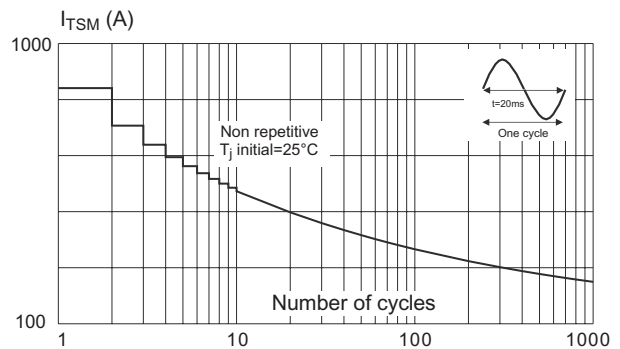

Fig.7 Non-repetitive surge peak on-state current for a sinusoidal pulse with width $t_p < 10ms$. and corresponding value of I^2t .

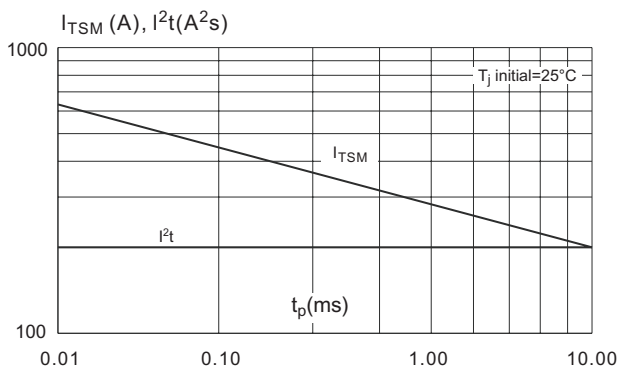
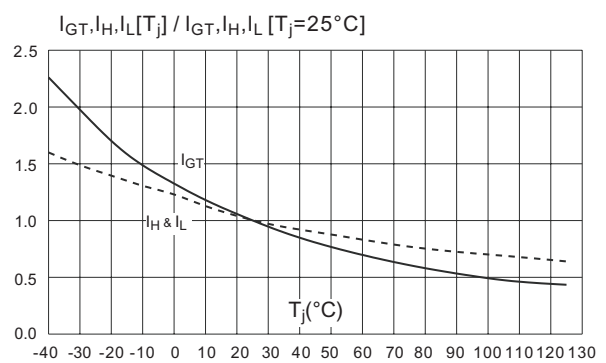
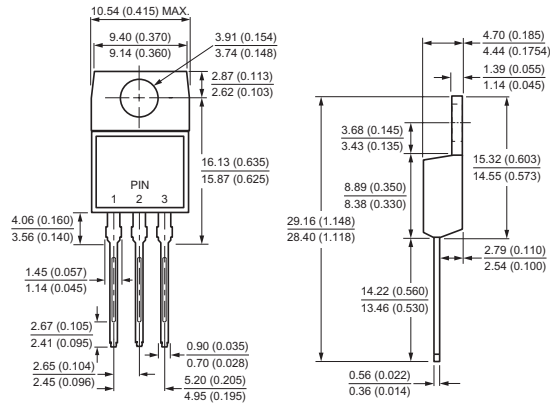

Fig.8 Relative variation of gate trigger current and holding current versus junction temperature.



Case Style

TO-220AB



TO-263(D²PAK)

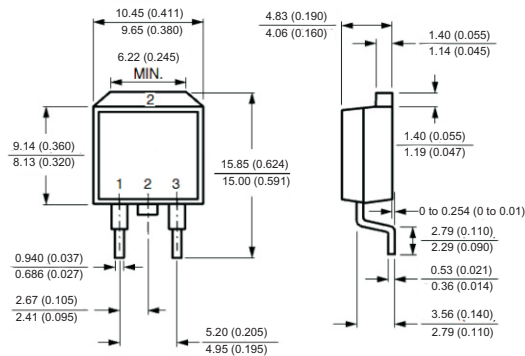

TO-3P

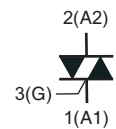
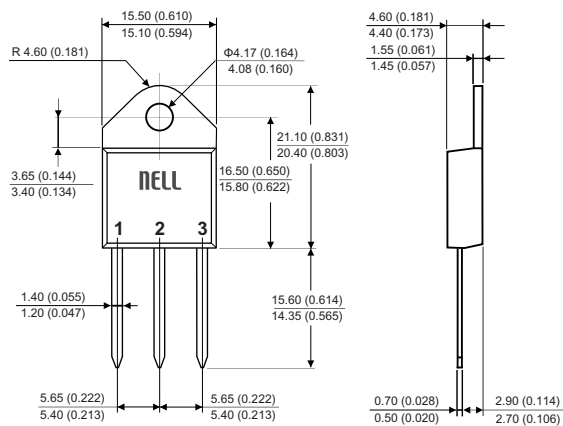

All dimensions in millimeters(inches)