

2445A/2455A OSCILLOSCOPES SERVICE

WARNING

THE FOLLOWING SERVICING INSTRUCTIONS ARE FOR USE BY QUALIFIED PERSONNEL ONLY. TO AVOID PERSONAL INJURY, DO NOT PERFORM ANY SERVICING OTHER THAN THAT CONTAINED IN OPERATING INSTRUCTIONS UNLESS YOU ARE QUALIFIED TO DO SO. REFER TO OPERATORS SAFETY SUMMARY AND SERVICE SAFETY SUMMARY PRIOR TO PERFORMING ANY SERVICE.

*Please Check for
CHANGE INFORMATION
at the Rear of This Manual*

TEKTRONIX MANUAL SCANS

By

Artek Media

1042 Plummer Cir. SW
Rochester, MN 55902

www.artekmedia.com

“Digitally remastered scans of obsolete technical manuals”

**ALL TEKTRONIX MANUALS ARE REPRODUCED
WITH PERMISSION OF
TEKTRONIX INC.**

**Reproduction of this scanned document or removal of this disclaimer
Will be considered in violation of Artek Media's copyrights**

If your looking for a quality scanned technical manuals in PDF format please visit our WEB site at www.artekmedia.com or drop us an email at manuals@artekmedia.com and we will be happy to email you a current list of the manuals we have available.

If you don't see the manual you need on the list, drop us an email anyway we may still be able to point you to other sources. If you have an existing manual you would like scanned please write for details, this can often be done very reasonably in consideration for adding your manual to our library. See the web site for details.

Thanks



Dave & Lynn Henderson
Artek Media

Copyright © 1986 Tektronix, Inc. All rights reserved.
Contents of this publication may not be reproduced in any
form without the written permission of Tektronix, Inc.

Products of Tektronix, Inc. and its subsidiaries are covered
by U.S. and foreign patents and/or pending patents.

TEKTRONIX, TEK, SCOPE-MOBILE, and  are
registered trademarks of Tektronix, Inc.

Printed in U.S.A. Specification and price change privileges
are reserved.

TABLE OF CONTENTS

	Page		Page
	iii		
	iv		
	v		
	vi		
SECTION 1 SPECIFICATION		DAC REF, CH 1 AND CH 2 INPUT CAPACITANCE, AND VERTICAL READOUT JITTER ADJUSTMENTS.....	5-7
INTRODUCTION.....	1-1	AUTOMATIC CALIBRATION CONSTANTS, HORIZONTAL AND VERTICAL GAIN, CENTERING, AND TRANSIENT RESPONSE ADJUSTMENTS.....	5-10
PERFORMANCE CONDITIONS.....	1-1	CAL 01—HORIZONTAL.....	5-10
SECTION 2 OPERATING INFORMATION		CAL 02—VERTICAL.....	5-14
SAFETY	2-1	CAL 03—TRIGGERING	5-15
LINE VOLTAGE SELECTION.....	2-1	CAL 04—CH 2 DELAY ENABLE/DISABLE	5-16
LINE FUSE.....	2-1	CAL 05—Set HRS ON and PWR ON/OFF CYCLES.....	5-17
POWER CORD	2-1	CAL 06—VERTICAL TRANSIENT RESPONSE.....	5-17
INSTRUMENT COOLING.....	2-1	CAL 07—READOUT CENTERING AND GAIN.....	5-20
OPERATING INFORMATION.....	2-1	DYNAMIC CENTERING, DC BALANCE, AND X-Y PHASE DIFFERENTIAL ADJUSTMENTS.....	5-21
START-UP	2-2		
REPACKAGING FOR SHIPMENT ..	2-2		
SECTION 3 THEORY OF OPERATION		SECTION 6 MAINTENANCE	
SECTION 4 PERFORMANCE CHECK AND FUNCTIONAL VERIFICATION PROCEDURE		STATIC-SENSITIVE COMPONENTS ..	6-1
INTRODUCTION	4-1	PREVENTIVE MAINTENANCE.....	6-2
PREPARATION.....	4-1	INTRODUCTION.....	6-2
VERTICAL.....	4-4	GENERAL CARE	6-2
TRIGGERING	4-16	INSPECTION AND CLEANING	6-2
HORIZONTAL	4-21	LUBRICATION.....	6-4
COUNTER/TIMER/TRIGGER CHECKS	4-28	SEMICONDUCTOR CHECKS.....	6-4
HORIZONTAL (cont).....	4-33	PERIODIC READJUSTMENT	6-4
CALIBRATOR, EXTERNAL Z-AXIS AND GATE OUTPUTS.....	4-35	TROUBLESHOOTING.....	6-5
ADDITIONAL FUNCTIONAL VERIFICATION.....	4-37	INTRODUCTION.....	6-5
WORD RECOGNIZER CHECKS	4-39	TROUBLESHOOTING AIDS	6-5
SECTION 5 ADJUSTMENT PROCEDURE		TROUBLESHOOTING EQUIPMENT	6-6
INTRODUCTION.....	5-1	TROUBLESHOOTING TECHNIQUES.....	6-6
POWER SUPPLIES	5-2	DIAGNOSTIC ROUTINES	6-9
CRT ADJUSTMENTS	5-4	CORRECTIVE MAINTENANCE.....	6-20
		INTRODUCTION.....	6-20
		MAINTENANCE PRECAUTIONS....	6-20
		OBTAINING REPLACEMENT PARTS	6-20
		MAINTENANCE AIDS	6-20

TABLE OF CONTENTS (cont)

	Page		
SECTION 6		MAINTENANCE (cont)	
		INTERCONNECTIONS	6-21
		TRANSISTORS, INTEGRATED CIRCUITS, AND HYBRID CIRCUITS	6-22
		SOLDERING TECHNIQUES	6-22
		REMOVAL AND REPLACEMENT INSTRUCTIONS	6-24
SECTION 7		OPTIONS	
		INTRODUCTION	7-1
		POWER CORD OPTIONS.....	7-1
		OPTION 1R	7-1
		OPTION 01	7-1
		OPTION 05	7-2
		OPTIONS 06 and 09.....	7-2
		OPTION 10	7-2
		OPTION 11	7-2
SECTION 8		2445A REPLACEABLE ELECTRICAL PARTS	
SECTION 9		2455A REPLACEABLE ELECTRICAL PARTS	
SECTION 10		DIAGRAMS ACRONYM DICTIONARY	
SECTION 11		2445A REPLACEABLE MECHANICAL PARTS	
SECTION 12		2455A REPLACEABLE MECHANICAL PARTS	

LIST OF ILLUSTRATIONS

Figure		Page
1-1	Dimensional drawing.....	1-21
2-1	Line selector switch, line fuse, and detachable power cord.....	2-2
6-1	Multipin Connector Orientation	6-6
6-2	Ribbon Cable Removal.....	6-26
6-3	Power Switch Push Button Disassembly.....	6-31
10-1	Color codes for resistors and capacitors.	
10-2	Semiconductor lead configurations.	
10-3	Locating components on schematic diagrams and circuit board illustrations.	
10-4	Instrument block diagram.	
10-5	A5—Control board.	
10-6	A6—Front Panel board.	
10-7	A1—Main and A8—Scale Illumination boards.	
10-8	A15—Holdoff board.	
10-9	A14—Dynamic Centering board.	
10-10	A4—Readout board.	
10-11	A9—2455A High Voltage board.	
10-12	A9—2445A High Voltage board.	
10-13	A2—Regulator and A3—Inverter boards.	

LIST OF TABLES

Table		Page
1-1	Electrical Characteristics	1-2
1-2	Option 06 (C/T/T) Electrical Characteristics.....	1-11
1-3	Resolution Selections	1-16
1-4	Resolution Selections	1-16
1-5	Option 09 (WR) Electrical Characteristics	1-17
1-6	Mechanical Characteristics.....	1-18
1-7	Environmental Requirements.....	1-19
2-1	Power Cord and Voltage Data	2-3
4-1	Test Equipment Required.....	4-2
4-2	Accuracy Limits.....	4-8
4-3	Accuracy Limits.....	4-10
4-4	CH 3 and CH 4 Accuracy Limits	4-10
4-5	CH 1 or CH 2 Triggering Conditions	4-17
4-6	CH 3 or CH 4 Triggering Conditions	4-18
4-7	Settings for A and B Timing Accuracy Checks	4-23
4-8	Horizontal Timing Accuracy Checked Against the Graticule.....	4-24
4-9	Delta Time Display Accuracy.....	4-26
4-10	Delayed Sweep Delta Time Accuracy	4-27
4-11	Data Setup Time Checks	4-40
4-12	Data Hold Time Checks.....	4-41
4-13	Minimum Clock Pulse Width Checks	4-41
4-14	Delay From Selected Edge to WORD RECOG OUT Checks	4-42
4-15	Word Recognition Delay.....	4-42
5-1	Power Supply Voltage and Ripple Tolerances.....	5-3
5-2	Horizontal Timing	5-12
5-3	Horizontal Timing	5-13
5-4	Vertical Calibration Signals.....	5-14
5-5	Vertical Calibration Signals.....	5-15
6-1	Susceptibility to Static Discharge Damage.....	6-1
6-2	External Inspection Check List.....	6-2
6-3	Internal Inspection Check List.....	6-3
6-4	Sequence of Diagnostic Tests.....	6-11
6-5	Sequence of Exerciser Routines	6-12
6-6	Kernel Test Failure Codes	6-13
6-7	Front-Panel LED Option Codes.....	6-13
6-8	Front-Panel LED Device Codes.....	6-14
6-9	Potentiometer Codes and Values (Exerciser 01).....	6-16
6-10	Pots and Switches Column and Row Code Definitions	6-17
6-11	NOP Test Data	6-19
6-12	Maintenance Aids	6-21

OPERATORS SAFETY SUMMARY

The general safety information in this part of the summary is for both operating and servicing personnel. Specific warnings and cautions will be found throughout the manual where they apply and do not appear in this summary.

Terms in This Manual

CAUTION statements identify conditions or practices that could result in damage to the equipment or other property.

WARNING statements identify conditions or practices that could result in personal injury or loss of life.

Terms as Marked on Equipment

CAUTION indicates either a personal injury hazard that is not immediately accessible as one reads the markings, or a hazard to property (including the equipment itself).

DANGER indicates a personal injury hazard immediately accessible as one reads the marking.

Symbols in This Manual



This symbol indicates where applicable cautionary or other information is to be found. For maximum input voltage see Table 1-1.

Symbols as Marked on Equipment



DANGER — High voltage.



Protective ground (earth) terminal.



ATTENTION — Refer to manual.

Power Source

This product is intended to operate from a power source that will not apply more than 250 volts rms between the supply conductors or between either supply conductor and ground. A protective ground connection by way of the grounding conductor in the power cord is essential for safe operation.

Grounding the Product

This product is grounded through the grounding conductor of the power cord. To avoid electrical shock, plug the power cord into a properly wired receptacle before making any connections to the product input or output terminals. A protective ground connection by way of the grounding conductor in the power cord is essential for safe operation.

Danger Arising from Loss of Ground

Upon loss of the protective-ground connection, all accessible conductive parts (including knobs and controls that may appear to be insulated) can render an electric shock.

Use the Proper Power Cord

Use only the power cord and connector specified for your product.

Use only a power cord that is in good condition.

For detailed information on power cords and connectors, see Table 2-1.

Use the Proper Fuse

To avoid fire hazard, use only a fuse of the correct type, voltage rating and current rating as specified in the parts list for your product.

Do Not Operate in Explosive Atmospheres

To avoid explosion, do not operate this instrument in an explosive atmosphere unless it has been specifically certified for such operation.

Do Not Remove Covers or Panels

To avoid personal injury, do not remove the product covers or panels. Do not operate the instrument unless the covers and panels are properly installed.

SERVICING SAFETY SUMMARY

FOR QUALIFIED SERVICE PERSONNEL ONLY

Refer also to the preceding Operators Safety Summary.

Do Not Service Alone

Do not perform internal service or adjustment of this product unless another person capable of rendering first aid and resuscitation is present.

Use Care When Servicing With Power On

Dangerous voltages exist at several points in this product. To avoid personal injury, do not touch exposed connections or components while power is on.

Disconnect power before removing protective panels, soldering, or replacing components.

Power Source

This product is intended to operate from a power source that does not apply more than 250 volts rms between the supply conductors or between either supply conductor and ground. A protective ground connection by way of the grounding conductor in the power cord is essential for safe operation.

SPECIFICATION

INTRODUCTION

The TEKTRONIX 2445A and 2455A Oscilloscopes are portable 150-MHz and 250-MHz bandwidth instruments having four-channel vertical deflection systems. Channel 1 and Channel 2 provide calibrated deflection factors from 2 mV per division to 5 V per division. For each of these channels, input impedance is selectable between two values: either 1 M Ω in parallel with 15 pF, or 50- Ω internal termination. Input-signal coupling with 1-M Ω impedance can be selected as either AC or DC. Channel 3 and Channel 4 have deflection factors of either 0.1 V or 0.5 V per division. Each of these channels has an input impedance of 1 M Ω in parallel with 15 pF, with DC input-signal coupling.

The trigger system works automatically for most signals. They operate in various modes, from any channel, with couplings for a wide range of signals. The 2445A trigger system gives stable displays from dc to 250 MHz. The 2455A trigger system gives stable displays from dc to 500 MHz.

The horizontal deflection system provides calibrated sweep speeds from 1.5 s per division to 1 ns per division, including the effects of the X10 magnifier and the calibrated variable between the 1-2-5 steps. Horizontal displays include A Sweep, B Sweep (delayed), A alternated with B, and CH 1 (for X/Y displays).

The AUTO, SAVE, and RECALL features save time and prevent errors. Pressing the AUTO Setup button gives a workable setup for almost any signal. For repetitive measurements, the Save and Recall functions record and immediately or sequentially restore as many as 30 instrument setups. The SETUP buttons operate all instrument functions, including the extended function options.

Direct, on-screen readouts of time measurements, voltage measurements, scale factors, trigger levels, and auxiliary information also save time and improve operator confidence.

The instruments are shipped with the following standard accessories:

- 2 Probe packages
- 1 Snap-lock accessories pouch
- 1 Zip-lock accessories pouch
- 1 Operators manual
- 1 Power cord (installed)
- 1 2-A, 250-V fuse
- 1 Clear plastic CRT filter
- 1 Blue plastic CRT filter (installed)
- 1 Front-panel cover
- 1 Operators pocket reference card

For part numbers and further information about both standard and optional accessories, refer to "Options and Accessories" (Section 7) of the instrument's Operators manual or the Accessories information at the rear of this manual. Your Tektronix representative or local Tektronix Field Office can also provide accessories information and ordering assistance.

PERFORMANCE CONDITIONS

The following electrical characteristics (Tables 1-1 through 1-5) are valid for the instrument when it has been adjusted at an ambient temperature between +20°C and +30°C, has had a warm-up period of at least 20 minutes, and is operating at an ambient temperature between -15°C and +55°C (unless otherwise noted).

Items listed in the "Performance Requirements" column define the measurement capabilities of the instruments. Supplementary measurement conditions may also be listed in the "Performance Requirements" column.

Mechanical characteristics are listed in Table 1-6.



Environmental characteristics are given in Table 1-7. The oscilloscope meets the environmental requirements of MIL-T-28800C for Type III, Class 3, Style C equipment, with the humidity and temperature requirements defined in paragraphs 3.9.2.2, 3.9.2.3, and 3.9.2.4.

Table 1-1
2445A-2455A Electrical Characteristics

Characteristics	Performance Requirements
VERTICAL DEFLECTION SYSTEM—CHANNEL 1 AND CHANNEL 2	
Deflection Factor	
Range	2 mV/division to 5 V/division in a 1-2-5 sequence of 11 steps.
Accuracy	1 M Ω input, noninverted.
+15°C to +35°C	
On-Graticule Accuracy	Within $\pm 2\%$ at any VOLTS/DIV setting for a four or five-division signal centered on the screen.
ΔV Accuracy (using cursors over entire graticule area)	$\pm (1.25\%$ of reading + 0.03 div + signal aberrations).
-15°C to +15°C and +35°C to +55°C	Add $\pm 2\%$ of reading. ^a
50 Ω Coupling	Add $\pm 1\%$ of reading.
CH 2 Inverted	Add $\pm 1\%$ of reading.
ΔV Range	$\pm 8 \times$ VOLTS/DIV setting. ^a
V/DIV VARIABLE, noninverted	Continuously variable between VOLTS/DIV settings. Extends deflection factor to >12.5 V/division.
Frequency Response	<p>Bandwidth is measured with a leveled, low distortion, 50-Ω source, sine-wave generator, terminated in 50 Ω. The reference signal amplitude is set at the lesser of 6 divisions or the maximum leveled amplitude.</p> <p>Bandwidth with probe is checked using a probe-tip-to-GR (017-0520-00) termination adapter.</p> <p>Bandwidth with external termination is checked using a BNC 50 Ω feed-through terminator (011-0049-01).</p>
-3 dB Bandwidth	Using standard accessory probe or internal 50- Ω termination.
2455A	
+15°C to +35°C	Dc to 250 MHz.
-15°C to +15°C and +35°C to +55°C	Dc to 200 MHz. ^a
2445A	Dc to 150 MHz.
-4.7 dB Bandwidth	Using 50- Ω external termination on 1-M Ω input.
2455A	
-15°C to +35°C	Dc to 250 MHz.
+35°C to +55°C	Dc to 200 MHz.
2445A	Dc to 150 MHz.

^aPerformance requirements not checked in manual.

Table 1-1 (cont)

Characteristics	Performance Requirements
AC Coupled, Lower –3 dB Frequency With Standard Accessory Probe	10 Hz or less. ^a 1 Hz or less.
Step Response Rise Time 2455A	Calculated from $T_r = 0.35/BW$. ^a ≤1.4 ns.
2445A	≤2.33 ns.
Channel Isolation	≥100:1 attenuation of deselected channel at 100 MHz; ≥50:1 at 350 MHz, for an eight-division input signal from 2 mV per division to 500 mV per division, with equal VOLTS/DIV settings on both channels.
Displayed Channel 2 Signal Delay with Respect to Channel 1 Signal	Adjustable through a range of at least –500 ps to +500 ps. ^a
Input R and C (1 MΩ) Resistance	1 MΩ ±0.5%. ^a
Capacitance	15 pF ±2 pF. ^a
Maximum Input Voltage  DC, AC, or GND Coupled	400 V (dc + peak ac). 800 V p-p ac at 10 kHz or less. ^a
Input R (50 Ω) Resistance	50 Ω ±1%. ^a
VSWR	≤1:3:1 for dc to Nominal Bandwidth.
Maximum Input Voltage 	5 V rms, averaged for 1 second; ±50 V peak.
Cascaded Operation	Channel 2 Vertical Signal Output into Channel 1 input; DC coupled using a 50 Ω RG-58C/U coaxial cable, terminated in 50 Ω at the Channel 1 input. Channel 1 and Channel 2 VOLTS/DIV set at 2 mV and Bandwidth Limit On.
Deflection Factor	400 μV per division ±10%.
CMRR (ADD Mode with Channel 2 inverted)	At least 20:1 at 50 MHz for common-mode signals of eight divisions or less, with VAR VOLTS/DIV control adjusted for best CMRR at 50 kHz, at any VOLTS/DIV setting.

^aPerformance requirement not checked in manual.

Table 1-1 (cont)

Characteristics	Performance Requirements
VERTICAL DEFLECTION SYSTEM—CHANNEL 3 AND CHANNEL 4	
Deflection Factors Values	100 mV and 500 mV per division.
Accuracy	Within $\pm 10\%$.
Frequency Response	Bandwidth is measured with a leveled, low distortion, 50- Ω source, sine-wave generator, terminated in 50 Ω . The reference signal amplitude is set at the lesser of 6 divisions or the maximum leveled amplitude. Bandwidth with probe is checked using a probe-tip-to-GR (017-0520-00) termination adapter. Bandwidth with external termination is checked using a BNC 50- Ω feed-through terminator (011-0049-01).
-3 dB Bandwidth 2455A +15°C to +35°C	Using standard accessory probe. Dc to 250 MHz.
-15°C to +15°C and +35°C to +55°C	Dc to 200 MHz. ^a
2445A	Dc to 150 MHz.
-4.7 dB Bandwidth 2455A +15°C to +35°C	Using 50- Ω external termination. Dc to 250 MHz. ^a
-15°C to +15°C	Dc to 200 MHz and +35°C to +55°C. ^a
2445A	Dc to 150 MHz. ^a
Step Response Rise Time 2455A	Calculated from $T_r = 0.35/BW$. ≤ 1.4 ns.
2445A	≤ 2.33 ns.
Channel Isolation	$\geq 50:1$ attenuation of deselected channel at 100 MHz with an 8-division input signal.
Signal Delay Between Channel 1 and Either Channel 3 or Channel 4	Within ± 1.0 ns, measured at the 50% points. ^a
Input Resistance	1 M Ω $\pm 1\%$. ^a
Input Capacitance	15 pF ± 3 pF. ^a
Maximum Input Voltage 	400 V (dc + peak ac). 800 V p-p ac at 10 kHz or less. ^a

^aPerformance requirements not checked in manual.

Table 1-1 (cont)

Characteristics	Performance Requirements
VERTICAL DEFLECTION SYSTEM—ALL CHANNELS	
Low-frequency Linearity	0.1 division or less compression or expansion of a two-division, center-screen signal when positioned anywhere within graticule area.
Bandwidth Limiter	Reduces upper 3 dB bandpass to a limit of 13 MHz to 24 MHz.
Vertical Signal Delay	At least 30 ns of the sweep is displayed before the triggering event is displayed at any SEC/DIV ≥ 10 ns/div. At 5 ns/div, at least 10 ns of the sweep is displayed before the triggering event. ^a
Chopped Mode Switching Rate	With displayed SEC/DIV in the 20 μ s to 2 μ s/div range, the switching rate is 2.5 MHz $\pm 0.2\%$. Otherwise, the switching rate is 1 MHz $\pm 0.2\%$. The display cycle rate equals the chop switching rate divided by the number of channels displayed. The chop switching rate is modulated slightly to minimize waveform breaks with repetitive signals. ^a
TRIGGERING	
Minimum P-P Signal Amplitude for Stable Triggering from Channel 1 or Channel 2 Source	
2455A	
DC Coupled	0.35 division from dc to 50 MHz; increasing to 1.0 division at 300 MHz and 1.5 divisions at 500 MHz.
NOISE REJ Coupled	≤ 1.2 divisions from dc to 50 MHz; increasing to 3 divisions at 300 MHz and 4.5 divisions at 500 MHz.
AC Coupled	0.35 division from 60 Hz to 50 MHz; increasing to 1.0 division at 300 MHz and 1.5 divisions at 500 MHz. Attenuates signals below 60 Hz.
HF REJ Coupled	0.5 division from dc to 30 kHz.
LF REJ Coupled	0.5 division from 80 kHz to 50 MHz; increasing to 1.0 division at 300 MHz and 1.5 divisions at 500 MHz.
2445A	
DC Coupled	0.35 division from dc to 50 MHz; increasing to 1.5 divisions at 250 MHz.
NOISE REJ Coupled	≤ 1.2 divisions from dc to 50 MHz; increasing to 4.5 divisions at 250 MHz.
AC Coupled	0.35 division from 60 Hz to 50 MHz; increasing to 1.5 divisions at 250 MHz. Attenuates signals below 60 Hz.
HF REJ Coupled	0.5 division from dc to 30 kHz.
LF REJ Coupled	0.50 division from 80 kHz to 50 MHz; increasing to 1.5 divisions at 250 MHz.

^aPerformance requirement not checked in manual.

Table 1-1 (cont)

Characteristics	Performance Requirements
Minimum P-P Signal Amplitude for Stable Triggering from ADD Source	Add 0.5 division to CH 1 or CH 2 requirement at 300 MHz and 500 MHz for 2455A.
Minimum P-P Signal Amplitude for Stable Triggering from CH 3 or CH 4 Source	0.5 X CH 1 or CH 2 requirement. ^a
Minimum P-P Signal Amplitude for Stable Triggering from Composite, Multiple Channel Source, ALT Vertical Mode	Add 1 division to the single-channel source specification. Checked at 50 mV per division.
Maximum P-P Signal Rejected by NOISE REJ COUPLING Signals Within the Vertical Bandwidth CH 1 or CH 2 SOURCE	≥0.4 division for VOLTS/DIV settings of 10 mV/div and higher. Maximum noise amplitude rejected is reduced at 2 mV/div and 5 mV/div.
CH 3 or CH 4 SOURCE	≥0.2 division. ^a
Jitter 2455A	≤50 ps with 5 divisions of 250 MHz at 1 ns/division.
2445A	≤100 ps with 5 divisions of 150 MHz at 1 ns/division.
LEVEL Control Range CH 1 or CH 2 SOURCE	±18 X VOLTS/DIV setting. ^a
CH 3 or CH 4 SOURCE	±9 X VOLTS/DIV setting. ^a
LEVEL Readout Accuracy CH 1 or CH 2 SOURCE +15°C to +35°C	For triggering signals with transition times greater than 20 ns. Within ±[3% of setting + 3% of p-p signal + 0.2 division + 0.5 mV + (0.5 mV X probe attenuation factor)] with Vertical Input at 1 MΩ DC, CH 2 Source Not Inverted, and Trigger DC Coupled.
-15°C to +35°C and +35°C to +55°C	Add 1.5 mV X probe attenuation to +15°C to +35°C specification. ^a
50 Ω Input	Add ±1% to 1 MΩ input specification. ^a
CH 2 Inverted	Add ±1% of setting to non-inverted specification. ^a
NOISE REJ Coupled	Add ±0.6 division to DC Coupled specifications. ^a
CH 3 or CH 4 SOURCE	Within ±[3% of setting + 4% of p-p signal + 0.1 division + (0.5 mV X probe attenuation factor)] and Trigger DC Coupled. ^a
NOISE REJ Coupled	Add ±0.3 division to the DC Coupled specification. ^a

^aPerformance requirement not checked in manual.

Table 1-1 (cont)

Characteristics	Performance Requirements
AUTO LVL Mode Maximum Triggering Signal Period	
A SEC/DIV Setting	
<10 ms	At least 20 ms. ^a
10 ms to 50 ms	At least four times the A-SEC/DIV setting. ^a
>50 ms	At least 200 ms. ^a
AUTO Mode Maximum Triggering Signal Period	
A-SEC/DIV Setting	
<10 ms	At least 80 ms. ^a
10 ms to 50 ms	At least 16 times the A-SEC/DIV setting.
>50 ms	At least 800 ms.
AUTO LVL Mode Trigger Acquisition Time	Eight to 100 times the AUTO LVL Mode maximum triggering signal period, depending on the triggering signal period and waveform.
Trigger Holdoff	
Minimum	The greater of the A-SEC/DIV setting value or 2 μ s, within +33% to -10%, except 1 μ s at 5 ns/div. ^a
Variable	Increases trigger holdoff time to 10 to 25 times the minimum holdoff.
SLOPE Selection	Conforms to trigger-source waveform or ac power-source waveform.
HORIZONTAL DEFLECTION SYSTEM	
A Sweep Time Base Range	500 ms/div to 10 ns/div in a 1-2-5 sequence of 24 steps. X10 MAG extends maximum sweep rate to 1 ns/div.
B Sweep Time Base Range	50 ms/div to 10 ns/div in a 1-2-5 sequence of 21 steps. X10 MAG extends maximum sweep rate to 1 ns/div.
Timing Accuracy	+15°C to +35°C, A Sweep, with SEC/DIV at 100 ms/div or faster.
Sweep Accuracy Unmagnified	$\pm(0.7\%$ of time interval + 0.6% of full scale).
Δt Accuracy With Cursors, Unmagnified	$\pm(0.5\%$ of time interval + 0.3% of full scale).
Δt Accuracy with Sweep Delay	$\pm(0.3\%$ of time interval + 0.1% of full scale).
Delay Accuracy, A-Sweep Trigger to Start of B Sweep	$\pm(0.3\%$ of delay setting + 0.6% of full scale) +0 to -25 ns.
B-Sweep Accuracy and Δt Accuracy with Cursors on B Sweep	Add $\pm 0.3\%$ of time interval to A-Sweep specifications.

^aPerformance requirement not checked in manual.

Table 1-1 (cont)

Characteristics	Performance Requirements
X10 MAG Accuracy	Add $\pm 0.5\%$ of time interval to unmagnified Sweep and Δt Cursors specifications. Exclude the first 0.5 division after the sweep starts (the first 0.5% of the full 100 division sweep).
500 ms or 200 ms/div Timing Accuracy (A Sweep only)	Add $\pm 0.5\%$ of interval to specifications for A SEC/DIV at 100 ms or faster.
SEC/DIV VAR Timing Accuracy	Add 2% of time interval to sweep accuracy specifications when VAR is out of detent.
Timing Accuracy (-15°C to $+15^{\circ}\text{C}$ and $+35^{\circ}\text{C}$ to $+55^{\circ}\text{C}$)	Add $\pm 0.2\%$ of time interval to all Δt and delay specifications. Add $\pm 0.5\%$ of interval to sweep accuracy specification. ^a
Δt Readout Resolution	Greater of either 20 ps or 0.25% of full scale. ^a
Δt Range	± 10 times A-SEC/DIV setting with Cursors, ± 9.95 times A-SEC/DIV setting with Sweep Delay. ^a
Sweep Delay Range	0 to 9.95 times the A SEC/DIV setting, from 500 ms to 20 ns. A-Sweep triggering event is observable on B Sweep with zero delay setting for A SEC/DIV settings 50 μs or faster. ^a
Delay Jitter	Within 0.004% (one part or less in 25,000) of the maximum available delay, plus 50 ps. ^a
Horizontal POSITION Range	Start of 1 ms per division sweep can be positioned from right of graticule center to at least 10 divisions left of graticule center. Some portion of 1 ms per division sweep is always visible with X10 MAG off. ^a
X-Y Operation X-Axis Deflection Factor Range, Variable, and Input Characteristics	Same as Channel 1. ^a
Deflection Factor Accuracy	Same as Channel 1.
X-Axis Bandwidth	Dc to 3 MHz.
Phase Difference Between X and Y with BW Limit Off	$\leq 1^{\circ}$ from dc to 1 MHz; $\leq 3^{\circ}$ from 1 MHz to 2 MHz.
X-Axis Low-frequency Linearity	0.1 division or less compression or expansion of a two-division, center-screen signal when positioned within the graticule area.

^aPerformance requirement not checked in manual.

Table 1-1 (cont)

Characteristics	Performance Requirements
DISPLAY	
Cursor Position Range Delta Volts (ΔV)	At least the center 7.6 vertical divisions. ^a
Delta Time (Δt)	At least the center 9.6 horizontal divisions. ^a
Graticule Size	80 mm X 100 mm. ^a
Markings	8 major divisions vertically and 10 major divisions horizontally, with auxiliary markings. ^a
Trace Rotation Range	Adequate to align trace with the center horizontal graticule line.
Z-AXIS INPUT	
Sensitivity Dc to 2 MHz	Positive voltage decreases intensity; +2 V blanks a maximum intensity trace.
2 MHz to 20 MHz	+2 V modulates a normal intensity trace. ^a
Input Resistance	9 k Ω \pm 10%. ^a
Maximum Input Voltage 	\pm 25 V peak; 25 V p-p ac at 10 kHz or less. ^a
SIGNAL OUTPUTS	
CALIBRATOR Output Voltage and Current	With A SEC/DIV set to 1 ms. 0.4 V \pm 1% into a 1-M Ω load, 0.2 V \pm 1.5% into a 50- Ω load, or 8 mA \pm 1.5% into a short circuit. ^a
Repetition Period	Two times the A SEC/DIV setting for SEC/DIV from 100 ns to 100 ms.
Accuracy	\pm 0.1% during sweep time.
CH 2 SIGNAL OUT Output Voltage	20 mV/division \pm 10% into 1 M Ω ; 10 mV/division \pm 10% into 50 Ω .
Offset	\pm 20 mV into 1 M Ω when dc balance has been performed within \pm 5°C of the operating temperature.
A GATE OUT and B GATE OUT Output Voltage	2.4 V to 5 V positive-going pulse, starting at 0 V to 400 mV.
Output Drive	Will supply 400 μ A during HI state; will sink 2 mA during LO state. ^a

^aPerformance requirement not checked in manual.

Table 1-1 (cont)

Characteristics	Performance Requirements
AC POWER SOURCE	
Source Voltage Nominal Ranges 115 V	90 V to 132 V.
230 V	180 V to 250 V.
Source Frequency	48 Hz to 440 Hz. ^a
Fuse Rating	2 A, 250 V, AGC/3AG, Fast blow; or 1.6 A, 250 V, 5 X 20 mm Quick-acting. ^a
Maximum Power Consumption (fully optioned instrument)	120 watts (180 VA). ^a
Primary Circuit Dielectric Voltage Withstand Test	1500 V rms, 60 Hz for 10 seconds without breakdown. ^a
Primary Grounding	Type test to 0.1 Ω maximum. Routine test to check grounding continuity between chassis ground and protective earth ground.

^aPerformance requirement not checked in manual.

**Table 1-2
Option 06 (C/T/T) Electrical Characteristics**

Characteristics	Performance Requirements																						
SIGNAL INPUT																							
	With DC Coupling of A Trigger and B Trigger.																						
Maximum Input Frequency for Count and Delay by Events	≥ 150 MHz.																						
Minimum Width of High or Low State of Input Signal for Count and Delay by Events	≤ 3.3 ns.																						
Sensitivity	For Count, Delay by Events, and Logic Trigger Functions Excluding Word Recognizer.																						
Dc to 50 MHz (0.5 Hz to 50 MHz for Frequency and Period)																							
CH 1 and CH 2	1.5 divisions.																						
CH 3 and CH 4	0.75 division.																						
50 MHz to 150 MHz																							
CH 1 and CH 2	4.0 divisions.																						
CH 3 and CH 4	2.0 divisions.																						
FREQUENCY																							
Ranges	<table style="width: 100%; border-collapse: collapse;"> <thead> <tr> <th style="text-align: left;">RANGE</th> <th style="text-align: left;">LSD^a</th> </tr> </thead> <tbody> <tr><td>1 Hz</td><td>100 nHz</td></tr> <tr><td>10 Hz</td><td>1 μHz</td></tr> <tr><td>100 Hz</td><td>10 μHz</td></tr> <tr><td>1 kHz</td><td>100 μHz</td></tr> <tr><td>10 kHz</td><td>1 mHz</td></tr> <tr><td>100 kHz</td><td>10 mHz</td></tr> <tr><td>1 MHz</td><td>100 mHz</td></tr> <tr><td>10 MHz</td><td>1 Hz</td></tr> <tr><td>100 MHz</td><td>10 Hz</td></tr> <tr><td>150 MHz</td><td>100 Hz</td></tr> </tbody> </table>	RANGE	LSD ^a	1 Hz	100 nHz	10 Hz	1 μHz	100 Hz	10 μHz	1 kHz	100 μHz	10 kHz	1 mHz	100 kHz	10 mHz	1 MHz	100 mHz	10 MHz	1 Hz	100 MHz	10 Hz	150 MHz	100 Hz
RANGE	LSD ^a																						
1 Hz	100 nHz																						
10 Hz	1 μHz																						
100 Hz	10 μHz																						
1 kHz	100 μHz																						
10 kHz	1 mHz																						
100 kHz	10 mHz																						
1 MHz	100 mHz																						
10 MHz	1 Hz																						
100 MHz	10 Hz																						
150 MHz	100 Hz																						
Automatic Ranging	<p>Upgrades at 100% of full scale; downranges at 9% of full scale. Downrange occurs at 90 MHz on 150 MHz range.</p> <p>Full scale corresponds to the value given in the Range column. The maximum displayed value for any range is the Range value minus the LSD value.</p>																						
Accuracy	±[Resolution + (Frequency × TBE)] Hz.																						
Time Base Error (TBE)	10 ppm with less than 5 ppm per year drift.																						
Resolution	$\frac{1.4 \times \text{Frequency}^2 \times \text{TJE}}{N} + \text{LSD}.$																						
Display Update Rate	Twice per second or twice the period of the input signal, whichever is slower.																						

^aPerformance requirement not checked in manual.

Table 1-2 (cont)

Characteristics	Performance Requirements																						
PERIOD																							
Ranges	<table border="1" style="width: 100%; border-collapse: collapse;"> <thead> <tr> <th style="text-align: center;">RANGE</th> <th style="text-align: center;">LSD^a</th> </tr> </thead> <tbody> <tr> <td style="text-align: center;">10 ns</td> <td style="text-align: center;">1 fs</td> </tr> <tr> <td style="text-align: center;">100 ns</td> <td style="text-align: center;">10 fs</td> </tr> <tr> <td style="text-align: center;">1 μs</td> <td style="text-align: center;">100 fs</td> </tr> <tr> <td style="text-align: center;">10 μs</td> <td style="text-align: center;">1 ps</td> </tr> <tr> <td style="text-align: center;">100 μs</td> <td style="text-align: center;">10 ps</td> </tr> <tr> <td style="text-align: center;">1 ms</td> <td style="text-align: center;">100 ps</td> </tr> <tr> <td style="text-align: center;">10 ms</td> <td style="text-align: center;">1 ns</td> </tr> <tr> <td style="text-align: center;">100 ms</td> <td style="text-align: center;">10 ns</td> </tr> <tr> <td style="text-align: center;">1 s</td> <td style="text-align: center;">100 ns</td> </tr> <tr> <td style="text-align: center;">2 s</td> <td style="text-align: center;">1 μs</td> </tr> </tbody> </table>	RANGE	LSD ^a	10 ns	1 fs	100 ns	10 fs	1 μs	100 fs	10 μs	1 ps	100 μs	10 ps	1 ms	100 ps	10 ms	1 ns	100 ms	10 ns	1 s	100 ns	2 s	1 μs
RANGE	LSD ^a																						
10 ns	1 fs																						
100 ns	10 fs																						
1 μs	100 fs																						
10 μs	1 ps																						
100 μs	10 ps																						
1 ms	100 ps																						
10 ms	1 ns																						
100 ms	10 ns																						
1 s	100 ns																						
2 s	1 μs																						
Minimum Period	≤6.7 ns.																						
Automatic Ranging	Upranges at 100% of full scale; downranges at 9% of full scale. Full scale corresponds to the value given in the Range column. The maximum displayed value for any range is the Range value minus the LSD value.																						
Accuracy	±[Resolution + (TBE × Period)].																						
Resolution	±[LSD + (1.4 × TJE)/N].																						
Display Update Rate	Twice per second or twice the period of the input signal, whichever is slower.																						
TOTALIZE																							
Maximum Count	9999999.																						
Display Update Rate	Twice per second or once per event, whichever is slower.																						
DELAY BY EVENTS																							
Maximum Event Count	4194303.																						
Minimum Time from Start Signal to Any Delay Event	4 ns.																						
LOGIC TRIGGER																							
Minimum Function-True Time	4 ns.																						
Minimum Function-False Time	4 ns.																						

^aPerformance requirement not checked in manual.

Table 1-2 (cont)

Characteristics	Performance Requirements
ADDED DELAY TIME CHARACTERISTICS WITH C/T/T	
<p>Run After Delay</p> <p>Accuracy</p>	<p>$LSD^b + [0.0012 \times (A \text{ SEC/DIV})] + [0.03 \times (B \text{ Time/Div})^c + A \text{ Trigger Level Error} + 50 \text{ ns.}^a$</p> <p>When the A Sweep is triggered by the Word Recognizer in synchronous mode, add 100 ns for probe delay; in asynchronous mode, add 200 ns for probe delay.</p>
<p>Triggerable After Delay</p> <p>Accuracy</p>	<p>For intervals within 70 ns to 10 times the A-SEC/DIV Setting.</p> <p>$LSD^b + [10 \text{ ppm} \times (\text{measured interval})] + TJE + A\text{-Trigger Level Error} + B\text{-Trigger Level Error} + 0.5 \text{ ns.}^a$</p> <p>If the A and B Sweeps are triggered from different channels, add 0.5 ns for channel-to-channel mismatch.</p> <p>When the A Sweep is triggered by the Word Recognizer in synchronous mode, add 100 ns for probe delay; in asynchronous mode, add 200 ns for probe delay.</p>
<p>Minimum Measurable Delay Time</p>	<p>$\leq 70 \text{ ns.}^a$</p>
<p>Display Update Rate</p>	<p>In Auto Resolution, twice per second or once for every sweep, whichever is slower.^a</p> <p>In 1 ns, 100 ps, and 10 ps resolution modes, the update rate depends on the A SEC/DIV setting and the trigger repetition rate.</p>

^aPerformance requirement not checked in manual.

^bSee Tables 1-3 and 1-4.

^cB Time/Div includes SEC/DIV, X10 MAG, and VAR.

Table 1-2 (cont)

Characteristics	Performance Requirements
-----------------	--------------------------

DEFINITIONS

A Trigger Level Error = (A Trigger Level Readout Error)/SR_A.

B Trigger Level Error = (B Trigger Level Readout Error)/SR_B.

t_{REF} = rise time, reference trigger signal.

t_{DELT} = rise time, delta trigger signal.

SR_A = slew rate at trigger point, A Sweep trigger signal in div/sec.

SR_B = slew rate at trigger point, B Sweep trigger signal in div/sec.

SR_{REF} = slew rate at trigger point, reference trigger signal in div/sec.

SR_{DELT} = slew rate at trigger point, delta trigger signal in div/sec.

TJE = trigger jitter error.

For delay or delta time, disregarding noise in the signal, this term contributes <1 LSD if the slew rate is greater than 0.03 vertical div/ns or if the slew rate is greater than 30000 vertical div/horizontal div.

$$\text{Trigger Jitter} = [(\text{Reference Trigger Signal Jitter})^2 + (\text{Delta Trigger Signal Jitter})^2 + (\text{A Sweep Trigger Signal Jitter})^2]^{1/2}.$$

$$\begin{aligned} \text{Reference Trigger Signal Jitter} &= (e_{nS} + e_{nREF})/SR_{REF} \\ &= 0 \text{ for Frequency mode.} \end{aligned}$$

- e_{nS} = scope noise in div.
 - = 0.05 div for HF REJ trigger coupling.
 - = 0.1 div for DC trigger coupling, 5 mV to 5 V sensitivity.
 - = 0.15 div for DC trigger coupling, 2 mV sensitivity.

e_{nREF} = reference signal rms noise in div.

$$\begin{aligned} \text{Delta Trigger Signal Jitter} &= (e_{nS} + e_{nDELT})/SR_{DELT} \\ &= 0 \text{ for Frequency or Delay mode.} \end{aligned}$$

e_{nDELT} = delta signal rms noise in div.

$$\text{A Trigger Signal Sweep Jitter} = (e_{nS} + e_{nA})/SR_A.$$

e_{nA} = A sweep trigger signal rms noise in div.

When the Word Recognizer supplies a trigger in synchronous mode, the trigger jitter of the associated trigger signal is <1 ns; in asynchronous mode, the associated trigger signal jitter is <20 ns.

N = number of averages during measurement interval.

= see Table 1-3 for Delay or Delta Time.

= (measured frequency) × (measurement interval) for Frequency or Period.

Measurement Interval = 0.5 s or two periods of measured signal, whichever is greater.

Table 1-2 (cont)

Characteristics	Performance Requirements
ADDED DELTA-DELAY-TIME CHARACTERISTICS WITH C/T/T	
Run After Delay Accuracy	$\text{LSD}^b + [0.0008 \times (\text{A SEC/DIV})] + [0.01 \times (\text{B Time/Div})^c] + 83 \text{ ps.}^a$ <p>When the A Sweep is triggered by the Word Recognizer in synchronous mode, add 1 ns for probe jitter; in asynchronous mode, add 20 ns for probe jitter.</p>
Triggerable After Delay Accuracy Superimposed Delta Time	<p>Both delays are within 70 ns to 10 times the A-SEC/DIV setting.</p> $\text{LSD}^b + [0.01 \times (\text{B Time/Div})^c] + [10 \text{ ppm} \times (\text{A SEC/DIV})] + [10 \text{ ppm} \times (\text{measured interval})] + 50 \text{ ps} + \text{TJE.}^a$ <p>If CH 3 or CH 4 is one channel of a two-channel measurement, add 0.5 ns for channel-to-channel delay mismatch.</p>
Nonsuperimposed Delta Time	$\text{LSD}^b + t_{\text{REF}} - t_{\text{DELT}} ^d + \text{TJE} + [(0.0005 \text{ div}) \times (1/\text{SR}_{\text{REF}} + 1/\text{SR}_{\text{DELT}})] + [10 \text{ ppm} \times (\text{A SEC/DIV})] + [10 \text{ ppm} \times (\text{measured interval})] + 50 \text{ ps.}$ <p>If A and B sweeps are triggered from different channels, add 0.5 ns for channel-to-channel mismatch + $[0.5 \text{ div} \times (1/\text{SR}_{\text{REF}} + 1/\text{SR}_{\text{DELT}})]$ for trigger offset.</p>
Display Update Rate	<p>In Auto Resolution, twice per second or once for every four sweeps, whichever is slower.^a</p> <p>In 1 ns, 100 ps, and 10 ps resolution modes, the update rate depends on the A SEC/DIV setting and the trigger repetition rate.</p>

^aPerformance requirement not checked in manual.

^bSee Tables 1-3 and 1-4.

^cB Time/Div includes SEC/DIV, X10 MAG, and VAR.

^dThis term assumes the trigger points are between the 10% and 90% points of the waveforms. Fall time is expressed as a negative risetime.



**Table 1-3
Resolution Selections**

A SEC/DIV	Selection	Least Digit	N for Average
10 ns to 500 ms	AUTO	See Table 1-4	See Table 1-4
10 ns to 5 μ s	10 ps	10 ps	> 10 ⁶
	100 ps	100 ps	> 10 ⁴
	1 ns	1 ns	> 100
10 μ s to 50 μ s	10 ps or 100 ps	100 ps	> 10 ⁴
	1 ns	1 ns	> 100
100 μ s to 500 μ s	10 ps to 1 ns	1 ns	> 100
1 ms to 5 ms	Any	10 ns	> 1
10 ms to 50 ms	Any	100 ns	> 1
100 ms to 500 ms	Any	1 μ s	> 1

**Table 1-4
Resolution Selections**

A SEC/DIV	Trigger Rate	Least Digit	N for Average
10 ns to 2 μ s	> 20 kHz	100 ps	> 10 ⁴
10 ns to 2 μ s	200 Hz to 20 kHz	1 ns	> 100
5 μ s to 200 μ s	> 200 Hz	1 ns	> 100
10 ns to 200 μ s	< 200 Hz	10 ns	> 1
500 μ s to 5 ms	Any	10 ns	> 1
10 ms to 50 ms	Any	100 ns	> 1
100 ms to 500 ms	Any	1 μ s	> 1

Table 1-5
Option 09 (WR) Electrical Characteristics

Characteristics	Performance Requirements
SYNCHRONOUS MODE	
Data Setup Time D ₀ —D ₁₅ and Q	25 ns.
Data Hold Time D ₀ —D ₁₅ and Q	0 ns.
Minimum Clock Pulse Width	
High	20 ns.
Low	20 ns.
Minimum Clock Period	50 ns. ^a
Delay from Selected Clock Edge to Word Out from C/T/T	≤55 ns.
ASYNCHRONOUS MODE	
Maximum Trigger Frequency	10 MHz. ^a
Minimum Coincidence Between Data Inputs (D ₀ —D ₁₅ and Q) Resulting in a Trigger	<85 ns.
Maximum Coincidence Between Data Inputs (D ₀ —D ₁₅ and Q) Without Producing a Trigger	>20 ns.
Delay from Input Word Coincidence to Word Out	≤140 ns.
INPUTS AND OUTPUTS	
Input Voltages	
Minimum Input Voltage 	-0.5 V. ^a
Maximum Input Voltage 	5.5 V. ^a
Maximum Input Low Voltage	0.6 V. ^a
Minimum Input High Voltage	2.0 V. ^a
WORD RECOG OUT	
High	> 2.5 V LSTTL output. ^a
Low	< 0.5 V LSTTL output. ^a
Input High Current	≤20 μA. ^a
Input Low Current	≥ -0.6 mA source. ^a

^aPerformance requirement not checked in manual.

**Table 1-6
Mechanical Characteristics**

Characteristics	Performance Requirements
Weight	
With Accessories and Pouch	10.2 kg (22.4 lb).
With Option 06 and 09	12.0 kg (26.44 lb).
Without Accessories and Pouch	9.3 kg (20.5 lb).
Domestic Shipping Weight	12.8 kg (28.2 lb).
With Option 06 and 09	17.6 kg (38.8 lb).
Height	
Without Accessories Pouch, with or without Options 06 and 09	160 mm (6.29 in).
With Feet and Accessories Pouch, with or without Options 06 and 09	243 mm ± 25.4 mm (9.56 in ± 1.0 in).
Width (with handle)	338 mm (13.31 in).
Depth	
With Front Panel Cover	434 mm (17.1 in).
With Handle Extended	508 mm (20.0 in).
Cooling	Forced-air circulation.
Finish	Tek Blue vinyl clad material on aluminum cabinet.
Construction	Aluminum-alloy chassis (sheet metal). Plastic-laminate front panel. Glass-laminate circuit boards.

**Table 1-7
Environmental Requirements**

Characteristics	Performance Requirements
	<p>Environmental requirements qualify the electrical and mechanical specifications. When not rack mounted, the instruments meet the environmental requirements of MIL-T-28800C for Type III, Class 3, Style C equipment, with the humidity and temperature requirements defined in paragraphs 3.9.2.2, 3.9.2.3, and 3.9.2.4. Rack mounting changes the temperature, vibration, and shock capabilities. The rack mounted instruments meet or exceed the requirements of MIL-T-28800C with respect to Type III, Class 5, Style C equipment with the rack-mounting rear-support kit installed. Rack mounted instruments will be capable of meeting or exceeding the requirements of Tektronix Standard 062-2853-00, class 5.</p>
<p>Temperature Operating</p>	<p>-15°C to +55°C.</p> <p>For a rack mounted instrument, ambient temperature should be measured at the instrument's air inlet. Fan exhaust temperature should not exceed +65°C.</p>
<p>Nonoperating (Storage)</p>	<p>-62°C to +85°C.</p>
<p>Altitude Operating</p>	<p>To 15,000 feet. Maximum operating temperature decreases 1°C for each 1000 feet above 5000 feet.</p>
<p>Nonoperating (Storage)</p>	<p>To 50,000 feet.</p>
<p>Humidity Operating and Storage</p>	<p>Stored at 95% relative humidity for five cycles (120 hours) from 30°C to 60°C, with operational performance checks at 30°C and 55°C.</p>
<p>Vibration (operating) Not Rack Mounted</p>	<p>15 minutes along each of three axes at a total displacement of 0.025 inch p-p (4 g at 55 Hz), with frequency varied from 10 Hz to 55 Hz in one minute sweeps. Hold 10 minutes at each major resonance or, if none exists, hold 10 minutes at 55 Hz (75 minutes total test time).</p>
<p>Rack Mounted</p>	<p>Change displacement to 0.015 inch p-p (2.3 g at 55 Hz).</p>
<p>Shock (operating and nonoperating) Not Rack Mounted</p>	<p>50 g, half sine, 11 ms duration, three shocks on each face, for a total of 18 shocks.</p>
<p>Rack Mounted</p>	<p>30 g.</p>
<p>Transit Drop (not in shipping package)</p>	<p>8-inch drop on each corner and each face (MIL-T-28800C, para. 4.5.5.4.3).</p>

Table 1-7 (cont)

Characteristics	Performance Requirements
Bench Handling (cabinet on and cabinet off)	MIL-STD-810C, Method 516.2, Procedure V (MIL-T-28800C, para. 4.5.5.4.3).
Topple (operating with cabinet installed)	Set on rear feet and allow to topple over onto each of four adjacent faces (Tektronix Standard 062-2858-00).
Packaged Transportation Drop	Meets the limits of the National Safe Transit Assn., test procedure 1A-B-2; 10 drops of 36 inches (Tektronix Standard 062-2858-00).
Packaged Transportation (Vibration)	Meets the limits of the National Safe Transit Assn., test procedure 1A-B-1; excursion of 1 inch p-p at 4.63 Hz (1.1 g) for 30 minutes (Tektronix Standard 062-2858-00).
EMI (Electro-magnetic Interference)	Meets MIL-T-28800C; MIL-STD-461B, part 4 (CE-03 and CS-02), part 5 (CS-06 and RS-02), and part 7 (CS-01, RE-02, and RS-03)—limited to 1 GHz; VDE 0871, Category B; Part 15 of FCC Rules and Regulations, Subpart J, Class A; and Tektronix Standard 062-2866-00.
Electrostatic Discharge Susceptibility	Meets Tektronix Standard 062-2862-00. The instrument will not change control states with discharges of less than 10 kV.
X-Ray Radiation	Meets requirements of Tektronix Standard 062-1860-00.

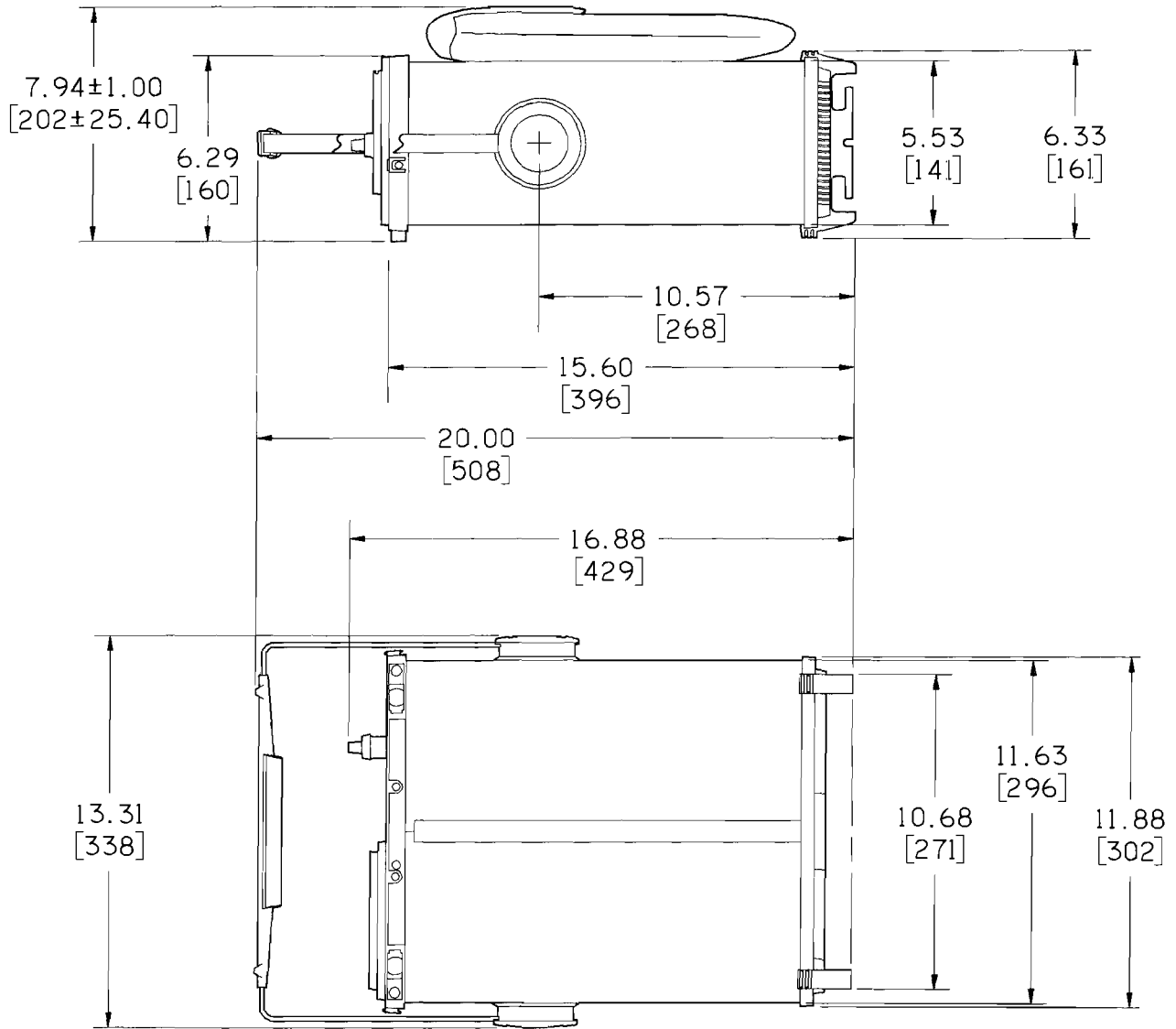

Dimensions are in inches [mm]

6019-01

Figure 1-1. Dimensional drawing.

OPERATING INFORMATION

SAFETY

Before connecting the oscilloscope to a power source, read entirely both this section and the Safety Summary at the front of this manual. Be sure you have the training required to safely connect the instrument inputs to the signals you will be measuring. Refer to the Safety Summary for power source, grounding, and other safety considerations pertaining to the use of the instrument.



This instrument may be damaged if operated with the LINE VOLTAGE SELECTOR switch set for the wrong applied ac input-source voltage or if the wrong line fuse is installed.

LINE VOLTAGE SELECTOR

The oscilloscope operates from either a 115-V or a 230-V nominal ac power-line with any frequency from 48 Hz to 440 Hz. Before connecting the power cord to a power source, verify that the LINE VOLTAGE SELECTOR switch, located on the rear panel (see Figure 2-1), is set correctly (see Table 2-1) and that the line fuse is correct. To convert the instrument for operation on the other line-voltage range, move the LINE VOLTAGE SELECTOR switch to the correct nominal ac source-voltage setting. The detachable power cord may have to be replaced to match the particular power source.

LINE FUSE

To verify the instrument power-input fuse rating, do the following steps:

1. Press in the fuse-holder cap and release it with a slight counterclockwise rotation. Pull the cap (with the attached fuse inside) out of the fuse holder.

2. Verify that the fuse is of the type listed on the back of the instrument. Then install the proper fuse and reinstall the proper fuse-holder cap. The two types of fuses listed are not directly interchangeable; they require different types of fuse caps. Included in the accessory pouch is a 5x20 mm fuse holder cap for use with 1.6 A, 250 V, 5x20 mm (IEC 127) fuses.

POWER CORD

This instrument has a detachable, three-wire power cord with a three-contact plug for connection to both the power source and protective ground. The power cord is secured to the rear panel by a cord-set-securing clamp. The protective-ground contact on the plug connects through the power-cord to the external metal parts of the instrument. For electrical-shock protection, insert this plug into a power-source outlet that has a properly grounded protective-ground contact.

Instruments are shipped with the required power cord as ordered by the customer. Available power-cord information is presented in Table 2-1, and part numbers are listed in "Options and Accessories" (Section 7). Contact your Tektronix representative or local Tektronix Field Office for additional power-cord information.

INSTRUMENT COOLING

To prevent instrument damage from internally generated heat, adequate air flow must be maintained. Before turning on the power, verify that the spaces around the air-intake holes on the bottom of the cabinet and the fan-exhaust holes in the rear panel are free of any obstruction to airflow.

OPERATING INFORMATION

All operating information pertaining to the use of these instruments is found in the respective instrument Operators Manual.

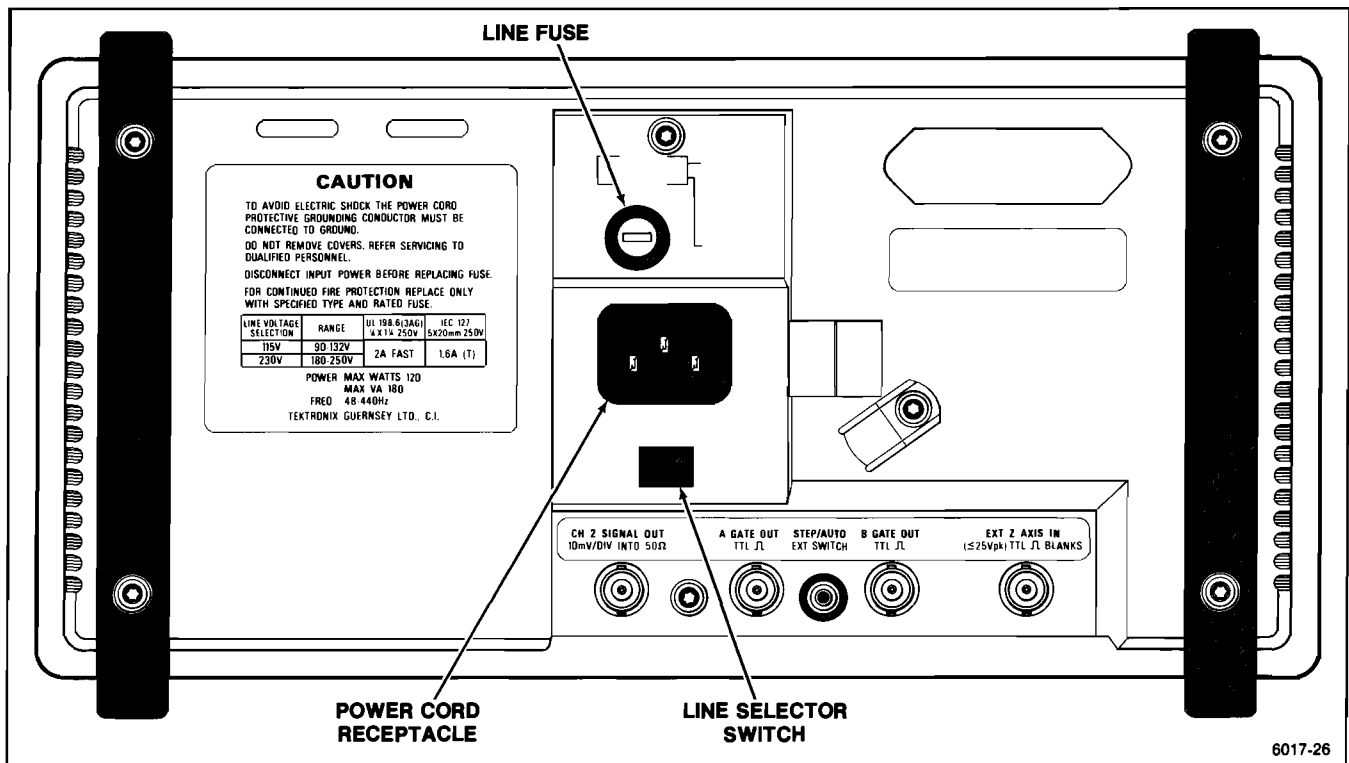

Figure 2-1. Line selector switch, line fuse, and detachable power cord.

START-UP

The oscilloscope automatically performs a set of diagnostic tests each time it is turned on. These tests warn the user of any available indication that the instrument may not be fully functional. The tests run for several seconds after power is applied. If no faults are encountered, the instrument operates normally. A failure of any of the power-up tests will be indicated by either a flashing TRIG'D indicator on the instrument front panel or a bottom-line readout on the CRT in the form: **TEST XX FAIL YY** (where XX is the test number and YY is the failure code of the failed test).

If a failure of any power-up test occurs, the instrument may still be usable for some applications. To operate the instrument after a power-up test failure, press the A/B TRIG button (or A/B MENU). Even if the instrument then functions for your particular measurement requirement, it should be repaired by a qualified service technician at the earliest convenience. Additional information on the power-up tests and troubleshooting may be found in the "Maintenance" section of this manual. Consult your service department, your local Tektronix Service Center, or nearest Tektronix representative if additional assistance is needed.

REPACKAGING FOR SHIPMENT

If this instrument is to be shipped by commercial transportation, it should be packaged in the original manner. The carton and packaging material in which your instrument was shipped to you should be retained for this purpose.

If the original packaging is unfit for use or is not available, repackage the instrument as follows:

1. Obtain a corrugated cardboard shipping carton having inside dimensions at least six inches greater than the instrument dimensions and having a carton test strength of at least 275 pounds.
2. If the instrument is to be shipped to a Tektronix Service Center for service or repair, attach a tag to the instrument showing the following: owner of the instrument (with address), the name of a person at your firm who can be contacted, complete instrument type and serial number, and a description of the service required.

3. Wrap the instrument with polyethylene sheeting or equivalent to protect the outside finish and prevent entry of packing materials into the instrument.
4. Cushion the instrument on all sides by tightly packing dunnage or urethane foam between the carton and the instrument, allowing three inches on each side.
5. Seal the carton with shipping tape or with an industrial stapler.
6. Mark the address of the Tektronix Service Center and your return address on the carton in one or more prominent locations.

**Table 2-1
Power Cord and Voltage Data**

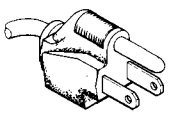
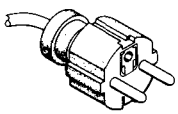
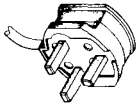
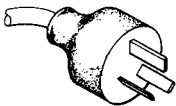
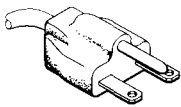
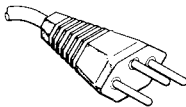
Plug Configuration	Option	Power Cord/ Plug Type	Line Voltage Selector	Reference Standards ^b
	U.S. Std.	U.S. 120V	115V	ANSI C73.11 NEMA 5-15-P IEC 83 UL 198.6
	A1	EURO 220V	230V	CEE(7), II, IV, VII IEC 83 IEC 127
	A2	UK ^a 240V	230V	BS 1363 IEC 83 IEC 127
	A3	Australian 240V	230V	AS C112 IEC 127
	A4	North American 240V	230V	ANSI C73.20 NEMA 6-15-P IEC 83 UL 198.6
	A5	Switzerland 220V	230V	SEV IEC 127

^aA 6A, type C fuse is also installed inside the plug of the Option A2 power cord.

^bReference Standards Abbreviations:

ANSI—American National Standards Institute

AS—Standards Association of Australia

BS—British Standards Institution

CEE—International Commission on Rules for the Approval of Electrical Equipment

IEC—International Electrotechnical Commission

NEMA—National Electrical Manufacturer's Association

SEV—Schweizerischer Elektrotechnischer Verein

UL—Underwriters Laboratories Inc.

THEORY OF OPERATION

INTRODUCTION

SECTION ORGANIZATION

This section contains a functional description of the instrument circuitry. The discussion begins with an overview of the instrument functions and continues with detailed explanations of each major circuit. Reference is made to supporting schematic and block diagrams which will facilitate understanding of the text. These diagrams show interconnections between parts of the circuitry, identify circuit components, list specific component values, and indicate interrelationships with front-panel controls.

The detailed block diagram and the schematic diagrams are located in the tabbed "Diagrams" section at the rear of this manual, while smaller functional diagrams are contained within this section near their respective text. The particular schematic diagram associated with each circuit description is identified in the text, and the diagram number is shown (enclosed within a diamond symbol) on the tab of the appropriate foldout page. For optimum understanding of the circuit being described, refer to both the applicable schematic diagram and the functional block diagram.

HYBRID AND INTEGRATED CIRCUIT DESCRIPTIONS

Digital Logic Conventions

Digital logic circuits perform many functions within this instrument. The operation of these circuits is represented by specific logic symbology and terminology. Most logic-function descriptions contained in this manual use the positive-logic convention. Positive logic is a system of notation whereby the more positive of two levels is the TRUE (or 1) state; the more negative level is the FALSE (or 0) state. In the logic descriptions, the TRUE state is referred to as HI, and the FALSE state is referred to as LO. The specific voltages which constitute a HI or a LO state vary between individual devices. For specific device characteristics, refer to the manufacturer's data book.

Hybrids

Some of the circuits in this instrument are implemented in hybrid devices. The hybrids are specialized electronic devices combining thick-film and semiconductor technologies. Passive, thick-film components and active, semiconductor components are interconnected to form the circuit on a ceramic carrier. The end result is a relatively small "building block" with enhanced performance characteristics, all in one package. Hybrid circuits are shown on schematics simply as blocks with inputs and outputs. Information about hybrid functioning is contained in the related portion of the Detailed Circuit Description.

Linear Devices

The operation of individual linear integrated circuit devices is described in this section using waveforms or other graphic techniques to illustrate their operation.

BLOCK DIAGRAM

The following discussion is provided to aid in understanding the overall operation of the instrument circuitry before the individual circuits are discussed in detail. A simplified block diagram of the instrument, showing basic interconnections, is shown in Figure 3-1. The diamond-enclosed numbers in each block refer to the schematic diagram(s) at the rear of this manual in which the related circuitry is located.

BLOCK DESCRIPTION

The Low Voltage Power Supply is a high-efficiency, switching supply with active output regulation that transforms the ac source voltage to the various dc voltages required by the instrument. The High Voltage Power Supply circuit develops the high accelerating potentials required by the crt, using voltage multiplication techniques, and the DC Restorer provides interfacing for the low-potential intensity signals from the Z-Axis Amplifier to the crt control grid.

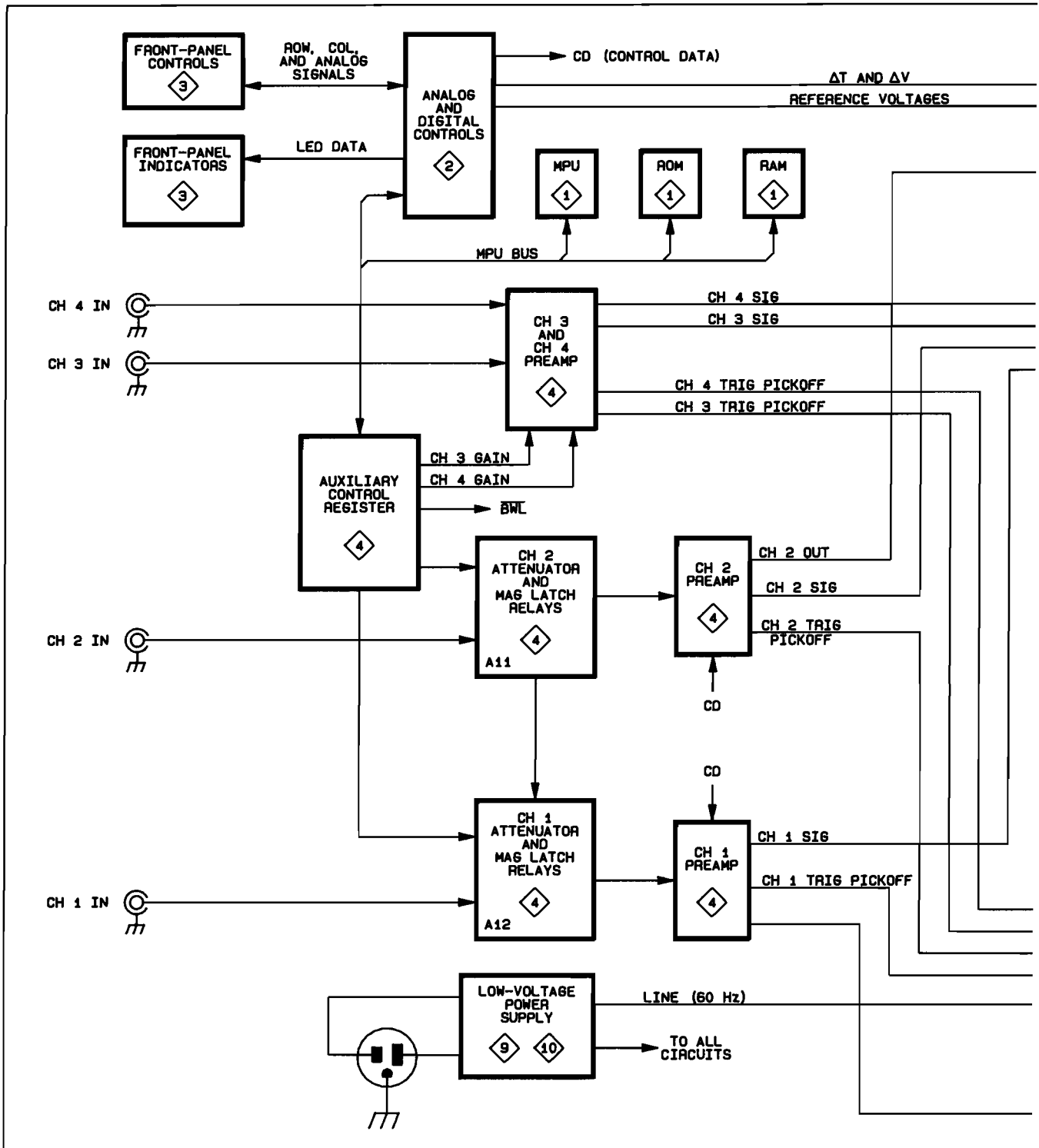

Figure 3-1. Instrument block diagram.

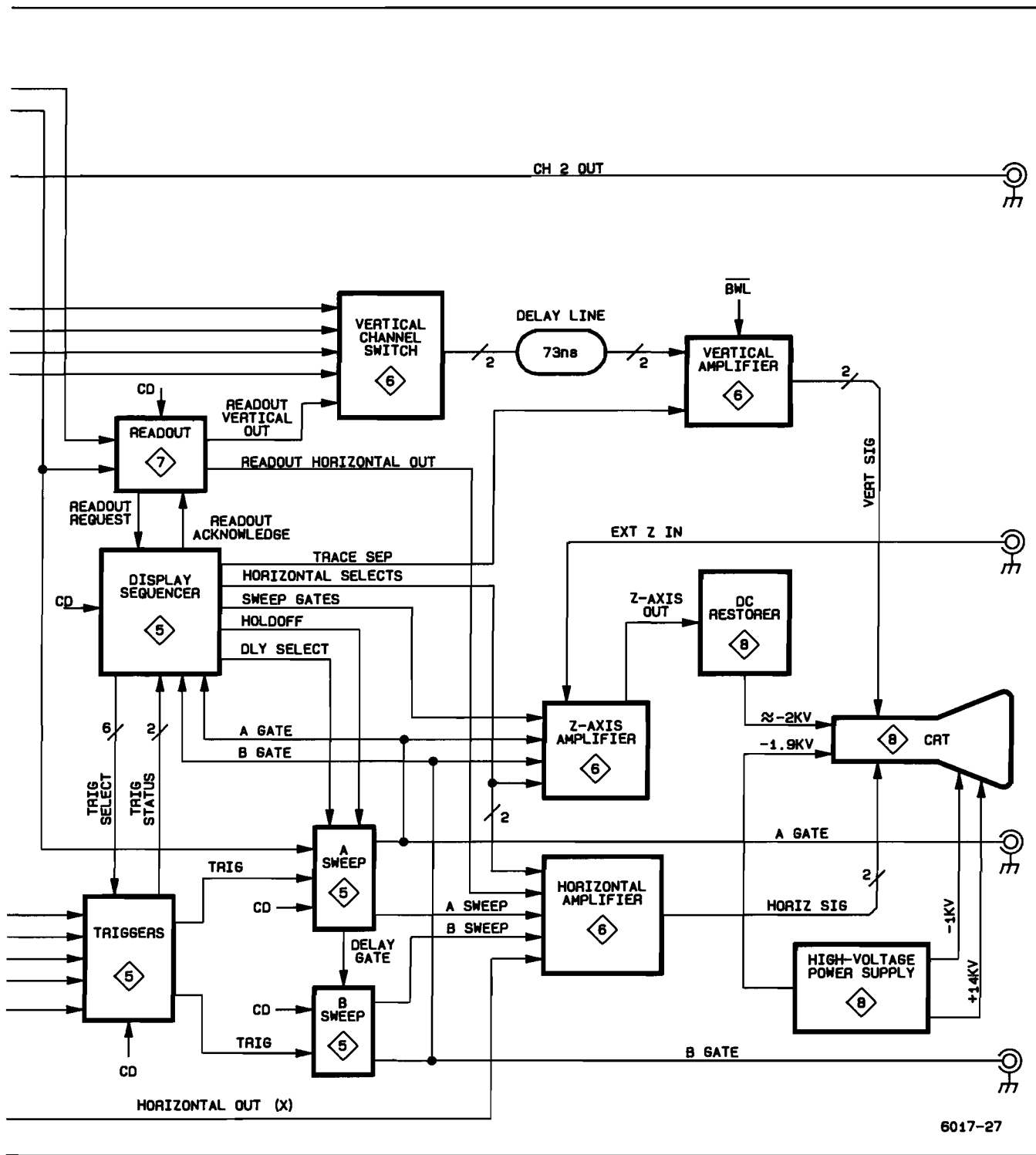

Figure 3-1. Instrument block diagram (cont).

Theory of Operation—2445A/2455A Service

Most of the activities of the instrument are directed by a microprocessor. The microprocessor, under firmware control (firmware is the programmed instructions contained in read-only memory that tells the processor how to operate), monitors instrument functions and sets up the operating modes according to the instructions received.

Various types of data read to and from the Microprocessor (program instructions, constants, control data, etc.) are all transferred over a group of eight bidirectional signal lines called the Data Bus. The Data Bus is dedicated solely to microprocessor-related data transfer.

Another group of signal lines, called the Address Bus, are responsible for selecting or "addressing" the memory location or device that the Microprocessor wants to communicate with. Typically, depending on the instruction being executed, the processor places an address on the Address Bus to identify the location the Microprocessor must communicate with. This address, along with some enabling logic, opens up an appropriate data path between the processor and the device or memory location via the Data Bus; and data is either read from or written to that location by the processor.

While executing the control program, the Microprocessor retrieves previously stored calibration constants and front-panel settings and, as necessary places program-generated data in temporary storage for later use. The battery backed up RAM provides these storage functions.

When power is applied to the instrument, a brief initialization sequence is performed, and then the processor begins scanning the front-panel controls. The switch settings detected and the retrieved front-panel data from the battery backed up RAM causes the processor to set various control registers and control voltages within the instrument that define the operating mode of the instrument. These register settings and voltage levels control the vertical channel selection and deflection factors, the sweep rate, the triggering parameters, the readout activity, and sequencing of the display. Loading the control data into the various registers throughout the instrument is done using a common serial data line (CD). Individual control clock signals (CC) determine which register is loaded from the common data line.

Coordination of the vertical, horizontal, and Z-Axis (intensity) components of the display must be done in real time. Due to the speed of these display changes and the precise timing relationships that must be maintained between display events, direct sequencing of the display is beyond the capabilities of the processor control. Instead, control data from the processor is sent to the Display

Sequencer (a specialized integrated circuit) which responds by setting up the various signals that control the stages handling real-time display signals. The controlled stages are stepped through a predefined sequence that is determined by the control data. Typically, as the sequence is being executed, the Display Sequencer will be changing vertical signal sources, Z-Axis intensity levels, triggering sources, and horizontal sweep signal sources. The specific activities being carried out by the Display Sequencer depend on the display mode called for by the control data.

Vertical deflection for crt displays comes from one or more of the four front-panel vertical inputs and, when displaying readout information, from the Readout circuitry. Signals applied to the front-panel Channel 1 and Channel 2 inputs are connected to their respective Preamplifiers via processor-controlled Attenuator networks. Control data from the Microprocessor defining the attenuation factor for each channel is serially loaded into the Auxiliary Control Register and then strobed into the Attenuator Mag-Latch Relays in parallel. The relay switches of each Attenuator network are either opened or closed, depending on the data supplied to the Mag-Latch Relay Drivers. The relays are magnetically latched and remain as set until new control data is strobed in. The Auxiliary Control Register is therefore available, and different mode data is clocked into the register to set up other portions of the instrument.

Attenuated Channel 1 and Channel 2 input signals are amplified by their respective Preamplifiers. The gain factor for the Channel 1 and Channel 2 Preamplifiers is settable by control data from the processor. The Channel 3 and Channel 4 input signals are amplified by their respective Preamplifiers by either of two gain factors set by control bits from the Auxiliary Control Register. All four of these preamplified signals are applied to the Vertical Channel Switch where they are selected by the Display Sequencer for display when required.

Each of the vertical signals is also applied to the A and B Trigger circuitry via trigger pickoff outputs from the Preamplifier stages. Any one of the signals may be selected as the trigger SOURCE for either the A or the B Trigger circuitry as directed by the Display Sequencer. The line trigger signal provides an added trigger source for A Sweeps only. Control data from the Microprocessor is written to the Trigger circuitry to define the triggering LEVEL, SLOPE, and COUPLING criteria. When the selected trigger signal meets these requirements, a sweep can be initiated. The Trigger circuit initiates both the A Sweep and the B Sweep as required by the display mode selected.

In the case of A Sweeps, the LO state of the THO (trigger holdoff) signal from the Display Sequencer enables

the A Sweep circuit and the next A trigger initiates the sweep. For B sweeps, and in the case of intensified sweeps, the A Sweep delay gate signal (DG) enables the B Sweep circuit. Depending on the B trigger mode selected, a B Sweep will be initiated either immediately (RUN AFT DLY) or on the next B trigger signal (TRIG AFT DLY). The slope of the sweep ramp is dependent on Microprocessor-generated control data loaded into the internal control register of the A and B Sweep circuit hybrids.

Sweep signals generated by each of the Sweep hybrids are applied to the Horizontal Amplifier. The Horizontal Amplifier is directed by the Display Sequencer to select one of the sweep ramps for amplification in sequence. In the case of Readout and X-Y displays, the X-Readout and CH 1 input signals are selected to be amplified, also under direction of the Display Sequencer.

To control the display intensity, the Display Sequencer directs the Z-Axis circuit to unblank the display at the appropriate time for the sweeps and readout displays.

When the display is unblanked, the Display Sequencer selects the display intensity for either waveform displays or for readout displays by switching control of the Z-Axis beam current between the front-panel INTENSITY and READOUT INTENSITY potentiometers as appropriate.

During readout displays, the vertical dot-position signal from the Readout circuitry is applied to the Vertical Amplifier via the Vertical Channel Switch. Horizontal dot-position deflection for the readout display is selected by internal switching in the Horizontal Amplifier.

The vertical, horizontal, and Z-Axis signals are applied to their respective amplifiers where they are raised to crt-drive levels. The output signals from the Vertical and Horizontal Amplifiers are applied directly to the crt deflection plates. The Z-Axis Amplifier output signal requires interfacing to the high-potential crt environment before application to the crt control grid. The necessary Z-Axis interfacing is provided by the DC Restorer circuit located on the High-Voltage circuit board. The resulting display may be of waveforms, alphanumeric readout, or a combination of both.

DETAILED CIRCUIT DESCRIPTION

INTRODUCTION

The following discussion provides detailed information concerning the electrical operation and circuit relationships of the instrument. Circuitry unique to the instrument is described in detail, while circuits common in the electronics industry are not. The descriptions are accompanied by supporting illustrations and tables. Diagrams identified in the text, on which associated circuitry is shown, are located at the rear of this manual in the tabbed foldout pages.

PROCESSOR AND DIGITAL CONTROL

The Processor and Digital Control circuitry (diagram 1) directs the operation of most oscilloscope functions by following firmware control instructions stored in memory. These instructions direct the Microprocessor to monitor the front-panel controls and to send control signals that set up the various signal processing circuits accordingly.

Microprocessor

The Microprocessor (U2140) is the center of control activities. It has an eight-bit, bidirectional data bus for data

display transfer (D0 through D7) and a 16-bit address bus (A0 through A15) for selecting the source or destination of the data. Precise timing of instruction execution, addressing, and data transfer is provided by an external, crystal-controlled clock signal.

The clock signal is developed by the Microprocessor Clock stage and applied to the Microprocessor at pin 39. Using the external clock as an reference, the Microprocessor generates synchronized control output signals, R/\bar{W} (read-write), E (enable), and VMA (valid memory address)] that maintain proper timing relationships throughout the instrument.

Microprocessor Clock

The Microprocessor Clock stage generates a 5-MHz square-wave clock signal to the Microprocessor and a 10-MHz clock signal to portions of the Readout circuitry. Inverter U2540A acts as an oscillator with crystal Y2540 providing feedback at the resonant frequency. The required phase shift for oscillation to occur is produced by C2550, C2551, R2545, and the crystal. The RC network composed of R2543, C2640, R2541, and R2542 biases input pin 1 of U2540A in the active region and establishes approximate symmetry of the oscillator output. The signal is buffered and inverted by U2540B to provide the 10-MHz clock signal.

Theory of Operation—2445A/2455A Service

Flip-flop U2440A is a divide-by-two circuit that reduces the 10-MHz clock down to a 5-MHz square-wave signal used to clock the Microprocessor and the Display Sequencer. The 10-MHz clock is supplied to the Readout Board for dot timing and is also available for use with option circuitry.

Reset Control

The Reset Control circuitry ensures that, at power up, the Microprocessor begins program execution from a known point in memory and with all the processor registers in known states. It also allows the processor to reset itself when power is turned off so that the instrument powers down in a known state.

POWER UP SEQUENCE. Reset generator U2240 generates the power-up reset. As power is applied to the instrument U2240 tests the voltage at U2240 pin 7. The reset generator forces U2240 pin 5 LO, and the LO is applied to the processor RESET input (pin 40). After the SENSE input reaches its nominal voltage level, the reset condition continues to allow the microprocessor system time to reset. The reset continues for the time determined by C2350. The effect of power supply transients is reduced by C2240. After the supplies reach their nominal level and the delay period ends U2240 pin 5 goes HI. The RESET signal to the processor then goes HI to enable normal execution to begin, and the processor is directed to the starting address of the power-up routine, which it then performs.

POWER DOWN SEQUENCE. When the instrument power switch is turned off, the PWR UP signal from J251 pin 12 immediately goes LO. This LO generates the NMI (non-maskable interrupt) request to the processor on pin 6 which causes the processor to branch to the power-down routine. Under direction of that routine, the processor begins shutting down the instrument in an orderly fashion before the power supply outputs can drop below the operating thresholds. This routine disconnects the CH1 and CH2 50- Ω input terminations to protect them from accidental application of excessive voltage during storage or bench handling.

As the operating voltages are falling, the Reset circuitry must not generate a false RESET signal to the processor. Such a restart when the power supply voltages are outside their normal operating range would produce unpredictable processor operation that could alter the contents of the battery backed up RAM. When the processor has completed all the other power-down tasks, it finally sets the PWR DOWN signal HI via U2310 (diagram 2).

This signal is applied to inverter U2650C at pin 11. Pin 9 of U2650C goes LO and immediately pulls pin 2 of Reset Generator U2240 LO to prevent a reset to the processor. Reset Generator U2240 immediately switches state to assert the RESET signal to the processor. The RESET signal is held LO until the power supplies have fully discharged.

For diagnostic purposes, the PWR DOWN reset signal can be disabled. Moving jumper P503 to the DIAG (diagnostic) position keeps U2240 pin 2 HI. The RESET signal is therefore held HI, and the processor can execute a free-running NOP (no operation) loop without interruption if the PWR DOWN bit is set HI while the Address Bus is incrementing.

Data Bus

Tri-state buffer U2350 is used to buffer the data signals to the Microprocessor from other devices on the bus. When not enabled, the device is switched to isolate the processor from the buffered Data Bus. Buffer U2350 is enabled via the Read-Write Latch U2440B when the processor reads data from another device on the bus.

When the processor writes data onto the bus, Octal Latch U2450 is enabled by the Read-Write Latch U2440B. When the E (enable) signal at pin 11 of U2450 is HI, processor data bits are passed asynchronously through the latch to the buffered data bus. When the E signal goes LO, data bits meeting setup times are latched into the device. The latched Q outputs provide the required drive current to the various devices on the bus and ensure that data hold times are met for correct data transfer. When the Read-Write Latch places a HI on pin 1 of U2450, latch U2450 is disabled, and the outputs are switched to their high-impedance state.

Data transfers to and from the processor may be interrupted by removing Diag/Norm Jumper P503. This forces a NOP (no operation) condition that is useful for verifying the functionality of the processor (when a data-bus device is suspected of causing a system failure) or for troubleshooting the Address Bus and Address Decode circuitry. Removing the jumper removes the operating power from both U2350 and U2450 to disconnect the Microprocessor from the buffered Data Bus. With the Data Bus disconnected, a resistor network pulls the processor Data Bus lines (D0 through D7) to a NOP (no operation) instruction. A NOP causes the Microprocessor to continuously increment through its address field. The Address Decode circuitry may then be checked to determine if it is operating properly.

Address Decode

The Address Decode circuitry generates enabling signals and strobes that allow the Microprocessor to control the various devices and circuit functions. The controlling signals are generated as a result of the Microprocessor placing specific addresses on the Address Bus. Figure 3-2 illustrates the enables and strobes generated by the Address Decode circuitry.

logic device, a three-line-to-eight-line decoder, and a four-line-to-sixteen-line decoder attached to the Address Bus. The five most significant address bits are decoded by U2250. This device initially separates the total addressable-memory space (64K-bytes) into thirty-two, 2K-byte blocks. Addresses in the top 32K-bytes (address bit A15 HI) select one of two read-only memories (ROM), U2160, or U2260. When the VMA (Valid Memory Address) and E (Enable) outputs from the Microprocessor go HI, the selected ROM is enabled, and the data from the selected address location is read from the ROM.

Address decoding is performed by a programmable array

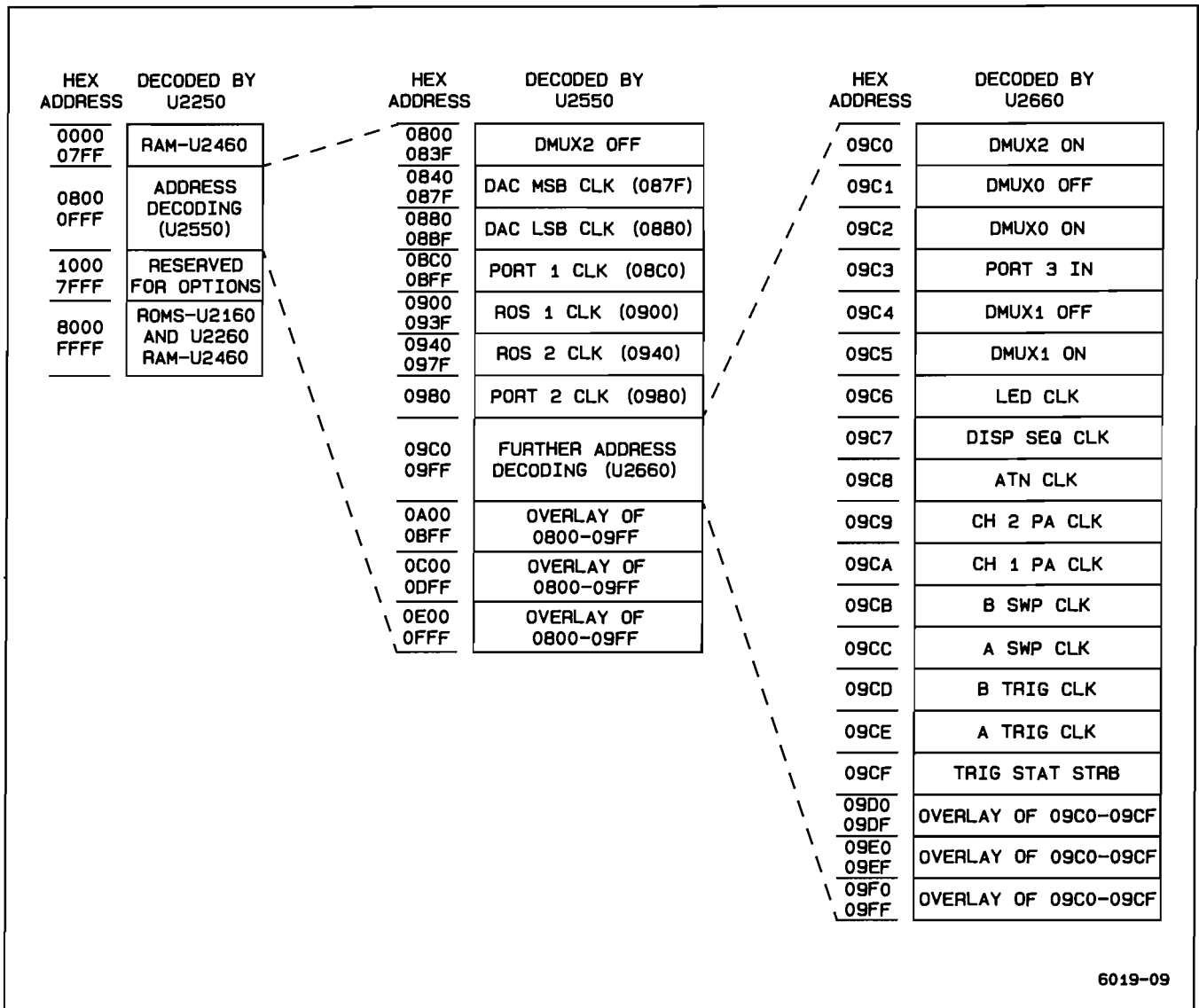

Figure 3-2. Address decoding.

Theory of Operation—2445A/2455A Service

The programmable array logic device also generates the \overline{OE} and \overline{WE} signals to the random-access memory (RAM). This RAM can be accessed with addresses 8000 to 9FFF if either ROM SELECT or PAGE SELECT signals are HI. In this mode the ROMs, U2160 and U2260 are not accessible in this address range.

Of the bottom 32K-bytes of addresses, only the lowest 4K-bytes are further decoded. Addresses in the lowest 2K-byte block of addresses will cause U2250 to generate an enable signal to the RAM, U2460. Addresses in the next 2K-byte block of addresses will enable U2550 to do the next stage of address decoding.

The level of decoding performed by U2550 uses address bits A6, A7, and A8 to separate the addresses within the 2K-byte block of addresses 0800 thru 0FFF into 32 groups of 64 addresses. Address bits A9 and A10 are not used in the decoding scheme, so each of these 32 blocks is not uniquely identified. This results in four duplicate sections within the address block, each consisting of eight groups of 64 addresses. The upper three sections in the address space are never used; therefore, decoding by U2550 may be more simply thought of as eight groups of 64 address locations. Addresses within these eight groups generate control signals to other portions of the instrument.

The final level of address decoding is done by four-line-to-sixteen-line decoder U2660. When enabled by the Y7 output of U2550, this decoder separates the highest 64-address group decoded by U2550 into 16 individual control signals. In this level of decoding, address bits A4 and A5 are not decoded, so that the 64 possible addresses consist of four overlaid blocks of 16 addresses each.

Each of the control signals generated by the Address Decode circuitry are present only as long as the specific address defining that signal is present on the Address Bus. However, one of the addressable control signals decoded by U2550 and five of the addressable control signals decoded by U2660 are used to either set or reset flip-flops U2650A, U2650B, and U2650D. The control signals are, in effect, latched and remain present to enable multiplexers U2521, U2530, (diagram 2) and U170 (diagram 4). When enabled, these multiplexers route analog control signals from DAC (digital-to-analog converter) U2101 (diagram 2) to the various analog control circuits.

Read-only Memory (ROM)

The Read-only Memory consists of two, 64K-byte ROMs that contain operating instructions (firmware) used to control processor (and thus oscilloscope) operation. Addresses from the Microprocessor that fall within the top

32K-bytes of addressable space cause one of the two read-only memory integrated circuits to be enabled. (See Address Decode description.) Instructions are read out of the enabled ROM (or PROM) IC from the address location present on its 16 address input pin (A0 through A14, Page Select). The eight-bit data byte from the addressed location is placed onto the Buffered Data Bus (BD0 through BD7) to be read by the Microprocessor.

Random-Access Memory (RAM)

The RAM consists of integrated circuit U2460 and provides the Microprocessor with 8K-bytes of battery backed up temporary storage space for data that is developed during the execution of a routine. The RAM is enabled whenever an address in the lowest 2K-byte of addresses is placed on the Address Bus or whenever an address of 8000 thru 9FFF is placed on the Address bus with either Page Select or Rom Select set HI. When writing into the RAM, the write-enable signal (WE) on pin 27 of U2460 is set LO along with the chip enable (CE1) signal on pin 20. At the same time, the output-enable (OE) on pin 22 is HI to disable the RAM output drivers. Data is then written to the location addressed by the Microprocessor. If data is to be read from the RAM, the WE signal is set HI to place the RAM in the read mode, and the OE signal is set LO to enable the output drivers. This places the data from the addressed location on the buffered Data Bus where it can be read by the Microprocessor.

The RAM also provides non-volatile storage for the calibration constants and the power-down front-panel settings. When power is applied to the instrument, the Microprocessor reads the calibration constants and generates control voltages to set up the analog circuitry. The front-panel settings that were present at power-off are recalled to return the instrument to that same operating mode.

Battery Circuitry

The Battery circuit composed of BT2570, R2770, CR2770, CR2370, CR2371, and C2470 provides the standby voltage necessary to maintain the contents of the CMOS RAM (U2460). The circuit composed of R2530, U2620C, R2504, and R2506 provides the microprocessor a means of monitoring the battery voltage to detect when the battery needs to be replaced.

Timing Logic

The Timing Logic circuit composed of U2440B, and U2540F generates time- and mode-dependent signals from control signals output from the Microprocessor. The enable (E) signal output from the Microprocessor is a 1.25 MHz square wave used to synchronize oscilloscope functions to processor timing.

Data applied to the Address Bus, Data Bus, and various control signals are allowed to settle (become valid) before any of the addressed devices are enabled. This is accomplished by switching the E signal HI a short time after each processor cycle begins. Inverter U2540F inverts the polarity of the delayed enable signal and enables the Address Decode stage only after the address bus has settled.

Read-Write Latch U2440B is used to delay the processor's read/write signal (R/\overline{W}) from the Microprocessor to meet hold-time requirements of the RAM. At the same time, it generates delayed read and write enabling signals of both polarities to meet the requirements of Buffer U2350 and Latch U2450 (in the Microprocessor Data Bus) and various other devices in the Readout circuitry (diagram 7).

When R/\overline{W} goes LO for a write cycle, Read-Write Latch U2440B is reset, and Q output (pin 9) is held LO, Latch U2450 is in its transparent asynchronously to the buffered Data Bus. At the end of the write cycle, the R/\overline{W} signal goes HI, and the reset to U2440B is removed. The E signal also goes through a negative transition, and data on the Microprocessor data bus lines is latched into U2450. The next positive transition of the 1.25-MHz E signal (1/2 E cycle after the R/\overline{W} sign output, and the \overline{Q} output (pin 8) goes LO. The 1/2 E cycle delay between the time R/\overline{W} goes HI and the time that the Q output of U2440B goes HI keeps Latch U2450 outputs on long enough to meet the data hold time for the RAM. At the end of that delay time, pin 1 of U2450 goes HI, and the Latch outputs are switched to the high-impedance state to isolate it from the buffered Data Bus.

READOUT FRAMING AND INTERRUPT TIMING. Binary counter U2640 is used to generate a readout-framing clock to the Readout circuitry and a real-time interrupt request to the Microprocessor via inverter U2540E. The readout-framing clock is a regular square-wave signal obtained from U2640 pin 14 by dividing the 1.25-MHz E signal by 1024 (2^{10}). This clock tells the readout circuitry to load the next block (subframe) of readout information to be displayed. (See "Readout" description for further information concerning alphanumeric display.) The real-time interrupt request, which occurs every 3.3 ms, is obtained from pin 2 by dividing the E signal by 8192 (2^{13}).

When the real-time request occurs, \overline{IRQ} (pin 4 of U2140) goes LO, and the processor breaks from execution of its mainline program. The Microprocessor first resets Binary Counter U2640 by setting pin 19 of U2301 (diagram 2) HI (to generate the reset), then it resets pin 19 LO to allow the counter to start again. At this time, the Microprocessor sets analog control voltages and reads trigger status from the Display Sequencer (diagram 5). When this is completed, it reverts back to the mainline program.

In addition to the analog control and trigger status update that occurs with each interrupt, on every fifth interrupt cycle, the Microprocessor also scans the front-panel potentiometers. Every tenth interrupt cycle, scanning the front-panel switches and checking the 50- Ω DC inputs for overloads is added to the previously mentioned tasks. If all the tasks are not completed at the end of one interrupt cycle, the real-time interrupt request restarts the analog updates, but as soon as those are accomplished, the Microprocessor will pick up with its additional tasks where it was before the interrupt occurred. This continues until all tasks are completed. If any pot or switch changes are detected, the Microprocessor updates the analog control voltages and the control register data to reflect those changes prior to reverting back to the mainline program instructions.

FRONT-PANEL SCANNING and ANALOG CONTROLS

The Analog Control circuitry (diagram 2), under Microprocessor control, reads the front-panel controls and sets various analog control voltages to reflect these front-panel settings. The calibration constants determined during instrument calibration and the last "stable" front-panel setup conditions are stored in battery backed up RAM. At power-on the stored front panel information is used to return the instrument to its previous state.

Hardware I/O

Data transfer from the Analog Control circuitry to the Microprocessor is via Status Buffer U2220. Data bits applied to the input pins are buffered onto the Data Bus when enabled by the Address Decode circuitry. Via the Status Buffer, the processor is able to (1) determine the settings of front- and rear-panel pots and switches, (2) determine instrument type (2445A or 2455A), (3) determine if a triggered sweep is in progress, and (4) read the contents of the Readout RAM. When disabled, the buffer outputs are switched to high impedance states to isolate them from the buffered Data Bus.

Data transfer from the Microprocessor to the Analog Control circuitry is via registers U2210 and U2310. Via register U2210, the Microprocessor is able to select the pot-scanning multiplexers, turn the trigger LED on and off, and control other hardware via serial control data and the attention strobe. Via register U2310, the processor controls pot selection, ROM addressing, and power down timing.

Front-Panel Switch Scanning

The Front-Panel Switches are arranged in a matrix of ten rows and five columns. Most of the row-column inter-

Theory of Operation—2445A/2455A Service

sections contain a switch. When a switch is closed, one of the row lines is connected to one of the column lines through a diode. Reading of the switches is accomplished by setting a single row line LO and then checking each of the five column lines sequentially to determine if a LO is present (signifying that a switch is closed). After each of the five columns have been checked, the current row line is reset HI and the next row line is set LO for the next column scan cycle. A complete Front-Panel scan consists of all ten row lines LO in sequence and performing a five-column scan for each of the rows.

Row lines are set LO when the microprocessor writes a LO to one of the flip-flops in octal registers U2301 or U2201. The row data placed on the buffered Data Bus by the Microprocessor is clocked into the registers as two, eight-bit words by clocks from the Address Decode circuitry (DAC LSB CLK for the lower eight bits and DAC MSB CLK for the upper eight bits). All eight outputs of register U2201 and two outputs of U2301 drive the ten rows of the front-panel switch matrix (the fifth line of the matrix is not used). Series resistors in the lines limit current flow and eliminate noise problems associated with excessive current flow.

While each row is selected, the processor will scan each of the five column lines in sequence. To scan the columns, the processor increments three data select bits from U2301 that define the column to be checked. Eight-line data selector U2410 connects the associated column line to Status Buffer U2220. As each line is selected, the Microprocessor reads the Status Buffer to determine if the associated switch is open or closed.

In addition to the front-panel switches, the CAL/NO CAL jumper (P501) is checked to determine whether the instrument should be allowed to execute the calibration routines. The levels on U2410 pin 7 and 9 are read by scanning two additional columns at power-up. If the jumper is pulling the CAL bit LO, the operator will be allowed to use the calibration routines stored in firmware. If the NO CAL bit is pulled LO, the calibration routines may not be performed. If the jumper is removed, and neither bit is pulled LO, the Microprocessor is forced into a special diagnostic mode (CYCLE) used to record certain operating failures during long-term testing of the instrument. (See the "Maintenance" section for an explanation of the diagnostic modes.) Removing P501 or switching it between the CAL and NO CAL positions will not be recognized by the Microprocessor until the instrument is powered down and then turned back on.

The resistors in series with the input lines to U2410 are current-limiting resistors that protect the CMOS eight-line data selector from static discharges. The resistors con-

nected from the input lines to the +5 V supply are pull-up resistors for the front-panel column lines.

Digital-to-Analog Converter (DAC)

DAC U2101 is used to set the various analog references in the instrument and is used to determine the settings of the front panel potentiometer. The 12-bit digital values to be converted are written to octal registers U2301 and U2201 for application to the DAC input pins. The DAC then outputs two complementary analog currents that are proportional to the digital input data. (Complementary, in this case, means that the sum of the two output currents is always equal to a fixed value.)

The maximum range of the output currents is established by a voltage-divider network composed of R2010, R2012, R2013, and R2011 connected to the positive and negative reference current inputs of the DAC (pins 14 and 15 respectively). A +10-V reference voltage applied to the DAC through R2013 sets the basic reference current. Resistor R2011 and potentiometer R2010 provide a means to adjust this current over a small range for calibration purposes. The nominal reference current is 1 mA, the DAC full-scale output current is 4 mA. The output currents flow through series resistors R2520 and R2521, connected to the +1.36-V reference, and proportional voltages result.

Pot Scanning

The Pot Scanning circuitry, in conjunction with the DAC, derives digital values for each of the various front-panel potentiometers. Scanning of the pots is accomplished by data selectors U2401, U2501, and U2601. Three bits are written to register U2310 and select the pot to be read. The bits are latched in the register and keep the pot selected until the register is reset. The Microprocessor writes a LO to the inhibit input pin (pin 6) of either U2401, U2501 or U2601 via register U2210 to enable the device. The enabled data selector connects the analog voltage at the wiper of the selected pot to comparator U2510.

Comparator U2510 compares the analog voltage of each pot to the output voltage from the DAC (pin 18). To determine the potentiometer output voltage, the processor performs a binary search routine that changes the output voltage from the DAC in an orderly fashion until it most closely approximates the voltage from the pot.

The conversion algorithm is similar to successive approximation and generates an eight-bit representation of the analog level. When the pot's value is determined, the Microprocessor stores that value in memory. Once all of the pots have been read and the initial value of each has

been stored, the processor uses a shorter routine to determine if any pot setting changes. To do this the DAC output is set to the last known value of the pot (plus and minus a small drift value), and the status bit is read to see that a HI and LO occurs. If within the limits, the processor assumes that the pot setting has not changed and scans the next pot. When the processor detects that a pot setting has changed, it does another binary search routine to find the new value of that pot.

Analog Control

The operating mode and status of the instrument requires that various analog voltages (for controlling instrument functions) be set and updated. The digital values of the controlling voltages are generated by the Microprocessor and converted by the DAC. Analog multiplexers U2521 and U2530 (on diagram 2) and U170 (on diagram 4) route the DAC voltages to sample-and-hold circuits that maintain the control voltages between updates.

The Microprocessor writes three selection bits to register U2301 that directs the DAC output to the appropriate sample-and-hold circuit and charges a capacitor (or capacitors) to the level of the DAC. When the processor disconnects the DAC voltage from the sample-and-hold circuit (by disabling the multiplexer) the capacitor(s) remains charged and holds the control voltage near the level set by the DAC. Due to the extremely high input impedance of the associated operational amplifiers, the charge on the capacitor(s) remains nearly constant between updates.

FRONT-PANEL CONTROLS

The Front Panel is the operator's interface for controlling the user-selectable oscilloscope functions. Along with the crt, it provides visual feedback to the user about the present operating state of the instrument.

Most of the Front-Panel controls (diagram 3) are "cold" controls; i.e., they are not connected directly into the signal path. Therefore, associated circuits are not influenced by the physical parameters (such as capacitance, resistance, and inductance) of the controls. In addition, translating the analog output levels of most of the potentiometers to digital equivalents allows the processor to handle the data in ways that result in a variety of enhanced control features.

To maintain the front-panel operating setup between uses of the instrument, the digitized values of the potentiometers and front-panel switch settings are stored in battery backed up RAM so that when the instrument power is turned off, these control settings are not lost. Then, when

power is next applied, the instrument will power up to the same configuration as when the power was last removed (assuming the settings of the non-digitized pots and switches remain the same).

The Front-Panel Controls also allow the user to initiate and direct the diagnostic routines (and when enabled, the calibration routines) programmed into the read-only memory (ROM). These routines are explained in the Maintenance section of this manual.

Front-Panel Switches

The Front Panel Switches are arranged in a ten-row-by-five-column matrix, with each switch assigned a unique location within the matrix (see Figure 3-3). A closed switch connects a row and a column together through an isolating diode. To detect a switch closure, the switch matrix is scanned once every 32 ms (every tenth Microprocessor interrupt cycle). When scanning, the Microprocessor sequentially sets each individual row line LO. A closed switch enables the LO to be passed through the associated diode to a column line. When the processor checks each of the five column lines associated with the selected row, the LO column is detected. The intersection of the selected row and the detected column uniquely identifies the switch that is closed. Further information about switch scanning is found in the "Front-Panel Scanning" description located in the "Analog Control" discussion.

As each switch is read, the processor compares the present state of the switch to its last-known state (stored in memory) and, if the same, advances to check the next switch. When a switch is detected as having changed, the processor immediately reconfigures the setup conditions to reflect the mode change and stores the new state of the switch in memory. The detected status of the switch on each of the following scan cycles is then compared against the new stored data to determine if the switch changes again. The 32-ms delay between the time a switch is detected as having changed and the next time it is read effectively eliminates the effects of switching noise (switch bounce) that may occur after the switch is actuated.

Front-Panel Pots

The thirteen Front-Panel Potentiometers, READOUT INTENSITY, and INTENSITY are "cold" controls that control the linear functions of the instrument. (SCALE ILLUM and FOCUS are not considered part of the Front-Panel Control circuitry for the purposes of this description.) All are digitized and control their functions indirectly. Data Selectors U2401, U2501, and U2601 in the Analog Control circuitry (diagram 2) route the wiper arm voltage of the pot being read to comparator U2510 where it is compared

Theory of Operation—2445A/2455A Service

with the output of DAC U2101. The processor changes the DAC output until it most closely matches the output voltage of the pot, then stores the digital value of the "match". See the "Pot Scanning" description in the "Analog Control" discussion for further information on the reading of pot values.

Like the switch matrix scanning, the Front-Panel pot scanning routine is performed every 16 ms. When entered, the routine reads the settings of the "last-moved" pot and one "unmoved" pot. Each succeeding scan continues to read the last-moved pot, but a new unmoved pot is read. In this way, each pot is monitored, but most of the scan time is devoted to the pot that is most likely to still be moving (needing continuous updating).

As the initial pot settings are determined, a digital representation of each value is stored in memory. The processor then checks each pot against its last-known value to determine if a pot has moved. If a pot is detected as moving, the processor executes a routine that converts the movement (displacement from last-set value) into a corresponding control voltage.

When producing the actual analog control levels, the processor can manipulate the digital values read for the various pots before sending the output data to the DAC. This allows many of the oscilloscope parameters to vary in an enhanced fashion. The pot data is manipulated by the processor in a manner that produces such features as variable resolution, continuous rotation, fine-resolution backlash, and electrically detented controls.

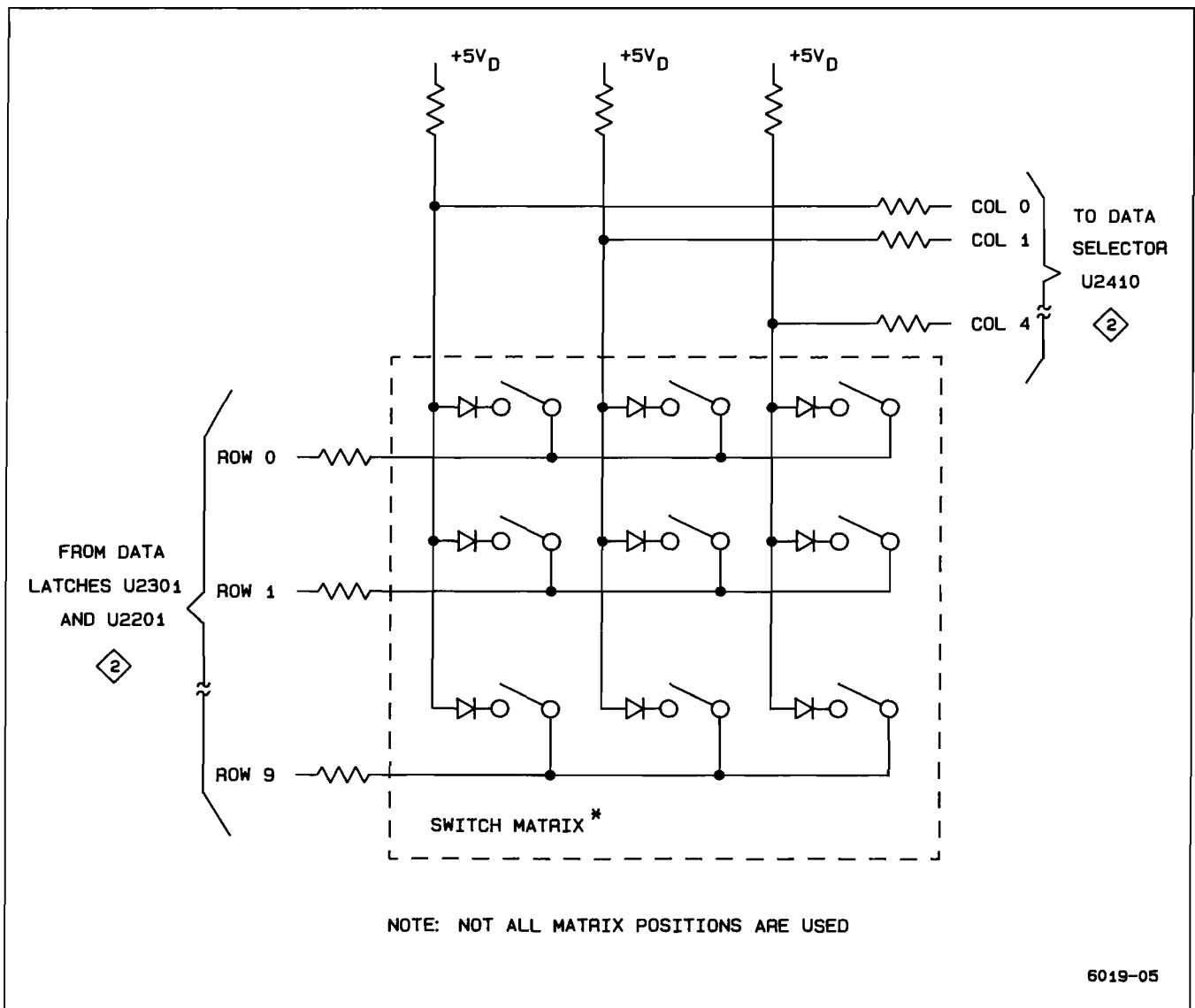

Figure 3-3. Front-panel switch matrix.

With all thirteen Front-Panel Potentiometers, READOUT INTENSITY, and INTENSITY controls, the processor reads the magnitude and direction of pot rotation and produces variable-resolution control voltages. If a pot's direction of rotation changes, the magnitude of the change from the last-set position remains small, or if it was not the last pot moved, a fine-resolution control voltage results. In the fine-resolution range, a given rotation displacement will cause a small control voltage change. The same displacement farther away from the last-set reference will cause a proportionally larger control voltage change, producing a coarse-resolution effect. If the changing pot is the last one moved and the direction of rotation remains the same, the algorithm continues from where it left off during the preceding scan; producing control voltage changes with the same increment as it was last using.

The delta reference controls (Δ REF OR DLY POS and Δ) are continuous-rotation potentiometers. They each consist of two pots ganged together with their wiper arms electrically oriented at 180[degree] apart. As the wiper of one pot is leaving its resistive element, the wiper of the other pot comes onto its element. The Microprocessor has the ability to watch the output voltage from each wiper and when it detects that the controlling wiper is nearing the end of its range, it will switch control over to the other wiper. The routine the processor uses to watch these pots sets the associated control voltage on the basis of relative voltage changes (ΔV) that occur. Switching between the pots to change control to the opposite wiper arm is based on specific voltage levels being sensed.

Sensing specific voltage levels is also used when reading the VOLTS/DIV VAR, SEC/DIV VAR, and HOLDOFF controls. These pots have both a mechanical detent and a processor-generated electrical detent. As one of these controls is moved out of the mechanical detent position, the processor watches the analog voltage changes that occur; but the associated control voltage will not change until a specific voltage level (the electrical detent level) is reached. Once the electrical detent value is exceeded, the processor begins to vary the associated control voltage in response to further pot rotation. When returning to the mechanical position, the electrical detent level is reached first, and the variable voltage action is stopped before the mechanical detent is entered.

Front-Panel Status LEDs

Light-emitting diodes (LEDs) are used to provide visual feedback to the operator about the oscilloscope status and operating mode by backlighting front-panel nomenclature. A 48-bit status word, defining the diodes to be illuminated, is generated by the processor and then serially clocked into the six LED-Status Registers (U3001, U3002, U3003, U3004, U3005, and U3006). The registers hold the selected diodes on until the next update. Whenever the processor detects that a front-panel control has changed

(and a new different status display is required), a new status word is generated and applied to pin 1 of U3002. As each of the bits is clocked into the Q_A position of U3002, the preceding bit is shifted to the next register position. After 48 bits have been clocked into (and 40 bits through) U3002, all six LED-Status registers are full and contain the LED illumination pattern to be displayed to the user. A LO at any Q output of the registers illuminates the corresponding front-panel LED.

The TRIG'D LED is not driven by the LED-Status Register. It is driven by the Analog Control circuitry and illuminated whenever a triggered sweep is in progress.

ATTENUATORS AND PREAMPS

The Attenuators and Preamps circuitry (diagram 4) allows the operator to select the vertical deflection factors. The Microprocessor reads the Channel VOLTS/DIV switches and VOLTS/DIV VAR controls and then digitally switches the attenuator and sets the preamplifier gains accordingly.

CHANNEL 1 AND CHANNEL 2 ATTENUATORS

The Channel 1 and Channel 2 Attenuators are identical in operation, with corresponding circuitry in each channel performing the same function. Therefore, only the Channel 1 circuitry is described.

Input signals from the Channel 1 input connector are routed through an attenuator network by four pairs of magnetic-latch relay contacts. The position of the relays is set by Microprocessor data placed into Auxiliary Control Register U140. Relay buffer U110 provides the necessary drive current to the relays.

Four input coupling modes (1M Ω AC, GND, 1M Ω DC, and 50 Ω DC) and three attenuation factors (1X, \div 10, and \div 100) may be selected by closing different combinations of relay contacts. The three attenuation factors, along with the variable gain factors of the Vertical Preamplifier, are used together to obtain the crt deflection factors. The relays are magnetically latched and once set, remain in position until new attenuator-relay-setting data and strobes are generated. (See the "Auxiliary Control Register" description for a discussion of the relay-latching procedure.)

The 50 Ω termination resistor has a thermal sensor associated with it that produces a dc voltage (CH 1 OVL) proportional to the input power. Should the input power exceed the normal safe-operating level for the 50 Ω DC input, the termination resistor temperature will exceed the

Theory of Operation—2445A/2455A Service

normal operating limit and change the output voltage of the thermal sensor. The amplitude of this dc level is periodically checked via comparator U2510 and DAC U2101 (on diagram 2) and allows the Microprocessor to detect when an overload condition is present. When an overload occurs, the processor switches the input coupling to the 1 M Ω position to prevent damage to the attenuator and displays 50 Ω OVERLOAD on the crt.

Compensating capacitor C105 is adjusted at the time of calibration to normalize input capacitance of the preamplifier to the attenuator.

A probe-coding ring around the BNC input connector passes probe coding information (a resistance to ground) to the Analog Control circuitry for detection of probe attenuation factors. The readout scale factors are set to reflect the detected attenuation factor of the attached probe.

Auxiliary Control Register

The Auxiliary Control Register allows the Microprocessor to control various mode and range dependent functions of the instrument. Included in these functions are: attenuation factors, input coupling, Channel 3 and Channel 4 gains, vertical-bandwidth limiting, and the X-Y display mode.

When the Microprocessor sets the input coupling mode and attenuation factors for Channel 1 and Channel 2, a series of eight, 16-bit control words are serially clocked into shift registers U140 and U150 (eight bits in each register). Each control word is used to set the position of one of the eight attenuator and coupling relays (four relays are in each attenuator assembly). Each control word will have only the bit corresponding to the specific relay contact to be closed set HI. Relay buffers U110 and U130A (for Channel 1) and U120 and U130B (for Channel 2) are Darlington configurations that invert the polarities of all bits. This results in a LO being applied to only the coil lead associated with the contact to be closed; all other coil leads are held HI.

To set a relay once the control word is loaded, the Microprocessor generates a ATTN STRB (attenuator strobe) to U130G pin 7 via R129 and C130. The strobe pulses the output of U130G LO for a short time. This output pulse attempts to turn on both Q130 and Q131 (relay drivers) via their identical base-bias networks. Due to the lower level from the turned on Darlington relay buffer (coupled through the associated coil diode and either CR130 or CR131 to one of the bias networks), one transistor will turn on harder as the ATTN STRB pulse begins to forward bias the transistors. The more positive collector voltage of the transistor turning on harder is fed through the bias

diode (again either CR130 or CR131) to further turn off the opposite transistor. This action results in one transistor being fully on and the other one being fully off. The saturated transistor sources current through the two stacked relay coils to the LO output of either U140 or U150 (current sink) to close the selected contacts. Once set, the magnetic-latch feature will hold the relay set to this position until opposing data is clocked into the Auxiliary Control Register and strobed into the relay. All coil leads for the remaining relays are set HI, and only the selected relay will be set.

To set the seven remaining Attenuator and coupling relays, the sequence just described is repeated seven more times. Whenever the Microprocessor determines that the attenuation factor or input coupling has changed, the entire relay-setting procedure is repeated for all eight relays.

After the coupling and attenuator relays have been latched into position, the Auxiliary Control Register is free to be used for further circuit-controlling tasks. Eight more bits of control data are then clocked into U140 either to enable or disable the following functions: vertical bandwidth limiting (BWL), triggered X-Y mode (TXY), the A and B Sweep Delay Comparators (BDCA and BDCA), and slow-speed intensity limit (SIL); or to alter the Channel 3 and Channel 4 gain factors (GA3 and GA4). Two other bits are clocked into register U150: one to produce the CTC signal and the other to control the scale illumination circuit during SGL SEQ display mode. The CTC control bit is used to enable a sweep-start linearity circuit in the A Sweep circuitry (diagram 5) on the 2 ns and 20 ns per division sweeps.

Analog Control Demultiplexer

When enabled by the Address Decode circuitry, Analog Control Demultiplexer U170 directs the analog levels applied to pin 3 from DAC U2101 (diagram 2) to one of six sample-and-hold circuits. In the Preamplifier circuitry, the sample-and-hold circuits maintain the VAR gain and DC Bal control-voltage levels applied to both the Channel 1 and Channel 2 Preamplifiers U100 and U200 between updates. Two of the Demultiplexers outputs direct analog levels to the Holdoff and Channel 2 Delay offset sample-and-hold circuits (diagram 5). Routing is determined by the three-bit address from register U2301 (diagram 2) applied to Demultiplexer U170 on pins 9, 10, and 11.

Channel 1 Preamplifier

Channel 1 Preamplifier U100 converts the single-ended input signal from the Channel 1 Attenuator to a differential output signal used to drive the Vertical Channel Switch. The device produces either amplification or attenuation in predefined increments, depending on the control data writ-

ten to it from the Microprocessor. The preamp also has provisions for VAR gain, vertical positioning, and a trigger signal pickoff.

The Channel 1 vertical input signal is applied to pin A of Channel 1 Preamplifier U100. Control data from the processor is clocked into the internal control register via pin 22 (CD) by the clock signal applied to pin 23 (\overline{CC}). The data sets the device to have an input-to-output gain ratio of 2, 4, or 10, depending on the VOLTS/DIV control setting.

Two analog control voltages set by DACs modify the differential output signal at pins 9 and 10. The front-panel Channel 1 POSITION control supplies a position signal to U100 pin 17 (via MUX U2530 and sample-and-hold U2430 and C2432) that vertically positions the Channel 1 display on the CRT. A DC Bal signal is applied to pin 2 of U100 from MUX U170 via the sample-and-hold circuit composed of U160A and C177. This DC BAL signal is a dc offset-null level that is determined during the automatic DC Bal procedure. The offset value is stored as a calibration constant in RAM and is recalled at regular intervals to set the DC Bal level, holding the Preamplifier in a dc balanced condition.

The Channel 1 VOLTS/DIV VAR control is monitored by the Microprocessor during the front-panel scanning routine. When the processor has determined where the VOLTS/DIV VAR control is positioned, it causes DAC U2101 (diagram 2) to produce a corresponding control level and routes it to the VAR gain sample-and-hold circuit composed of U160D, C179, and associated components. The control voltage at the output of U160D (pin 14) sets the variable gain of the Preamplifier.

A pickoff amplifier internal to U100 conditions the trigger signal and provides the proper signal level at pin 15 to drive the A/B Trigger Generator (U500, diagram 5). The pickoff point for the trigger signal is prior to the addition of the vertical position offset, so the position of the signal on the crt has no effect on the trigger operation. However, the pickoff point is after the DC Bal and Variable gain signals have been added to the signal so both of these functions will affect trigger operation.

Common-mode signals are rejected from the trigger signal by the circuitry composed of operation amplifier U450B and associated components. The inverting input of U450B (pin 6) is connected to the common-mode point between APO+ (pin 12) and TPO- (pin 15) of U100. Any common-mode signals present are inverted and applied to a common-mode point between R451 and R453 to cancel the signals from the differential output. A filter network composed of LR 180 and the built-in circuit board capacitor (5.6 pF) reduces trigger noise susceptibility. Trigger sig-

nals for options are obtained from J100.

The Channel 1 input signal used to provide the horizontal deflection for the X-Y displays is obtained from U100 pin 11. The components between pin 11 and the Horizontal Output Amplifier provide phase compensation of the signal. During instrument calibration, the delay produced by C115, C116, L115, R115, and variable capacitor C118 is matched to the 78-ns delay of the vertical delay line (DL100, diagram 6).

Channel 2 Preamplifier

Operation of Channel 2 Preamplifier U200 is nearly identical to that of the Channel 1 Preamplifier just described. The exceptions are that the output polarity of the Channel 2 signal may be either normal or inverted and that the signal obtained from the BPO+ output (pin 11) is conditioned differently for a different purpose than in the Channel 1 Preamplifier circuitry.

Inverting the Channel 2 signal for the CH 2 INVERT feature is accomplished by biasing on different amplifiers. The control data clocked into the internal control register from pin 22 sets up the necessary switching.

The Channel 2 BPO+ signal at U200 pin 11 provides an accurate representation of the Channel 2 signal at the rear-panel CH 2 OUT connector.

Channel 3 and Channel 4 Preamplifier

The functions provided by the Channel 3 and Channel 4 Preamplifier are similar to those provided by the Channel 1 and Channel 2 Preamplifiers. The single-ended CH 3 and CH 4 input signals are converted to differential signals, and vertical gain and vertical positioning are added to the output signals. Trigger pickoff signals are generated for both channels and are routed to the Trigger hybrid.

Channel 3 and Channel 4 gains may be either 0.1 volt per division or 0.5 volt per division. The logic levels of control bits applied to U300 pin 30 (GA3) and pin 31 (GA4) from Auxiliary Control Register U140 sets the gain of the Channel 3 and Channel 4 preamplifiers respectively. Vertical positioning of the Channel 3 and Channel 4 signals on the crt is controlled by the voltage levels applied to pin 29 (POS3) and pin 32 (POS4) from the front-panel CH 3 and CH 4 POSITION potentiometers (via MUX U2530 and sample-and-hold amplifiers U2430C and C2333 and U2430D and C2332).

Dc offsets in the output signal due to any tracking differences between the +5-V and the -5-V supply to

mode. In most cases, the trigger selection does not change after it has been set unless a front-panel trigger control is changed. An exception is that in VERT TRIGGER MODE, the trigger source tracks the sequencing of the vertical channels (unless AUTO LVL MODE, or CHOP VERTICAL MODE is also selected). Trigger source selection lines are changed only during trigger holdoff time between sweeps.

Fifty-five bits of serial data from the processor defining the instrument's operating sequence are applied to the Display Sequencer data input, pin 25. The data string is clocked into U650 to the internal control register by the processor-generated control clock applied to pin 24. The data string is organized in several fields, with each field defining the operating mode of one specific instrument function.

Display Sequencer U650 controls the various functions defined by the data fields by setting the levels of the associated control lines. The functions and controlling signal lines for each function are as follows:

VERTICAL DISPLAY SELECTION. CH 1, CH 2, CH 3, CH 4, ADD, and Readout Y signals are selected by the $\overline{VS1}$, $\overline{VS2}$, $\overline{VS3}$, and $\overline{VS4}$ control signals. See the Vertical Channel Switch description for further information.

HORIZONTAL DISPLAY SELECTION. A Sweep, B Sweep, CH 1 (for X-Y displays) and Readout X are selected by the \overline{HSA} and \overline{HSB} control signals. See the Horizontal Output Amplifier description for further information.

TRIGGER SOURCE SELECTION. CH 1, CH 2, CH 3, CH 4, ADD, Line, and a sample of the vertical output signal (for calibration purposes only) are selectable as the Trigger SOURCE by the $\overline{SR0A}$, $\overline{SR1A}$, $\overline{SR2A}$, $\overline{SR0B}$, $\overline{SR1B}$, and $\overline{SR2B}$ control lines (pins 28, 27, 29, 32, 31, and 30 respectively). See the A/B Trigger description for further information.

TRIGGER HOLDOFF. Sweep recovery time and the circuit initialization time required when front-panel controls are changed are controlled by the THO (trigger holdoff) signal.

DELTA TIME (Δt) DELAY SELECTION. DLY REF 0 or DLY REF 1 is selected by the \overline{DS} (delay select) signal.

TRIGGER and SWEEP ACTIVITY (STATUS). The activity of the Trigger and Sweep circuits, as indicated by the SGA, SGB, TSA, and TSB lines, is reported to the

Microprocessor via the TSO (trigger status output) line when clocked by the TSS (trigger status strobe) signal.

INTENSITY CONTROL. The readout intensity, display intensity, and display intensity compensation are controlled by the BRIGHT output level.

DISPLAY BLANKING. Display blanking for CHOP VERTICAL MODE, Readout transitions, and front-panel control changes is controlled by the BLANK output.

READOUT CONTROL. The vertical selection, horizontal selection, and intensity controls are all set to their readout modes either at the end of an A Sweep (\overline{SGA} goes HI) or in response to a readout request (\overline{ROR}) from the Readout circuitry (diagram 7). While in the readout mode, the BLANK control signal is driven by the readout blank (\overline{ROB}) input signal on pin 5 (also from the Readout circuitry). The readout active line (\overline{ROA} , pin 6), when set LO, tells the Readout circuitry that readout dots may be displayed if necessary. The \overline{ROA} signal is always set LO at the start of the trigger holdoff time following sweeps, and it is held there until the holdoff time is almost over. This allows the majority of holdoff time to be used for displaying readout dots. The Display Sequencer will switch the \overline{ROA} signal back to HI before the end of holdoff so that the readout display does not interfere with display of the vertical signal at the triggering event.

TRACE SEPARATION. Vertical separation between the A Sweep trace and the B Sweep traces (for alternate horizontal sweep displays), and between the reference B Sweep trace and the delta B Sweep trace (when delta time is selected in B Sweep only mode), is enabled by the TS1+TS2 output.

X10 HORIZONTAL MAGNIFICATION. Horizontal X10 magnification is controlled by the \overline{MAG} output.

CALIBRATOR TIMING. The 5-Hz to 5-MHz drive signal to the Calibrator circuitry is provided by the CT output.

DELAY GATE OPERATION. Analog Switches U850B and U850C select the delay references for each sweep. Depending on the display mode and point in the display sequence, the DS control signal (U650 pin 40) routes one of the two analog delay references through U850B and U850C to the two sweep hybrids. The selected reference level is compared against the changing sweep ramp voltages to generate the delay gates that control each sweep's functions.

After an A Sweep has been initiated by a trigger, a delay gate circuit within U700 compares the A Sweep

Theory of Operation—2445A/2455A Service

ramp voltage to the selected delay reference. When the sweep ramp reaches the delay reference level, the DG (delay gate) output goes LO, enabling the B trigger portion of U500 and B Sweep hybrid U900. Then, when B triggering occurs (for TRIG AFT DLY mode), the A/B Trigger hybrid sets the \overline{TGB} (trigger gate B) signal LO, initiating the B Sweep. In RUN AFT DLY mode, however, the \overline{TGB} signal to U900 is held LO, and the B Sweep is initiated at the end of the A Sweep delay time when the A Sweep delay gate goes LO.

STATUS MONITORING. As the Display Sequencer controls the display system in real time, it continually monitors the trigger and sweep operations and updates the internal trigger status register accordingly. The Microprocessor checks the contents of this register every 3.3 ms to determine the current status of the trigger and sweep circuitry. The Microprocessor reads the trigger status register by generating a series of trigger status strobe (\overline{TSS}) pulses (U650 pin 19) to serially clock the contents of the register out to the TSO (trigger status output) line and onto the Data Bus (via Status Buffer U2220 on diagram 2). The system status information obtained by this check is used for AUTO LVL triggering, AUTO free-run triggering, detecting the completion of all sweeps in a SGL SEQ display, and during instrument calibration.

INTENSITY CONTROL. The Display Sequencer controls the intensity for both sweep and readout displays. The analog levels at pins 22 and 23 determine the basic intensity level of the displays. Two internally generated DAC currents (developed by multiplying the IREF current at pin 20 by two processor-generated numbers stored internally) are added to the basic intensity level currents to produce the display intensity seen on the crt (see Table 3-1). The two DAC currents added to the INTENSITY current are dependent on sweep speed, number of channels being displayed, and whether or not the X10 MAG feature is in use. These added currents increase crt beam current and hold the display intensity somewhat constant under the varying display conditions. The resulting current is applied to Z-Axis Amplifier U950 (diagram 6) from the BRIGHT output of the Display Sequencer (pin 21).

To produce the intensified zone on the A Sweep trace for A intensified by B Sweep displays, an additional current is added to the crt drive signal by the Z-Axis Amplifier during the concurrence of the SGAZ and SGBZ (sweep gate A and B z-axis) signals.

The readout intensity (ROI) level, controlled from the front-panel READOUT INTENSITY pot (via MUX U2530 and sample-and-hold U2630A and C2732). The Microprocessor increases readout intensity when the pot is rotated

Table 3-1
Intensity Control

Type of Display	Horizontal Selects		Resulting Current at BRIGHT Output
	\overline{HSA}	\overline{HSB}	
X/Y	LO	LO	DI (display intensity) only
A Sweep	LO	HI	DI + A SWP DAC current
B Sweep	HI	LO	DI + B SWP DAC current
Readout	HI	HI	ROI (readout intensity) only

either direction from center. Minimum readout intensity current occurs at the midpoint of the READOUT INTENSITY pot rotation. The Microprocessor also detects to which side of center the READOUT INTENSITY control is set. Depending on the status received, the processor sets up the Readout circuitry (diagram 7) to display either all of the readout information or just the "delta type" readouts.

Blanking of the crt display during CHOP VERTICAL MODE displays or when switching between dot positions in the readout displays is controlled by the Display Sequencer's BLANK output (pin 3). When the signal is LO, the crt z-axis is turned on to the selected intensity level; when HI, the crt display is blanked.

READOUT CONTROL. The readout request signal (\overline{ROR}), the readout active signal (\overline{ROA}), and the readout blank signal (\overline{ROB}) control readout displays. During the first part of the holdoff time, up until one or two holdoff ramps before holdoff time ends (dependent on the sweep rate), the Display Sequencer sets the \overline{ROA} signal line LO. While the \overline{ROA} line is LO, the Readout circuitry may display readout character dots if necessary. During readout displays, the horizontal and vertical select signals (\overline{HSA} , \overline{HSB} , $\overline{VS1}$, $\overline{VS2}$, $\overline{VS3}$, and $\overline{VS4}$) are all set HI. This deselected the waveform-related sweep and deflection signals and gives display control to the Readout circuitry. While readout information or cursors are being displayed, the BLANK output signal (pin 3) is controlled by the readout blank (\overline{ROB}) signal from the Readout circuitry, and the readout intensity (ROI) signal pin (pin 23) controls the BRIGHT output level.

During holdoff, the Display Sequencer always sets the readout active (\overline{ROA}) line LO. As previously described, setting the \overline{ROA} signal LO allows the Readout circuitry to display readout dots. In some settings of the SEC/DIV switch, with adequate trigger rates, holdoff time is provided for the Readout circuitry to display all the readout information without causing noticeable display flicker.

In those cases where the holdoff time is insufficient to prevent flicker, a portion of the Readout circuitry will request display control by setting the readout request ($\overline{\text{ROR}}$) signal LO. The Display Sequencer recognizes all readout requests immediately and switches the horizontal and vertical select lines to the readout display mode. The Readout circuitry displays one readout dot and then resets the readout request HI to switch back to the display of waveforms. Readout requests occur as required during sweep times to keep the readout display caught up. (See "Readout" description for further information).

TRACE SEPARATION. The TRACE SEP feature is used to position the alternate B Delayed Sweep trace downward from the A Sweep when Alternate Horizontal Display Mode (TURN-ALT) is active. It is also used when either the Δt or $1/\Delta t$ measurement function is used with B Sweep only displays. In the latter case, the TRACE SEP control vertically positions the trace(s) associated with the Δ control.

When the Display Sequencer determines that trace separation should be active, the LO TSIN level at pin 7 is routed to pins 9 and 8, the TS1 and TS2 outputs (connected together). This LO output turns off transistor Q600 (diagram 6), thereby enabling the trace separation voltage from the front-panel TRACE SEP pot (via MUX U2530 and sample-and-hold U2630C and C2631) to be applied to pin 42 of Vertical Output Amplifier U600. To disable the trace separation function, the Display Sequencer sets the TS1 + TS2 control line HI, turning on Q600 and shunting the trace separation signal to ground.

X10 MAG SELECT. The $\overline{\text{MAG}}$ (sweep magnifier) output (pin 39) drives the magnifier control input (pin 14) of Horizontal Output hybrid U800 and the select input (pin 9) of analog switch U860C (diagram 6). Analog switch U860C routes a magnifier gain-control voltage to the Horizontal Amplifier to set the horizontal gain for the X10 magnified displays.

CH 2 DELAY OFFSET. The $\overline{\text{VS2}}$ (vertical select, channel 2) output applied to analog switch U860B at pin 10 routes a calibrated offset voltage from sample-and-hold buffer U165D to both sweep hybrids when the Channel 2 vertical signal is being displayed. The offset voltage is used to eliminate the apparent propagation delay between the Channel 2 and the Channel 1 (or CH 2 and either one of the other channels). A step in the calibration procedure allows use of the front-panel Channel 2 Delay Offset feature to be either enabled or disabled. When enabled, the Channel 2 offset may be adjusted up to ± 500 ps (with respect to Channel 1) using the Δ control.

CALIBRATOR TIMING. The Calibrator timing signal (CT) from the Display Sequencer is generated by an internal counter. The counter divides the 5-MHz clock input at pin TC (timing clock) by a value that is a function of sweep speed. The resulting square-wave output signal drives the Calibrator circuit. For ease of sweep rate verification, the Calibrator signal provides a display of five complete cycles on the crt at sweep speeds from 100 ms per division to $0.1 \mu\text{s}$ per division. Below 100 ms per division, the Calibrator output frequency remains at 5 Hz; and above $0.1 \mu\text{s}$ per division, the Calibrator frequency remains at 5 MHz.

When chopping between vertical channels, the Display Sequencer adds a 200-ns skew at the end of some sweeps to desynchronize the chop frequency from the sweep speed (to prevent the sweep from locking onto the chop frequency). Due to this, the Calibrator signal has an irregular pulse repetition characteristic between sweeps. This will not be apparent when observing the Calibrator signal on the instrument crt since the skew is synchronized to the sweep, but may be observed when the Calibrator output signal is used with other instrumentation. The skew can be eliminated by setting the instrument to SGL SEQ Mode (to shut off the sweeps).

Holdoff Circuitry

The holdoff circuit, used to delay the start of a sweep until all circuits have recovered from the previous sweep, is made up of U165C, Q154, Q155, and associated components. Operational Amplifier U165C and capacitor C180 form a sample-and-hold buffer used to set the charging current for holdoff-ramp integrating capacitor C171. A control voltage from digital-to-analog converter (DAC) U2201 (diagram 2) via multiplexer U170 (diagram 4) is stored on C180. The stored voltage level sets the base voltage for both Q154 and Q155 via amplifier U165C. Transistors Q154 and Q155 form a current-mirror with nearly equal collector currents. Transistor Q154 is a current-to-voltage converter that provides negative feedback to U165C, setting loop gain. Transistor Q155 acts as a constant-current source that charges integrating capacitor C171, producing a linear holdoff ramp.

A comparator circuit in U650 detects when the ramp crosses a predefined threshold voltage (approximately +3 V). When the threshold is reached, pin 10 of U650 (HRR) goes LO and the integrating capacitor is discharged. At that same time, an internal counter that keeps track of the holdoff ramp cycles is incremented. The ramps continue to be generated and reset until the holdoff ramp counter has counted the number of ramp cycles defined by the sweep-rate-dependent holdoff data field stored in the Display Sequencer control register. At all sweep speeds except 5 ns per division, the count is at least two holdoff ramp cycles. The front-panel variable HOLDOFF control affects holdoff time by varying the HOLDOFF control voltage to

Theory of Operation—2445A/2455A Service

U165C (from the DAC), changing the charging rate of integrating capacitor C171.

When holdoff time requirements are met (determined by the number of ramps counted), the Display Sequencer sets the THO (trigger holdoff) signal LO. This enables both the A Sweep hybrid (U700) and the A Trigger circuitry in U500. The Trigger circuit begins monitoring the selected trigger source line and, when a triggering event is detected that meets the triggering requirements defined by the stored control data, initiates the A Sweep and sets the TSA (trigger status, A Sweep) line to Display Sequencer U650 LO (indicating that the A Sweep has been triggered).

As the A Sweep circuit (U700) responds to the trigger, it sets the SGA (sweep gate A) line LO (via U980A) indicating that an A Sweep is in progress. After the sweep has run to completion, U700 sets the SGA line HI signaling the end of sweep. The Display Sequencer then sets the THO line HI, resetting A/B Trigger hybrid U500 and A Sweep hybrid U700 in preparation for the next sweep.

Triggers

The A/B Trigger hybrid (U500) and associated circuitry select the triggering signal source for each horizontal sweep as directed by the Display Sequencer. When the proper triggering criteria to initiate a sweep are detected, a triggering gate signal is produced to start the selected sweep.

Control data from the processor defining trigger mode, coupling, and slope parameters for each trigger is clocked into two storage registers internal to U500 by the A TRIG CLK signal on pin 23 (\overline{CCA}) and the B TRIG CLK signal on pin 47 (\overline{CCB}). The Display Sequencer selects the A trigger source with the $\overline{SR0A}$, $\overline{SR1A}$, and $\overline{SR2A}$ signal lines; the B trigger source is selected using the $\overline{SR0B}$, $\overline{SR1B}$, and $\overline{SR2B}$ signal lines. Table 3-2 illustrates trigger source selection.

To initiate the A Sweep, the trigger hybrid compares the selected signal to the analog trigger level input at pin 13, the TLA (trigger level A). B trigger signals are compared to the TLB (trigger level B) signal at pin 37 when trigger B Sweeps are required. When the proper trigger signal is detected, U500 outputs a trigger gate (\overline{TGA} or \overline{TGB}) to the appropriate sweep circuit to initiate that sweep.

When an A Sweep is initiated, the trigger-status line (\overline{TSA}) (trigger status A, U500 pin 20) goes LO to signal the Display sequencer that a trigger has occurred. Until the sweep is completed, the \overline{TGA} signal on pin 18 (or \overline{TGB} signal on pin 42 for B Sweeps) remains LO. After the A

Table 3-2
Trigger Source Selection

Select Inputs			Trigger Source
$\overline{SR2A(B)}$	$\overline{SR1A(B)}$	$\overline{SR0A(B)}$	
H	H	L	CH 1
H	L	H	CH 2
H	L	L	ADD
L	H	L	CH 3
L	L	H	CH 4
H	H	H	LINE (or BWLB) ^a

^aDuring calibration routines from the Diagnostic Monitor.

Sweep is completed, the A Sweep Gate (\overline{SGA}) from A Sweep hybrid U700 (via U980A) will go HI, causing the Display Sequencer to set its THO (trigger holdoff) line (pin 13) HI. This resets the sweep hybrid and the trigger hybrid in preparation for the next trigger event.

The B Trigger Holdoff input (THOB, U500 pin 39) is held HI (keeping the B Trigger reset) until the A Sweep Delay Gate (DG, U700 pin 41) goes LO (see the following A Sweep description). When DG goes LO, the B Trigger portion of U500 is enabled. The B Sweep Trigger functions in a manner similar to that of the A Sweep Trigger just described.

A Sweep

When properly triggered, the A Sweep circuit generates linear sweep ramps of selectable slopes. When amplified, these ramp signals horizontally sweep the crt beam across the face of the crt. The A Sweep circuitry consists of U700, Q709, Q710, Q741, U910B, U980A, and associated components.

The A Sweep ramp signal is derived by charging one of several selectable capacitors from a programmable constant-current source. Capacitor selection depends on the sweep-rate-dependent control data (CD) on pin 29 that is clocked into A Sweep hybrid U700 by the A SWP CLK on pin 28 (\overline{CC}). This sweep-rate data causes some internal logic to select either hybrid-mounted capacitors CT0 or CT1 or capacitor C708 at the CT2 (timing capacitor two) pin. An additional capacitor, C709, may be selected (via Q709 and Q710) if the control data asserts the TCS (timing capacitor select) signal on pin 9. TCS will be HI for A

Sweep speeds slower than 1 ms per division. Capacitor C707 and associated circuitry form a linearity compensation circuit.

The constant current to charge the selected capacitor is derived from the DAC-controlled voltage, A TIM REF (A timing reference), generated on the Control Board. The ITREF input (U700 pin 24) is held at zero volts by an internal programmable current-mirror circuit at that input (see Figure 3-5). The A TIM REF voltage is applied to the current mirror via series resistors R723 and R724 to establish the input reference current (ITREF). The output of this current mirror is related to the input reference current by a multiple "M" that is set by a control data field stored in the internal control register of U700. The derived output current ($M \times ITREF$) is connected to another programmable current-mirror circuit, U910B, external to the hybrid. The output of U910B provides the actual charging current and is a control-data-selected multiple of the $M \times ITREF$ current.

At the time of calibration, the processor will vary the ITREF input current until the slope of the output ramp for specific current-mirror/timing capacitor combinations is precisely set. The values of A TIM REF at these settings allow the processor to precisely calculate the characteristics of the current-mirror circuits at their various multiplica-

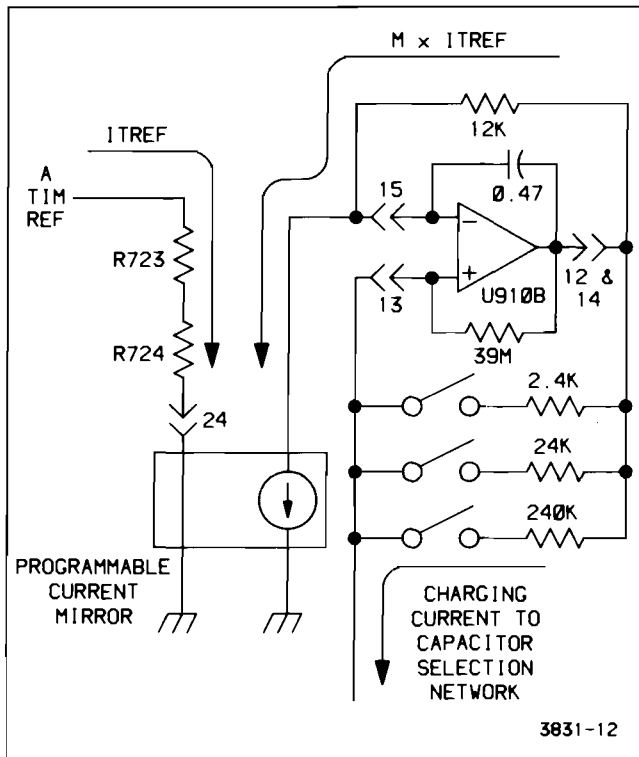

Figure 3-5. Sweep generator.

tion factors and the charging characteristics of the timing capacitors. These values are stored as calibration constants in nonvolatile memory (RAM U2460, diagram 1).

Once the calibration constants are set, any setting of the SEC/DIV switch causes the Microprocessor to recall the associated calibration constants from RAM. The processor then calculates the proper value of A TIM REF based on the selected timing capacitor and the current-mirror multiplication factors.

If the SEC/DIV VAR control is out of the calibrated detent position, the processor will decrease the A TIM REF voltage from the maximum, in-detent value by an amount proportional to the position setting of the VAR control. At the maximum, fully counterclockwise setting of the VAR control, the ITREF current is one-third that of the normal, in-detent current.

For A Sweep hybrid U700 to initiate a sweep at the selected rate, the AUXTRIG (auxiliary trigger) input (pin 3), the THO (trigger holdoff) line from the Display Sequencer (on pin 1), and the TRIG (trigger) line from the trigger hybrid (on pin 2) must all be LO. With these three inputs LO, the A SWEEP ramp begins, and the sweep gate (\overline{SG}) output (pin 45) goes LO. The buffered sweep gate signal (\overline{SGA}) at the output of U980A returns to the Display Sequencer through R981 to indicate that the A Sweep is active. The sweep gate signal is used by various other circuits for their timing activities and is held LO until the A SWEEP ramp ends. The buffered (negative) sweep gate is inverted and routed to the rear-panel A GATE output connector via U975B.

Diodes CR752 and CR753 and associated components form a charging network that permits delaying the timing of the end-of-A-Sweep gate signal (\overline{SGAZ}) for B Sweep displays. For normal A Sweep operation with the \overline{SGBZ} signal HI, the \overline{SGAZ} signal will end quickly, since the capacitance associated with Z-Axis hybrid U950 input (diagram 6) will be charged positively through both R753 and R754. For B Sweep operation (\overline{SGBZ} is LO), the end of the \overline{SGAZ} gate signal will be delayed slightly (with respect to the normal sweep gate) since charging of the Z-Axis input capacitance will be at a slower rate through R754 only. This allows more of the B Sweep to be displayed than would otherwise be possible.

The A Sweep Delay Gate (DG) signal acts as the trigger holdoff (THO) signal for the B Sweep and the B Trigger circuitry. It is generated by comparing the A SWEEP ramp voltage to the selected delay reference (DR) level from analog switch U850C. As the ramp voltage crosses the delay reference level, the delay gate (DG) output signal goes LO, removing the HI THO level to the B

Theory of Operation—2445A/2455A Service

Sweep. This enables the B Sweep to run immediately in RUN AFT DLY B Trigger Mode or, when in TRIG AFT DLY B Trigger Mode, enables the B Sweep to run when a B triggering event occurs.

The BDCA (A Sweep bypass-delay comparator) input (U700 pin 39) is a data bit from Auxiliary Control Register U140 (diagram 4) that, when HI, sets the A Sweep DG output LO at the beginning of the A Sweep. This enables the B Sweep to run immediately at the start of the A Sweep and is used for calibration purposes and for options.

The capacitive load (part of the etched-circuit board) at the RDA (retrace delay adjust) input (U700 pin 4) is used to delay the retrace of the sweep until the Z-Axis drive is fully turned off in response to the SGAZ gate going HI. This delay prevents any part of the retrace from being seen.

B Sweep

Operation of B Sweep hybrid U900 is similar to that just described for the A Sweep with the following exceptions: The THO input (and thus sweep enabling) is controlled by the A Sweep hybrid and not the Display Sequencer (see the preceding A Sweep description). The timing capacitor select output, TCS, is not used, and only three timing capacitors are selectable (two on the B Sweep hybrid at CT0 and CT1 and one externally at CT2). Unlike the A Sweep, the delay reference (DR) input (U900 pin 37) and the B Sweep bypass-delay comparator signal (BDCB) input (at U900 pin 39) are used only for factory calibration.

Calibrator

The Calibrator circuit, composed of Q550, U165B, U550A, B, C, and D, and associated components, generates a square wave output of precise amplitude and frequency characteristics. The CALIBRATOR signal provided at the front-panel output connector is useful for adjusting probe compensation and verifying VOLTS/DIV, SEC/DIV, and Δt (delta time) calibration. Output frequency is controlled by the Display Sequencer and is set to display five cycles across the ten crt graticule divisions at sweep speed settings from 100 ns per division to 100 ms per division. This feature allows quick and easy verification of the sweep rates. The Calibrator circuitry is essentially a voltage regulator that is alternately switched on and off, producing the square-wave output signal.

When the timing signal (CT) from the Display Sequencer to the base of U550D is LO, U550C (configured as a diode) is forward biased, shunting bias current away

from Q550, keeping it turned off. When transistor Q550 is off, the front-panel CAL OUT connector is pulled to ground potential through R558, setting the lower limit of the CALIBRATOR output signal.

As the CAL signal goes from LO to HI, the emitter of U550D is pulled HI to reverse bias U550C. Bias current for Q550 is established, and the transistor is turned on. The voltage at the emitter of Q550 rises to a level of +2.4 volts, determined by the voltage regulator composed of U165B, U550A, U550B, and associated components. This regulated level is applied to the front-panel CALIBRATOR connector through a voltage-divider network composed of R557 and R558. This produces an output voltage of 400 mV with an effective output impedance of 50 Ω .

Since the frequency of the CALIBRATOR signal is controlled by the same divider chain that controls operation of the vertical chopping rate, the intentional 200-ns shift added to the chop signal at the end of some sweeps (to desynchronize the chopping rate from the sweep rate) shows up on the CALIBRATOR signal as an irregular-width pulse. This shift is not apparent when viewing the CALIBRATOR signal on the instrument providing the signal (since the skew occurs during sweep-retrace time), but it should be taken into account when using the CALIBRATOR signal with other instrumentation. The skew can be eliminated from the signal by setting the instrument TRIGGER MODE to SGL SEQ (to shut off the sweeps).

VERTICAL CHANNEL SWITCH AND OUTPUT AMPLIFIERS

The Vertical Channel Switch (diagram 6) selects the signal source for vertical deflection of the crt beam. The Vertical, Horizontal, and Z-Axis output amplifiers provide the signal amplification necessary to drive the crt.

Vertical Channel Switch

The Vertical Channel Switch consists of hybrid Channel Switch U400, that selects one of the vertical signals for application to the Vertical Output Amplifier, and a combined switch/amplifier circuit that converts the single-ended readout vertical signal into a differential signal for application to the Channel Switch.

Channel selection is controlled by the Display Sequencer $\overline{VS1}$ through $\overline{VS4}$ signals applied to the vertical channel selection pins (pin 24, pin 25, pin 13, and pin 14 respectively). (See Table 3-3 for the Vertical Display Selection. When a vertical select line is LO, the associated input signal pins are connected to the differential output (+OUT, pin 11 and -OUT, pin 3). The CH 5 input signal (Readout

Table 3-3
Vertical Display Selection

Select Inputs				Vertical Display
$\overline{VS1}$	$\overline{VS2}$	$\overline{VS3}$	$\overline{VS4}$	
L	H	H	H	CH 1
H	L	H	H	CH 2
L	L	H	H	ADD
H	H	L	L	CH 3
H	H	H	L	CH 4
H	H	H	H	Readout (Y)

Vertical) is added to the output whenever both the $\overline{VS3}$ and contain readout information when the readout select logic (U975A and U975C) detects that the Display Sequencer has set both the Horizontal Select signals (\overline{HSA} and \overline{HSB}) HI (readout selected).

READOUT SWITCH/AMPLIFIER. Transistors U485A, U485B, U485C, U485D, and U475C, along with their associated components, make up an analog switch circuit that routes either the readout vertical signal at the base of U485A or the ground reference at the base of U485C to the output at the emitter of U475C. The signal selected depends on the complementary voltages applied to the emitter junctions of the two emitter-coupled transistor pairs, U485A and B and U485C and D. The selection voltages are developed by voltage-divider networks on the complementary logic outputs of U975A and U975C.

When readout information is to be displayed, the horizontal select inputs to U980B and U980C go HI and the output of NAND-gate U975C goes LO. The LO applied to the divider network of R498, R484, and R471 pulls the anode of CR484 low enough to reverse bias it. This forward biases the emitter-coupled pair U485A and B via R483. NAND-gate U975A inverts the LO and applies a HI to the junction of R497 and R485. The HI forward biases CR485, and the emitters of U485C and D are pulled to a level in excess of +2 V, reverse biasing the transistor pair. With U485C and D reverse biased, the ground reference level at the base of U485C is isolated from the output, while the readout vertical information is allowed to pass through the forward-biased transistor pair.

When readout information is not being displayed, a HI is present at the output of NAND-gate U975C. The HI forward biases CR484 and, when inverted by U975A, reverse

biases CR485. With the biasing conditions reversed, the transistor pair of U485C and D becomes forward biased and U485A and B becomes reverse biased. The ground reference level present at the base of U485C is coupled to the output, while the readout vertical signal is isolated.

The output signal (either the readout vertical signal or the ground reference level) is applied to the CH5+ input of Channel Switch U400 via R495 and R412. The inverting amplifier circuit composed of U475A, U475B, U475D, and associated components inverts the readout vertical signal for application to the CH5- input. The amplifier is an inverting unity-gain configuration with transistors U475A and U475B connected as an emitter-coupled pair. The base of U475A is referenced to ground through R482. The base of U475B is pulled to the same level by the negative feedback from emitter-follower U475D through R478. The noninverted signal is applied to the base of U475B through R492 and will attempt to increase or decrease the current to the base of U475B, depending on the amplitude and polarity of the signal. However, the negative feedback from the collector of U475B (via U475D and R478) will hold the base of U475B at the ground reference level. The feedback current through R478 develops a voltage drop across R478 that is equal in amplitude but opposite in polarity to the noninverted vertical readout signal. The inverted readout signal is applied to the Channel Switch on pin 2 (CH5-) via R476 and R402.

The HF ADJ (high-frequency adjust) potentiometer R417 (2455A only) and resistor R416 (connected to pin 16) adjust the high-frequency response of the Channel Switch hybrid.

Vertical Output Amplifier

Vertical Output Amplifier U600 is a hybrid device that provides the final amplification of the selected vertical signal, raising it to the level required to drive the crt deflection plates. Vertical deflection signals from the Vertical Channel Switch are delayed approximately 78 ns by Delay Line DL100. This delay allows the Sweep and Z-Axis circuits to turn on before the triggering event begins vertical deflection of the crt beam, thereby permitting the operator to view the triggering event. The bridged-T network, composed of inductors and capacitors built into the circuit board, corrects phase-distortion introduced by the delay line. The RLC networks connected between the output pins of U400 are adjusted during calibration to obtain the correct overall high-frequency response of the vertical deflection system. The vertical signal from the Delay Line is applied to pins 10 and 3 of U600. The RL network connected between pins 8 and 5 (COMPA and COMPB) of U600 compensates the signal for the skin-effect losses associated with the delay line.

Amplifier gain and vertical centering are adjusted by R638 and R639 respectively, primarily to match the

Theory of Operation—2445A/2455A Service

amplifier hybrid to the crt installed in the instrument. The Dynamic Centering circuit sinks an intensity-dependent correction current away from the vertical centering input at pin 39. The correction signal holds the vertical centering stable over a wide range of varying display intensities. Readout jitter adjustment pot R618 is used to minimize thermal distortion in the output amplifier to reduce jitter in the display readout.

The vertical output signal at pins 28 and 33 of U600 (OUT A and OUT B) is applied to the vertical deflection plates of the crt (diagram 8) via L628 and L633. The deflection plates form a distributed-deflection structure that is terminated by a hybrid resistor network. One element of the terminating network is an adjustment potentiometer used to match the network impedance to that of the crt.

BANDWIDTH LIMITING. Bandwidth limiting coils L644 and L619, along with capacitors built into U600, form a three-pole filter used to roll off high-frequency response of the Vertical Output amplifier above 20 MHz. To limit the vertical bandwidth, the BWL (bandwidth limit) input to U600 (pin 16) is pulled LO. It may be set LO either by the BWL control data bit from Auxiliary Control Register U140 (diagram 4) when the operator selects the Bandwidth Limit feature or automatically by the output of NAND-gate U975A in the Vertical Channel Switch circuitry (via CR616) when the readout is being displayed.

TRACE SEPARATION. The voltage applied to the TS (trace separation) input of U600 (pin 42) is used to offset the output levels to vertically shift the position of the trace on the crt. During normal sweep displays, TS1 + TS2 signal applied to the base of Q600 by the Display Sequencer (diagram 5) is HI, and the transistor is turned on. The TRACE SEP level at the junction of R642 and CR600 is shunted to ground, and no offsetting at the output signal will occur. For those displays in which trace separation should occur, the Display Sequencer switches the base of Q600 to ground level to turn off the transistor. The trace separation level set by front-panel TRACE SEP control R3190 (via MUX U2530 and sample-and-hold circuit U2630C and C2631) is applied to the TS input of U600, and a corresponding offset of the displayed trace will occur.

BEAM FIND. As an aid in locating off-screen or overscanned displays, the instrument is provided with a beam-finding feature. When the front-panel BEAM FIND button is pushed, the beam-find input pin (BF, pin 15) of U600 will be pulled HI. While BF is HI, the dynamic range of Vertical Output Amplifier U600 is reduced, and all deflected traces will be held to within the vertical limits of the crt graticule.

Also, the activation of the BEAM FIND switch is detected by the microprocessor during its normal Front-Panel Switch Scanning. When detected, the generates a User Request SRQ if option 10 is installed.

OUTPUT PROTECTION CIRCUIT. A current-limit circuit composed of transistors Q623 and Q624 protects the Vertical Output Amplifier from a short-circuited output or a bias-loss condition. Either of these fault conditions will cause excessive current to flow into pins 30 and 31 of U600. Current in FET Q624 is limited to the IDSS current, so the voltage at pins 24, 30 and 31 will drop. This decreases the forward bias on pass-transistor Q623 and lowers the voltage at pin 23 of U600 enough to provide some degree of protection for the device.

Horizontal Amplifier

The Horizontal Amplifier circuitry consists of a Horizontal Output Amplifier U800, a unity-gain buffer amplifier made up of the five transistors in U735, and associated components.

UNITY-GAIN BUFFER AMPLIFIER. The amplifier circuit composed of U735A, B, C, D, and E along with their associated components, form a unity-gain amplifier that buffers the ramp signal from A Sweep Generator U700 to the Horizontal Output Amplifier. Transistors U735C and D form a differential pair with the negative excursion of their emitters limited to -5 V (clamped by U735E). Negative feedback from the collector of U735C to its base is via emitter-followers U735A and B (in parallel) which drive the A Sweep input (pin 18, A+) of Horizontal Output Amplifier U800.

HORIZONTAL OUTPUT AMPLIFIER. Integrated circuit U800 provides the final amplification of the selected horizontal-deflection signal required to drive the crt. One of the single-ended input signals applied to the four input pins is converted to a differential-output signal at the output pins of the amplifier. The four deflection signals to U800 are: the A sweep (pin 18, A+), the B Sweep (pin 16, B+), the Readout Horizontal signal (pin 17, RO) and the Channel 1 signal (used for horizontal deflection of the X-Y displays) at pin 20, the X+ input pin. Signal selection is done by an internal channel switch and is controlled by the HSA (horizontal select A) and HSB (horizontal select B) signals from the Display Sequencer (see Table 3-4).

Switching between unmagnified (X1) gain and magnified (X10 gain) is also controlled by signals from the Display Sequencer. For normal horizontal deflection, the MAG signal on pin 14 of U800 is HI, and the gain of the output amplifier produces normal sweep deflection. Precise X1 deflection gain is set by adjusting X1 Gain pot R860.

Table 3-4
Horizontal Display Selection

Control Level		Selected Signal
$\overline{\text{HSA}}$	$\overline{\text{HSB}}$	
H	H	Readout (X)
H	L	B Sweep Ramp
L	H	A Sweep Ramp
L	L	X Input (from CH 1)

When the X10 MAG feature is selected, amplifier gain for the magnified sweeps is increased by a factor of 10. The $\overline{\text{MAG}}$ signal from the Display Sequencer goes LO when magnified sweep is to be displayed. This switches the amplifier gain and switches analog switch U860C from the X1 position to the X10 position. Amplifier gain in the magnified mode is adjusted by adding or subtracting a small bias current using X10 Gain control R850. Dc offsets in the amplifier and crt are compensated for, using Horiz Centering pot R801 to precisely center the display. An intensity-dependent position correction signal, used to hold the horizontal centering stable over a wide range of varying display intensities, is also added at this point by the Dynamic Centering circuitry.

Timing and linearity of the sweep is affected by the amplifier transient response; and Trans Resp pot R802, connected to pin 2, is adjusted during calibration for optimum accuracy of the high-speed sweeps.

As with the Vertical Output Amplifier, the Beam Find feature reduces the dynamic range of the Horizontal Output Amplifier. While the front-panel BEAM FIND button is pressed in, a HI is placed on U800 pin 15 via pull-up resistor R615, and the horizontal deflection is reduced, moving horizontally off-screen displays to within the graticule viewing area.

Z-Axis Amplifier

Z-Axis Amplifier U950 turns the crt beam off and on at the desired intensity levels as the oscilloscope goes through its display sequence. The BRIGHT (brightness) signal applied to U950 pin 44 from the Display Sequencer U650 (diagram 5) is amplified to the level required to drive the crt control grid (via the DC Restorer circuitry) and sets the crt beam intensity. The BLANK input signal applied to U950 pin 5, also from the Display Sequencer, blanks the trace during sweep retrace, chop switching, and readout blanking by reducing the VZ OUT signal to a blanked level.

Sweep gate z-axis signals ($\overline{\text{SGAZ}}$ and $\overline{\text{SGBZ}}$) from the A Sweep and B Sweep hybrids (U700 and U900) respectively, (diagram 5) are applied to the Z-Axis Amplifier on pins 4 and 3. These signals turn the beam current on and off for the related displays and, when used in conjunction with the BLANK signal on pin 5, enable the sweeps to be blanked while still allowing the Readout circuitry to blank and unblank the crt for the readout displays.

Control signals applied to U950 pin 48, pin 2, and pin 1 ($\overline{\text{HSA}}$, $\overline{\text{HSB}}$, and TXY respectively) switch some internal logic circuitry to enable or disable different input signals for the various types of displays. Table 3-5 illustrates the effects of the various input signals on the output signal for different combinations of $\overline{\text{HSA}}$, $\overline{\text{HSB}}$, and TXY.

The Z-Axis hybrid has an internal limiter circuit that prevents the crt from being damaged during high-intensity, high-repetition-rate displays. A signal representative of the intensity setting and the sweep repetition rate is integrated on C957 and results in a control level at pin 7 of U950 used to limit intensity of the crt beam. Maximum Grid drive is controlled by R949 on U950 pin 9.

Focus tracking for intensity (VZ OUT) level changes is provided by the VQ OUT (quadrapole output voltage) signal at pin 22 of U950. The VQ OUT signal varies the focusing voltages (and thus the focusing strength) of two quadrapole lenses in the crt (diagram 8). The VQ OUT signal is related to the VQ OUT level exponentially and provides the greatest auto-focus control at high intensity levels. Gain of the VQ OUT signal is set by the High-Drive Focus adjustment, R1842. The VQ OUT signal also drives the Dynamic Centering circuit and holds the display position stable during wide-range intensity level changes.

Dynamic Centering

The circuit composed of U3401, U3402, and associated components generates compensating signals to offset positioning effects that occur in the crt when the intensity is varied over a wide range. The VQ OUT signal from Z-Axis Amplifier U950 is exponentially proportional to the display intensity and dynamically controls the intensity-dependent offsets.

Dynamic Centering adjustment pots R3401 and R3407 set the gain and polarity of the signals at their related outputs by varying the current in the emitter circuit of one of two emitter-coupled pairs of transistors. Adjusting the bias level, at either pin 4, above ≈ -10.6 volts (determined by R3410 and R3411 at the complementary inputs, pins 1) will generate an inverted signal, while adjusting the

Table 3-5
Blanking and Intensity Control Selection

Control Inputs			Intensity Affected By	Blanking Affected By	Typical Display
TXY	$\overline{\text{HSA}}$	$\overline{\text{HSB}}$			
X ^a	H	H	BRIGHT (RO level)	BLANK	Readout
X	H	L	BRIGHT, Z EXT	BLANK, $\overline{\text{SGAZ}}$, $\overline{\text{SGBZ}}$	Delayed Sweep
X	L	H	BRIGHT, $\overline{\text{SGBZ}}$, Z EXT	BLANK, $\overline{\text{SGAZ}}$	Main Sweep
L	L	L	BRIGHT, $\overline{\text{SGBZ}}$, Z EXT	BLANK	X-Y
H	L	L	BRIGHT, $\overline{\text{SGBZ}}$, Z EXT	BLANK, $\overline{\text{SGAZ}}$	X-Y

^aX = State doesn't matter.

bias levels below -10.6 volts will cause a noninverted signal. Amplitude of the resulting signal is dependent on how far from the -10.6-volt reference the bias is set. The output signal is added or subtracted from the position voltage applied to the Vertical and Horizontal Output Amplifiers. Both pots are adjusted so that position shifts due to display intensity variations are minimized.

READOUT

The Readout circuitry (diagram 7) is responsible for displaying the alphanumeric readout characters on the crt. An eight-bit character code specifying each character (or cursor segment) to be displayed is written from the Microprocessor to a corresponding location in the Character RAM U2920 (a 2K-x-8-bit, random-access memory integrated circuit). Each of the lower 64 locations in the RAM corresponds to one of the 64 possible character locations in the crt readout display (see Figure 3-6); 32 locations in the upper graticule row and 32 in the lower graticule row. The upper 64 RAM locations are used to store cursor segment information for the display of the ΔV and Δt measurement cursors. The eight-bit character code written to each location in RAM points to a block of addresses in Character ROM U2930. This block in the ROM contains the dot-position information for the specific character to be displayed at the associated crt position.

Each character is made up of zero (for a space character) or more dots displayed in an eight-wide by sixteen-high dot matrix. Specific blocks of ROM addresses contain all the X-Y offset coordinates for the dots in a particular character in the readout. The coordinates are referenced to the lower-left corner of the character dot matrix. Each individual data byte in the block of ROM addresses contains both the X and the Y coordinates for one dot of the associated character.

To display a character, a combination of the character position on the crt (the RAM address) and the byte of X-Y position data from Character ROM U2930 (relative to that character position) is applied to Horizontal and Vertical DAC (digital-to-analog converters) circuits, U2910 and U2905 respectively. In these circuits, the X-Y position data is converted to analog deflection signals used to position each dot in the crt readout display. Each of the position bytes are read from the block of ROM defining the character under control of the readout timing and sequencing circuitry. The resulting dots, when displayed in sequence, form the character at the proper location on the crt.

Readout I/O

The Readout I/O circuitry, composed of U2860, U2865, U2960, and associated components, provides the interface between the Microprocessor and the Readout board. Two types of data, Readout mode data and character data, are written to the Readout board serially via data bus line BD0.

STORING A CHARACTER. Displaying a character starts with serially clocking 15 of the 16 character data bits into a 16-bit shift register formed by registers U2960 and U2860. The $\overline{\text{ROS1}}$ strobe (readout strobe one) from the Address Decode circuitry (diagram 1) is the clocking signal. The first eight bits of the loaded data indicate the character to be displayed, while the last seven bits select the location on the crt that the character is to be displayed.

On positive-going transitions of the $\overline{\text{ROS1}}$ strobe, the data bit present on the BD0 data line is shifted into the first latch of character address register U2960. The following negative-going edges of the $\overline{\text{ROS1}}$ strobe are inverted

by U2965A to produce a positive transition that shifts the data bit present at U2960 pin 9 (Q_{SH}) into U2860. After 15 $\overline{ROS1}$ strobes have occurred, seven bits of character data are latched into U2860, and the eighth character bit and seven of the character address bits are latched into character address register U2960 (though they have not been shifted into their correct positions for addressing the RAM).

At this point, the last character bit remains to be shifted into the registers, but the operating mode must be set up first to ensure correct operation upon shifting in the final bit. The eight bits of mode data are shifted into the mode control register U2865 by the $\overline{ROS2}$ strobe. Bit Q_4 (WRITE), along with the $\overline{ROS2}$ and the R/W DLYD sig-

nal are applied to the RAM enabling circuitry and determine when new character information will be written into the Character RAM. With U2865 loaded with the mode data, a final $\overline{ROS1}$ strobe clocks the eighth bit of character data from U2960 to U2860 on the negative edge, and the positive edge of the strobe clocks the eighth character address bit (unused bit) into U2960.

With control bit Q_4 from U2865 LO, the outputs of U2860 are enabled and the eight bits of character data (CD0 through CD7) are written in parallel into the Character RAM at the location selected by the seven-bit address from U2960. Register U2960 is enabled only when the Readout is not displaying characters (the REST signal at pin 15 of U2960 is HI).

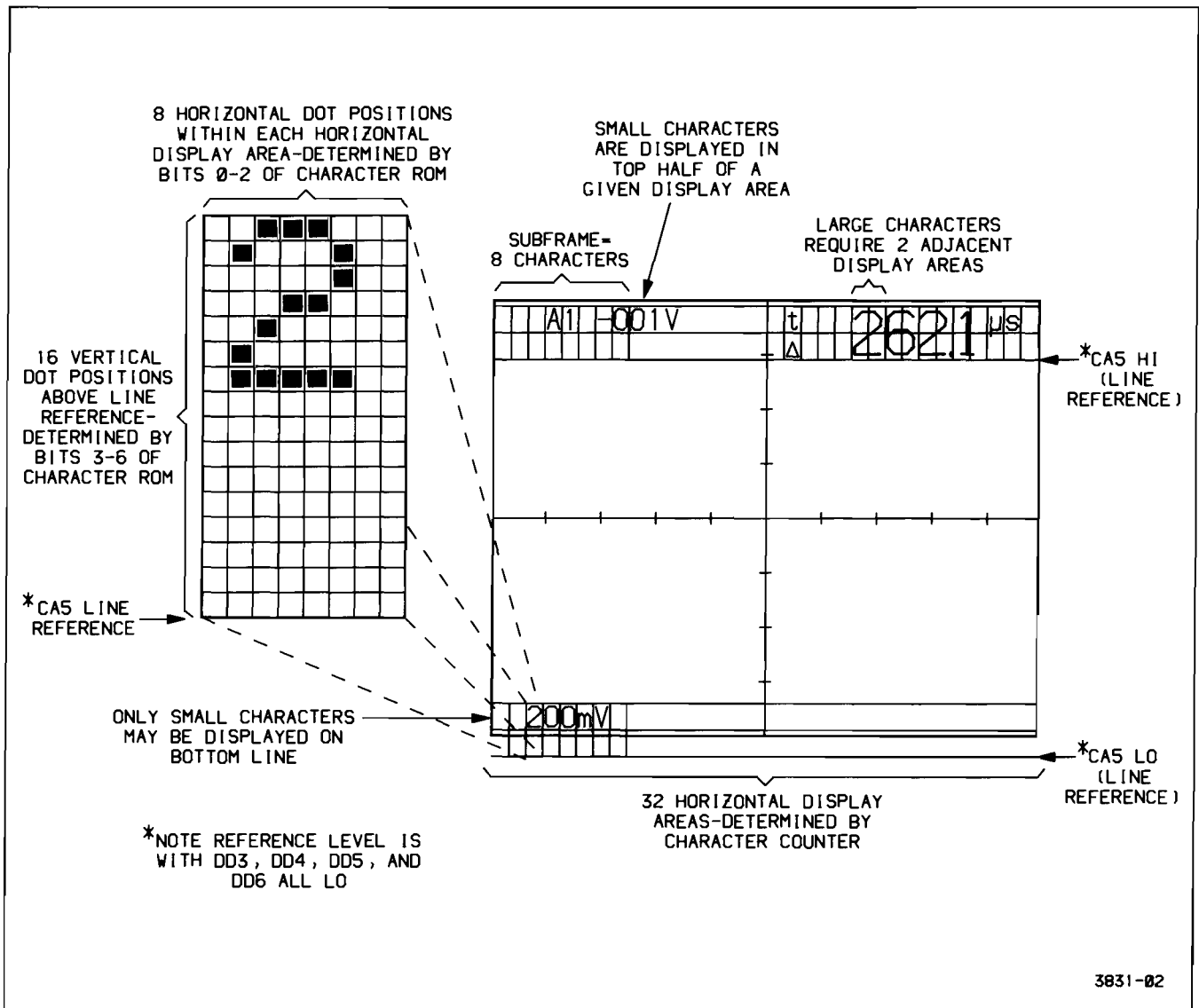

Figure 3-6. Developing the readout display.

Theory of Operation—2445A/2455A Service

The character data register U2860 also provides a means for the Microprocessor to read data from the Character RAM for partial verification of Readout circuit operation (during the power-up tests). The eight bits of parallel data from the Character RAM location selected by character address register U2960 are loaded into U2860 by setting bit Q_3 of mode control register U2865 LO. Inverter U2965C converts the LO to a HI and applies it to character-register U2860 at pin 1. The HI on pin 1, in combination with the fixed HI on pin 19 of U2860, switches the character register to the Parallel Load mode. The next positive transition of the $\overline{ROS1}$ strobe loads the eight data bits placed on the CD0 through CD7 bus lines into the register in parallel. Bit Q_3 is then returned HI, and the next positive transition of the $\overline{ROS1}$ strobe shifts the Q_A bit to pin 8 (Q_A'), the RO DO (readout data out) line. Seven more $\overline{ROS1}$ strobes shift the remaining seven bits of character data out onto the RO DO line to Status Buffer U2220 (diagram 2) to be read, one at a time, by the processor.

Character RAM

Character RAM U2920 provides temporary storage of the readout character selection data. This character data is organized as 128 eight-bit words that define the character that should be displayed at any given readout position on the crt. Cursor information is also stored in U2920 when cursors are to be displayed.

RAM locations may be addressed either from the Readout I/O stage by character address register U2960, as previously described, or by the Character Counter stage. The lower 64 address locations in RAM each correspond to a specific readout location on the crt, while the upper 64 address locations store cursor information. The eight bits of data written to one of these locations from the Readout I/O stage is a code that identifies the specific character (or cursor segment) that should be displayed at the associated crt location. After the display data is written into the RAM, the Character Counter is allowed to address the RAM, incrementing through the RAM address field. The eight-bit character codes for each display location are output to Character ROM U2930 in sequence.

Character Counter

The Character Counter stage consists of two four-bit counters (both within U2940) cascaded together to form an eight-bit counter (only seven of which are used) and tri-state buffer U2935 which drives the RAM address lines.

As the Character Counter addresses each RAM location (the counter also determines the character screen location), a sequence of "dot display cycles" is performed in which the individual dots that make up the character are

positioned on the crt and turned on. The \overline{EOCH} (end of character) signal applied to U2855A prevents the counter from incrementing until all dots of the character have been displayed. As the last dot of a character is addressed, the \overline{EOCH} bit at pin 2 of U2855A goes LO. The next \overline{GETDOT} pulse increments U2940 (via U2855A), and the next RAM location is addressed to start the display of the next character. Space characters have the \overline{EOCH} bit set LO for the first "dot" of the character and merely advance the Counter to the next character address without displaying any dots. See the Character ROM description for further explanation of the \overline{EOCH} bit.

Character ROM

Character ROM U2930 contains the horizontal and vertical dot-position information for all of the possible characters (or cursor segments) that may be displayed. The eight bits of character data from the Character RAM are applied to the eight most-significant address inputs (A4 through A11) of the Character ROM and select a block of dot-positioning data unique to the character to be displayed. The Dot Counter increments the four least-significant address lines (A0 through A3), causing the ROM to output a sequence of eight-bit words, each defining a dot position for the selected character.

The three least-significant bits of a ROM dot-data word (DD0 through DD2) select one of eight horizontal positions for the dot within an eight-by-sixteen character matrix (see Figure 3-6). The next four bits (DD3 through DD6) define the vertical position of the dot within the matrix. These dot-data bits are applied to the Horizontal and Vertical Character DACs, where they are converted to the analog voltages used to position the dot on the crt.

The last dot-data bit DD7 is the \overline{EOCH} (end of character) bit and, when LO, indicates that the last dot of the character is addressed. It is used to reset the Dot Counter (via U2855B) and enables the Character Counter to be incremented (via U2855A) after the last dot of a character has been displayed.

Two servicing jumpers, J401 and J402, have been provided to disable the Character ROM and force the DD7 bit (\overline{EOCH}) LO. In certain instances, these two conditions may be useful when troubleshooting the Readout circuitry. To prevent damage to the ROM output circuitry, J402 should only be installed after J401 is installed (to disable the ROM).

Dot Counter

The Dot Counter consists of two four-bit counters (both within U2870), OR-gate U2835A, inverter U2980D, and inverting input AND-gate U2855B. It sequences through a

block of addresses containing dot-position data for a selected character. The Dot Counter is incremented when a dot is finished (via Inverter U2980D) by the $\overline{\text{GETDOT}}$ signal from the Dot Cycle Generator.

The counter increments through the block of dot-position data until the last byte of the block is encountered (last dot). This last data byte has the $\overline{\text{EOCH}}$ (end of character) bit (DD7) set LO. The dot is positioned and displayed in the normal manner, but when the $\overline{\text{GETDOT}}$ signal occurs for the next dot display cycle, the $\overline{\text{EOCH}}$ bit is latched into U2905 and generates the $\overline{\text{EOCH1}}$ (end of character, delayed one dot) signal at U2905 pin 19. With $\overline{\text{EOCH}}$ and $\overline{\text{EOCH1}}$ both LO, the HI reset pulse produced at pin 4 of NOR-gate U2855B resets the counter and, except for space characters, the $\overline{\text{EOCH}}$ bit returns HI. As the reset is removed from the Dot Counter, it is reenabled for display of the next character. For space characters, the $\overline{\text{EOCH}}$ bit will be detected as a LO when the first dot is read from the Character ROM, and the Character Counter will advance to the next character on the next rising edge of $\overline{\text{GETDOT}}$.

Counter U2870 and OR-gate U2835A enable characters of more than 16 dots to be displayed. Since most of the readout characters are small, using 16 dots or less, efficient data storage is achieved by storing the dot-position data as 16 consecutive bytes. For displaying these smaller characters, the least significant four bits from U2870 are sufficient to address the 16 possible dot-position bytes.

When larger characters (up to 32 dots) are to be displayed, an additional bit of counter data must be used to address the ROM. This fifth bit comes from U2870 pin 3 and is ORed by U2835A with bit CD0 from the Character RAM. The block address for these larger characters always has bit CD0 set LO, so the counter bit from U2870 pin 3 is in control of the ROM address line at pin 4 of U2930. When displaying these larger characters, the dot count goes beyond 16 dots before the $\overline{\text{EOCH}}$ bit is set LO. On the seventeenth character, the fifth counter bit (pin 3 of U2870) will go HI to address the next 16-byte block of character data in ROM U2930. The lower four bits of the DOT Counter then sequence through this additional block in the normal manner until the $\overline{\text{EOCH}}$ bit is encountered, resetting the counter.

Horizontal DAC

The Horizontal DAC generates the voltages used to horizontally position dots of the readout display on the crt. Five data bits (CA0 through CA4) from the Character Counter stage position a character to the correct column in the display (32 possible columns across the crt), while three data bits from Character ROM U2930 (DD0 through DD2) horizontally position the dots within the eight-by-

sixteen character matrix (see Figure 3-6).

The eight bits of position data are written to the permanently enabled DAC each time a new dot is requested by the Dot Cycle Generator. The $\overline{\text{GETDOT}}$ signal applied to pin 11 (Chip Select) enables the DAC to be written into, and the falling edge of the 5-MHz clock applied to pin 12 (Write) writes the data at the eight DAC input pins into an internal latch. The voltage at the DAC output pin changes to reflect the data present in the latch.

Vertical Character DAC

The function of Vertical Character DAC U2905 is similar to that of the Horizontal DAC just described. It is responsible for vertically positioning each character dot on the crt. The Vertical DAC circuit is made up of five, D-type flip-flops (contained within U2905) and an accompanying resistor weighting network. The outputs of the flip-flops source different amounts of current to a summing node through a resistor weighting network.

The five data bits are latched into U2905 on the rising edge of the $\overline{\text{GETDOT}}$ signal. One bit of character address data (CA5) from the Character Counter switches the vertical display position between the upper and lower readout display lines. When the display is to be in the bottom line, bit CA5 is set LO. With CA5 LO, zener diode VR2925 is biased off and a small current is sourced to the summing node via R2925. Vertical position above this reference is determined by dot data bits DD3 through DD6. When the top line is to be displayed, the CA5 bit is set HI, biasing VR2925 on. A larger current is now sourced into the summing node via R2925 and enough voltage is developed across R2926 to move the display to the top row of the crt. As before, the individual dots are then positioned above this reference level by dot data bits DD3 through DD6.

Mode Select Logic and Analog Channel Switch

The Mode Select Logic circuitry is composed of analog switches U2800 and U2805, buffers U2820A and B, gates U2810A, B, C, and D, U2900B and C, and part of U2905. It controls the readout display mode by selecting which deflection signals should drive the Horizontal and Vertical Deflection Amplifiers during a readout display. Five display modes are decoded by the Mode Select Logic: character display, vertical cursor 0, vertical cursor 1, horizontal cursor 0, and horizontal cursor 1.

For normal character displays, cursor select bit CA6 on U2800 pin 1 is LO. This LO signal passes through analog switch U2800 and is latched into U2905 when the $\overline{\text{GETDOT}}$ request from the Dot Cycle Generator goes HI. This latched LO selects the character display mode by

**Table 3-6
Readout Display Mode Selection**

Control Bits				Mode Selected	Horizontal Signal	Vertical Signal
CA6 (Cursor Select)	DD5	DD4	DD3			
L	X ^a	X	X	Character Display	Horiz DAC	Vert DAC
H	L	H	L	Vert Cursor 1	Horiz DAC	DLY REF 1
H	L	H	H	Horiz Cursor 1	DLY REF 1	Horiz DAC
H	H	L	L	Vert Cursor 0	Horiz DAC	CURSOR 0
H	H	L	H	Horiz Cursor 0	CURSOR 0	Horiz DAC
H	L	L	X	Return to character display Mode		

^aX = State doesn't matter.

forcing the outputs of U2900B and C and U2810A and B HI. The HI outputs of U2900B and C applied to the select input pins of analog switch U2805 cause the Horizontal DAC output signal applied to U2805 pin 11 to be routed to the Horizontal Amplifier (diagram 6) via buffer U2820B. The same HI logic levels cause NOR-gates U2810C and D to produce a LO at their outputs. This causes analog switch U2800 to route the Vertical DAC output signal applied to pin 12 to the Vertical Output Amplifier (also diagram 6) via buffer U2820A.

For cursor displays, cursor select bit CA6 goes HI. This HI is routed through analog switch U2800 and latched into U2905 when GETDOT next goes HI. This produces a HI at U2905 pin 5, enabling the Mode Select Logic to decode output bits DD3, DD4, and DD5 (from U2905) to determine which of the four possible cursor modes is selected (see Table 3-6). Once one of the cursor modes is entered, analog switch U2800 routes a fixed HI from pin 5, pin 2, or pin 4 to U2905 to keep the Mode Select Logic enabled. Character display mode is reentered only when return-to-character-mode data is decoded (DD4 and DD5 both LO). When that occurs, U2800 routes the CA6 bit to U2905 and, if the bit is LO, the cursor display mode is halted.

CURSOR DEVELOPMENT. Cursors are displayed in short sections, alternating between both vertical positions (for the delta voltage cursors) or both horizontal positions (for the delta time cursors). When displaying delta voltage cursors, the CURSOR 0 level is routed to the Vertical Amplifier by analog switch U2800. This level determines the vertical position of one of the voltage cursors. Horizontal-positioning voltages for one segment of the cursor are routed from Horizontal DAC through analog

switch U2805 and buffer U2820B to horizontally position each of the dots making up the cursor segment. DLY REF 1 is then used to vertically position the second cursor, and the Horizontal DAC positions each of the dots for that cursor segment. The cycle is repeated until all segments of both cursors are displayed.

Delta time cursor displays are similar in that the CURSOR 0 and DLY REF 1 signals are used to position the cursors. In this case, however, analog switch U2805 selects the CURSOR 0 and DLY REF 1 signals alternately to position the cursors horizontally, and the Horizontal DAC output is routed via analog switch U2800 and buffer U2820A to vertically position the dots within each cursor segment.

Refresh Prioritizer

The Refresh Prioritizer circuitry consists of U2850A and B, U2950A, U2990A, and U2985. It keeps track of how well the Readout circuitry is doing in displaying all the required readout information and maintains the overall refresh rate. Since the readout display must remain flicker-free and at a constant intensity over the entire sweep rate range, various modes of displaying readout information are provided. The Refresh Prioritizer keeps track of the display status and enables the various readout-display modes as required to produce minimal interference with the displayed waveform trace(s).

Ideally, readout information should be displayed only when the oscilloscope is not trying to display waveform traces. These times occur before a trace commences, after a trace is completed, or between consecutive traces. Displaying in this mode corresponds to "priority one" in

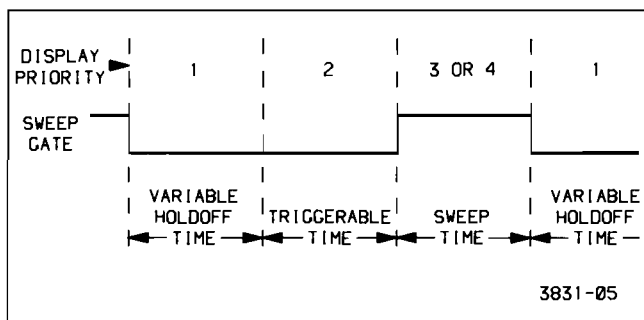

Figure 3-7. Readout display priorities.

Figure 3-7 and causes no interference with the displayed waveforms. If the Readout circuitry is able to display all the required readout dots during the holdoff time between sweeps, the prioritizer U2985 will turn off the Dot Start Governor until the next subframe of readout information is to be displayed. When the sweep times are either too fast to finish a readout display during holdoff (at 5 ns per division no identifiable holdoff time exists) or too slow to allow flicker-free readout, readout display modes other than priority one are initiated.

The next most desirable time for dots to be displayed is during "triggerable" time: that time between sweeps when the oscilloscope is waiting for a sweep trigger event to occur. This is designated priority two and may cause slight interference on the leading edge of the displayed trace if a dot is being displayed when the actual trigger occurs.

Finally, the least desirable dot display time is during a waveform trace display. This display time is designated either priority three or priority four. (Priority four indicates a higher demand of display time.) In priorities three and four, dot displays occur during the main portion of the waveform display. However, the waveform blanking associated with these displays is relatively random in nature and is usually not noticeable.

To start a readout display, the ROSFRAME (readout subframe) request from the Timing Logic (diagram 1) clocks the Q output of flip-flop U2850A HI. ROSFRAME is a periodic clocking signal used to hold the overall refresh rate constant and occurs at regular intervals, regardless of the state of the display.

As the Dot Cycle Generator runs, it resets half of U2830 in the Dot Timer at somewhat irregular intervals with the STARTDOT signal (via inverter U2890A). The Dot Timer then starts a timing sequence, and the rising edge of the REFRESH signal from U2830 pin 4 clocks the latched ROSFRAME request from U2850A pin 5 to the Q output (pin 9) of flip-flop U2850B. This HI, applied to the

S1 input (pin 10) of prioritizer U2985, sets it up to increment with the next REFRESH clock applied to its clock input (pin 11). The LO \bar{Q} output of U2850B (pin 8) applied to the reset input of U2850A resets the latched ROSFRAME request. See Figure 3-8 for an illustration of the timing sequence involved.

The next REFRESH clock increments the display priority to one by clocking a HI to the Q_D output (pin 12) of prioritizer shift register U2985. (Table 3-7 illustrates the operation of U2985.) The same clock latches the now LO ROSFRAME request at U2850B pin 12 to the Q output (pin 9), where it is applied to the S1 input (pin 10) of prioritizer U2985. The LO on the S1 input of the prioritizer will remain until another ROSFRAME request from the Timing Logic occurs, and the encoded priority at the output pins of U2985 will remain as it is presently set.

As each of the consecutive dots of the readout frame are displayed, the Dot and Character Counters increment until all dots of the subframe have been displayed (eight characters). As the Character Counter increments to address the next character of the display (first character of the next frame), the fourth bit of counter U2940 goes HI and sets the S0 input (pin 9) of prioritizer U2985 HI via exclusive-OR-gate U2990A. The Dot Timer then clocks the prioritizer with a REFRESH clock on pin 11 of U2985, and the priority is decremented back to zero (indicating that the subframe is completed). The next ROSFRAME request starts the process over again to display the next subframe of readout display. The sequence just described is the priority one display mode and is used when holdoff time between sweeps allows all dots of the subframe to be displayed before the next ROSFRAME request occurs.

If a second ROSFRAME request occurs before the Character Counter indicates the end of the subframe (to decrement the prioritizer back to zero), input S1 of U2985 will be set HI (while the S0 input pin remains LO) and the

Table 3-7
Operation of Prioritizer Shift Register

Select Inputs		Mode
S0	S1	
H	H	Parallel Load
H	L	L → Q_A (decrease priority)
L	H	H → Q_D (increase priority)
L	L	Hold Data

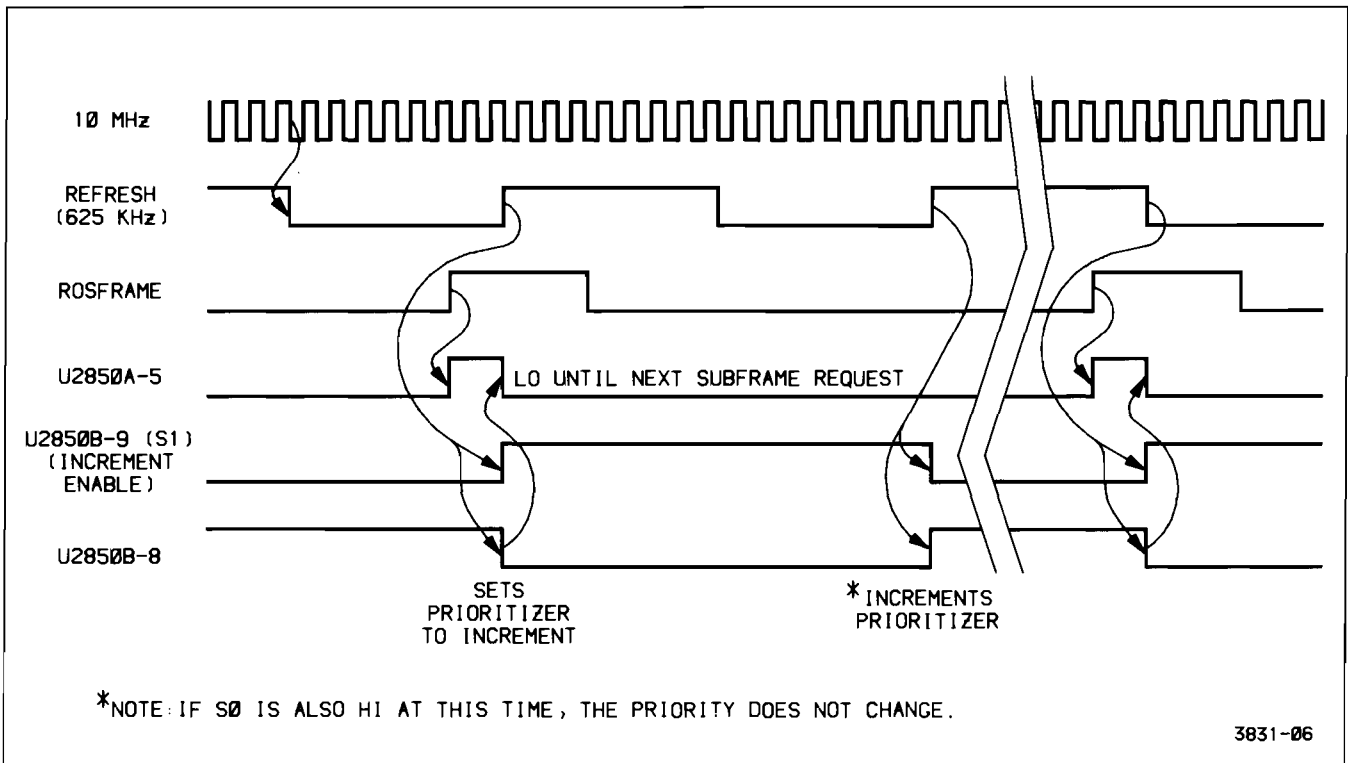

Figure 3-8. Timing of Refresh Prioritizer.

Prioritizer will increment to priority two (outputs Q_C and Q_D go HI) on the next STARTDOT cycle. If this display priority still is inadequate to complete the subframe display before the next ROSFRAME request occurs, priority two will be incremented up to priority three, or even to priority four should the condition persist. Priority four is operationally the same as priority three, but it is used to keep the readout circuitry continuously displaying readout data on through the next subframe, thus allowing the display to catch up. If priority four is in effect, the next decrement that occurs at the end of a subframe only returns the prioritizer to priority three, not to priority two.

The circuit composed of flip-flop U2950A and exclusive-OR-gate U2990A enables either edge of the CA3 bit to decrement the priority of the display when a subframe is completed. Either a negative or positive transition on pin 2 of U2990A will cause the output at pin 3 go HI since the Q output of U2950A is still at the opposite level. The HI from U2990A indicates that the end of the present subframe has occurred, and it sets up the prioritizer to decrement with the next REFRESH clock. At the same time that the prioritizer decrements, the changed level of the CA3 bit is clocked through U2950A and causes the output of exclusive-OR-gate U2990A to return LO until the next subframe is completed.

If the subframe is completed (S0 on U2985 goes HI) when a ROSFRAME request is also pending (S1 is also

HI), U2985 does a parallel load, reloading the present priority back into the prioritizer. Since, in this case, the subframe display was completed at the same rate as the ROSFRAME request occurred, the readout display priority is not changed.

Dot Start Governor

The Dot Start Governor detects the display priority from the Refresh Prioritizer and initiates dot-display cycles as the appropriate conditions are met. The conditions tested include display priority, sweep gate completion, dot completion, readout control status, and the readout active enable from the Display Sequencer.

When the readout board status line (ACTIVE/ADDRESSABLE) is HI (signifying display) and the REST line goes HI to indicate that the dot cycle is complete, AND-gate U2970C generates a HI at pin 8 (DOTOK) to signal that a new dot display is allowed. The HI from U2970C enables most of the gating in the Dot Start Governor. If the Refresh Prioritizer has encoded a display priority of either one or two, the output of exclusive-OR-gate U2990B is HI. When DOTOK from U2970C goes HI to enable a dot display, the LO reset from pin 6 of U2970B to pin 1 of flip-flop U2880A is removed. Now, when the A Sweep gate (SGA) goes HI (beginning of Holdoff), the HI at the D input of U2880A is clocked to the Q output and the \bar{Q} output at pin 6 will go LO, requesting display of a

priority one or two dot. This LO dot request is propagated through U2885B, U2890D, U2890B, and U2890C and sets the STARTDOT signal LO. STARTDOT going LO resets Dot Cycle Generator shift register U2995 and counter U2830B of the Dot Timer. Resetting the Dot Cycle Generator shift register causes the REST signal from U2995 pin 13 to go to a LO, removing the HI DOTOK signal at U2970C pin 8. As DOTOK goes LO, STARTDOT at pin 8 of U2890C goes HI to start the DOT Cycle Generator. At the same time the reset to U2880A is asserted via U2970B and the dot request is removed. Both the Dot Timer and the Dot Cycle Generator are now enabled and start the first dot-display cycle during holdoff time.

After the Display Sequencer U650 (diagram 5) has time to respond to the end of the sweep gate, it sets the readout active signal (\overline{ROA}) to pin 4 of U2880A LO. This sets pin 5 of U2855B LO, and the signal is propagated through U2855B, U2890D, U2890B, and U2890C, as before, resetting the Dot Timer and the Dot Cycle Generator. REST then goes LO as before and starts the Dot Cycle Generator and Dot Timer. This cycle continues, displaying one dot per cycle (except for the first non-displayed dot of a character which is automatically initiated by $\overline{EOCH2}$, until the Display Sequencer determines that the readout time is over (sets \overline{ROA} HI) or until the display priority is decremented to zero.

When a display priority of three or four exists, the output of U2990B will be LO, and U2970B, U2880A, and the associated logic gates following it will not be able to initiate a dot cycle. In either of these display priorities, U2970D, U2835C, U2980A, U2965B, and flip-flop U2950B detect the higher priority and generate a readout request signal (\overline{ROR}) to the Display Sequencer. The LO from U2950B pin 8 propagates through U2890B and U2890C to initiate a STARTDOT cycle. When the Display Sequencer recognizes that the readout request signal is LO, it will perform the mode-dependent setup functions necessary to give display control to the Readout Board and will then set the \overline{ROA} (readout active) line LO. The LO will be clocked into U2880B, and the Dot Cycle Generator will generate a \overline{GETDOT} signal, resetting the readout request from flip-flop U2950B. Only one dot is displayed for each readout request.

A similar readout display request will be generated when priority-two-or-higher displays are required when sweep gates are not present (dot display during triggerable time after holdoff). This condition is detected by NAND-gate U2885A. AND-gate U2970D allows a readout request to be generated when in the interfere mode. This mode is only invoked during a single-sequence waveform display and ensures that all of the selected sweep combinations are displayed once, followed by a complete readout frame (for the purpose of crt photography).

Dot Cycle Generator

The Dot Cycle Generator, composed of shift register U2995, flip-flop U2880B, and associated gating circuitry, generates time-related signals for the following purposes: unblinking the crt to display a dot; requesting the next byte of dot data in preparation for displaying the next dot; and reenabling itself to repeat the tasks, via the Dot Start Governor (dependent on the display priority).

The timing relationships of the Dot Cycle Generator output signals are controlled by shift register U2995. When the Dot Start Governor initiates a STARTDOT cycle as previously described, the STARTDOT signal initially goes LO, resetting all the Q outputs of U2995 LO and setting the Q output of flip-flop U2880B to a HI. The STARTDOT signal is then returned HI, and the Dot Timer counter U2830A and shift register U2995 are enabled. The shift register begins to consecutively shift HI logic levels to its Q output pins with each 5-MHz clock from the Dot Timer. After approximately 400 ns, pin 5 (Q_C) of the shift register will go HI. The HI at Q_C propagates through exclusive-OR-gate U2990D and AND-gate U2970A to unblank the crt by setting the readout blanking signal (\overline{ROB}) HI.

When the Q_F output of U2995 goes HI (1 μ s after STARTDOT), the output of U2990D goes LO and the output of U2990C goes HI. The LO from U2990D propagates through U2970A to blank the crt (\overline{ROB} goes LO) and to clock flip-flop U2880B via NAND-gate U2980C. The \overline{ROA} (readout active) level from the Display Sequencer (diagram 5) is clocked from the D input (pin 12) of U2880B to the Q output; and, if LO (indicating that the readout circuitry had control of the crt when unblinking occurred; thus the dot was displayed), the output of U2980B is set HI. With three HI levels applied to NAND-gate U2885C, a \overline{GETDOT} request is generated to get the next byte of dot-position data for display. The next 5-MHz clock sets the Q_G output of U2995 HI, and the output of U2990C goes LO, removing the LO \overline{GETDOT} signal.

At 1.4 μ s after STARTDOT goes HI, U2995 pin 13 (Q_H) goes HI to produce the REST signal, indicating that the current dot cycle is complete and the Dot Cycle Generator is at REST. If the readout ACTIVE/ ADDRESSABLE mode bit at U2970C pin 10 is still HI, the REST signal going HI produces a HI DOTOK signal (next dot is allowed) at pin 8. This HI applied to pin 10 of U2890C, along with any of the possible dot requests from the Dot Start Governor, will initiate another STARTDOT cycle for the next dot of the display. As long as the Display Sequencer holds the readout active line (\overline{ROA}) LO, U2885B, U2890D, and U2890B of the Dot Start Governor will automatically initiate dot cycles as soon as the previous one ends (REST goes HI), until the Refresh Prioritizer is decremented to zero.

When the last dot of the character is called from the Character ROM, the $\overline{\text{EOCH}}$ bit (DD7) applied to latch U2905 at pin 18 (in the Vertical Character DAC circuitry) is LO. At the end of that dot display cycle, the $\overline{\text{GETDOT}}$ signal (going HI) clocks the LO $\overline{\text{EOCH}}$ bit into latch U2905 and increments character counter U2940. The latched bit becomes the $\overline{\text{EOCH1}}$ signal (end of character, delayed one dot request) and is applied to U2885B, along with the already LO $\overline{\text{EOCH}}$ bit, to reset Dot Counter U2870. The least-significant bits to the Character ROM address pins (A0 through A4) are then zeros, and the first dot of the next character is addressed. The Horizontal and Vertical DACs don't write this first dot position data into their registers until the end of the next $\overline{\text{GETDOT}}$ signal. That same $\overline{\text{GETDOT}}$ signal also clocks $\overline{\text{EOCH1}}$ into U2905 which becomes $\overline{\text{EOCH2}}$ at pin 6 (end of character, delayed by two dot requests). $\overline{\text{EOCH2}}$ is applied to AND-gate U2970A and disables the gate prior to the time the Dot Cycle Generator attempts to unblank the crt for the first dot display; thus the first dot of a character is never displayed.

Disabling the unblanking path for the first dot of each character in the manner just described allows the more radical voltage changes between characters to settle before the actual display of the next character begins. When the dot data for one of these undisplayed dots also has the $\overline{\text{EOCH}}$ bit set LO, it is a space character, and the display is advanced to the next character.

Dot Timer

The Dot Timer, composed of U2890A and U2830, generates three, time-related signals used to synchronize the display and maintain the proper sequencing of the individual character dots.

The two least-significant bits of the Dot Timer, from U2830 pins 11 and 10, are reset at the beginning of a dot cycle by a LO STARTDOT signal applied to the reset input of the counter via U2890A. As the dot-display cycle begins, the STARTDOT signal returns HI and the Dot Timer begins counting in a binary fashion. The 10-MHz clock applied to pin 13 is divided by two to produce the 5-MHz clocking signal at output pin 11. The 5-MHz clock sequences the Dot Cycle Generator through the various phases of the dot-display cycle. The REFRESH output signal from U2830 pin 4 updates the Refresh Prioritizer as each subframe is displayed.

A third clock, from U2830 pin 6, occurs at approximately 8- μ s intervals and allows any pending dot requests to generate a $\overline{\text{ROR}}$ signal to the Display Sequencer via flip-flop U2950B. (Readout request generation is described in the Dot Start Governor discussion.)

HIGH VOLTAGE POWER SUPPLY AND CRT

The High-Voltage Supply and CRT circuit (diagram 8) provides the voltage levels and control circuitry for operation of the cathode-ray tube (crt). The circuitry consists of the High Voltage Oscillator, the High Voltage Regulator, the Cathode Supply, the Anode Multiplier, the DC Restorer, Focus Amplifiers, the CRT and the various CRT Control circuits.

High-Voltage Oscillator

The High-Voltage Oscillator transforms power obtained from the -15 volt unregulated supply to the various ac levels necessary for the operation of the crt circuitry. The circuit consists of transformer T1970, switching transistor Q1981, and associated circuitry. The low-voltage oscillations set up in the primary winding of T1970 are raised by transformer action to high-voltage levels in the secondary windings. These ac secondary voltages are applied to the DC Restorer, the Cathode Supply, and the anode multiplier circuits.

Oscillation occurs due to the positive feedback from the primary winding (pin 4 to pin 5) to the smaller base-drive winding (pin 3 to pin 6) for transistor Q1981. The frequency of oscillation is about 50 kHz, and is determined primarily by the resonant frequency of the transformer.

When power is first applied, the High-Voltage Regulator circuit detects that the negative crt cathode voltage is too positive and pulls pin 2 of transformer T1970 negative. The negative level forward biases transistor Q1981 via the base-drive winding of the transformer. Current begins to flow in the primary winding through transistor Q1981, inducing a magnetic field around the transformer primary winding. The increasing magnetic field induces a current in the base-drive winding that further increases the base drive to the transistor. This in-phase feedback causes current in Q1981 to increase until the primary winding current reaches its maximum value. As the rate of change of the primary current peaks and then reverses, the induced magnetic field begins to decay. This decreases the base-drive current and begins turning Q1981 off.

As Q1981 is beginning to turn off, the magnetic field around the primary winding continues to collapse at the resonant frequency rate of the transformer. This induces into the base-drive winding a voltage that completely turns off the transistor. The collapsing magnetic field goes to zero, then builds in the opposite direction to a maximum before collapsing again (resonant flywheel effect). This sequence of events occurs repetitively as the circuit continues to oscillate.

The oscillating magnetic field in the primary winding couples power into the secondary windings of the transformer. The amplitude of the voltages induced in the secondary windings is a function of the turns ratios of the transformer windings.

High-Voltage Regulator

The High-Voltage Regulator consists of U1956A and B and associated components. It monitors the crt Cathode Supply voltage and varies the bias point of the switching transistor in the High Voltage Oscillator to hold the Cathode Supply voltage at the nominal level. Since the output voltages at the other secondary winding taps are related by turns ratios to the Cathode Supply voltage, all voltages are held in regulation.

When the Cathode Supply voltage is at the proper level (-1900 V), the current through R1945 and the $19\text{-M}\Omega$ resistor internal to High Voltage Module U1830 holds the voltage developed across C1932 at zero volts. This is the balanced condition and sets base drive in Q1981 via integrator U1956A and voltage-follower U1956B. Varying base drive to Q1981 holds the secondary voltages in regulation.

If the Cathode Supply voltage level tends too positive, a slightly positive voltage will develop across C1932. This voltage causes the outputs of integrator U1956A and voltage-follower U1956B to move negative. The negative shift charges capacitor C1951 to a different level, around which the induced feedback voltage at the base-drive winding will swing. The added negative bias causes Q1981 to turn on earlier in the oscillation cycle, and a stronger current pulse is induced in the secondary windings. The increased power in the secondary windings increases the secondary voltages until the Cathode Supply voltage returns to the balanced condition (zero volts across C1932). Opposite action occurs should the Cathode Supply voltage tend too negative.

Cathode Supply

The Cathode Supply circuit is composed of a voltage-doubler and an RC filter network contained within High-Voltage Module U1830. This supply produces the -1900 V accelerating potential applied to the CRT cathode and the -900 V slot lens voltage. The -1900 V supply is monitored by the High Voltage Regulator to maintain the regulation of all voltages from the High Voltage Oscillator.

The alternating voltage (950 V peak) from pin 10 of transformer T1970 is applied to a conventional voltage-doubler circuit at pin 7 of the High Voltage Module. On the positive half cycle, the input capacitor of the voltage doubler ($0.006\ \mu\text{f}$) is charged to -950 V through the forward-

biased diode connected to ground at pin 9 of the module (charging path is through the diode, so stored charge is negative). The following negative half cycle adds its ac component (-950 V peak) to this stored dc value and produces a total peak voltage of -1900 V across the capacitor. This charges the $0.006\text{-}\mu\text{f}$ storage capacitor (connected across the two doubler diodes) through the second diode (now the forward-biased diode) to -1900 V. Two RC filters follow the voltage doubler to smooth out the ac ripple. A resistive voltage divider across the output of the filter network provides the -900-V slot lens potential.

Anode Multiplier

The Anode Multiplier circuit (also contained in High Voltage Module U1830) uses voltage multiplication to produce the $+14$ kV CRT anode potential. Circuit operation is similar to that of the voltage-doubler circuit of the Cathode Supply.

The first negative half-cycle charges the $0.001\text{-}\mu\text{f}$ input capacitor (connected to pin 8 of the High Voltage Module) to a positive peak value of $+2.33$ kV. The following positive half cycle adds its positive peak amplitude to the voltage stored on the input capacitor and boosts the charge on the second capacitor of the multiplier (and those following) to $+4.66$ kV. Following cycles continue to boost up succeeding capacitors to values 2.33 kV higher than the preceding capacitor until all six capacitors are fully charged. This places the output of the last capacitor in the multiplier at $+14$ kV above ground potential. Once the multiplier reaches operating potential, succeeding cycles replenish current drawn from the Anode Multiplier by the crt beam. The $1\text{-M}\Omega$ resistor in series with the output protects the multiplier by limiting the anode current to a safe value.

Focus Amplifier

The Focus Amplifier, in conjunction with the auto-focus circuitry of Z-Axis hybrid U950 (diagram 6), provides optimum focus of the crt beam for all settings of the front-panel INTENSITY control. The Focus Amplifier itself consists of two shunt-feedback amplifiers composed of Q1851, Q1852, and associated components. The outputs of the amplifiers set the operating points of a horizontally converging quadrapole lens and a vertically converging quadrapole lens within the crt. The convergence strength of each lens is dependent on the electric field set up between the lens elements.

Since the bases of Q1851 and Q1852 are held at constant voltages (set by their emitter potentials), changing the position of the wiper arms of the ASTIG and FOCUS pots changes the amount of current sourced to the base junctions through R1856 and R1857 respectively. This changes the base-drive currents and produces different

to the elevated crt control-grid potential (about -1.9 kV).

The DC Restorer circuit (Figure 3-9) operates by impressing the crt grid bias setting and the Z-Axis drive signal on an ac voltage waveform. The shaped ac waveform is then coupled to the crt control grid through a coupling capacitor that restores the dc components of the signal.

GRID BIAS LEVEL. An ac drive voltage of approximately 300 V peak-to-peak is applied to the DC Restorer circuit from pin 7 of transformer T1970. The negative half cycle of the sinusoidal waveform is clipped by CR1953, and the positive half cycle (150 V peak) is applied to the junction of CR1930, CR1950, and R1941 via R1950 and R1953. Transistor Q1980, operational amplifier U1890A, and associated components form a voltage clamp circuit that limits the positive swing of the ac waveform at the junction.

Transistor Q1980 is configured as a shunt-feedback amplifier, with C1991 and R1994 as the feedback elements. The feedback current through R1994 develops a voltage across the resistor that is positive with respect to the $+42.6$ V on the base of the transistor. The value of this additive voltage plus the diode drop across CR1950 sets the upper clamping threshold. Grid Bias potentiometer R1878 sinks varying amounts of current away from the base node of the transistor and thus sets the feedback current through R1994. The adjustment range of the pot can set the nominal clamping level between $+71$ V and $+133$ V.

When the amplitude of the ac waveform is below the clamping threshold, series diode CR1950 will be reverse biased and the ac waveform is not clamped. During the time the diode is reverse biased, transistor Q1980 is kept biased in the active region by the charge retained on C1971 from the previous cycle. As the amplitude of the ac waveform at the junction of CR1930 and CR1950 exceeds the voltage at the collector of Q1980, diode CR1950 becomes forward biased, and the ac waveform is clamped at that level. Any current greater than that required to maintain the clamp voltage will be shunted to the $+42$ V supply by transistor Q1980.

Operational amplifier U1890A sinks a time-dependent variable current away from the base node of Q1980 that modifies the crt control-grid bias during the first few minutes of instrument operation. The circuit compensates for the changing drive characteristics of the crt as it warms up.

At power-up, capacitor C1990 begins charging through R1991 toward the $+15$ V supply. The output of U1890A

follows the rising voltage on pin 3; and after about ten minutes (for all practical purposes), it reaches $+15$ V. As the output voltage slowly increases, the charging current through R1992 causes the Grid Bias voltage to gradually lower about ten volts from its power-on level. The charge on C1990 dissipates slowly; therefore, if instrument power is turned off and then immediately back on again, the output of U1890A will still be near the $+15$ V limit rather than starting at zero volts as when the crt was cold.

Z-AXIS DRIVE LEVEL. The variable-level Z-Axis signal (VZ OUT) establishes the lower clamping level of the ac waveform applied to the High Voltage Module. When the amplitude of the waveform drops below the Z-Axis signal, CR1930 becomes forward biased, and the ac waveform is clamped to the Z-Axis signal level. The VZ OUT level may vary between $+8$ V and $+75$ V, depending on the setting of the front-panel INTENSITY and READOUT INTENSITY controls.

The ac waveform, now carrying both the grid-bias information and the Z-Axis drive information, is applied to a DC Restorer circuit in the High Voltage Module where it is raised to the high-voltage levels of the crt control grid.

DC RESTORATION. The DC Restorer circuit in the High Voltage Module is referenced to the crt cathode voltage via a connection within U1830. Capacitor C (in Figure 3-9), connected to pin 15 of U1830, initially charges to a level determined by the difference between the Z-Axis signal level and the crt cathode potential. The Z-Axis signal sets the level on the positive plate of capacitor C through R1920, CR1930, and R1941; the level on the negative plate is set by the crt cathode voltage through resistor E and diode A. Capacitor D is charged to a similar dc level through resistors F, R1922, and R1913.

When the ac waveform applied to pin 15 begins its transition from the lower clamped level (set by the Z-Axis signal) towards the upper clamped level (set by the Grid Bias potentiometer), the charge on capacitor C increases. The additional charge is proportional to the voltage difference between the two clamped voltage levels.

When the ac waveform begins its transition from the upper clamped level back to the lower clamped level, diode A becomes reverse biased. Diode B becomes forward biased, and an additional charge proportional to the negative excursion of the ac waveform (difference between the upper clamped level and the lower clamped level) is added to capacitor D through diode B and resistor G. The amount of charge added to capacitor D depends on the setting of the front-panel INTENSITY control, as it sets the lower clamping level of the ac waveform. This added charge determines the potential of the control grid with respect to the crt cathode.

Theory of Operation—2445A/2455A Service

The potential difference between the control grid and the cathode controls the beam current and thus the display intensity. With no Z-Axis signal applied (INTENSITY control off), capacitor D will be charged to its maximum negative value, since the difference between the two clamped voltage levels is at its maximum value. This is the minimum intensity condition and reflects the setting of the Grid Bias potentiometer. During calibration, the Grid Bias pot is adjusted so that the difference between the upper clamping level (set by the Grid Bias pot) and the "no signal" level of the Z-Axis drive signal (VZ OUT) produces a control grid bias that barely shuts off the crt electron beam.

As the INTENSITY control is advanced, the amplitude of the square-wave Z-Axis signal increases accordingly. This increased signal amplitude decreases the difference between the upper and lower clamped levels of the ac waveform, and less charge is added to capacitor D. The decreased voltage across capacitor D decreases the potential difference between the control grid and the cathode, and more crt beam current is allowed to flow. Increased beam current increases the crt display intensity.

During the periods that capacitor C is charging and discharging, the control-grid voltage is held stable by the long-time-constant discharge path of capacitor D through resistor F. Any charge removed from capacitor D during the positive transitions of the ac waveform will be replaced on the negative transitions.

The fast-rise and fast-fall transitions of the Z-Axis signal are coupled to the crt control grid through capacitor D. This ac-coupled fast-path signal quickly sends the crt electron beam to the new intensity level, then the slower DC Restorer path "catches up" to handle the dc and low-frequency components of the Z-Axis drive signal.

Neon lamps DS90 and DS91 prevent arcing inside the crt should the control grid potential or cathode potential be lost for any reason.

CRT Control Circuits

The CRT Control circuits provide the various potentials and signal attenuation factors that set up the electrical elements of the crt. The control circuitry is divided into two separate categories: (1) level setting and (2) signal handling. The level setting circuitry produces voltages and current level necessary for the crt to operate, while the signal-handling portion is associated with changing crt signal levels.

LEVEL-SETTING CIRCUITRY. Operational amplifier U1890B, transistor Q1980, and associated components

form an edge-focus circuit that sets the voltages on the elements of the third quadrupole lens. The positive lens element is set to its operating potential by Edge Focus adjustment pot R1864 (via R1897). This voltage is also divided by R1893 and R1982 and applied to the non-inverting input of U1890B to control the voltage on the other element of the lens.

The operational amplifier and transistor are configured as a feedback amplifier, with R1891 and R1990 setting the stage gain. Gain of the amplifier is equal to the attenuation factor of divider network R1893 and R1892, so total overall gain of the stage from the wiper of R1864 to the collector of Q1890 is unity. The offset voltage between lens elements is set by the ratio of R1891 and R1990 and the +10 V reference applied to R1990. This configuration causes the two voltages applied to the third quadrupole lens to track each other over the entire range of Edge Focus adjustment pot R1864.

Other adjustable level-setting circuits include Y-Axis Alignment pot R1848, used to rotate the beam alignment after vertical deflection. This adjustment controls the amount of current through the Y-Axis Alignment coil around the neck of the crt and is set to produce precise perpendicular alignment between x- and y-axis deflections. The TRACE ROTATION adjustment R975 is a front-panel screwdriver-adjustable control. The effect of the adjustment is similar to the Y-Axis Alignment pot, but when adjusted, it rotates both the x-axis and the y-axis deflections of the trace on the face of the crt. A final adjustable level-setting control is the Geometry pot R1870, adjusted to optimize display geometry. The potential at pin 8 for the vertical shield internal to the crt is produced by zener diode VR1891 and associated components.

SIGNAL-HANDLING CIRCUITRY. The crt termination adjustment R1501 is set to match the loading characteristics of the crt's vertical deflection structure to the Vertical Output Amplifier.

LOW VOLTAGE POWER SUPPLY

The low voltages required by the instrument are produced by a high-efficiency, switching power supply. This type of supply directly rectifies and stores charge from the ac line supply; then the stored charge is switched through a special transformer at a high rate, generating the various supply voltages.

Line Rectifier

Ac line voltages of either 115 V or 230 V may provide the primary power for the instrument, depending on the setting of LINE VOLTAGE SELECTOR switch S90

(located on the instrument rear panel). Power Switch S350 applies the selected line voltage to power supply rectifier CR1011.

With the selector switch in the 115 V position, the rectifier and storage capacitors C1021 and C1022 operate as a full-wave voltage doubler. When operating in this configuration, each capacitor is charged on opposite half cycles of the ac input, and the voltages across the two capacitors in series will approximate the peak-to-peak value of the source voltage. For 230 V operation, switch S90 connects the rectifier as a conventional bridge rectifier. Both capacitors charge on both input half cycles, and the voltage across C1021 and C1022 in series will approximate the peak value of the rectified source voltage. For either configuration, the dc voltage supplied to the power supply inverter is the same.

Thermistors RT1010 and RT1016 limit the surge current when the power supply is first turned on. As current flow warms the thermistors, their resistances decrease and have little effect on circuit operation. Spark-gap electrodes E1001 and E1002 are surge-voltage protectors. If excessive source voltage is applied to the instrument, the spark-gaps conduct, and the extra current flow quickly exceeds the rating of fuse F90. The fuse then opens to protect the instrument's power supply. The EMI (electromagnetic interference) filter, inductors L1011 and L1012, capacitors C1016 and C1018, and resistors R1011, R1012, R1016 and R1018 form a line-filter circuit. This filter, along with common mode rejection transformer T1020, prevents power-line interference from entering the instrument and prevents power supply switching signals from entering the supply line.

Preregulator Control

The Preregulator Control circuit monitors the drive voltage applied to inverter output transformer T1060 and holds it at the level that produces proper supply voltages at the secondary windings.

The Preregulator Control circuit consists primarily of control IC U1030, its switching buffers, and its power supply components. The control IC senses voltage on the primary winding of T2060 and varies the "on time" of a series-switching transistor, depending on whether the sensed voltage was too high or too low. The switching transistor Q1050, rectifier CR1050, choke T1050, and capacitor C1050 form a buck-switching regulator circuit. The output voltage at W1060 is proportional to the product of the rectified line voltage on C1020-C1022 and the duty cycle of Q1050. In normal operation, Q1050 is on about one-half the time. When Q1050 is off, current flows to W1060 and T1060 through CR1050.

PREREGULATOR CONTROL POWER SUPPLY. Since the Preregulator Control network controls supply startup and preregulates the secondary supplies, an independent power source must be established for it before any of the other power supplies will operate. The independent power supply for the control circuitry is composed of Q1021, Q1022, and associated components.

Initially, when instrument power is applied, the positive plate of capacitor C1025 is charged toward the positive rectified line voltage through R1020. The voltage at the base of Q1022 follows at a level determined by the voltage divider composed of R1022, R1024, CR1023, and the load within U1030. When the voltage across C1025 reaches about +21 V, the base voltage of Q1022 reaches +6.8 V and Q1022 turns on, saturating Q1021. The +21 V on the emitter of Q1021 appears at its collector and establishes the positive voltage supply for the Preregulator IC. With Q1021 on, R1024 is placed in parallel with R1022, and both Q1022 and Q1021 remain saturated.

The +21 V level begins to drain down as the control IC draws current from C1025. If the Preregulator Control IC doesn't start the switching supply (and thus recharge C1025 and C1023 via CR1022) by the time the voltage across C1025 reaches about +8 V, Q1021 will turn off. Resistor R1024 pulls the base of Q1022 low and turns that transistor off also. (Capacitor C1025 would only discharge low enough to turn off the transistors under a fault condition.) In this event, C1025 would then charge again to +21 V, and the start sequence would repeat. Normally, the control IC will start Inverter action before the +8 V level is reached, and current is drawn through T1050 via Q1050. This induces a current in the secondary winding of T1050 via Q1050. This induces a current in the secondary winding of T1050 and charges C1025 positive via diode CR1022. The turns ratio of T1050 sets the secondary voltage at approximately +15 V; and, as long as the supply is being properly regulated, C1025 will be charged up to that level and held there.

PREREGULATOR START-UP. As the supply for the Preregulator Control IC is established, an internal switching oscillator begins to run. The oscillator generates a repetitive triangular wave (as shown in Figure 3-10) at a frequency determined primarily by R1032 and C1032. The simplified schematic of Figure 3-11 illustrates the voltage control functions of U1030.

As the Preregulator power supply turns on, capacitor C1034 charges from the +5 V reference level toward ground potential through R1034 and R1037. As it does, the voltage at pin 4 (one input of Dead-Time Comparator U1) will pass through the positive-peak value of the triangular waveform on the other input of the Dead-Time

Theory of Operation—2445A/2455A Service

Comparator. The comparator will then begin outputting narrow pulses that become progressively wider as the voltage on pin 4 settles to zero volts. These pulses drive switching transistor Q1050, and their slow progression from narrow to wide causes the various secondary supplies to gradually build up to their final operating levels. The slow buildup prevents a turn-on current surge that would cause the current-limit circuitry to shut down the supply.

During startup, capacitor C1072 acts as a substantial load, and a relatively large current flows in the windings of T1050 for the first few cycles of Preregulator switching. These strong current pulses ensure that storage capacitor C1066 becomes charged sufficiently to start the Inverter

Drive circuit. Once the Inverter Drive stage is operating, the normal switching current through T1050 maintains the required charge on C1066. (The Inverter Drive power supply is discussed later in this description.)

Dead-Time Comparator U1 is referenced at approximately 0.1 V above the ground level at pin 4 (established when C1034 becomes fully charged) and outputs a narrow, negative-going pulse that turns off switching transistor Q1050 for a portion of each switching cycle. This off time ensures that flip-flop U1064B in the Inverter Drive circuit toggles every cycle (thereby maintaining the proper duty cycle), independent of the voltage conditions being sensed by the remainder of the voltage control circuitry.

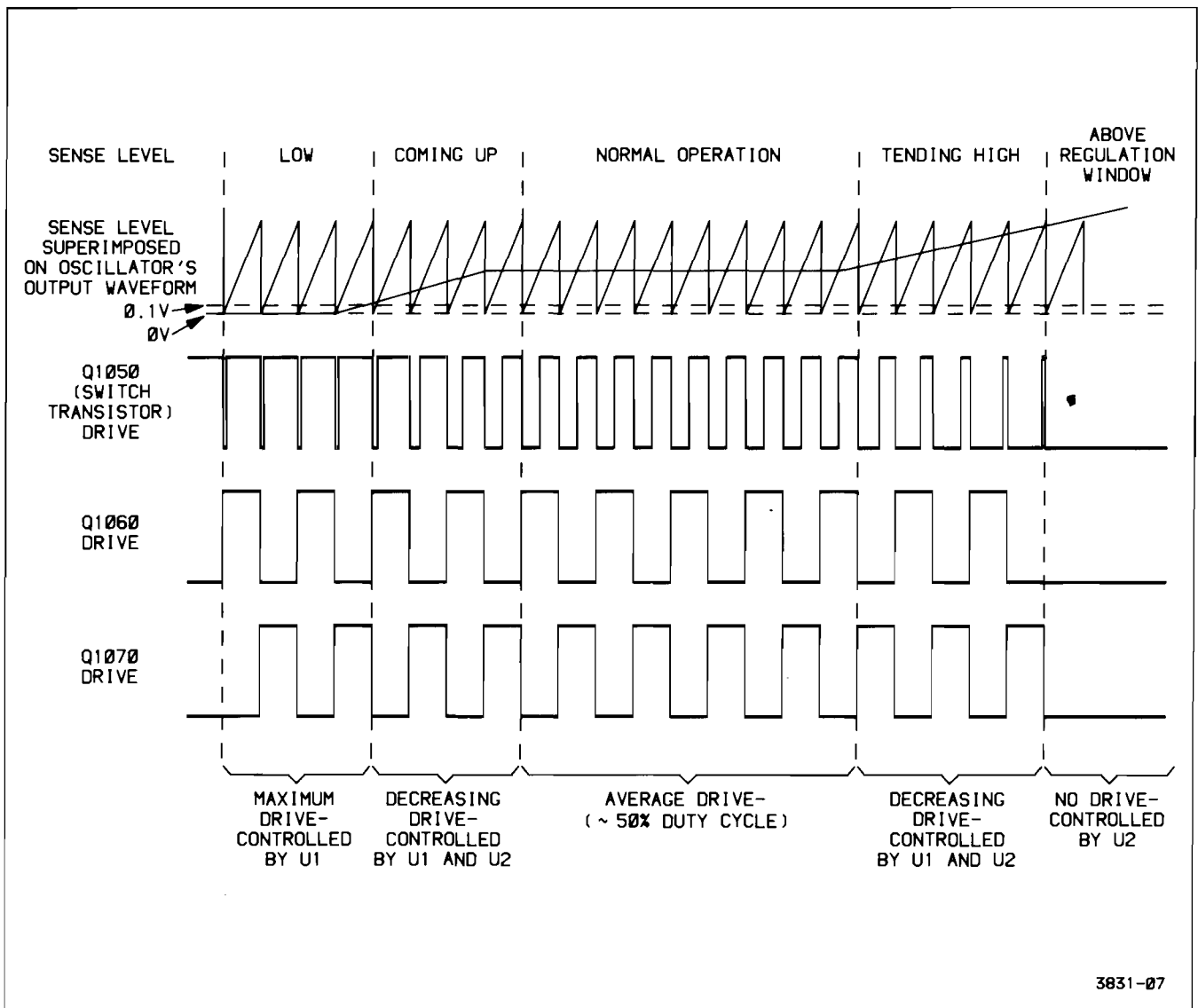

Figure 3-10. Timing relationships of the Inverter Drive signals.

PREREGULATION. Once the initial charging at power-up is accomplished, as just described, the voltage-sensing circuitry begins controlling the Inverter switching action. The actual voltage sensing is done by error amplifier U2. The level at the center tap of output transformer T1060 is applied to pin 1 and is compared to the reference established by R1045 and R1046 at pin 2. If the sensed level at pin 1 is lower than the reference level (as it will always be for the first few switching cycles), the output of error-amplifier U2 will be LO. The LO, applied to the inverting input of U3, results in a long-duty-cycle drive signal to transistor Q1050 (via CR1030). Since the Inverter Drive stage will alternately turn either Q1060 or Q1070 on, relatively large current pulses will result in the primary winding of inverter output transformer T1060.

These large current pulses, over the period of a few cycles, will increase the charge on the storage capacitors on the secondary side of the transformer and will reduce the current demand on the inverter output transformer. As the demand increases, the voltage across the primary winding will increase until it reaches the point where the two inputs of U2 are at the same potential. At this point, the output of U2 (to U3) will settle to a level approximately equal to the midpoint of the triangular waveform applied to the other input of U3. The resulting drive signal has an approximate 50% duty cycle and will respond to changes in either the ac line voltage or supply load conditions. Depending on the output levels sensed, the duty cycle of the drive signal will change (sensed level rises or falls with respect to the triangular waveform) to hold the secondary supplies at their proper levels.

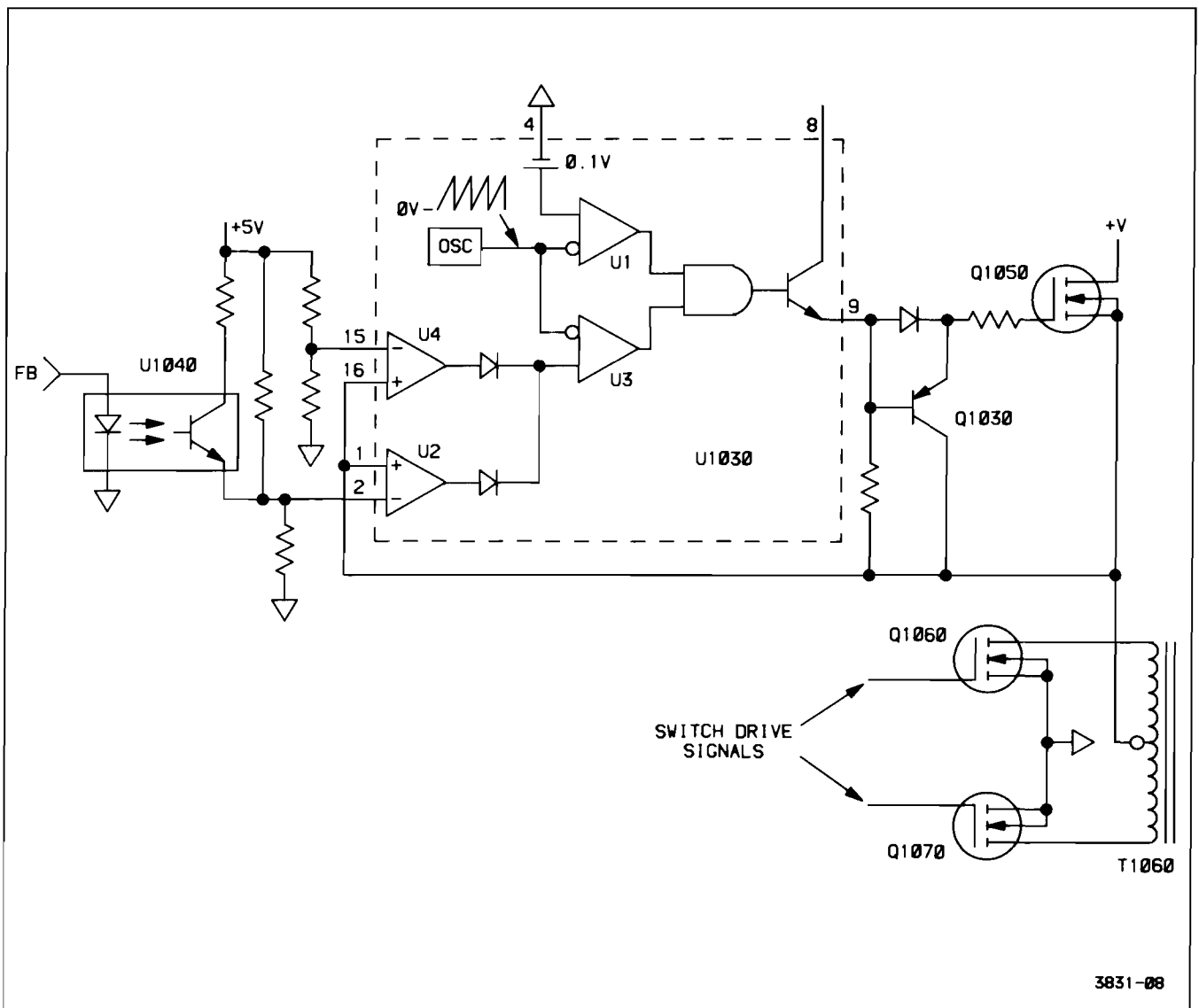

Figure 3-11. Simplified schematic of control network.

Theory of Operation—2445A/2455A Service

Opto-isolator U1040 and resistor R1044 form a control network that allows a voltage sensed at the feedback input (FB) to slightly alter the voltage-sense reference applied to pin 2 of U2. The FB signal is generated by the +5 V Inverter Feedback amplifier (U1371, diagram 10) and is directly related to the level of the +5V_D supply line. Base drive to the shunt transistor (in opto-isolator U1040) is increased should the FB signal go below its nominal value. Additional current is shunted around R1045 (via R1044) and raises the voltage-sense reference level to error-amplifier U2. This increases the voltage applied to the primary winding of the output transformer, since U2 sensing depends on a balanced condition. Higher currents are induced in the secondary windings, and the secondary voltages begin to return to their nominal values. As the +5V_D line returns to its nominal level, base drive to the shunt transistor will be reduced and the voltage in the primary winding will follow. Should the FB signal level tend too high, opposite control responses occur. Further information about the FB signal is given in the +5 V Inverter Feedback description.

Error amplifier U4 and the voltage divider composed of R1035 and R1031 provide a backup sensing circuit. Its operation is similar to that of error amplifier U2, just described, but it senses at a slightly higher level. As long as U2 is operating properly, U4 will be inactive. However, should a failure occur in the U2 sensing circuitry, the voltage on the primary winding of T1060 will rise to the sensing level at pin 15 of U4. Sense amplifier U4 will then take over, preventing a damaging over-voltage condition.

Inverter Drive

The Inverter Drive circuit performs the necessary switching to drive the inverter output transformer. Like the Preregulator Control IC, the Inverter Drive circuit requires an independent power supply, since it must be operational before any of the secondary supply voltages can be generated.

INVERTER DRIVE POWER SUPPLY. This power supply consists of Q1062, VR1062, and their associated components. As power is first applied, the initial charging current through T1050 induces a current in the transformer secondary winding (pins 8 and 9). The alternating current is rectified by the diode bridge composed of CR1062, CR1063, CR1064, and CR1065 and stored in C1066, providing power for the Inverter Drive circuitry.

When the Preregulator Control IC turns switching transistor Q1050 on for the first time, the charge stored on C1066 during the initial charging period is sufficient to properly turn on one of the current-switching transistors (either Q1060 or Q1070) for the first cycle. After that, the alternating drive signals continue to induce current into the

secondary winding of T1050 to provide operating power as long as the instrument is turned on.

The current rectified by the diode bridge and stored on capacitor C1066 is regulated down to the required voltage level by R1061, VR1062, and Q1062. Zener diode VR1062 references emitter-follower Q1062 and holds the supply output at approximately +11.4 V.

INVERTER DRIVE GENERATOR. The Inverter Drive generator consists of U1062, U1064, U1066, switching transistors Q1060, Q1070 and their associated components. The circuitry alternately switches current through each leg of the output transformer (T1060) primary winding and produces the ac current required for transformer action.

Out-of-phase input signals to comparator U1062C come from two resistive voltage dividers placed in either leg of one secondary winding of T1050. The comparator detects the phase changes (crossover points) of the secondary current caused as Q1050 switches on and off. Every complete on-off cycle of Q1050 produces a positive clock at pin 14 of U1062C that toggles flip-flop U1064B. The toggling alternately turns switching transistors Q1060 and Q1070 on, each with an approximate 50% duty cycle.

Comparators U1062A and U1062B, at the Q and \bar{Q} output of the flip-flop, detect the precise crossing point of the toggling drive signals and ensure that only one switching transistor will be on at any one time. These mutually-exclusive drive signals are buffered by inverters U1066A and U1066B and applied to switching transistors Q1060 and Q1070 to alternately turn them on and off at one-half the switching rate of Q1050. By alternately switching opposite ends of the primary winding to ground, the current flowing through switching transistor Q1050 will flow alternately in each half of the primary winding. This produces ac voltages at the secondary windings that are then rectified, providing the various unregulated dc supply voltages.

Current Limit

The Current Limit circuit, composed of transistor Q1040 and the associated components, limits the maximum current flow in the output transformer to about 1 ampere. Resistor R1040 (connected to the Preregulator Control IC +15 V supply) forward biases germanium diode CR1040 and applies approximately +0.3 V across the base-to-emitter junction of Q1040. Current flowing to the output transformer develops a voltage drop across R1050 that adds to the bias developed by CR1040. As the current to the transformer increases, the voltage drop across R1050 also increases until, at around 1 A, the combined voltage drop across R1050 and CR1040 forward biases transistor

Q1040. The base of Q1022 is pulled negative through R1042, and the +15 V supply for the Preregulator IC turns off (see Preregulator Control description). The power supply will try to restart itself; but, as long as the excessive-current condition persists, the current-limit circuit will keep shutting the supply down, protecting the instrument.

Rectifiers

The rectifiers convert the alternating current from the secondary windings of inverter output transformer T1060 to the various dc supply voltages required by the instrument. Rectification is done by conventional diode rectifier circuits, and filtering is done by conventional LC networks.

The +87 V unregulated supply is produced by a voltage-doubler circuit. The positive plate of C1130 at the anode of CR1132 is referenced at approximately +45 V through diode CR1131 (to the +42 V unregulated supply). As the positive half cycle from the 42 V secondary winding (actually about +45 V peak) is applied to the negative plate of C1130, the positive plate is elevated to a peak value of approximately +90 V. Diode CR1132 becomes forward biased and storage capacitor C1132 is charged to about +90 V. Following cycles replenish the charge drawn off by the loads on the +87 V supply line.

Line Signal

A sample of the ac line voltage is coupled to the Trigger circuit by transformer T1229 and provides the LINE TRIG signal to the Trigger hybrid. Transformer current is limited to a safe value by resistors R1014 and R1015 placed in series with the primary winding leads. The transformer's output characteristics are matched to the input of the Trigger circuit hybrid by R1208 and C1208.

Line Up Signal

The circuit composed of Q1029, opto-isolator U1029, and their associated components, detects when power has been applied to the instrument and the Preregulator Control power supply is functioning properly. When the rectified line voltage reaches proper operating voltage, the voltage divider composed of R1027 and R1028 forward biases Q1029. As soon as the Preregulator Control power supply turns on, current flows through R1029, Q1029, and the opto-isolator LED. The illuminated LED saturates transistor U1029 and the LINE UP signal to the Power-Up Delay circuit (diagram 1) is pulled HI, indicating that the Preregulator Control circuit should now be functioning properly.

POWER DOWN. When instrument power is turned off, the voltage across the primary storage capacitors (C1021

and C1022) begins to fall as the capacitors discharge. As the voltage drops, the bias current through R1027 to the base of Q1029 also drops until the bias voltage across R1028 reaches a point about 2 V above the average transformer drive level at pin 2 of U1029. At this point, Q1029 turns off, and the LINE UP signal to the Power-Up Delay circuit goes LO. This LO signals the Microprocessor that it should start its power down routine.

The Line Up circuit tells the Microprocessor that the primary capacitors have started discharging while there is still a stored charge (set by R1027 and R1028) about 40% in excess of that required to keep the power supply voltages in regulation. This allows the Microprocessor to complete the power-down sequence before the supplies drop below their normal operating level. Further information about the power-down sequence is given in the Microprocessor Reset Control description.

Fan Circuit

Fan motor B10 is driven by adjustable three terminal regulator U1110. The fan's speed is determined by the voltage supplied by U1110 and varies with ambient temperature.

As the ambient temperature in the cabinet increases, the resistance of thermistor RT1110 decreases causing more current to flow in R1112. This causes the voltage at pin 2 and therefore the voltage at pin 3 of U1110 to increase, and the fan motor speed increases to provide more cooling capacity.

LOW-VOLTAGE REGULATORS

The Low-Voltage Regulators remove ac noise and ripple from the various unregulated dc supply voltages. Each regulator output is automatically current limited if the output current exceeds the requirements of a normally functioning instrument. This limiting prevents any further component damage.

+ 10 Volt Reference

Each of the power-supply regulators control their respective outputs by comparing their output voltages to a known reference level. In order to maintain stable supply voltages, the reference voltage must itself be highly stable. The circuit composed of U1290, U1300C and associated components establish this reference.

Resistor R1400 and capacitor C1400 form an RC filter network that smooths the unregulated +15 volt supply

Theory of Operation—2445A/2455A Service

before it is applied to voltage-reference IC U1290. The +2.5 V output from pin 2 of U1290 is applied to the noninverting input of operational amplifier U1300C. The output of U1300C is the source of the +10 V reference level used by the various regulators. The output level is set by the voltage divider formed by R1291, R1293, and potentiometer R1292. The Volt Ref Adjust pot in the divider allows the reference level to be precisely set. Zener diode VR1292 prevents the reference from exceeding +11 volts should a failure in the reference circuitry occur.

+ 87 V Regulator

The +87 V Regulator is composed of Q1220, Q1221, Q1222, Q1223, U1281A, and their associated components. The circuit regulates and limits both the voltage and current of the supply output.

Initially, as power is applied, the voltage applied to pin 2 of U1281A from the voltage divider formed by R1227 and R1228 is lower than the +10 V reference level applied to pin 3. The output of U1281A is forced high, reverse biasing the base-emitter junction of Q1222 and turning it completely off. With Q1222 off, all the current through R1212 is supplied as base current to Darlington transistor pair Q1221 and Q1220, and maximum current flows in series-pass transistor Q1220. This charges up the various loads on the supply line, and the output level charges positive.

As the regulator output charges toward +87 V, the voltage divider applies a positive-going voltage to the inverting input of U1281A. When the output level reaches +87 volts, the inverting input reaches the +10 V reference at the noninverting input. The output voltage at pin 1 of U1281A will go negative and the base-emitter junction of Q1222 will be biased into the active region. As Q1222 turns on, base drive for the Darlington pair (Q1221 and pass transistor Q1220) is reduced. The output will be held at the level required (+87 V) for voltage at the two inputs of amplifier U1281A to be in balance.

Current limiting is a foldback design and is performed by Q1223 and its associated components. Under normal current demand conditions, Q1223 is off. If the regulator output current exceeds approximately 100mA (as it might if a component fails), the voltage drop across R1221 and CR1220 reaches a point that forward biases Q1223 via the bias divider formed by R1222 and R1223. As Q1223 turns on, a portion of the base-drive current to Q1221 is shunted away by Q1223. This reduces the base-drive current (and thus the output current) of series-pass transistor Q1220.

+42 V Regulator

The circuit configuration and operation of the +42 V Regulator is identical to that of the +82 V Regulator. Current limiting of the +42 V supply occurs at approximately 400 mA. Base drive to Darlington pair Q1241 and Q1240 is via R1244 and is dependent on proper operation of the +87 Volt Regulator. This dependency ensures that the relative polarities of the two supplies are never reversed (preventing semiconductor-junction damage in the associated load circuitry).

+ 15 V Regulator

The +15 V Regulator uses three-terminal regulator U1260 and operational amplifiers U1371A and U1371B, arranged as voltage sensors, to achieve regulation of the +15 V supply. The three-terminal regulator holds its output voltage at pin 2 at 1.25 volts more positive than the reference input level at pin 1. The voltage at the reference pin is established by current flow in either diode CR1262 or CR1263.

Resistors R1261 and R1262 at the regulator output divide the +15 V level down for comparison with the +10 V reference applied to pin 5 of operational amplifier U1371B. When the input voltage at pin 6 (supplied by the voltage divider) is lower than the +10 V reference, the output of amplifier U1371B is high and the output voltage of U1260 is allowed to rise. As the regulator output reaches +15 V, the voltage on pin 6 of U1371B approaches the level on pin 5, and the amplifier begins sinking current away from the reference pin of the three-terminal regulator via diode CR1263. This lowers the voltage on the reference pin and holds the output at +15 V.

The other voltage-sensing amplifier (U1371A) ensures that the relative polarity between the +15 V supply and the +42 V supply is maintained, preventing component damage in the load circuitry. Should the +42 V supply be pulled below +15 V (excessive loading or supply failure), the voltage at pin 3 of U1371A falls below the voltage at pin 2 and the amplifier output voltage goes low. This forward biases CR1262 and lowers the reference voltage for U1260, reducing the output voltage.

Current limiting for the +15 V supply is provided by the internal circuitry of the three-terminal regulator.

+ 5 V Regulator

Regulation of the +5 V supply is provided by a circuit similar to those of the +87 V and the +42 V Regulators. As long as the relative polarity between the +15 V and the +5 V supplies is maintained, base drive to Q1281 is

supplied through R1283. The current through Q1281 provides base drive for series-pass transistor Q1280.

When voltage-sense amplifier U1300B detects that the output voltage has reached +5 V, it begins shunting base-drive current away from Q1281 via CR1281 and holds the output voltage constant.

Current limiting for the +5 V supply is done by U1300A and associated components. Under normal current-demand conditions, the output of U1300A is high and diode CR1282 is reverse biased. However, should the current through the current-sense resistor R1281 reach approximately 2 A, the voltage developed across R1281 will raise the voltage at pin 2 of U1300A (via divider R1282 and R1286) to a level equal to that at pin 3. This causes the output of U1300A to go low, forward biasing CR1282. This sinks base drive current away from Q1281 and lowers the output current in series-pass transistor Q1280.

— 15 V Regulator

Operation of the —15 V Regulator, composed of three-terminal regulator U1330, operational amplifier U1270C, and their associated components, is similar to that of the +15 V Regulator with the following major changes. The control voltage at the three-terminal regulator's reference pin (pin 1) is established by the current through series-resistors R1333 and R1334. The reference pin is clamped by CR1332 at about —5.6 V should a failure in the sensing network occur. (Clamping also prevents latchup of the operational amplifier during start-up of the power supply.) Finally, the sensing divider formed by R1331 and R1332 is referenced to the +10 V reference instead of ground to enable sensing of negative voltage.

— 8 V Regulator

Operation of the —8 V Regulator is similar to that of the +87 V and +42 V Regulators. Due to the lower operating voltages of the —8V Regulator the common-base transistor present in both the +87 V and the +42 V is not required. Current limiting in the —8 V supply occurs at about 480 mA.

— 5 V Regulator

Operation of the —5 Volt Regulator is similar to that of the +5 V Regulator. Current limiting in the —5 V supply occurs at about 2 A.

+5 V Inverter Feedback

Operational amplifier U1371C and associated com-

ponents are configured as a frequency-compensated voltage-sensing network. The circuit monitors the +5 V digital power supply line from the rectifiers and provides feedback to the Preregulator Control IC (U1030) via optoisolator U1040 (both on diagram 9). The feedback is used to slightly vary the voltage-sensing characteristics of the Preregulator Control circuitry. The feedback (FB) signal slightly varies the voltage to the Inverter output transformer and holds the output of the 5 V secondary windings at an optimum level. Output levels of the other secondary windings are related to the +5 V_D level and are also held at their optimum values. This technique minimizes power losses in the series-pass transistors and increases regulator reliability.

Power-Up Delay

The Power-Up Delay circuit, composed of Q1370, Q1376, U1371D, and the associated components, ensures that the various regulated power supplies have time to reach their proper operating voltages before signaling the Microprocessor that the power supplies are up.

When power is first applied, a LINE UP signal from the Preregulator Control circuit goes HI, indicating that the power switch has been closed and that ample supply voltage is available for driving the Inverter transformer. The HI is applied to the base of Q1370, but since the collector is not properly biased yet, no transistor current will flow. As the Inverter begins to run, the various voltages from the secondary rectifiers begin coming up to their proper levels. A +2.5 V reference voltage is applied to operational amplifier U1371D pin 12 and forces the output high, biasing Q1376 on.

Before any of the Low-Voltage Regulators may function properly, the +10 V reference voltage must be established as previously described. When the +15 V Regulator turns on, current flows through Q1370, and pin 13 of U1371D is pulled above the +2.5 V reference through divider R1370 and R1372. The output of U1371D goes low, turning off Q1376.

When power to the instrument is turned off, the LINE UP signal goes LO (as explained in the Line Up Signal description). The falling LINE UP signal turns Q1370 off and drives the output of U1371D high. The output level of U1371D turns on Q1376 on and pulls the PWR UP signal to the Microprocessor LO. This LO initiates the power-down sequence used to shut down the instrument in an orderly fashion. The delay between the time that the PWR UP signal goes LO and when the regulated power supplies fall below their normal operating levels provides ample time for the Microprocessor to complete the power-down sequence.

Theory of Operation—2445A/2455A Service

Power Supply Shutdown

Phosphor damage can occur to the CRT if certain regulated power supply voltages are overloaded due to excessive current draw by their loads. U1300C and its associated circuitry monitor the +15 V and the +5 V Regulator supplies. The +87 V and the +42 V Regulator supplies are monitored via R1294 and R1295 respectively. If any of these regulated supplies exceed their limit, current is sourced to U1300D (pin 13). When this happens, the +10 V Reference begins to drop which in turn lowers all the regulated supplies. This causes the high voltage oscillator to shutdown preventing damage to the CRT. Q1290 and its associated circuitry allows the +10 V Reference to come up and stabilize before the shutdown circuitry is enabled. Jumper J208 is used to disconnect the shutdown circuitry for troubleshooting purposes.

POWER DISTRIBUTION

Schematic diagrams 11 and 12 illustrate the power distribution of the instrument. The connections to the labeled

boxes (representing the hybrids and ICs) show the power connections to each device, while connections to non-power lines are shown by the component and schematic number. Power supply decoupling is done with traditional LRC networks as shown on the diagrams.

Several intermediate supply voltages are generated by devices shown on diagrams 11 and 12. An approximate +32 volt supply for the A and B Sweeps is developed by emitter-follower Q700 and its associated components. Zener diodes VR125 and VR225 develop approximate +6.2 volt supplies for the CH 1 and CH 2 Preamps respectively, and zener diode VR2805 establishes an approximate -6.8 volt supply for U2800 and U2805.

INTERCONNECTIONS

Schematic diagram 13 illustrates the circuit board interconnections of the instrument. Connector numbers and cabling types are shown.

PERFORMANCE CHECK AND FUNCTIONAL VERIFICATION PROCEDURE

INTRODUCTION

This procedure is used to verify proper operation of instrument controls and to check the instrument's performance against the requirements listed in the "Specification" (Section 1). This procedure verifies instrument function and may be used to determine need for readjustment. These checks may also be used as an acceptance test and as a preliminary troubleshooting aid.

Removing the wrap-around cabinet is not necessary to perform this procedure. All checks are made using the operator accessible front- and rear-panel controls and connectors.

Within the procedure, steps to verify proper operation of an instrument control or function that is not specified in the "Specification" section begin with the word "VERIFY". These functions ARE NOT specifications and should not be interpreted as such. Steps to check performance specifications begin with the word "CHECK".

PREPARATION

Test equipment items 1 through 18 listed in Table 4-1 are required to perform this procedure. The specific pieces of equipment required to perform the checks within each section are listed at the beginning of that section. The item numbers in parenthesis next to each piece of equipment refer to the numbered equipment list of Table 4-1. Items 19 through 23 are used only for instrument calibration (see the Adjustment Procedure in Section 5).

Before performing this procedure, ensure that the LINE VOLTAGE SELECTOR switch is set for the ac power source being used (see "Preparation for Use" in Section 2). Connect the instrument to be checked and the test

equipment to an appropriate power source. Turn the instrument on and ensure that no error message is displayed on the CRT. If an error message is present, have the instrument repaired or calibrated by a qualified service technician before performing this procedure.

The procedure is divided into sections to permit functional and performance verifications of individual sections of the instrument without performing the entire procedure. Perform all steps within a section, both in the sequence presented and in their entirety, to ensure that control settings are correct for the following step.

When performing partial procedures, the Initial Control Settings at the first of the section should be set up first; then make any changes noted at the first of the subsection to be performed. When performing the procedures in sequence, merely change those controls that have changed from the previous step.

NOTE

In order to see a channel's VOLTS/DIV setting, the channel must be selected using the VERTICAL MODE switches.

On instruments with Option 06 or 09 (CTT) installed: selecting Intensified, Alternate, or B Horizontal Mode will automatically enable the Counter/Timer/ Trigger option for precision Delay, Delta Time, and 1/Delta Time measurements. Several sections of the Performance Verification Procedure specify various delay settings for B Trigger in either the RUN AFTER DELAY, TRIGGERED AFTER DELAY, or TRIG Δ DELAY mode. Procedure steps involving delay settings that the CTT option will affect have alternate instructions listed.

**Table 4-1
Test Equipment Required**

Item and Description	Minimum Specification	Use	Example of Applicable Test Equipment
1. Variable Power Supply	Variable output voltage: 0 V to +16 V.	Check 50 Ω input overload switching.	TEKTRONIX PS 503A.
2. Leveled Sine-Wave Generator (Primary)	Frequency: 50 kHz to 250 MHz. Output: 0 V to 5 V. Reference frequency: 50 kHz.	For CTT check Accuracy: 1ppm lockable to WWV, jitter <50 ps	Check Bandwidth and triggering.
3. Calibration Generator	Fast-rise, low aberration amplitudes: to 1 V. Rise time: 1 ns or less. Repetition rate: 1 kHz to 100 kHz. Precision amplitudes: 0.01 V to 50 V \pm 0.25%.	Signal source for gain and transient response.	TEKTRONIX PG 506.
4. Leveled Sine-Wave Generator (Secondary)	Frequency: 245 to 500 MHz. Output: 0 V to 5 V. Reference frequency: 50 kHz.	Check bandwidth and triggering.	TEKTRONIX SG 504 with Leveling head.
5. Function Generator	Repetition rate: 60 Hz to 1 MHz. Output to 15 V p-p.	Check triggers and coupling.	TEKTRONIX FG 501A.
6. Time-Mark Generator	Markers: 2 ns to 5 s in a 1-2-5 sequence. Marker accuracy: \pm 0.1%. For CTT checks accuracy: \pm 0.00005%.	Check horizontal timing and CTT.	TEKTRONIX TG 501. CTT requires TG501A option 01.
7. Oscilloscope with 10X Standard Accessory Probe	Bandwidth: 150 MHz/250 MHz. General Purpose.	Check power supply ripple and output signals. Troubleshooting.	TEKTRONIX 2445A/2455A.
8. T-Connector (2 required)	Impedance: 50 Ω . Connectors: BNC.	Signal interconnection.	TEKTRONIX Part Number 103-0030-00.
9. Precision BNC Cable	Impedance: 50 Ω . Connectors: BNC. Length: 36 in.	Signal interconnection.	TEKTRONIX Part Number 012-0482-00.
10. BNC Cable (2 required)	Impedance: 50 Ω . Connectors: BNC. Length: 42 in.	Signal interconnection.	TEKTRONIX Part Number 012-0057-01.
11. Dual-Input Coupler	Connectors: BNC female-to-dual-BNC male.	Signal interconnection.	TEKTRONIX Part Number 067-0525-02.
12. Termination (2 required)	Impedance: 50 Ω . Connectors: BNC.	Signal interconnection.	TEKTRONIX Part Number 011-0049-01.
13. Adapter	Subminiature probe-tip-to-BNC.	Signal interconnection.	TEKTRONIX Part Number 013-0195-00.
14. Adapter	BNC female-to-BNC female.	Signal interconnection.	TEKTRONIX Part Number 103-0028-00.
15. Adapter	Connectors: BNC female-to-dual banana.	Signal interconnection.	TEKTRONIX Part Number 103-0090-00.

Table 4-1 (cont)

Item and Description	Minimum Specification	Use	Example of Applicable Test Equipment
16. Attenuator	Attenuation factor: 2X. Impedance: 50 Ω . Connectors: BNC.	Signal attenuation.	TEKTRONIX Part Number 011-0069-02.
17. Attenuator	Attenuation factor: 5X. Impedance: 50 Ω . Connectors: BNC.	Signal attenuation.	TEKTRONIX Part Number 011-0060-02.
18. Attenuator	Attenuation factor: 10X. Impedance: 50 Ω . Connectors: BNC.	Signal attenuation.	TEKTRONIX Part Number 011-0059-02.
19. Digital Multimeter (DMM)	DC volts range to +20 V. Accuracy: $\pm 0.2\%$.	Check power supplies and CALIBRATOR.	TEKTRONIX DM 502A.
20. Low-Capacitance Alignment Tool	Shaft length: 2 in.	Adjust variable resistors and capacitors.	TEKTRONIX Part Number 003-0675-00.
21. 1X Probe	Attenuation: 1X. Bandpass: <20 MHz.	Check power supply ripple.	TEKTRONIX P6101-01.
22. Normalizer	Input resistance: 1 M Ω . Input capacitance: 15 pf.	Check input capacitance.	TEKTRONIX Part Number 067-0537-00.
23. Tunnel Diode Pulser	Rise time: 125 ps or less.	Check transient response.	TEKTRONIX Part Number 067-0681-01.
24. Pulse Generator (2 required)	Frequency: 10 MHz. Pulse width: 50 ns. Pulse width accuracy: 5%. Positive trigger input, 1 V to 5 V into 50 Ohms. Positive trigger output, 1 V into 50 Ohms. Variable pulse duration.	CTT Checks.	TEKTRONIX PG502 Pulse Generator.
25. Adapter	Connectors: BNC male-to-subminiature-probe tip.	CTT Checks.	TEKTRONIX Part Number 013-0195-00.
26. Adapter (2 required)	Connectors: BNC male-to-dual-binding.	CTT Checks.	TEKTRONIX Part Number 103-0035-00.

VERTICAL

Equipment Required (see Table 4-1)

Power Supply (item 1)	50 Ω BNC Termination (Item 12)
Primary Leveled Sine-Wave Generator (Item 2)	Subminiature Probe Tip-to-BNC Adapter (Item 13)
Calibration Generator (Item 3)	BNC Female-to-BNC Female Adapter (Item 14)
Secondary Leveled Sine-Wave Generator (Item 4)	BNC Female-to-Dual Banana Adapter (Item 15)
10X Probe (supplied with oscilloscope) (Item 7)	2X Attenuator (Item 16)
Precision 50 Ω BNC Cable (Item 9)	5X Attenuator (Item 17)
50 Ω BNC Cable (Item 10)	10X Attenuator (Item 18)
Dual-Input Coupler (Item 11)	

INITIAL CONTROL SETTINGS

Control settings not listed do not affect the procedure.

a. Set:

NOTE

Select channels to set VOLTS/DIV.

VOLTS/DIV

CH 1 and CH 2	1 V
CH 1 and CH 2 VAR	In detent
CH 3 and CH 4	0.1V

VERTICAL MODE

CH 1	On
CH 2, CH 3, CH 4, ADD, and INVERT	Off
CHOP/ALT VERTICAL MODE	ALT
20 MHz BW LIMIT	Off

Input Coupling

CH 1 and CH 2	1 M Ω GND
---------------	------------------

HORIZONTAL

A SEC/DIV	10 ms (knob in)
SEC/DIV VAR	In detent
X10 MAG	Off
TRACE SEP	Fully CW

Delta

Δt and ΔV	Off (press and release until associated readout is off)
TRACKING	Off

TRIGGER

HOLDOFF	Fully CCW
LEVEL	Midrange
SLOPE	+ (plus)
A/B TRIG	SELECTA
MODE	AUTO LVL
SOURCE	VERT
COUPLING	DC

1. Verify CH 1 and CH 2, 50 Ω OVERLOAD protection.

a. Connect the Power Supply to the CH 1 OR X input connector via a 50 Ω BNC cable and a BNC female-to-dual banana adapter.

b. Using the CH 1 VERTICAL POSITION control, position the trace on the bottom horizontal graticule line.

c. Change CH 1 Input Coupling to 1 M Ω DC.

d. Turn the Power Supply on.

e. Adjust the Power Supply output level until the CH 1 trace rises to 1 division above the center graticule line (+5 V).

f. Change CH 1 Input Coupling to 50 Ω DC.

g. VERIFY—For a period of one minute, the readout display does not indicate any overload condition (50 Ω OVERLOAD).

h. Change the CH 1 VOLTS/DIV control to 5 V and the CH 1 Input Coupling to 1 M Ω DC.

i. Increase the Power Supply output level until the CH 1 trace rises to the center graticule line (+20 V).



To prevent damage to the input circuitry when in 50 Ω DC, the 20 V source must not be applied to the CH 1 OR X or CH 2 input connectors for longer than 15 seconds. If the automatic OVERLOAD switching does not occur within 15 seconds, turn the Power Supply off immediately.

j. Set the CH 1 Input Coupling to 50 Ω DC.

k. VERIFY—Within 15 seconds after CH 1 input coupling is set to 50 Ω DC, the readout display indicates 50 Ω OVERLOAD, the CH 1 Input Coupling changes to 1 M Ω GND automatically, and the trace returns to the bottom horizontal graticule line.

l. Turn the Power Supply Off.

m. Disconnect the Power Supply from CH 1 input.

n. Clear the OVERLOAD condition by pressing the upper CH 1 Input Coupling button.

o. VERIFY—The CH 1, 1 M Ω DC indicator is lit and the readout display no longer indicates 50 Ω OVERLOAD.

p. Set the VERTICAL MODE buttons to display Channel 2 and repeat parts a through o to verify 50 Ω OVERLOAD protection for Channel 2.

2. Check CH 1 and CH 2 Low-Frequency AC Coupling.

a. Set:

NOTE

Select channels to set VOLTS/DIV.

VOLTS/DIV

CH 1 and CH 2 100mv

VERTICAL MODE

CH 1 On
CH 2 Off

Input Coupling

CH 1 and CH 2 1 M Ω GND

HORIZONTAL

A SEC/DIV 10 ms (knob in)

b. Connect the CALIBRATOR output signal to the CH 1 OR X input connector using a 1X probe.

c. Position the ground-reference trace 2 divisions below the center horizontal graticule line.

d. Set the CH 1 Input Coupling to 1 M Ω DC.

e. CHECK—Displayed signal is vertically centered and has an amplitude of 3.88 to 4.12 divisions.

f. Set the Channel 1 Input Coupling to the upper 1 M Ω GND position.

g. Using the CH 1 POSITION control, align the trace with the center horizontal graticule line.

h. Set the Channel 1 Input Coupling to 1 M Ω AC.

i. CHECK—Displayed signal is a tilted square wave, 4.36 to 5.37 divisions in amplitude, vertically centered on the graticule.

Performance Check—2445A/2455A Service

j. Move the probe to the Channel 2 input connector.

NOTE

The instrument must have had at least 20 minutes warmup prior to performing the following steps.

k. Set the VERTICAL MODE buttons to deselect Channel 1 and display Channel 2.

NOTE

Instruments with TV OPTION 05 have a TV CLAMP feature that is enabled by pushing the upper CH 2 INPUT COUPLING button while in AC COUPLING. The letters TVC appear in the top right readout when this mode is selected. Push the lower CH 2 INPUT COUPLING button to return to normal AC coupling.

l. Repeat parts c through i for Channel 2.

m. Disconnect the test setup.

b. Momentarily press and hold both the CH 1 and CH 2 upper Input Coupling buttons until a moving dot display replaces the normal signal. This performs a DC Balance of CH 1 and CH 2 and the readout displays DC BALANCE IN PROGRESS.

c. When the signal and readout displays automatically return to normal, set the CH 1 and CH 2 Input Coupling to 1 MΩ DC.

d. Connect the Calibration Generator to the CH 1 OR X input connector via a 50 Ω BNC cable. Do not use a termination.

3. Check CH 1 and CH 2 VOLTS/DIV, CH 2 INVERT, ΔV and TRIGGER LEVEL Readout Accuracies, Variable VOLTS/DIV, Vertical Linearity, and ADD.

a. Set:

e. CHECK—CH 1 and CH 2 VOLTS/DIV, ΔV, and TRIGGER LEVEL readout accuracies as follows:

1. Set VOLTS/DIV control to the first position listed in Table 4-2.
2. Set the Calibration Generator STD AMPLITUDE output level to the corresponding Standard Amplitude Input Level in Table 4-2.

NOTE

Select channels to set VOLTS/DIV.

VOLTS/DIV

CH 1 and CH 2 2 mV

NOTE

To properly verify TRIGGER LEVEL Readout Accuracy, the Calibration Generator's STD AMPLITUDE output must have rising and falling transition times (10% to 90%) > 20 ns. No overshoot should appear on the waveform.

VERTICAL MODE

CH 1 On
 CH 2 Off
 CH 1 and CH 2 1 MΩ DC
 BW LIMIT On

HORIZONTAL

A SEC/DIV 1 ms (knob in)
 ΔV On (press and release for a ΔV readout)

3. Verify that the generator output meets the requirements noted above.
4. Use the VERTICAL POSITION control to set the bottom of the signal 2 divisions below graticule center.
5. Rotate the Δ REF OR DLY POS control to align the reference cursor with the bottom of the waveform.

TRIGGER

MODE AUTO
 COUPLING DC

6. Rotate the Δ control to align the delta cursor with the top of the signal display.
7. CHECK—Vertical Deflection Accuracy (measured against the graticule) and ΔV Readout Accuracy are within the limits listed in Table 4-2.
8. Set the TRIGGER LEVEL control at the most positive voltage that produces a barely triggered, jittering display for each position of SLOPE.
9. CHECK—The A Trigger Level readings are within the limits given in the +Peak column of Table 4-2.
10. Set the TRIGGER LEVEL control at the most negative voltage that produces a barely triggered, jittering display for each position of SLOPE.
11. CHECK—The A Trigger Level readings are within the limits given in the –Peak column of Table 4-2.
12. Set the TRIGGER LEVEL for a stable display.
13. Pull the SEC/DIV knob out.
14. Set:

B TRIGGER

MODE	TRIG AFT DLY
SOURCE	VERT
COUPLING	DC
SLOPE	+

NOTE

On CTT instruments, rotate the Δ REF OR DLY POS control for the specified delay. As the control is rotated, the readout delay value will be followed by the word "SET". This value shows the approximate delay. A few seconds after control movement has stopped, the word "SET" will disappear and the readout delay value as measured by the CTT will appear. This is normal operation and not cause for concern.

15. Adjust Δ REF OR DLY POS control for a delay reading of 0.000 ms.
16. Set the TRIGGER LEVEL control to the most positive voltage that produces an intensified point on the waveform display for each position of SLOPE.
17. CHECK—The B Trigger Level readings are within the limits given in the +Peak column of Table 4-2.
18. Set the TRIGGER LEVEL control to the most negative voltage that produces an intensified point on the waveform display for each position of SLOPE.
19. CHECK—The B Trigger Level readings are within the limits given in the –Peak column of Table 4-2.

NOTE

On CTT instruments, repeat sections 16-19 for TRIG Δ DLY trigger mode using the +Peak and –Peak columns of Table 4-2.

20. Push the SEC/DIV knob in.
21. Change the VOLTS/DIV to the next position listed in Table 4-2.
22. Set the Calibration Generator to the corresponding signal amplitude setting.
23. Press and release the ΔV pushbutton to obtain the ΔV readout display.
24. Repeat subparts 4 through 23 of part e for each VOLTS/DIV setting listed in Table 4-2.
25. Set the TRIGGER COUPLING to NOISE REJ.
26. Set the CH 1 VOLTS/DIV to 50 mV.

Performance Check—2445A/2455A Service

27. Set the Calibration Generator STD AMPLITUDE output level to 0.2 V.

28. CHECK—Trigger Level Readout is within the limits given in Table 4-2 for NOISE REJ Coupling.

f. Return the TRIGGER COUPLING to DC.

g. Set the CH 1 VOLTS/DIV and the Calibration Generator output level to produce a vertical signal display 5 divisions in amplitude.

h. CHECK—Display amplitude reduces to 2 divisions or less when the VOLTS/DIV VAR control (of the channel under test) is rotated fully CCW. Return the VOLTS/DIV VAR control to its maximum CW (detent) position.

i. Set the Calibration Generator output level and VERTICAL POSITION controls for a 2-division display vertically centered on the graticule. Use the CH 1 VAR control if necessary to obtain the correct display amplitude.

j. Set the VERTICAL POSITION control to align the top edge of the display with the top graticule line.

k. CHECK—Signal display amplitude is 1.9 to 2.1 divisions.

l. Set the VERTICAL POSITION control to align the bottom edge of the signal display with the bottom graticule line.

m. CHECK—Signal display amplitude is 1.9 to 2.1 divisions.

**Table 4-2
Accuracy Limits
CH 1, CH 2 INVERT, and Delta Volts Readouts**

VOLTS/ DIV Switch Setting CH 1 and CH 2	Stand- ard Ampli- tude Input Level	Vertical Deflection Accuracy (± 2% (in divisions))	Delta Volts Readout Accuracy (limits) 1.25% +.03 div	Limits of Trigger LEVEL Readout			
				DC Coupling		NOISE REJ Coupling	
				+ Peak	- Peak	+ Peak	- Peak
2 mV	10 mV	4.90 to 5.10	9.81 mV to 10.20 mV	8.0 mV to 12.0 mV	+1.7 mV to -1.7 mV		
5 mV	20 mV	3.92 to 4.08	19.6 mV to 20.4 mV	16.8 mV to 23.2 mV	+2.6 mV to -2.6 mV		
10 mV	50 mV	4.90 to 5.10	49.0 mV to 50.9 mV	44 mV to 56 mV	+4.5 mV to -4.5 mV		
20 mV	0.1 V	4.90 to 5.10	98.1 mV to 102.0 mV	89 mV to 111 mV	+8.0 mV to -8.0 mV		
50 mV	0.2 V	3.92 to 4.08	196 mV to 204 mV	178 mV to 222 mV	+16 mV to -16 mV	148 mV to 252 mV	+46 mV to -46 mV
100 mV	0.5 V	4.90 to 5.10	490 mV to 509 mV	0.450 V to 0.550 V	+0.035 V -0.035 V		
200 mV	1.0 V	4.90 to 5.10	0.981 V to 1.020 V	0.90 V to 1.10 V	+0.07 V to -0.07 V		
500 mV	2.0 V	3.92 to 4.08	1.96 V to 2.04 V	1.78 V 2.22 V	0.16 V to -0.16 V		
1.0 V	5.0 V	4.90 to 5.10	4.90 V to 5.09 V	4.50 V to 5.50 V	+0.35 V to -0.35 V		
2.0 V	10.0 V	4.90 to 5.10	9.81 V to 10.2 V	9.0 V to 11.0 V	+0.7 V to -0.7 V		
5.0 V	20.0 V	3.92 to 4.08	19.6 V to 20.4 V	17.8 V to 22.2 V	+1.6 V to -1.6 V		

Performance Check—2445A/2455A Service

- n. Set the CH 1 and CH 2 Input Coupling to 50 Ω DC.
- o. Connect the Calibration Generator to the CH 1 OR X input connector via a 50 Ω BNC cable. Do not use a termination.
- p. Check CH 1 and CH 2 VOLTS/DIV 50 Ω Coupling accuracy as follows:
1. Set VOLTS/DIV control to the first position listed in Table 4-3.
 2. Set the Calibration Generator STD AMPLITUDE output level to the corresponding Standard Amplitude Input Level in Table 4-3.
 3. Use the VERTICAL POSITION control to set the bottom of the signal 2 divisions below graticule center.
 4. CHECK—Vertical Deflection Accuracy (measured against the graticule) is within the limits listed in Table 4-3.
 5. Change the VOLTS/DIV to the next position listed in Table 4-3.
 6. Set the Calibration Generator to the corresponding signal amplitude setting.
 7. Repeat subparts 3 through 6 of part p for each VOLTS/DIV setting listed in Table 4-3.
 8. Set CH 1 and CH 2 Input Coupling to 1 M Ω DC.
- q. Move the test signal to CH 2 and set the VERTICAL MODE controls to display CH 2.
- r. Return the CH 1 VOLTS/DIV VAR control to the calibrated detent position.
- s. Repeat parts e through p for CH 2.
- t. Return the CH 2 VOLTS/DIV VAR control to the calibrated detent position.
- u. Rotate the Δ REF OR DLY control CCW until the cursor stops moving.
- v. CHECK—Cursor is aligned with the bottom graticule line within ± 0.2 division.
- w. Rotate the Δ control CW until the cursor stops moving.
- x. CHECK—Cursor is aligned with the top graticule line within ± 0.2 division. Push ΔV to turn off cursors.
- y. Turn the INVERT function on, and obtain a 5-division signal as explained in part g.
- ZZ. VERIFY—A down-arrow symbol appears to the left of the CH 2 VOLTS/DIV readout.
- aa. CHECK—Display amplitude is between 4.9 divisions and 5.1 divisions in amplitude (5 divisions $\pm 2\%$). Turn the INVERT function off when finished.
- bb. Connect a 5 V standard-amplitude signal from the Calibration Generator to the CH 1 OR X and CH 2 input connectors via a 50 Ω BNC cable and a Dual-Input Coupler.
- cc. Set:

VOLTS/DIV

CH 1 and CH 2	2 V
---------------	-----

VERTICAL MODE

CH 1 and CH 2	Off
ADD	On
VAR	In Detent

dd. CHECK—Vertical deflection amplitude is 4.9 to 5.1 divisions.

ee. VERIFY—A + (plus) symbol appears to the left of the CH 2 VOLTS/DIV readout.

ff. CHECK—Signal amplitude reduces to 0.2 division or less when CH 2 INVERT is on.

Performance Check—2445A/2455A Service

**Table 4-3
Accuracy Limits
CH 1 and CH 2 VOLTS/DIV 50 Ω Coupling**

VOLTS/ DIV Setting CH 1 and CH 2	Stand- ard Ampli- tude Input Level	Vertical Deflection Accuracy ± 3% in Divisions
2 mV	20 mV	4.85 to 5.15
5 mV	50 mV	4.85 to 5.15
10 mV	0.1 V	4.85 to 5.15
20 mV	0.2 V	4.85 to 5.15
50 mV	0.5 V	4.85 to 5.15
100 mV	1.0 V	4.85 to 5.15
200 mV	2.0 V	4.85 to 5.15
500 mV	5.0 V	4.85 to 5.15
1.0 V	10.0 V	4.85 to 5.15
2.0 V ^a		
5.0 V ^a		

^aNot checked. Attempting to check would exceed Maximum Input Voltage.

gg. Set:

VERTICAL MODE

CH 3	On
CH 1, CH 2, CH 4, ADD, and INVERT	Off

hh. Move the Dual-Input Coupler to the CH 3 and CH 4 input connectors.

ii. CHECK—VOLTS/DIV and TRIGGER LEVEL Readout accuracies for both setting-input level combinations listed in Table 4-4 as in subparts 4 through 23 of part e.

jj. Set the Calibration Generator output level and VERTICAL POSITION controls for a 2-division display vertically centered on the graticule.

kk. Set the VERTICAL POSITION control to align the top edge of the display with the top graticule line.

ll. CHECK—Signal display amplitude is 1.9 to 2.1 divisions.

mm. Set the VERTICAL POSITION control to align the bottom edge of the signal display with the bottom graticule line.

nn. CHECK—Signal display amplitude is 1.9 to 2.1 divisions.

oo. Set the VERTICAL MODE buttons to disable CH 3 and display CH 4.

pp. Repeat parts ii through nn for CH 4.

qq. Disconnect the test setup.

**Table 4-4
CH 3 and CH 4 Accuracy Limits**

VOLTS/DIV Switch Setting CH 3 and CH 4	Standard Ampli- tude Signal Input Level	Vertical Deflection Accuracy (± 10% in divisions)	Trigger LEVEL Readout When Barely Triggered at the Indicated Peak	
			+ Peak	– Peak
0.1 V	0.5 V	4.50 to 5.50	0.455 V to 0.545 V	± 0.03 V
0.5 V	2.0 V	3.60 to 4.40	1.82 V to 2.18 V	± 0.12 V

4. Check Channel 2 Delay.

a. Set:

VERTICAL

CH 1 and CH 2 MODE	On
CH 3 and CH 4 MODE	Off
20 MHz BW LIMIT	Off
CH 1 and CH 2 Input Coupling	50 Ω DC
CH 1 and CH 2 VOLTS/DIV	10 mV

HORIZONTAL

A SEC/DIV	1 μ s (knob in)
-----------	---------------------

TRIGGER

SOURCE	CH 1
--------	------

b. Connect a 100 kHz, fast-rise, positive-going signal from the Calibration Generator to the CH 1 OR X and the CH 2 input connectors via a 50 Ω BNC cable, a 5X attenuator and a Dual-Input Coupler.

c. Set the output level of the Calibration Generator for an approximate 5-division, vertically-centered display for both channels.

d. Use either the CH 1 or CH 2 VAR control to match signal amplitude between both channels.

e. Set:

A SEC/DIV	10 ns (knob in)
X10 MAG	On

f. Use the Horizontal POSITION control to move the rising edges of the CH 1 and CH 2 displays to graticule center.

g. Pull the SEC/DIV knob out to activate the CH 2 DLY feature.

NOTE

If the readout displays "CH 2 DLY DISABLED" instead of "CH 2 DLY—TURN Δ " the delay matching feature has been disabled and the remainder of this subsection cannot be performed. In this case, proceed to subsection 5 below.

h. CHECK— Δ control will position the CH 2 display 0.5 division or more (500 ps) to either side of the CH 1 display.

i. Superimpose the rising edges of the pulses using the Δ control.

j. Turn X10 MAG off and push in the SEC/DIV knob.

k. Disconnect the test setup.

5. Check Vertical Bandwidth—All Channels.

a. Set:

HORIZONTAL

A SEC/DIV	50 μ s (knob in)
-----------	----------------------

TRIGGER

SOURCE	VERT
--------	------

NOTE

Select channels to set VOLTS/DIV.

VOLTS/DIV

CH 1 and CH 2	20 mV
CH 3 and CH 4	0.1 V

VAR

CH 1 and CH 2	Calibrated (in detent)
---------------	------------------------

VERTICAL MODE

CH 1	On
CH 2, CH 3, and CH 4	Off

Input Coupling

CH 1 and CH 2	50 Ω DC
---------------	----------------

b. Connect the output of the Primary Levelled Sine-Wave Generator to the CH 1 OR X input connector via a precision 50 Ω BNC cable and any combination of the 10X, 5X, or 2X Attenuators needed to reduce the signal amplitude to the level called out in the next step.

Performance Check—2445A/2455A Service

c. Set the generator output level for a 6-division display at the reference frequency, then change the generator output to 100 MHz for the 2445A or to 200 MHz for the 2455A.

d. CHECK—Signal display amplitude is 4.25 divisions or greater while sweeping the generator frequency from 100 MHz to 150 MHz for the 2445A or from 200 MHz to 250 MHz for the 2455A.

e. Set the VOLTS/DIV to 0.5 V and repeat parts c and d.

f. Set the VOLTS/DIV to 1 V and the generator output level for a 4-division display at the reference frequency, then change the generator frequency to 100 MHz for the 2445A or to 200 MHz for the 2455A.

g. CHECK—Signal display amplitude is 2.82 divisions or greater while sweeping the generator frequency from 100 MHz to 150 MHz for the 2445A or from 200 MHz to 250 MHz for the 2455A.

h. Move the signal to CH 2 OR X input connector and set the VERTICAL MODE to disable CH 1 and display CH 2.

i. CHECK—Repeat parts c through g for CH 2.

j. Set the VERTICAL MODE to display CH 3 only.

k. Attach the standard-accessory 10X probe (supplied with the instrument) to the CH 3 input connector and the probe tip to the CALIBRATOR terminal.

l. Set the SEC/DIV (knob in) to 1 ms.

m. Adjust probe compensation for the best flat top on the square-wave signal display.

n. Disconnect the probe tip from the CALIBRATOR terminal. Remove the grabber tip from the probe, unscrew and remove the plastic barrel, and connect the probe to the output of the Primary Sine-Wave Generator via a BNC female-to-BNC female and a subminiature probe-tip-to-BNC feed-through termination.

o. Set the SEC/DIV to 50 μ s (knob in).

p. Set the generator output for a 4-division display at the reference frequency, then change the generator frequency to 100 MHz for 2445A or to 200 MHz for the 2455A.

q. CHECK—Signal display amplitude is 2.82 divisions or greater while sweeping the generator frequency from 100 MHz to 150 MHz for the 2445A or from 200 MHz to 250 MHz for the 2455A.

r. Move the signal to CH 4 and set the VERTICAL MODE to display CH 4 only.

s. CHECK—Repeat parts k through q for CH 4.

t. Disconnect the test setup.

6. Check Common Mode Rejection Ratio (CMRR).

a. Set:

NOTE

Select channels to set VOLTS/DIV.

VOLTS/DIV

CH 1 and CH 2	10 mV
CH 1 and CH 2 VAR	In detent

VERTICAL

CH 1, ADD, and INVERT	On
CH 2, CH 3, and CH 4	Off

Input Coupling

CH 1 and CH 2	1 M Ω DC
---------------	-----------------

HORIZONTAL

A SEC/DIV	50 μ s (knob in)
-----------	----------------------

TRIGGER

SOURCE	CH 1
--------	------

b. Connect a reference frequency signal from the Primary Leveled Sine-Wave Generator to the CH 1 OR X and CH 2 input connectors via a 50 Ω BNC cable, a 5X attenuator, and a Dual-Input Coupler.

c. Set the generator output level for an 8-division display of the reference signal on CH 1.

d. Adjust either the CH 1 VAR control or the CH 2 VAR control for a minimum ADD display amplitude while leaving the other control in the calibrated detent (whichever provides the best CMRR).

e. Set the generator frequency to 50 MHz.

f. Set the A SEC/DIV to 20 ns.

g. CHECK—ADD display amplitude is 0.4 division or less (discount trace width).

h. Set ADD and INVERT Off and rotate the CH 1 and CH 2 VAR controls CW to their calibrated detent positions.

i. Disconnect the test setup.

7. Check Channel Isolation.

a. Set:

VERTICAL MODE

CH 1, CH 2, CH 3, and CH 4 CHOP/ALT	On ALT
---	-----------

Input Coupling

CH 1 and CH 2	50 Ω DC
---------------	----------------

VOLTS/DIV

CH 1 and CH 2	100 mV
CH 3 and CH 4	0.1 V

TRIGGER

SOURCE	CH 1
--------	------

Horizontal

A SEC/DIV	20 ns (knob in)
-----------	-----------------

b. Connect the Primary Leveled Sine-Wave Generator to the CH 1 OR X input connector via a 50 Ω BNC cable.

c. Set the generator frequency to 100 MHz and adjust the output level for an 8-division display.

d. CHECK—Amplitude of each trace other than CH 1 is 0.08 division or less (discount trace width).

e. Move the signal to the CH 2 input connector and change the TRIGGER SOURCE to CH 2.

f. CHECK—Amplitude of each trace other than CH 2 is 0.08 division or less (discount trace width).

g. Add a 50 Ω BNC termination to the BNC cable and move the signal to CH 3.

h. Set the TRIGGER SOURCE to CH 3 and adjust the generator output for a signal display amplitude of 8 divisions.

i. CHECK—Amplitude of each trace other than CH 3 is 0.16 division or less (discount trace width).

j. Move the signal to CH 4 input connector and set TRIGGER SOURCE to CH 4.

k. CHECK—Amplitude of each trace other than CH 4 is 0.16 division or less (discount trace width).

l. Connect the generator to the CH 1 OR X input connector. Remove the 50 Ω termination.

m. Set the TRIGGER SOURCE to CH 1.

n. Set the generator output frequency to 150 MHz for the 2445A or to 250 MHz for the 2455A. Set the generator output level for an 8-division display.

o. CHECK—Amplitude of each trace other than CH 1 is 0.16 division or less (discount trace width).

p. Move the signal to the CH 2 input connector and set the TRIGGER SOURCE to CH 2.

Performance Check—2445A/2455A Service

q. CHECK—Amplitude of each trace other than CH 2 is 0.16 division or less (discount trace width).

r. Disconnect the test setup.

8. Set CH 1 and CH 2 DC Balance.

NOTE

For an accurate DC Balance setting, the instrument MUST be allowed to warm up for 20 minutes before performing the following steps.

a. Press both the CH 1 and CH 2 upper Input Coupling buttons for approximately 1 second, then release them.

b. VERIFY—DC BALANCE IN PROGRESS is in top line of readout. A flashing dot may be displayed. The display returns to normal in approximately 15 seconds.

c. VERIFY—There is less than 0.2 division + 0.5 mV vertical trace shift between adjacent settings of the CH 1 and CH 2 VOLTS/DIV as they are rotated through each of their positions.

d. VERIFY—There is less than 0.2 division vertical trace shift between the CH 3 and CH 4 VOLTS/DIV settings.

e. VERIFY—There is less than 1.0 division vertical trace shift as the CH 1 and CH 2 VOLTS/DIV VAR controls are rotated fully CCW.

f. VERIFY—There is less than 0.5 division vertical trace shift when the INVERT button is pressed.

g. Return the VERTICAL VAR controls to their detent positions and turn the CH 2 INVERT function off.

9. Check CH 2 SIGNAL OUT and Cascaded Operation.

a. Set:

NOTE

Temporarily select CH 2 to set CH 2 VOLTS/DIV.

VERTICAL

CH 1	On
CH 2, CH 3, and CH 4	Off
20 MHz BW LIMIT	On

VOLTS/DIV

CH 1 and CH 2	2 mV
---------------	------

Input Coupling

CH 1 and CH 2	1 MΩ DC
---------------	---------

HORIZONTAL

A SEC/DIV	200 μs (knob in)
-----------	------------------

TRIGGER

MODE	AUTO LVL
SOURCE	VERT
COUPLING	HF REJ

b. Connect a 1 kHz, 1 mV standard-amplitude signal from the Calibration Generator to the CH 2 input connector via a 50-Ω BNC cable.

c. Connect the CH 2 signal from the rear-panel CH 2 SIGNAL OUT connector to the CH 1 OR X input connector via a precision 50-Ω BNC cable.

d. CHECK—Display amplitude is 4.5 to 5.5 divisions (discount trace width).

e. Set CH 2 Input Coupling to GND and align the CH 1 trace with the center graticule line.

f. CHECK—Trace noise is 1.2 divisions peak to peak or less.

g. Set CH 1 Input Coupling to GND and align the trace with the center graticule line.

h. Return CH 1 Input Coupling to 1 MΩ DC.

i. Set the CH 1 VOLTS/DIV to 10 mV.

j. CHECK—Trace is within 2 divisions of the ground reference set above (discount trace width).

k. Disconnect the test setup.

10. Check BW Limit Operation.

a. Set:

VERTICAL

CH 1	Off
CH 2	On
BW LIMIT	On
CH 2 VOLTS/DIV	10 mV
CH 3 Input Coupling	50 Ω

HORIZONTAL

A SEC/DIV	50 μ s (knob in)
-----------	----------------------

b. Connect the Primary Leveled Sine-Wave Generator output to the CH 2 input connector via a precision 50 Ω BNC cable.

c. Set the generator frequency to 50 kHz and adjust the output level for a 6-division display on the CRT.

d. Gradually increase the generator output frequency until the display amplitude decreases to 4.24 divisions.

e. CHECK—Generator frequency is between 13 MHz to 24 MHz.

f. Turn BW LIMIT off.

g. Disconnect the test setup.

TRIGGERING

Equipment Required (see Table 4-1)

Primary Leveled Sine-Wave Generator (Item 2)	50 Ω BNC Cable (4 required) (Item 10)
Secondary Leveled Sine-Wave Generator (Item 4)	Dual-Input Coupler (Item 11)
Function Generator (Item 5)	50 Ω BNC Termination (2 required) (Item 12)
10X Probe (supplied with 2445A or 2455A) (Item 7)	Adapter (Item 25)
T Connector (2 required) (Item 8)	Adapter (Item 26) (2 Required)
Precision 50 Ω BNC Cable (Item 9)	

INITIAL CONTROL SETTINGS

Control settings not listed do not affect the procedure.

a. Set:

NOTE

Select channels to set VOLTS/DIV.

VOLTS/DIV

CH 1	100mV
CH 2	500mV
CH 1 and CH 2 VAR	In detent
CH 3 and CH 4	0.5 V

VERTICAL MODE

CH 1	On
CH 2, CH 3, CH 4, ADD and INVERT	Off
CHOP/ALT	ALT
20 MHz BW LIMIT	Off

Input Coupling

CH 1 and CH 2	1 M Ω DC
---------------	-----------------

HORIZONTAL

A SEC/DIV	2 μ s (knob in)
SEC/DIV VAR	In detent
X10 MAG	Off
TRACE SEP	Fully CW

Delta

Δt and ΔV	Off (press and release until associated readout is off)
TRACKING	Off

Trigger

HOLD OFF	B ENDS A (fully CW)
LEVEL	Midrange
SLOPE	+ (plus)
MODE	AUTO LVL
SOURCE	VERT
COUPLING	DC

1. Check A and B Triggers.

NOTE

The Trigger Level Readout Accuracies are checked in the Vertical Performance Checks.

a. Refer to Table 4-5 to determine what the A Trigger requirements are and at what frequencies various checks are made.

b. Using a 50- Ω BNC cable, connect one of the following test generators to the CH 1 input connector. Select the generator that produces the proper frequency range for the conditions being tested as called out in Tables 4-5 and 4-6. When using the leveled sine-wave generators (items 2 and 3 below), the output must be terminated into 50 Ω (either the 50- Ω input coupling or a 50- Ω termination may be used).

1. Function Generator (60 Hz, 30 kHz and 80 kHz)
2. Primary Leveled Sine-Wave Generator (50 MHz and 250 MHz)
3. Secondary Leveled Sine-Wave Generator (300 MHz and 500 MHz)

Table 4-5
CH 1 or CH 2 Triggering Conditions

Test Frequency	Minimum Vertical Display Levels at Which Triggering Should Occur				
	TRIGGER COUPLING				
	DC	NOISE REJ	HF REJ	LF REF	AC
60 Hz	a	a	a	No Trigger, Freeruns	0.35 Div
30 kHz	a	a	0.5 Div	a	a
80 kHz	a	a	a	0.5 Div	a
50 MHz	0.35 Div	1.2 Div	No Trigger, Freeruns at 1.2 Div	0.5 Div	0.35 Div
250 MHz 2445A only	1.5 Div	4.5 Div	No Trigger, Freeruns at 3.0 Div	1.5 Div	1.5 Div
300 MHz 2445A only	1.0 Div	3.0 Div	No Trigger, Freeruns at 3.0 Div	1.0 Div	1.0 Div
500 MHz 2455A only	1.5 Div	4.5 Div	a	1.5 Div	1.5 Div

NOTE

To obtain signal amplitudes less than 1 division, first set the signal for either 4, 5, or 10 times the specified amplitude; then reduce the amplitude by a factor of 4, 5, or 10 by increasing the VOLTS/DIV settings as necessary.

c. For each combination listed in the table, set the generator Test Frequency and the oscilloscope TRIGGER COUPLING as indicated, performing the following steps to verify the Triggering levels in each setup.

d. Set the VOLTS/DIV and the generator output level to obtain the test signal amplitude indicated for the particular combination being tested. When checking channel 1 and channel 2 500 MHz triggering, also adjust the VOLTS/DIV VAR for the correct input level.

e. Set the A SEC/DIV and the X10 MAG to obtain a well-defined display of the test signal.

NOTE

Normally, unless trigger sensitivity is very close to the specified limits, it is sufficient to check each of the indicated frequency-coupling combinations listed in the table in Channel 1 only; checks for Channels 2, 3 and 4 need only be done in DC COUPLING (to verify signal path).

f. CHECK—For a stably triggered display (unless otherwise indicated) for each of the Test Frequency-TRIGGER COUPLING combinations listed in Table 4-5. When testing the 150-MHz 2445A or 250-MHz 2455A triggering, check that trigger jitter is < 100 ps (0.2 division at 5 ns/div with X10 MAG), with 5 divisions of signal and TRIGGER LEVEL adjusted for minimum jitter.

*Not necessary to check.

g. Press the ADD button to select the function and press the CH 1 button to turn off the CH 1 display.

h. Repeat the DC TRIGGER COUPLING tests of Table 4-5 while in the ADD mode, adding 0.5 DIV to the 2455A 300- and 500-MHz amplitudes and adding 0.5 DIV to the 2445A 150- and 250-MHz amplitudes.

i. Move the signal to the CH 2 input connector and repeat step h for CH 2.

j. Press the CH 2 button to select the channel and press the ADD button to turn off the ADD display.

Performance Check—2445A/2455A Service

k. Repeat the DC TRIGGER COUPLING tests of Table 4-5 while in CH 2 mode.

l. If trigger sensitivity is close to the specified limits given in steps c through k above, test all of the frequency-coupling combinations given in Table 4-5 for CH 2.

m. Move the test signal to CH 3 and CH 4 in turn and repeat parts c through f using Table 4-6.

**Table 4-6
CH 3 or CH 4 Triggering Conditions**

Test Frequency	Minimum Vertical Display Levels at Which Triggering Should Occur				
	TRIGGER COUPLING				
	DC	NOISE	HF REJ	LF REF	AC
60 Hz	a	a	a	No Trigger, Freeruns	0.18 Div
30 kHz	a	a	0.25 Div	a	a
80 kHz	a	a	a	0.25 Div	a
50 MHz	0.18 Div	0.6 Div	No Trigger, Freeruns at 0.6 Div	0.18 Div	0.18 Div
300 MHz	0.5 Div	1.5 Div	No Trigger, Freeruns at 1.5 Div	0.5 Div	0.5 Div
500 MHz	0.75 Div	2.25 Div	a	0.75 Div	0.75 div

*Not necessary to check.

n. Set:

TRIGGER

MODE AUTO
LEVEL Fully clockwise

o. Pull the SEC/DIV knob out and set the B SEC/DIV 1 setting (CW) faster than the A SEC/DIV setting, then push the SEC/DIV knob back in.

NOTE

On CTT instruments, rotate the Δ REF OR DLY POS control for the specified delay. As the control is rotated, the readout delay value will be followed by the word "SET". This value shows the approximate delay. A few seconds after control movement has stopped, the word "SET" will disappear and the readout delay value as measured by the CTT will appear. This is normal operation and not cause for concern.

p. Verify that the CRT readout displays DLY and not Δt . If Δt is displayed, press the Δt button in and release it to select the DLY function. When DLY is displayed, rotate the Δ REF OR DLY POS control CCW until the readout display indicates zero delay. (The display will indicate DLY?, which is normal.)

q. Press the A/B TRIG button to select the B TRIGGER.

r. Set B TRIGGER MODE to TRIG AFT DLY and adjust TRIGGER LEVEL for a stable signal display.

s. Repeat parts a through m for B TRIGGER, changing the SEC/DIV and X10 MAG as required to maintain a well-defined display.

t. Disconnect the test setup.

2. Check Composite Triggering.

a. Set:

VERTICAL

CH 1, CH 2, CH 3, and CH 4 On
ADD Off
CHOP/ALT ALT

Input Coupling

CH 1 and CH 2 1 M Ω DC

TRIGGER

A/B TRIG A
MODE NORM
SOURCE CH 1
COUPLING DC

HORIZONTAL

A SEC/DIV 10 μ s (knob in)

b. Connect the Primary Leveled Sine Wave Generator to the CH 1 and CH 2 inputs via a 50-Ω BNC cable and a Dual-Input Coupler.

c. Set the Primary Leveled Sine Wave Generator Generator for a 50-kHz, 1.35-division display for CH 1 and CH 2.

d. Connect the Primary Leveled Sine-Wave Generator to the CH 3 input connector using a 50-Ω BNC cable and a 50-Ω termination.

e. Set TRIGGER SOURCE to CH 3.

f. Set the generator output level for a 0.7-division display at the reference frequency (50 kHz).

g. Connect the Secondary Leveled Sine-Wave Generator to the CH 4 input using a BNC cable and a 50-Ω termination.

h. Set TRIGGER SOURCE to CH 4.

i. Set the generator output level for a 0.7-division display at the reference frequency.

j. Set TRIGGER SOURCE to VERT.

k. CHECK—Display will trigger as the TRIGGER LEVEL control is rotated through its range.

l. Pull the SEC/DIV knob out, rotate it to 5 μs, and push it back in.

m. Press the A/B TRIG button and set the B TRIGGER MODE to TRIG AFT DLY.

n. Set B TRIGGER SOURCE to VERT.

o. Rotate the Δ REF OR DLY POS control CCW until the delay readout indicates DLY? 0.00 μs.

p. CHECK—Display will trigger as the TRIGGER LEVEL control is rotated through its range.

q. Rotate the SEC/DIV knob back to 10 μs (knob in).

r. Disconnect the test setup.

3. Check Trigger Noise Rejection—All Channels.

a. Set:

NOTE

Select channels to set VOLTS/DIV.

VOLTS/DIV

CH 1	5 mV
CH 2	50 mV
CH 3 and CH 4	0.1 V

VERTICAL

CH 1	On
CH 2, 3, 4	Off

Input Coupling

CH 1 and CH 2	1 MΩ DC
---------------	---------

HORIZONTAL

A SEC/DIV	10 μs (knob in)
-----------	-----------------

TRIGGER

MODE	AUTO LVL
SOURCE	VERT

NOTE

On CTT Instruments, rotate the Δ REF OR DLY POS control for the specified delay. As the control is rotated, the readout delay value will be followed by the word "SET". This value shows the approximate delay. A few seconds after control movement has stopped, the word "SET" will disappear and the readout delay value as measured by the CTT will appear. This is normal operation and not cause for concern.

b. Connect the Function Generator to the CH 1 input via a 50-Ω BNC cable and a 10X attenuator.

c. Set the Function Generator output frequency and level for a 50-kHz, 4-division display.

d. Set the CH 1 VOLTS/DIV to 50 mV.

Performance Check—2445A/2455A Service

- e. Set the TRIGGER COUPLING to NOISE REJ.
- f. CHECK—Display will not trigger (freeruns).
- g. Pull the SEC/DIV knob out, rotate it to 5 μ s and push it back in.
- h. Press the A/B TRIG button to select the B TRIGGER.
- i. Set the TRIGGER MODE to B TRIG AFT DLY.
- j. Set TRIGGER COUPLING to NOISE REJ.
- k. CHECK—Display will not trigger for any setting of the LEVEL control.
- l. Rotate the SEC/DIV back to 10 μ s (knob in).
- m. Move the input signal to CH 2, CH 3, and CH 4 in turn, selecting each channel as the display source. Repeat parts f through k for each channel.

4. Check Slope Selection and Verify Line Trigger.

a. Set:

VERTICAL

CH 1 VOLTS/DIV	5 V
CH 1 Input Coupling	1 M Ω DC
CH 1	On
CH 2, 3, 4	Off

HORIZONTAL

A SEC/DIV	2 ms (knob in)
X10 MAG	Off

TRIGGER

MODE	AUTO
SOURCE	LINE
COUPLING	AC



In the next part, DO NOT connect the probe ground lead to the ac power source.

- b. Attach the 10X probe to the CH 1 OR X input connector and connect the probe tip to the ac power source.
- c. CHECK—Display can be triggered in both the + (plus) and - (minus) positions of the SLOPE switch using the TRIGGER LEVEL control and that the displayed slope agrees with the selected slope.
- d. CHECK—Display phase shifts slightly as the TRIGGER COUPLING is changed from AC to DC.
- e. Disconnect the test setup.

HORIZONTAL

Equipment Required (see Table 4-1)

Primary Leveled Sine-Wave Generator (Item 2)

Precision 50- Ω BNC Cable (Item 9)

Calibration Generator (Item 3)

Dual Input Coupler (Item 11)

Time-Mark Generator (Item 6)

INITIAL CONTROL SETTINGS.

Control settings not listed do not affect the procedure.

a. Set:

NOTE

Select channels to set VOLTS/DIV.

VERTICAL

CH 1 and CH 2	
VOLTS/DIV	0.5 V
CH 1 VAR	In detent
CH 3 and CH 4	
VOLTS/DIV	0.1 V
CH 1	On
CH 2, CH 3, CH 4,	
ADD, and INVERT	Off
CHOP/ALT	ALT
20 MHz BW LIMIT	Off
CH 1 and CH 2	
Input Coupling	50 Ω DC

HORIZONTAL

A SEC/DIV	200 ns (knob in)
SEC/DIV VAR	In detent
X10 MAG	Off
TRACE SEP	Fully CW

Delta

ΔV and Δt	Off (press and release until associated readout is off)
TRACKING	Off

TRIGGER

HOLDOFF	B ENDS A
LEVEL	Midrange
SLOPE	+ (plus)
MODE	AUTO LVL
SOURCE	VERT
COUPLING	DC

1. Check Horizontal Display Modes (A, A INTEN, ALT, and B).

a. Use a 50- Ω BNC cable to connect 200 ns time markers from the Time-Mark Generator to the CH 1 OR X input connector.

b. Adjust the TRIGGER LEVEL control as necessary for a stable signal display.

c. Pull the SEC/DIV knob out and set the B TRIGGER MODE to RUN AFT DLY.

NOTE

On CTT instruments, rotate the Δ REF OR DLY POS control for the specified delay. As the control is rotated, the readout delay value will be followed by the word "SET". This value shows the approximate delay. A few seconds after control movement has stopped, the word "SET" will disappear and the readout delay value as measured by the CTT will appear. This is normal operation and not cause for concern.

d. Set the Δ REF OR DLY control for a DLY readout of approx 1000 ns.

e. VERIFY—An intensified zone appears on the displayed signal near graticule center. The INTENSITY control may need adjustment.

f. Rotate the Δ REF OR DLY POS control to center the intensified zone on one of the time markers near graticule center.

g. Set the B SEC/DIV to 50 ns (knob out).

Performance Check—2445A/2455A Service

h. Rotate the TRACE SEP control CCW to separate the the A and B sweep displays.

i. CHECK—The B sweep is displayed with the A sweep.

j. Push the SEC/DIV knob in.

k. CHECK—Only the B sweep is displayed.

2. Check A and B Timing, A Cursor Accuracies, and A Cursor Range.

a. Set:

HORIZONTAL

A SEC/DIV	10 ns (knob in)
TRACE SEP	Fully CW

Delta

Δt	On (press and release for Δt display)
------------	---

b. Select 10 ns time markers from the Time-Mark Generator and adjust the TRIGGER LEVEL control for a stable display.

c. Use the Horizontal POSITION control to align the 2nd time marker with the 2nd vertical graticule line (2nd from the left edge of the display).

NOTE

The 2 ns and the 5 ns time markers are sinusoidal. Use either the rising or falling zero-crossings as alignment points.

d. Align the Δ REF cursor with the 2nd time marker and align the Δ cursor with the 10th time marker.

e. CHECK—The A Sweep timing and cursor readout accuracies are within limits given in Tables 4-7 and 4-8.

NOTE

If the 2nd and 10th time markers are within 0.06 division of the 2nd and 10th vertical graticule lines for unmagnified sweeps and within 0.1 division for magnified sweeps, the sweep timing accuracy is conservatively within limits. When the timing accuracy is checked at each sweep speed, note any SEC/DIV setting at which the timing error exceeds the 0.06-division limit. Check these sweep speeds against the major-division time-interval limits given in Table 4-8.

NOTE

For SEC/DIV setting of 10 ns, the time-marker period is greater than 1 division when the sweep is magnified. At 1 ns per division (SEC/DIV setting of 10 ns with X10 MAG), input the signal through a dual input coupler to CH1 and CH2. Select CH1, CH2, and CH2 INVERT. Set the CH 1 and CH 2 VOLTS/DIV settings for a 6 division signal. Center the waveforms. Check for 4 cycles between the 2nd and 10th vertical graticule lines (within 0.1 division) at the intersections of the waveforms.

f. Repeat parts c, d and e for each A SEC/DIV-time marker combination given in Table 4-7 for both unmagnified and magnified sweeps.

Table 4-7
Settings for A and B Timing Accuracy Checks
and A and B Cursor Accuracy Limits

SEC/ DIV Setting	Unmagnified		X10	
	Time Markers	Limits of Δt Cursor Readout	Time Markers	Limits of Δt Cursor Readout
10 ns	10 ns	79.30 ns to 80.70 ns	2 ns 2 Div/cycle	7.89 ns to 8.11 ns (4 cycles)
20 ns	20 ns	158.60 ns to 161.40 ns	2 ns	15.78 ns to 16.22 ns
50 ns	50 ns	396.5 ns to 403.5 ns	5 ns	39.45 ns to 40.55 ns
100 ns	0.1 μ s	793.0 ns to 807.0 μ s	10 ns	78.90 ns to 81.10 ns
200 ns	0.2 μ s	1586.0 ns to 1614.0 ns	20 ns	157.80 ns to 162.20 ns
500 ns	0.5 μ s	3965 ns to 4035 ns	50 ns	394.5 ns to 405.5 ns
1 μ s	1 μ s	7.930 μ s to 8.070 μ s	0.1 μ s	789.0 ns to 811.0 ns
2 μ s	2 μ s	15.860 μ s to 16.140 μ s	0.2 μ s	1578.0 ns to 1622.0 ns
5 μ s	5 μ s	39.65 μ s to 40.35 μ s	0.5 μ s	3945 ns to 4055 ns
10 μ s	10 μ s	79.30 μ s to 80.70 μ s	1 μ s	7.890 μ s to 8.110 μ s
20 μ s	20 μ s	158.60 μ s to 161.40 μ s	2 μ s	15.780 μ s to 16.220 μ s
50 μ s	50 μ s	396.5 μ s to 403.5 μ s	5 μ s	39.45 μ s to 40.55 μ s
100 μ s	100 μ s	793.0 μ s to 807.0 μ s	10 μ s	78.90 μ s to 81.10 μ s
200 μ s	200 μ s	1586.0 μ s to 1614.0 μ s	20 μ s	157.80 μ s to 162.20 μ s
500 μ s	500 μ s	3965 μ s to 4035 μ s	50 μ s	394.5 μ s to 405.5 μ s
1 ms	1 ms	7.930 ms to 8.070 ms	100 μ s	789.0 μ s to 811.0 μ s
2 ms	2 ms	15.860 ms to 16.140 ms	200 μ s	1578.0 μ s to 1622.0 μ s
5 ms	5 ms	39.65 ms to 40.35 ms	500 μ s	3945 μ s to 4055 μ s
10 ms	10 ms	79.30 ms to 80.70 ms	1 ms	7.890 ms to 8.110 ms
20 ms	20 ms	158.60 ms to 161.40 ms	2 ms	15.780 ms to 16.220 ms
50 ms	50 ms	396.5 ms to 403.5 ms	5 ms	39.45 ms to 40.55 ms
A SEC/DIV ONLY	(B Sweep does not have these sweep speeds)			
100 ms	0.1 s	793.0 ms to 807.0 ms	10 ms	78.90 ms to 81.10 ms
200 ms	0.2 s	1578.0 ms to 1622.0 ms	20 ms	157.00 ms to 163.00 ms
500 ms	0.5 s	3945 ms to 4055 ms	50 ms	392.5 ms to 407.5 ms

Table 4-8
Horizontal Timing Accuracy Checked Against the Graticule

	Over Any									
	1 Div	2 Div	3 Div	4 Div	5 Div	6 Div	7 Div	8 Div	9 Div	10 Div
Time-marker Accuracy (X10 MAG Off)	± 0.07 Div	± 0.07 Div	± 0.08 Div	± 0.09 Div	± 0.10 Div	± 0.10 Div	± 0.11 Div	± 0.12 Div	± 0.12 Div	± 0.13 Div
Time-marker Accuracy (X10 MAG On)	± 0.07 Div	± 0.08 Div	± 0.1 Div	± 0.11 Div	± 0.12 Div	± 0.13 Div	± 0.14 Div	± 0.16 Div	± 0.17 Div	± 0.18 Div
As Measured Against These Time-Marker Pairs (X10 MAG Off Only)	1-2	1-3	1-4	1-5	1-6	1-7	1-8	1-9	1-10	1-11
	2-3	2-4	2-5	2-6	2-7	2-8	2-9	2-10	2-11	
	3-4	3-5	3-6	3-7	3-8	3-9	3-10	3-11		
	4-5	4-6	4-7	4-8	4-9	4-10	4-11			
	5-6	5-7	5-8	5-9	5-10	5-11				
	6-7	6-8	6-9	6-10	6-11					
	7-8	7-9	7-10	7-11						
	8-9	8-10	8-11							
	9-10	9-11								
	10-11									

g. Rotate the Δ REF OR DLY POS control CCW until the cursor stops moving.

h. CHECK—Δ REF cursor aligns with the 1st graticule line within 0.2 division.

i. Rotate the Δ control CW until the cursor stops moving.

j. CHECK—Δ cursor aligns with the 11th graticule line within 0.2 division.

k. Set the A SEC/DIV to 10 ns.

l. Rotate the Δ REF OR DLY and the Δ controls to precisely superimpose the cursors near the 2nd graticule line.

m. CHECK—Δt readout indicates a difference of 0.30 ns or less.

n. Rotate the Δ REF OR DLY and the Δ controls to precisely superimpose the cursors near the 10th graticule line.

o. CHECK—Δt readout indicates a difference of 0.30 ns or less.

p. Set:

HORIZONTAL

A SEC/DIV 20 ns
 B SEC/DIV 10 ns (knob in)
 X10 MAG Off

TRIGGER

B TRIGGER MODE RUN AFT DLY

Delta

Δt On (Push Δt for Δt cursors)

NOTE

To easily maintain the A SWP and B SWP difference while checking timing and cursor accuracy, use the following method:

1. Set TRACK/INDEP off. Pull B SEC/DIV knob out.
2. Push and hold the TRACK/INDEP button while pushing the B SEC/DIV knob in. This will lock the A and B sweeps together with A sweep one speed slower than B sweep.
3. Press Δt button to obtain Δt cursors.

q. CHECK—The B sweep timing and cursor accuracy as in parts b through f, making sure that the A SEC/DIV is set slower than the B SEC/DIV.

3. Check Delta Time Accuracy using the Delayed Sweep.

a. Set:

HORIZONTAL

A SEC/DIV	20 ns
B SEC/DIV	10 ns (knob out)
X10 MAG	On
TRACK/INDEP	Off

Delta

Δt	Off (DLY readout)
------------	-------------------

TRIGGER

MODE	AUTO LVL
SOURCE	VERT
COUPLING	DC
SLOPE	+ (plus)
LEVEL	As required for a stable display
B TRIG MODE	RUN AFT DLY

NOTE

Certain time marks from the TG 501 (and other Time-Mark Generators) will vary in width and may be displaced in time. This will happen in a repeatable sequence and is caused by the loading and interaction of the 2, 5, and 10 dividers. This is most noticeable with 10 ns, 20 ns, and 50 ns markers. The following procedure will use the above markers to set up the proper references but the 5 ns markers will be used to make the actual measurement. Close inspection of apparent jitter or mistrigger of the time marks will show the trigger point to be stable with the apparent jitter to be variable with unique combinations of trigger holdoff and sweep speed. This is normal behavior with this type of signal and is not an instrument defect.

It is not necessary to count the number of marks given in the tables. Switching to 10 ns, 20 ns, or 50 ns markers as required and then to 5 ns will show the proper 5 ns mark to be used.

For CTT instruments, use the following setup of the CTT while performing the Delta Time performance check.

1. Push the upper TRIGGER MODE button for MENU.
2. Adjust the Δ REF OR DLY POS or Δ control to underline **COUNT** in the CTT MENU.
3. Push the upper TRIGGER MODE button.
4. If the instrument contains Option 09, adjust the Δ REF OR DLY POS control to underline **MODE**.
5. Adjust the Δ control to underline **PERIOD**.
6. If the instrument contains Option 09, adjust the Δ REF OR DLY POS control to underline **EVT**.
7. If the instrument contains Option 09, adjust the Δ control to underline **A**.

Performance Check—2445A/2455A Service

8. Push the upper TRIGGER MODE button to enable CTT period measurements.

The CTT period readout will appear on the left side of the upper line of readout. The word "SET" will appear next to the readout delay value. This denotes the indirect measurement mode of Delta Time, simulating a non-CTT scope.

b. Set the Time-Mark Generator for 20-ns markers. Adjust the Vertical VOLTS/DIV as required for a display of 3 to 6 divisions.

c. Adjust the Δ REF OR DLY POS control for a readout display of DLY 21.25 ns.

d. Adjust the Horizontal POSITION control CW until the trace stops moving, then CCW to display the leading edge of the 2nd B sweep time marker near the graticule center. This becomes the reference point for the following procedure. Set the Time-Mark Generator to 5 ns and adjust the Vertical VOLTS/DIV and Trigger LEVEL as required.

e. Press and release the Δt button to obtain the Δt display. Push in the SEC/DIV knob for B SWP only. Rotate the Δ control for a readout display of Δt -20.0 ns. If the time marks are not superimposed, adjust the Δ control to do so.

f. CHECK— Δt readout is within the limits listed in Table 4-9 for the 1st 5 ns time marker; then check that the 5th through 37th time markers are within the given limits as the Δ control is rotated CW to superimpose the time marker on the reference time marker.

NOTE

Correct time marks to superimpose on the reference marker can be easily found by noting the Delta Time Readout.

g. Set:

HORIZONTAL

A SEC/DIV 50 ns
 B SEC/DIV 10 ns (knob out)
 X10 MAG ON

Delta

Δt Off (DLY readout)

**Table 4-9
 Delta Time Display Accuracy**

Time-Marker Period and A SEC/DIV Switch Setting	B SEC/DIV Switch Setting	Marker Superimposed using the Δ (Delta) Control	Delta Time Readout Accuracy Limits
20 ns	1 ns ^a	1st	-19.25 ns to -20.25 ns
		5th	-0.20 ns to 0.20 ns
		9th	19.25 ns to 20.25 ns
		13th	39.70 ns to 40.30 ns
		17th	59.60 ns to 60.40 ns
		21st	79.55 ns to 80.45 ns
		25th	99.50 ns to 100.5 ns
		29th	119.45 ns to 120.55 ns
		33rd	139.40 ns to 140.60 ns
		37th	159.30 ns to 160.70 ns
50 ns	1 ns ^a	1st	-49.3 ns to -50.7 ns
		21st	49.3 ns to 50.7 ns
		91st	398.3 ns to 401.7 ns

^a5 ns with X10 MAG on (button in).

h. Set the Time-Mark Generator for 50-ns time markers and adjust the Δ REF OR DLY POS control for a readout display of DLY 53.2 ns.

i. Position the leading edge of the 1st B-sweep time marker near graticule center using the Horizontal POSITION control. Set the Time-Mark Generator to 5 ns and adjust the Vertical VOLTS/DIV and Trigger LEVEL as required.

j. Press and release the Δt button to obtain a Δt display. Push in the SEC/DIV knob for B sweep only. Adjust the Δ control for a readout display of Δt -50.00 ns. If the time markers are not superimposed, adjust the Δ control to do so.

k. CHECK— Δt readout is within the limits listed in Table 4-9 for the 1st 5 ns time marker; then check that the 21st and 91st time markers are within the given limits as the Δ control is rotated CW to superimpose each time marker on the reference time marker.

i. Set:

Delta

TRACK/INDEP TRACK

HORIZONTAL

A SEC/DIV 100 ns
 B SEC/DIV 10 ns (knob out)
 X10 MAG On

m. Select 0.1- μ s time markers from the Time-Mark Generator.

n. Adjust the Δ and Δ REF OR DLY POS controls for a Δt readout display of 800.0 ns.

o. Adjust the Horizontal POSITION control to align the leading edge of the 2nd time marker on the A sweep with the 2nd vertical graticule line.

p. Rotate the TRACE SEP control CCW to separate the traces.

q. Adjust the Δ REF OR DLY POS control to intensify the 2nd and 10th time markers (of the A sweep) and display the leading edges of the displayed B-sweep time markers in the center area of the graticule.

r. VERIFY—The horizontal distance between the leading edges of the B-sweep time markers is within the conservative guideline listed in Table 4-10. If this guideline is met, accuracy between each marker is ensured, and the following CHECK step need not be performed.

NOTE

To easily maintain the A SWP and B SWP difference while testing Delta Time, use the following method:

1. Starting with the 1- μ s test in Table 4-10 (X10 MAG Off), turn TRACKING off.
2. Press and hold the TRACKING button, then push the SEC/DIV knob in. This will lock the sweeps together at that difference.
3. Pull the SEC/DIV knob out.

The fastest sweep speed at which the X100 difference is maintained is with an A SEC/DIV of 1 μ s and a B SEC/DIV of 10 ns, after which only the A-sweep speed will change with the SEC/DIV knob. Push TRACKING to unlock this setup.

s. CHECK—The horizontal distance between the leading edges of the B-sweep time markers is within the specified limits given in Table 4-10. The limit given is for separation between the 2nd and 10th marker; however, separation between the 2nd marker and each succeeding marker should also be checked, calculating the limits from the specification as listed at the top of the table.

t. Repeat part r (and s if necessary) for each combination of A SEC/DIV, B SEC/DIV, and X10 MAG settings listed in Table 4-10. The Δt readout should be set to indicate eight times the A SEC/DIV setting. At the slowest sweep speeds, the B SEC/DIV knob can be pushed in (in B Sweep only) to increase the display repetition rate.

**Table 4-10
 Delayed Sweep Delta Time Accuracy**

A SEC/DIV and Time Markers	B SEC/DIV as Displayed on Readout	Displayed Separation of Delayed Time Markers (for 2nd and 10th markers)	
		Conservative Guideline (divisions)	Specified Limit: (0.3% time) interval +0.1% of full scale-divisions
0.1 μ s	1 ns ^a	2.4	3.4
0.2 μ s	2 ns ^a	2.4	3.4
0.5 μ s	5 ns ^a	2.4	3.4
1 μ s	10 ns ^b	2.4	3.4
2 μ s	20 ns	2.4	3.4
5 μ s	50 ns	2.4	3.4
10 μ s	100 ns	2.4	3.4
20 μ s	200 ns	2.4	3.4
50 μ s	500 ns	2.4	3.4
0.1 ms	1 μ s	2.4	3.4
0.2 ms	2 μ s	2.4	3.4
0.5 ms	5 μ s	2.4	3.4
1 ms	10 μ s	2.4	3.4
2 ms	20 μ s	2.4	3.4
5 ms	50 μ s	2.4	3.4
10 ms	100 μ s	2.4	3.4
20 ms	200 μ s	2.4	3.4
50 ms	500 μ s	2.4	3.4
0.1 s	1 ms	2.4	3.4
0.2 s	2 ms	6.4	7.4
0.5 s	5 ms	6.4	7.4

^aX10 MAG On.

^bFor remainder of table, turn X10 MAG Off.

COUNTER/TIMER/TRIGGER CHECKS

This section contains the portion of the Option 06 (Counter/Timer/Trigger) performance check procedure that directly affects operation of the horizontal timing modes. If your instrument does not contain this option, continue with the Horizontal checks.

Test equipment listed in Table 4-1 is required to perform this procedure. To assure accurate measurements, it is important that test equipment used for making these checks meet or exceed the specifications described in Table 4-1 for CTT checks.

INITIAL CONTROL SETTINGS

Control settings not listed do not affect the procedure.

NOTE

Select channels to set VOLTS/DIV.

VERTICAL

CH 1 and CH 2	
VOLTS/DIV	500 mV
CH 1 and CH 2 VAR	In detent
CH 3 and CH 4	
VOLTS/DIV	0.1 V
CH 1	On
CH 2, CH 3, CH 4,	
ADD, and INVERT	Off
CHOP/ALT	ALT
20 MHz BW LIMIT	Off
CH 1 and CH 2	
Input Coupling	50 Ω DC

HORIZONTAL

A SEC/DIV	10 ns (knob in)
SEC/DIV VAR	In detent
X10 MAG	Off
TRACKING	Off
TRACE SEP	Fully CW

Delta

Δt and ΔV	Off (press and release until associated readout is Off)
---------------------------	---

TRIGGER

HOLDOFF	Fully CCW
A and B LEVEL	Midrange
SLOPE	+ (plus)
A MODE	AUTO LVL
SOURCE	VERT
COUPLING	DC
B MODE	RUN AFT DLY

CTT and WR Options

MENU Functions	OFF
----------------	-----

1. Check Maximum Input Frequency at Minimum Sensitivity.

a. Connect the leveled sinewave generator output via a 50- Ω cable to the CH 1 input connector.

b. Set generator to produce a 150-MHz, 4 division display.

c. Push the A/B MENU button to enter MENU mode.

d. Turn either Δ control to underline **COUNT**.

e. Push the upper TRIGGER MODE button.

f. If the instrument contains Option 09 (Word Recognizer), turn the Δ REF OR DLY POS control to underline **MODE**.

g. Turn the Δ control to underline **FREQ**.

h. If the instrument contains Option 09 (Word Recognizer), turn the Δ REF OR DLY POS control to underline **EVT**.

i. If the instrument contains Option 09 (Word Recognizer), turn the Δ control to underline event **A**.

j. Push the upper TRIGGER MODE button to enter Frequency mode.

k. Push the upper TRIGGER MODE button to reinitialize the auto-trigger level.

l. CHECK—Reading is between 149 MHz and 151 MHz and is stable.

2. Check Minimum Sensitivity at 50 MHz.

- a. Set the generator to produce a 50.0-MHz, 1.3-division display.
- b. Push the upper TRIGGER MODE button to reinitialize the auto trigger level.
- c. CHECK—Reading is between 49.9 MHz and 50.1 MHz and is stable.
- d. Disconnect the test equipment from the instrument.

3. Check Frequency Accuracy.

- a. Connect the time-mark generator output via a 50-Ω cable to the CH 1 input connector.
- b. Set the generator to produce 10-ns time markers four divisions in amplitude using CH 1 VOLTS/DIV and VAR VOLTS/DIV.
- c. Push the upper TRIGGER MODE button to reinitialize the auto-trigger level.
- d. CHECK—Reading is between 99.9995 MHz and 100.0005 MHz.

4. Check Minimum Input Frequency.

- a. Set the time-mark generator to produce 2-s time markers.
- b. Set:

CH 1 VOLTS/DIV	100 mV
A TRIGGER MODE	NORM
A SEC/DIV	50 ms (knob in)
- c. Adjust the A TRIGGER LEVEL control for a stable trigger.
- d. CHECK—Reading is between 499.9975 mHz and 500.0025 mHz.
- e. Disconnect the test equipment from the instrument.

5. Check Delay Time.

- a. Set:

CH 1 VOLTS/DIV	500 mV
CH 1 Input Coupling	GND
A SEC/DIV	20 ns (knob in)
A TRIGGER MODE	AUTO
- b. Connect the output of the time-mark generator via a 50-Ω cable to the positive trigger input of the pulse generator.
- c. Connect the output of the pulse generator via a 50-Ω cable to the CH 1 input connector.
- d. Set the time-mark generator to produce 20-ns time markers.
- e. Set the pulse generator to produce a positive 5-ns pulse when externally triggered.
- f. Adjust the CH 1 POSITION control to center the Channel 1 display.
- g. Set the CH 1 Input Coupling to 50 Ω DC.
- h. Adjust the pulse generator to produce a 5-division peak-to-peak display, centered about ground.
- i. Adjust the A TRIGGER LEVEL for a readout of 0.00 V.
- j. Pull out the SEC/DIV knob.
- k. Push the A/B MENU button.
- l. Set the B TRIGGER MODE to TRIG AFT DLY, SOURCE to VERT, COUPLING to DC, and SLOPE to +.
- m. Adjust the B TRIGGER LEVEL for a readout of 0.00 V.
- n. Turn the Δ REF OR DLY POS control counterclockwise until the intensified zone stops moving to the left.

Performance Check—2445A/2455A Service

o. CHECK—Reading is either 59.5 ns to 60.5 ns or 69.5 ns to 70.5 ns.

6. Check Delta Time Accuracy.

- a. Set the B TRIGGER MODE to MENU.
- b. Turn either Δ control to underline **RES**.
- c. Push the upper TRIGGER MODE button.
- d. Turn either Δ to underline **10 ps**.
- e. Push the upper TRIGGER MODE button.
- f. Set the A SEC/DIV to 1 μ s (knob out).
- g. Push A/B MENU to access the B TRIGGER controls.
- h. Push the lower TRIGGER MODE button to enter TRIG AFT DLY mode.
- i. Set the time-mark generator to produce 1- μ s time markers.
- j. Set the pulse generator to produce a positive 0.5- μ s pulse when externally triggered.
- k. Push and release the Δt button until the Delta Time readout appears.
- l. Turn the Δ control to intensify the rising edge of the second square wave.
- m. Turn the Δ REF OR DLY POS control to intensify the rising edge of the second square wave.
- n. CHECK—Averaged Δt reading is between + 0.00005 μ s and – 0.00005 μ s.
- o. Turn the Δ control to intensify the rising edge of the eleventh square wave.

p. CHECK—Averaged Δt reading is between 8.99990 μ s and 9.00010 μ s.

q. Set the A and B SEC/DIV to 100 μ s (knob out).

r. Set the time-mark generator to produce 0.1-ms time markers.

s. Set the pulse generator to produce a positive 50- μ s pulse when externally triggered.

t. Turn the Δ control to intensify the rising edge of the eleventh square wave.

u. Turn the Δ REF OR DLY POS control to intensify the rising edge of the second square wave.

v. CHECK—Reading is between + 899.996 μ s and + 900.004 μ s.

w. Press the upper TRIGGER MODE button to access the MENU.

x. If RES is not underlined, use the Delta controls to underline **RES**.

y. Press the upper TRIGGER MODE button.

z. Use the Delta controls to underline **AUTO**.

aa. Press the upper TRIGGER MODE button.

7. Verify Delay-By-Events.

a. Lock together the A SEC/DIV to 100 μ s (knob in).

b. Set the A TRIGGER SLOPE to – (minus).

c. Push the Δt button until the Δt display disappears.

d. Push the A/B MENU button.

e. Use either Δ control to underline **DLY/EVTS**.

- f. Push the upper TRIGGER MODE button.
- g. Use the Δ REF OR DLY POS and Δ controls to select **SWP B**, **START A**, and **DLY BY B**.
- h. Push the upper TRIGGER MODE button.
- i. Pull out the SEC/DIV knob.
- j. Use the Δ REF OR DLY POS and the Δ controls to set the number of delaying events to 1.
- k. VERIFY—That the intensified zone moves to each succeeding rising edge as the delaying event count is changed to 2, 3, 4, and 5.

8. Check Logic Trigger.

- a. Set the A and B SEC/DIV to 20 ns (knob out).
- b. Set the time-mark generator to produce 0.1- μ s time markers.
- c. Set the pulse generator to produce a positive 5-ns pulse when externally triggered.
- d. Set the B TRIGGER MODE to TRIG AFT DLY.
- e. Set the B TRIGGER SOURCE to CH 1.
- f. Set the B TRIGGER MODE to MENU.
- g. Turn either Δ control clockwise to underline **LOGIC-TRIG**.
- h. Push the upper TRIGGER MODE button.
- i. Turn the Δ control to underline **A:A·B**. (On instruments without Option 09, underline **A·B**).
- j. Push the upper TRIGGER MODE button.
- k. Push in the SEC/DIV knob.

- l. Adjust the B TRIGGER LEVEL for a readout of 0.00 V.
- m. Push the A/B MENU button to illuminate an A TRIGGER MODE indicator.
- n. Adjust the A TRIGGER LEVEL for a readout of 1.00 V.
- o. Set the CH 1 Input Coupling to GND.
- p. Turn the CH 1 POSITION control to align the trace with the center horizontal graticule line; do not readjust the CH 1 POSITION control during the remainder of this step.
- q. Set the CH 1 Input Coupling to 50 Ω DC.
- r. Set X10 MAG on.
- s. Turn the HORIZONTAL POSITION control to align the rising edge of the first displayed signal with the intersection of the second vertical graticule and the center horizontal graticule lines.
- t. Set the pulse generator to produce a 2-ns pulse when externally triggered.
- u. Increase the duration of the pulse until a stable display is obtained.
- v. CHECK—Width of the pulse measured at the center horizontal graticule line is less than 4 ns.
- w. Set X10 MAG off.
- x. Push the upper TRIGGER MODE button.
- y. Push the lower TRIGGER MODE button.
- z. Push the upper TRIGGER MODE button.
- aa. Disconnect the test equipment from the instrument.

Performance Check—2445A/2455A Service

9. Verify Trigger Delta Delay.

a. Connect the leveled sine-wave generator's output via a 50- Ω cable to the CH 1 input connector. Set the A SEC/DIV to 10 μ s. Set the Horizontal POSITION to midrange.

b. Set the generator for a 50-kHz, 6-division display.

c. Push the TRIGGER SLOPE button to illuminate the + SLOPE indicator.

d. Push the A/B MENU button to enter MENU mode.

e. Turn either Δ control to underline **COUNT**.

f. Push the upper TRIGGER MODE button.

g. If the instrument contains Option 09 (Word Recognizer), turn the Δ REF OR DLY POS control to underline **MODE**.

h. Turn the Δ control to underline **PERIOD**.

i. If the instrument contains Option 09 (Word Recognizer), turn the Δ REF OR DLY POS control to underline **EVT**.

j. If the instrument contains Option 09 (Word Recognizer), turn the Δ control to underline event **A**.

k. Push the upper TRIGGER MODE button to enter Period mode.

l. Push the upper TRIGGER MODE button to reinitialize the auto-trigger level.

m. Turn the SEC/DIV to 5 μ s.

n. Pull out the SEC/DIV knob.

o. Push the A/B MENU button for B Trigger MODE. Set B Trigger MODE to RUN AFT DLY.

p. Adjust the Δ REF or DLY POS for a delay of 5.00 μ s.

q. Push the lower TRIGGER MODE button once.

r. Push the SLOPE button to select + SLOPE if necessary.

s. Push lower TRIGGER MODE button twice to select TRIG Δ DLY.

t. Push the TRIGGER SLOPE button to illuminate the – SLOPE indicator.

u. Adjust the Δ control for a delta time reading of approximately 0.00 μ s. The word "SET" will appear while making the adjustment.

v. VERIFY—There are two intensified zones on the displayed waveform.

w. VERIFY—That the intensified zone moves on the falling edge of the waveform while adjusting the TRIGGER LEVEL control.

x. Push the lower TRIGGER MODE button to select TRIG AFT DLY.

y. VERIFY—That the intensified zone moves on the rising edge of the waveform while adjusting the TRIGGER LEVEL control.

z. Disconnect the test equipment from the instrument.

HORIZONTAL (cont)

4. Check Delay Jitter.

a. Set:

TRACKING	Off
A SEC/DIV	1 ms
B SEC/DIV	500 ns (knob out)
B TRIG	RUN AFT DLY

b. Connect Time-Mark Generator to the CH 1 or X input. Select 1-ms time markers from the Time-Mark Generator.

c. Align the intensified zones with the 10th time marker using the Δ REF OR DLY POS and Δ controls. Superimpose the zones to obtain a Δt readout display of 0.000 ms.

d. Push in the SEC/DIV knob and adjust TRACE SEP to separate the traces.

e. CHECK—For 0.8 divisions or less of horizontal jitter on the rising edge of both time markers.

5. Check SEC/DIV VAR Range and Accuracy.

a. Set:

A SEC/DIV	10 ms (knob in)
SEC/DIV VAR	In detent
Δt	Off (press and release to eliminate Δt readout)
HOLDOFF	B ENDS A

b. Select 10-ms time markers from the Time-Mark Generator and adjust the Time-Mark Generator variable timing control for exactly 1 time marker per division. Note the variable timing % error on the Time-Mark Generator.

c. Adjust the SEC/DIV VAR control for a sweep-speed readout (on bottom line of readout) of 20 ms and adjust the Time-Mark Generator variable timing control for exactly 2 time markers per division.

d. CHECK—The Time-Mark Generator variable timing % of error has changed 2% or less from the reading noted in part b.

e. Adjust the SEC/DIV VAR control fully CCW.

f. CHECK—Sweep speed readout displays 30.0 ms.

g. Set the Time-Mark Generator variable timing control for exactly 3 time markers per division.

h. CHECK—The Time-Mark Generator variable timing % of error has changed 2% or less from the reading noted in part b. Set SEC/DIV VAR to detent.

i. Set:

SEC/DIV VAR	CW (in detent)
A SEC/DIV	50 ms
B SEC/DIV	10 ms (knob in)
Δt	Off (DLY readout)
B TRIGGER MODE	RUN AFT DLY
Δ REF OR DLY POS	Zero delay

NOTE

On CTT instruments, rotate the Δ REF OR DLY POS control for the specified delay. As the control is rotated, the readout delay value will be followed by the word "SET", denoting the indirect measurement mode. A few seconds after control movement has stopped, the word "SET" will disappear and the readout will display a direct measurement from the CTT.

j. Repeat parts b through h for the B Sweep.

k. Disconnect the test setup.

Performance Check—2445A/2455A Service

6. Check X-Axis Gain.

a. Set:

NOTE

Select channels to set VOLTS/DIV.

VERTICAL

CH 1 and CH 2 VOLTS/DIV	10 mV
CH 2	On
CH 1, CH 3, CH 4, ADD, and BW LIMIT	Off
CH 1 Input Coupling	1 M Ω DC
CH 2 Input Coupling	1 M Ω GND

HORIZONTAL

SEC/DIV VAR	CW (in detent)
SEC/DIV	X-Y (knob in)

b. Connect a 50-mV standard-amplitude signal from the Calibration Generator to the CH 1 OR X input connector via a 50- Ω BNC cable.

c. CHECK—Signal display amplitude is 4.9 to 5.1 horizontal divisions.

d. Disconnect the test setup.

7. Check X-Axis Bandwidth.

a. Set the CH 1 Input Coupling to 50 Ω DC.

b. Connect a 50-kHz signal from the Primary Leveled Sine-Wave Generator to the CH 1 OR X input connector via a precision 50- Ω BNC cable.

c. Set the generator output for a 6-division horizontal display.

d. Change the generator frequency to 3 MHz.

e. CHECK—Signal display is greater than 4.2 horizontal divisions.

8. Check X-Y Phase Differential.

a. Set the Primary Leveled Sine-Wave Generator for a 1-MHz, 6-division horizontal display.

b. Set the CH 2 VERTICAL MODE off. CH 1 displays automatically.

c. Use the CH 1 VERTICAL POSITION control to vertically center the display on the graticule.

d. CHECK—Ellipse opening is 0.1 division or less, measured horizontally.

e. Set the CH 2 VERTICAL MODE on.

f. Set the generator for a 2-MHz, 6-division horizontal display.

g. Set the CH 2 VERTICAL MODE off.

h. CHECK—Ellipse opening is 0.3 division or less, measured horizontally.

i. Set the CH 2 VERTICAL MODE on.

9. Check X-Axis Low-Frequency Linearity.

a. Set the Primary Leveled Sine-Wave Generator and the CH 1 POSITION control for a 50-kHz, 2-division horizontal display centered on the graticule.

b. Use the CH 1 POSITION control to align the left edge of the signal with the left side vertical graticule line.

c. CHECK—Signal display is 1.8 to 2.2 divisions, measured horizontally.

d. Use the CH 1 POSITION control to position the right edge of the signal on the right side vertical graticule line.

e. CHECK—Signal display is 1.8 to 2.2 divisions, measured horizontally.

f. Disconnect the test setup.

CALIBRATOR, EXTERNAL Z-AXIS AND GATE OUTPUTS

Equipment Required (see Table 4-1)

Calibration Generator (Item 3)	50 Ω BNC T-Connector (Item 8)
Time-Mark Generator (Item 6)	50 Ω BNC Cables (2 required) (Item 10)
Oscilloscope with 10X Probe (Item 7)	

INITIAL CONTROL SETTINGS

Control settings not listed do not affect the procedure.

a. Set:

VERTICAL

CH 1 and CH 2	On
CH 3, CH 4, ADD, and INVERT	Off
CHOP/ALT	CHOP
20 MHz BW LIMIT	Off
CH 1 VOLTS/DIV	10 mV
CH 2 VOLTS/DIV	500 mV
CH 1 and CH 2 VAR	In detent
CH 1 Input Coupling	1 M Ω DC
CH 2 Input Coupling	50 Ω DC

HORIZONTAL

A SEC/DIV	1 ms (knob in)
SEC/DIV VAR	In detent
X10 MAG	Off

Delta

ΔV and Δt	Off (press and release until associated readout is Off)
---------------------------	---

TRIGGER

HOLDOFF LEVEL	B ENDS A (fully CW)
SLOPE	Midrange
MODE	+ (plus)
SOURCE	AUTO LVL
COUPLING	CH 1
	DC

1. Check CALIBRATOR Repetition Rate.

NOTE

Refer to the Adjustment Procedure to check the accuracy of the CALIBRATOR output levels.

a. Connect a 10X probe from the CALIBRATOR terminal to the CH 1 OR X input connector.

b. Connect 1-ms time markers from the Time-Mark Generator to the CH 2 input connector via a 50- Ω BNC cable.

c. Adjust the CH 2 VOLTS/DIV for several divisions of marker display.

d. CHECK—Horizontal drift for any time marker is 1 division or less per second (10 seconds or more for 1 marker to drift 10 horizontal divisions).

e. Set the CH 2 VERTICAL MODE off.

f. CHECK—1 cycle is displayed per 2 horizontal divisions for each A SEC/DIV setting from 100 ms to 100 ns.

g. Disconnect the test setup.

2. Check External Z-Axis Operation.

a. Set:

INTENSITY	Fully clockwise
A SEC/DIV	1ms
CH 1 VOLTS/DIV	500 mV

Performance Check—2445A/2455A Service

b. Connect a 1-kHz, 2-V standard-amplitude signal from the Calibration Generator to the CH 1 OR X input connector and the rear-panel EXT Z-AXIS input connector using a 50-Ω BNC T-Connector and two 50-Ω BNC cables.

c. CHECK—The positive portion of the 4-division signal display is blanked out.

d. Disconnect the test setup and adjust the CRT INTENSITY as desired.

3. Check A and B GATE Outputs and Verify TRIGGER HOLDOFF.

a. Set:

A SEC/DIV	100 μs
B SEC/DIV	50 μs (knob in)
Δt	Off (DLY readout)
TRIGGER MODE	AUTO
TRIGGER HOLDOFF	Minimum (CCW)
Δ REF OR DLY POS	Zero DLY readout

NOTE

On CTT instruments, rotate the Δ REF OR DLY POS control for the specified delay. As the control is rotated, the readout delay value will be followed by the word "SET", denoting the indirect measurement mode. A few seconds after control movement has stopped, the word "SET" will disappear and the readout will display the direct measurement from the CTT.

b. Connect a test oscilloscope to the A GATE OUT connector (located on the instrument rear panel) via a 50-Ω BNC cable.

c. CHECK—Test oscilloscope displays a signal with a high level between 2.4 V and 5 V and a low level between 0 V and 0.4 V.

d. VERIFY—Duration of the high level is between 1 ms and 1.2 ms.

e. VERIFY—Duration of the low level is between 80 μs and 150 μs.

f. VERIFY—Duration of the low level increases to at least 10 times the time measured in part e when the HOLDOFF control is rotated to the maximum CW position but not in the detent.

g. Move the 50-Ω BNC cable from the A GATE OUT connector to the B GATE OUT connector.

h. CHECK—Test oscilloscope displays a signal with a high level between 2.4 V and 5 V and a low level between 0 V and 0.4 V.

i. VERIFY—Duration of the high portion of the signal is between 500 μs and 600 μs.

j. Disconnect the test setup.

ADDITIONAL FUNCTIONAL VERIFICATION

Equipment Required (see Table 4-1)

10X Probe supplied with Oscilloscope (Item 7)

INITIAL CONTROL SETTINGS

Control settings not listed do not affect the procedure.

a. Set:

NOTE

Select channels to set VOLTS/DIV.

VERTICAL

CH 1 and CH 2 VOLTS/DIV	0.1 V
CH 1 and CH 2 VAR	In detent
CH 3 and CH 4 VOLTS/DIV	0.1 V
CH 1, CH 2, CH 3, CH 4, ADD, and INVERT	Off
CHOP/ALT	ALT
20 MHz BW LIMIT	Off
CH 1 and CH 2 Input Coupling	1 M Ω DC

HORIZONTAL

A SEC/DIV	1 ms (knob in)
SEC/DIV VAR	In detent
X10 MAG	Off
TRACE SEP	Fully CW

Delta

ΔV and Ωt	Off (press and release until associated readout is Off)
TRACKING	Off

TRIGGER

HOLDOFF	B ENDS A (fully CW)
LEVEL	Midrange
SLOPE	+ (plus)
A/B TRIG Select	A
MODE	AUTO
SOURCE	VERT
COUPLING	DC

1. Verify ALT, CHOP, and ADD Modes and TRACE SEP.

a. VERIFY—CH 1 trace is visible with no VERTICAL MODE buttons selected.

b. Press the CH 2 VERTICAL MODE button.

c. VERIFY—CH 1 trace is not displayed and the CH 2 trace is displayed.

d. Press the CH 1 VERTICAL MODE button.

NOTE

Separate the traces by approximately 1 division using the VERTICAL POSITION controls. Do not position either trace precisely at graticule center.

e. VERIFY—Both the CH 1 and the CH 2 traces are displayed.

f. Press the ADD button.

g. VERIFY—A third trace (ADD) is displayed.

h. Press the CH 3 VERTICAL MODE button.

i. VERIFY—The CH 3 trace is added to the display.

j. Press the CH 4 VERTICAL MODE button.

k. VERIFY—The CH 4 trace is added to the display.

l. Set the SEC/DIV controls to 50 ms (knob in).

Performance Check—2445A/2455A Service

m. VERIFY—5 traces are alternately displayed in the following sequence: CH 1, CH 2, ADD, CH 3, CH 4.

n. Set the TRIGGER MODE to SGL SEQ.

o. VERIFY—After the current sequence of traces is complete, no further traces are displayed.

p. Set the TRIGGER SOURCE to LINE.

q. Press and release the lower TRIGGER MODE button.

r. VERIFY—Each time the lower TRIGGER MODE button is pressed and released, the 5 signal traces appear once (in sequence), the readout display flashes once and the scale illumination flashes on and off.

s. Set the TRIGGER MODE to AUTO LVL and press the CHOP button.

t. VERIFY—The 5 traces appear to be displayed simultaneously.

u. Set:

TRIGGER SOURCE	CH 4
A SEC/DIV	20 μ S
B SEC/DIV	10 μ S (knob out)
CHOP/ALT	ALT
TRACE SEP	CCW until traces are separated

v. VERIFY—An alternate B sweep trace appears for each A sweep trace (10 traces total).

2. Verify BEAM FIND Operation.

a. Set:

HORIZONTAL

POSITION	Midrange
A SEC/DIV	1 ms (knob in)
X10 MAG	On

VERTICAL

CH 1	On
CH 2, CH 3, CH 4 and ADD POSITION	Off Midrange

b. Press and hold the BEAM FIND button.

c. VERIFY—The trace is less than 10 divisions long and remains in the graticule area as the CH 1 POSITION control and the Horizontal POSITION control are rotated through their complete ranges.

d. Release the BEAM FIND button and set the VERTICAL POSITION and Horizontal POSITION controls to midrange.

3. Check Probe Encoding.

NOTE

Refer to instrument "Operators Manual", for the positioning of the readout display information.

a. Set:

CH 1, CH 2, CH 3, CH 4 VERTICAL MODE	On
CH 1 and CH 2 VOLTS/DIV	100 mV
CH 3 and CH 4 VOLTS/DIV	0.1

b. Connect the standard accessory 10X probe (encoded) to the CH 1 input connector.

c. CHECK—CH 1 readout changes from 100 mV to 1 V.

d. Move the probe to CH 2 and repeat part c for that channel.

e. Move the probe to CH 3.

f. CHECK—Readout changes from 0.1 to 1.

g. Move the probe to CH 4 and repeat part f for that channel.

h. Disconnect test setup.

i. Short a probe coding ring to ground.

j. CHECK—Readout changes to ID for that channel and the trace jumps up approximately 0.5 divisions.

k. Repeat steps i and j for each VERTICAL channel.

WORD RECOGNIZER CHECKS

Equipment Required (see Table 4-1)

10X Probe supplied with Oscilloscope (Item 7)
 T connectors (Item 8)
 BNC Cables (Item 10)

Pulse Generators (Item 24)
 Adapter (Item 25)
 Adapter (Item 26)

INITIAL CONTROL SETTINGS

Control settings not listed do not affect the procedure.

NOTE

Select channels to set VOLTS/DIV.

a. Set:

VERTICAL

CH 1 and CH 2 VOLTS/DIV	2 V
CH 3 VOLTS/DIV	500 mV
CH 4 VOLTS/DIV	100 mV
CH 1, CH 2, CH 3	On
CH 1 and CH 2 Input Coupling	50 Ω DC

HORIZONTAL

A and B SEC/DIV	200 ns (knob in)
-----------------	------------------

Delta

Δt and ΔV	Off (press and release until associated readout is off)
---------------------------	---

TRIGGER

SOURCE	CH 1
MODE	AUTO LVL

b. Connect the + trigger output of pulse generator # 1 via a 50- Ω cable to the + trigger input of pulse generator # 2.

c. Connect the output of pulse generator # 1 via a 50- Ω cable and T connector to the CH 1 input connector. Use the T connector at the CH 1 input.

d. Connect the output of pulse generator # 2 via a 50- Ω cable and T connector to the CH 2 input connector. Use the T connector at the CH 2 input.

e. Connect the Word Recognizer probe to the P6407 input connector at the rear of the instrument.

f. Connect a BNC-male-to-dual-binding post adapter to the T connector on the CH 1 input, and connect another BNC-male-to-dual-binding post adapter to the T connector on the CH 2 input.

g. Connect a 4-inch bare wire (suitable for connecting a scope probe) to the red binding post of the adapter connected to the CH 1 input.

h. Connect a 4-inch bare wire (suitable for connecting a scope probe) to the red binding post of the adapter connected to the CH 2 input.

i. Connect a 2-inch bare wire (suitable for connecting a scope probe) to the black binding post of the adapter connected to the CH 2 input.

j. Connect both ground leads from the Word Recognizer probe to the bare wire on the black binding post on the CH 2 input.

k. Connect the CH 3 input to the WORD RECOG OUT connector using the instrument X10 probe and a BNC-male-to-probe-tip adapter.

Performance Check—2445A/2455A Service

l. Set pulse generator # 1 to produce a positive 0.5- μ s pulse every 1 μ s.

m. Set pulse generator # 2 to produce a positive 400-ns pulse when it receives an external trigger.

NOTE

The lowest point of the HI must not be lower than 2.0 V.

n. Set both pulse generators to produce pulses of + 0.6 V LO and + 2.0 V HI.

o. Push the A/B MENU button.

p. Use the Δ REF OR DLY POS control to underline **LOGIC-TRIG**.

q. Push the upper TRIGGER MODE button.

r. Turn either Δ control to underline **B:WR**.

s. Push the upper TRIGGER MODE button.

t. Turn the Δ REF OR DLY POSITION control to underline **RADIX**.

u. Turn the Δ control to underline **HEX**.

v. Push the upper TRIGGER MODE button.

w. Connect the clock (C) input of the Word Recognizer to the wire on the red binding post of the CH 1 input.

x. Connect the Q and W0-W15 inputs of the Word Recognizer to the wire on the red binding post of the CH 2 input.

y. Set the A and B SEC/DIV switch to 20 ns.

2. Check Data Setup Time.

a. For each test setup described in Table 4-11:

1. Vary (increase) the pulse duration of pulse generator # 2 until the active edge of the channel 2 signal falls about 10 ns after the trigger edge of the channel 1 signal.
2. CHECK—Channel 3 is not displaying a signal.
3. Vary (decrease) the pulse duration of pulse generator # 2, moving the active edge of the channel 2 signal to the left until channel 3 displays a stable signal.
4. Push the Δt button.
5. Turn the Δ REF OR DLY POS control to align the delta reference cursor with the first edge of the channel 2 signal.
6. Turn the Δ control to align the delta cursor with the first edge of the channel 1 signal.
7. CHECK—Reading is \leq 25 ns.
8. Push the Δt button.

**Table 4-11
Data Setup Time Checks**

Polarity		Word Recognizer Word Definition	A TRIGGER SLOPE
Pulse Generator # 1	# 2		
+	+	\downarrow -0-0000	-
+	-	\downarrow -1-FFFF	-
-	-	\uparrow -1-FFFF	+
-	+	\uparrow -0-0000	+

3. Check Data Hold Time.

a. For each test setup described in Table 4-12: Vary the pulse duration of pulse generator # 2 until the first edge of the channel 2 signal falls about 10 ns after the trigger edge of the channel 1 signal.

2. CHECK—A stable signal is displayed on channel 3.
3. Vary the pulse duration of pulse generator # 2, moving the first edge of the channel 2 signal to the left until channel 3 no longer displays a stable signal.
4. Push the Δt button.
5. Turn the Δ REF OR DLY POS control to align the delta reference cursor with the first edge of the channel 2 signal.
6. Turn the Δ control to align the delta cursor with the first edge of the channel 1 signal.
7. CHECK—Reading is > 4 ns.
8. Push the Δt button.

4. Check Minimum Clock Pulse Width.

a. Set pulse generator # 1 to produce a 5-ns positive pulse every 1 μ s.

b. Push the A/B MENU button to select A TRIGGER MODE.

c. Push the upper TRIGGER MODE button to reinitialize the auto-trigger level.

d. Push the A/B MENU button.

e. For each test setup described in Table 4-13:

1. If there is not a stable signal displayed on channel 3 (< 2.5 V amplitude), vary (increase) the pulse duration of pulse generator # 1 until channel 3 displays a stable signal.
2. Push the Δt button.
3. Turn the Δ REF OR DLY POS control to align the delta reference cursor with the leading edge of the channel 1 pulse.
4. Turn the Δ control to align the delta cursor with the trailing edge of the channel 1 pulse.
5. CHECK—Reading is ≤ 20 ns.
6. Push the Δt button.

**Table 4-12
Data Hold Time Checks**

Polarity		Word Recognizer Word Definition	A TRIGGER SLOPE
Pulse Generator # 1	# 2		
+	+	$\downarrow -1\text{-FFFF}$	-
+	-	$\downarrow -0\text{-0000}$	-
-	-	$\uparrow -0\text{-0000}$	+
-	+	$\uparrow -1\text{-FFFF}$	+

**Table 4-13
Minimum Clock Pulse Width Checks**

Polarity		Word Recognizer Word Definition	A TRIGGER SLOPE
Pulse Generator # 1	# 2		
+	+	$\uparrow -X\text{-XXXX}$	+
-	+	$\downarrow -X\text{-XXXX}$	-

5. Check Delay From Selected Edge to WORD RECOG OUT.

a. Set:

VERTICAL

CH3 and CH 4 On
 CH 1, CH 2, ADD,
 and INVERT Off
 CH 3 VOLTS/DIV 0.1 V (1 V with
 X10 probe attached)

HORIZONTAL

A and B SEC/DIV 20 ns

b. Connect the instrument X10 probe to the CH 4 input connector and the probe tip to the wire on the red binding post of the CH 1 input.

c. Set pulse generator # 1 to produce a 50-ns positive pulse every 10 μ s.

d. Set the A TRIGGER SOURCE to CH 4.

e. For each test setup described in Table 4-14:

1. Push the Δ t button.
2. Turn the Δ REF OR DLY POS control to align the delta reference cursor with the active edge of the channel 4 signal.
3. Turn the Δ control to align the delta cursor with the rising edge of the channel 3 signal.

4. CHECK—Reading is \leq 55 ns.

5. Push the Δ t button.

6. Check Word Recognition Delay.

a. Set pulse generator # 1 to produce a positive 0.5- μ s pulse every 1 μ s.

b. Disconnect the C input of the Word Recognizer from the wire on the red binding post of the CH 1 input.

c. Connect the Q and W0-W15 inputs of the Word Recognizer to the wire on the red binding post of the CH 1 input.

d. For each test setup described in Table 4-15:

1. Push the Δ t button.
2. Turn the Δ REF OR DLY POS control to align the delta reference cursor with the first edge of the channel 4 signal.
3. Turn the Δ control to align the delta cursor with the rising edge of the channel 3 signal.
4. CHECK—Reading is \leq 140 ns.
5. Push the Δ t button.

e. Disconnect the probe on the CH 4 input.

Table 4-14
Delay From Selected Edge to
WORD RECOG OUT Checks

Polarity		Word Recognizer Word Definition	A TRIGGER SLOPE
Pulse Generator # 1	# 2		
+	+	\uparrow -X-XXXX	+
-	+	\downarrow -X-XXXX	-

Table 4-15
Word Recognition Delay

Polarity		Word Recognizer Word Definition	A TRIGGER SLOPE
Pulse Generator # 1	# 2		
+	+	X-1-FFFF	+
-	+	X-0-0000	-

7. Check Data Input Coincidence.

a. Set:

CH 4 VERTICAL MODE	Off
CH 2 and CH 3	
VERTICAL MODE	On
CH 3 VOLTS/DIV	.5 V (5 V with X10 probe attached)
A and B SEC/DIV	50 ns (knob in)
A TRIGGER SOURCE	CH 2
A TRIGGER SLOPE	- (minus)

b. Set pulse generator # 1 to produce a positive 0.5- μ s pulse every 1 μ s.

c. Set pulse generator # 2 to produce a negative 5-ns pulse when it receives an external trigger.

d. Set the A and B SEC/DIV to 20 ns (knob in).

e. Set the Word Definition of the Word Recognizer probe to BX0 0000.

f. Connect the Q and W0-W15 inputs of the Word Recognizer to the wire on the red binding post of the CH 2 input.

g. Push the A/B MENU button to select A TRIGGER MODE.

h. Push the upper TRIGGER MODE button to reinitialize the auto-trigger level.

i. Vary (increase) the pulse duration of pulse generator # 2 until further increase makes the channel 3 display stable (> 2.5 V amplitude).

j. Push the Δ t button.

k. Turn the Δ REF OR DLY POS control to align the delta reference cursor with the falling edge of the channel 2 signal.

l. Turn the Δ control to align the delta cursor with the rising edge of the channel 2 signal.

m. CHECK—Reading is ≥ 20 ns and ≤ 85 ns.

n. Push the Δ t button.

o. Disconnect test setup.

ADJUSTMENT PROCEDURE

INTRODUCTION

IMPORTANT—PLEASE READ BEFORE USING THIS PROCEDURE

The "Adjustment Procedure" is used to restore optimum performance or return the instrument to conformance with its "Performance Requirements" as listed in the "Specification" (Section 1). As a general rule, these adjustments should be performed every 2000 hours of operation or once a year if used infrequently.

PARTIAL PROCEDURES

This procedure is divided into subsections to permit calibration of individual sections of the instrument whenever complete instrument calibration is not required. To perform a partial procedure, first set the instrument as directed in the Initial Setup Conditions at the beginning of the section, then make any changes called for within the procedure. Perform all steps within a subsection, both in the sequence presented and in their entirety, to ensure that control settings will be correct for the following steps.

The adjustments in CAL 01, 02, 03, and 04 should be performed in numerical sequence, i.e., CAL 01 should be done before CAL 02, CAL 02 should be done before CAL 03, etc. Performing partial procedures when setting the automatic calibration constants (i.e., only one or two of the CAL steps) is not recommended and should only be done if the calibration constants set in the preceding steps are known to be correct.

BEFORE YOU BEGIN:

NOTE

When performing any of the automatic calibration routines (CAL 01 through CAL 07), the CAL/NO CAL jumper P501 must be moved to its CAL position (between pins 1 and 2) before turning the power on. When the desired calibration has been performed, return the jumper to its NO CAL position.

a. Turn instrument Power on.

NOTE

The instrument MUST have a 20-minute warmup period before making any adjustments. Performing the adjustment procedure while the temperature is drifting may cause erroneous calibration settings.

POWER SUPPLIES

Equipment Required (see Table 4-1)

Oscilloscope With 10X Probe (Item 7)	Alignment Tool (Item 20)
Digital Multimeter (Item 19)	1X Probe (Item 21)

See **ADJUSTMENT LOCATIONS 1** and **ADJUSTMENT LOCATIONS 4**

at the back of this manual for test point and adjustment locations.

NOTE

If the instrument displays "DIAGNOSTIC. PUSH A/B TRIG TO EXIT" at power-on, one of the power-up tests has failed. If the error message on the bottom line of the display is "TEST 04 FAIL xx" where "xx" is 01, 10 or 11, stored calibration data is in error, and the instrument should be recalibrated. If this is the case, pressing the A/B TRIG button will force entry to the normal operating mode; however, the accuracy of any measurement taken could be in error.

If any other error message occurs, the failure is probably not related to calibration. In this case, the instrument should be repaired before attempting calibration.

INITIAL CONTROL SETTINGS

Controls settings not listed will not affect the procedure.

VERTICAL

CH 2 VOLTS/DIV	100 mV
CH 3 and CH 4 VOLTS/DIV	.1 V
CH 1 and CH 2 VAR	In detent
CH 1 and CH 2 Input Coupling	1 MΩ DC
CH 1	On
CH 2, CH 3, and CH 4	Off
ADD, INVERT, and BW LIMIT	Off
ALT/CHOP	ALT
POSITION	Midrange

HORIZONTAL

SEC/DIV	X-Y (knob in)
SEC/DIV VAR	In detent
POSITION	Midrange

TRIGGER

MODE	AUTO LVL
SOURCE	VERT
COUPLING	DC
SLOPE	+ (plus)
LEVEL	Midrange
HOLDOFF	In detent

Delta

ΔV and Δt	Off (press and release until readout display disappears)
-----------	--

Display

INTENSITY	Visible display
READOUT INTENSITY	Visible display (CCW from MIN)
SCALE ILLUM	Fully CCW
FOCUS	Defocused dot

1. Check/Adjust Power Supply DC Levels, Regulation, and Ripple (R1292).

a. Connect the Digital Multimeter (DMM) negative lead to chassis ground. Connect the positive lead to the first test point listed in Table 5-1 (all test points are on the Main Board).

b. CHECK—That the reading is within the limits given in Table 5-1.

c. ADJUST—Volt Ref Adj (R1292) for a DMM reading of precisely 10.00 V. The adjustment is accessible through a hole in the top cover plate.

Table 5-1
Power Supply Voltage and Ripple Tolerances

Power Supply	Test Point (+ Lead)	Reading	Total p-p Ripple	p-p Ripple at Two Times Line Frequency
+10 V	J119-4	+9.99 to +10.01	100 mV	1 mV
+87 V	J119-8	+85.26 to +88.74	80 mV	5 mV
+42.4 V	J119-9	+41.55 to +43.25	80 mV	2 mV
+15 V	J119-6	+14.775 to +15.225	15 mV	11 mV
Digital +5 V	J119-2	+4.85 to +5.15	150 mV	30 mV
Analog +5 V	J119-12	+4.925 to +5.075	15 mV	1 mV
-5 V	J119-5	-4.965 to -5.035	15 mV	1 mV
-8 V	J119-11	-7.88 to -8.12	100 mV	1 mV
-15 V	J119-1	-14.775 to -15.225	10 mV	2 mV

d. Repeat parts a and b for the other test points listed in Table 5-1.

g. Using a 1X probe, connect the test oscilloscope probe ground lead to chassis ground. Connect the probe tip to the first test point listed in Table 5-1.

e. Disconnect the DMM.

f. Set the test oscilloscope as follows:

Sweep Speed	5 ms/div
CH 1 Input Coupling	1 M Ω AC
Vertical controls	To display CH 1
Trigger controls	Line source, triggered display
Volts/Division	2 mV
BW Limit	20 MHz

h. CHECK—Ripple at two times the line frequency and the total peak-to-peak ripple do not exceed the values given in Table 5-1.

i. Repeat part h for each test point in Table 5-1.

j. Disconnect the test oscilloscope.

CRT ADJUSTMENTS

Equipment Required (see Table 4-1)

Leveled Sine-Wave Generator (Item 2)	Digital Multimeter (Item 19)
Time-Mark Generator (Item 6)	Alignment Tool (Item 20)
50 Ω BNC Cable (2 required) (Item 10)	

See **ADJUSTMENT LOCATIONS 2**

at the back of this manual for test point and adjustment locations.

NOTE

All CRT adjustments (other than the Front-Panel ASTIG, FOCUS, and TRACE ROTATION adjustments) are accessed through the High Voltage shield located on the left side of the instrument near the rear of the CRT. The location of each adjustment is indicated on the shield.

INITIAL CONTROL SETTINGS

VERTICAL

CH 1 and CH 2 VOLTS/DIV	100 mV
CH 1 and CH 2 VAR	In detent
CH 1 and CH 2 Input Coupling	1 MΩ GND
CH 2 and BW LIMIT	On
CH 1, CH 3, CH 4 ADD and INVERT	Off
ALT/CHOP	ALT
POSITION	Midrange

HORIZONTAL

SEC/DIV	X-Y (knob in)
SEC/DIV VAR	In detent
POSITION	Midrange

TRIGGER

MODE	AUTO LVL
SOURCE	VERT
COUPLING	DC
SLOPE	+ (plus)
LEVEL	Midrange
HOLD OFF	In detent

Delta

ΔV and Δt	Off (press and release until readout disappears)
TRACKING/INDEP	INDEP

Display

INTENSITY	Visible display
READOUT INTENSITY	SCALE FACTORS OFF
SCALE ILLUM	Fully CCW
FOCUS	Best focused display

1. Adjust ASTIG Preset (R977) and Grid Bias (R1878)

a. Position the dot in the center area of the graticule using the CH 1 and CH 2 POSITION controls.

b. Focus the displayed dot as well as possible using the front-panel FOCUS control.

c. ADJUST—ASTIG (R977 on the front panel), in conjunction with the FOCUS control, for the sharpest possible dot.

d. Connect the Digital Multimeter + lead to cathode of CR2631 on the control board and the – lead to chassis ground.

e. Set the DMM to measure approximately 1.0 volt.

f. Set the INTENSITY control knob for a DMM reading of 1.00 volts.

g. ADJUST—Grid Bias (R1878) for a barely visible dot.

h. CHECK—No dot is visible when the INTENSITY control is rotated fully CCW.

i. If necessary, repeat parts d and e until the CHECK in part h is correct.

j. Disconnect the DMM.

2. Adjust TRACE ROTATION (R975) and Y-Axis Alignment (R1848).

NOTE

If the previous step was not performed, first set up the Initial Control Settings at the beginning of the CRT adjustments, then proceed as follows.

a. Set:

SEC/DIV	50 μ s (knob in)
INTENSITY	As required for a well-defined trace
Δt	(Δt readout)
READOUT INTENSITY	As required for well-defined vertical cursors

b. Using the CH 2 Vertical POSITION control, align the trace with the center horizontal graticule line.

c. Position one of the Δt cursors to the center vertical graticule line using either the Δ or the Δ REF OR DLY POS control.

d. ADJUST—TRACE ROTATION (R975 on the front panel) to align the trace with the center horizontal graticule line.

e. ADJUST—Y-Axis Alignment (R1848) to align the Δt cursor with the center vertical graticule line.

f. Repeat parts d and e as necessary for the best aligned display.

3. Adjust Geometry (R1870)

NOTE

If the previous step was not performed, first set up the Initial Control Settings at the beginning of the CRT adjustments, then proceed as follows.

a. Set:

CH 2 Input Coupling	50 Ω DC
ΔV and Δt	Off (no readout)

b. Connect 10- μ s time markers from the Time-Mark Generator to the CH 2 input connector via a 50- Ω BNC cable.

c. Use the Horizontal POSITION control to align the time markers with the vertical graticule lines. Use the CH 2 POSITION control to align the base of the signal with the bottom graticule line.

d. Set the CH 2 VOLTS/DIV switch for at least a 6-division vertical display.

e. Use the CH 2 POSITION control to set the tops of the time markers to graticule center.

f. Set the CH 2 VOLTS/DIV switch one position clockwise to overscan the display.

g. ADJUST—Geometry (R1870) for minimum curvature of the time markers across the entire graticule.

h. Disconnect the test setup.

4. Adjust Edge Focus (R1864)

NOTE

If the previous step was not performed, first set up the Initial Control Settings at the beginning of the CRT adjustments, then proceed as follows.

a. Set:

CH 2 Input Coupling	50 Ω
CH 2 VOLTS/DIV	200 mV
INTENSITY	Midrange

Adjustment Procedure—2445A/2455A Service

b. Connect a 50-kHz, 8-division signal from the Leveled Sine-Wave Generator to the CH 2 input connector via a 50- Ω BNC cable.

c. Center the display on the graticule.

d. ADJUST—Edge Focus (R1864), FOCUS (front-panel control), and ASTIG (R977, front-panel preset) for the most uniform focus over the entire display.

e. Disconnect the test setup.

5. Adjust High Drive Focus (R1842)

NOTE

If the previous step was not performed, first set up the Initial Control Settings at the beginning of the CRT adjustments, then proceed as follows.

a. Set:

ΔV	On (ΔV readout)
CH 2 VOLTS/DIV	200 mV
CH 2 Input Coupling	50 Ω DC
SEC/DIV	200 ns (knob in)
READOUT INTENSITY	Fully CW
INTENSITY	Fully CW

b. Connect a 10-MHz, 6-division signal from the Leveled Sine-Wave Generator to the CH 2 input connector via a 50- Ω BNC cable.

c. Center the display on the graticule.

d. ADJUST—High Drive Focus (R1842) for the best overall focus of the trace and readout.

e. Disconnect the test setup.

DAC REF, CH 1 AND CH 2 INPUT CAPACITANCE, AND VERTICAL READOUT JITTER ADJUSTMENTS

Equipment Required

Calibration Generator (Item 3)	Digital Multimeter (DMM) (Item 19)
50 Ω BNC Cable (Item 10)	Alignment Tool (Item 20)
50 Ω Termination (Item 12)	Normalizer (Item 22)

See **ADJUSTMENT LOCATIONS 3** and **ADJUSTMENT LOCATIONS 4**
at the back of this manual for test point and adjustment locations.

INITIAL CONTROL SETTINGS

Control settings not listed do not affect the procedure.

VERTICAL

CH 1 and CH 2 VOLTS/DIV	100 mV
CH 1 and CH 2 VAR	In detent
CH 1 and CH 2 Input Coupling	1 M Ω DC
CH 1	On
CH 2, CH 3, CH 4	Off
ADD, INVERT, and BW LIMIT	Off
ALT/CHOP POSITION	ALT Midrange

HORIZONTAL

A SEC/DIV	100 μ s (knob in)
SEC/DIV VAR	In detent
POSITION	Midrange

TRIGGER

MODE	AUTO LVL
SOURCE	VERT
COUPLING	DC
SLOPE	+ (plus)
LEVEL	Midrange
HOLDOFF	In detent

Delta

Δ t TRACKING/INDEP	On (Δ t readout) INDEP
---------------------------	-----------------------------------

Display

INTENSITY	Left of center
READOUT INTENSITY	As required for a visible display
SCALE ILLUM	Fully CCW
FOCUS	Best focused display

1. Adjust DAC Ref (R2010).

NOTE

The objective of this step is to make the total range of the DAC output voltage (sum of the CCW and CW readings) equal to 2.5 V.

a. Connect the digital multimeter (DMM) negative lead to the chassis ground. Connect the positive lead to pin 13 of J119 (on the Main Board).

b. Set the DMM to measure approximately 1.5 Vdc.

c. Rotate the Δ control CCW until the DMM reading remains at a constant value (approximately -1.250 V). Note the reading.

Adjustment Procedure—2445A/2455A Service

d. Rotate the Δ control CW until the DMM reading remains at a constant value (approximately +1.250 V). Note the reading.

e. Add the absolute values of the readings noted in parts c and d together (approximately 2.500 V).

f. Subtract the total in part e from 2.500 V, then divide the difference by two.

g. ADJUST—DAC Ref (R2010 on the Control Board) to add the (signed) number obtained in part f to the reading obtained in part d.

h. Repeat parts c through g as necessary to obtain a total DAC range of 2.500 V.

i. Disconnect the DMM.

2. Adjust CH 1 and CH 2 Input Capacitance (C105 and C205).

NOTE

If the previous step was not performed, first set up the Initial Control Settings before the DAC Ref adjustment, then proceed as follows.

NOTE

The objective of this adjustment is to match the input capacitance of the 50-mV-per-division position of the VOLTS/DIV switches to the 100-mV-per-division position. The front corner of an input square-wave signal is used to indicate when the capacitances are matched.

a. Connect a 1-kHz square-wave signal from the Calibration Generator high-amplitude output to the CH 1 OR X input connector via a 50- Ω BNC cable, a 50- Ω termination, and a normalizer. Adjust the generator output level for a 6-division signal vertically centered on the graticule.

b. Set the normalizer for a square front corner over approximately the first 40 μ s (0.4 division) of the positive portion of the waveform.

c. Change the CH 1 VOLTS/DIV switch to the 50-mV position and adjust the generator for a 6-division signal display.

d. ADJUST—The CH 1 50-mV C Adj (C105 on the Main Board) for the same waveform front corner noted in part b.

e. Repeat parts b through d until no change is observed in the waveform front corner when the CH 1 VOLTS/DIV switch is alternated between the 50-mV and 100-V positions. When switching between positions, reestablish the reference display amplitude at each position, and observe the square-wave front corner to make the comparison.

f. Move the input signal to CH 2 and change the VERTICAL MODE to display CH 2 only. Adjust the generator amplitude for a 6-division signal amplitude.

g. Set the normalizer for a square front corner over approximately the first 40 μ s (0.4 division) of the positive portion of the waveform.

h. Change the CH 2 VOLTS/DIV switch to the 50-mV position and adjust the generator for a 6-division display.

i. ADJUST—The CH 2 50-mV C Adj (C205 on the Main Board) for the same waveform front corner noted in part g.

j. Repeat parts g through i until no change is observed in the waveform front corner when the CH 2 VOLTS/DIV switch is alternated between the 50-mV and 100-V positions. When switching between positions, reestablish the reference signal amplitude at each position, and observe the square-wave front corner to make the comparison.

k. Disconnect the test setup.

3. Adjust Vertical Readout Jitter (R618).

NOTE

If the previous step was not performed, first set up the Initial Control Settings before the DAC Ref adjustment, then proceed as follows.

a. Set the VERTICAL MODE to display CH 1 only. Set the CH 1 Input Coupling to 50 Ω DC. Set the A SEC/DIV to 500 μ s.

b. Press and release the Δ V button to obtain a Δ V display.

Adjustment Procedure—2445A/2455A Service

c. Use the Δ REF OR DLY POS control to position one cursor 3 divisions above graticule center. Use the Δ control to position the other cursor 3 divisions below graticule center.

d. Connect a 1-kHz, fast-rise signal from the Calibration Generator to the CH 1 OR X input connector via a 50- Ω BNC cable.

e. Set the generator output level for an 8-division display.

f. Use the CH 1 Vertical and Horizontal POSITION controls to center the CH 1 display on the graticule.

g. ADJUST—Vertical Readout Jitter (R618) for minimum vertical jitter of the readout characters and cursors.

h. Disconnect the test setup.

AUTOMATIC CALIBRATION CONSTANTS, HORIZONTAL AND VERTICAL GAIN, CENTERING, AND TRANSIENT RESPONSE ADJUSTMENTS

NOTE

Within the following procedure, the calibration constants for timing, vertical gain and trigger level are generated by the system microprocessor and are stored in nonvolatile memory. The adjustments in CAL 01, 02, 03, and 04 should be performed in numerical sequence; i.e., CAL 01 should be done before CAL 02, CAL 02 should be done before CAL 03, etc. Performing partial procedures (i.e., only one or two of the CAL steps) is not recommended and should only be done if the calibration constants that would have been set in the preceding steps are known to be correct.

The CAL functions are available only if the CAL/NO CAL jumper (P501 on the Control Board) is in the CAL position (between pins 1 and 2) when power is turned on. When the automatic calibration procedures are completed, return the jumper to the NO CAL position to prevent entry into the calibration routines.

Equipment Required (see Table 4-1)

Calibration Generator (Item 3)	5X Attenuator (Item 17)
Time-Mark Generator (Item 6)	Digital Multimeter (DMM) (Item 19)
Oscilloscope (Item 7)	Alignment Tool (Item 20)
50 Ω BNC Cable (Item 10)	Tunnel Diode Pulser (Item 23)

See ADJUSTMENT LOCATIONS 4

at the back of this manual for test point and adjustment locations.

INITIAL CONTROL SETTINGS

CAL/NO CAL jumper CAL position (between pins 1 and 2) prior to turning on power

b. CHECK—Top line of the readout display says: "DIAGNSTIC. PUSH A/B TRIG TO EXIT".

NOTE

NOTE

When performing the automatic CAL steps, the initial setup of front-panel controls is not required.

The "menu" of calibration, test, and exercise routines is in a loop that may be scrolled through in single steps, either forward or backward. Pressing the upper or lower TRIGGER MODE switch and releasing it respectively increments or decrements the menu position by one. As each routine is selected, its name appears in the lower left corner of the readout display.

CAL 01—HORIZONTAL

1. Check/Adjust Horizontal Timing, X1 Gain (R860), X10 Gain (R850), Hrz Ctr (R801), and Trans Resp (R802).

a. Simultaneously press in and hold the Δt and the ΔV push buttons, then press and hold the SLOPE switch. Hold all three switches in for approximately one second, then release them.

When performing a calibration step, touch only the specific control or controls called out in the procedure. Movement of other controls may cause erroneous calibration results.

c. Scroll to CAL 01.



Upon entering CAL 01, the Input Coupling is automatically set to 50 Ω DC and the 50-Ω OVERLOAD protection is disabled. Before starting the procedure, make sure any 50-Ω OVERLOAD condition has been cleared.

In this procedure, pressing the upper TRIGGER COUPLING switch stores the current calibration parameter being set and increments the routine to the next step (except where otherwise noted).

d. Connect the DMM, set to measure approximately 500 mV, to the CALIBRATOR output.

e. Press and release the upper TRIGGER COUPLING switch.

NOTE

The CALIBRATOR output will go to its LO level on odd CAL steps and to its HI level on even steps.

f. CHECK—Readout indicates ADJUST Δ (step) 0, CH 1 PROBE TO FRONT SIDE OF R489.

g. Connect a P6136 probe from CH 1 to the front side of R489, at rear of main board near readout connector.

h. ADJUST—Δ REF to center signal on displayed cursors, and ADJUST—Δ control to join traces.

i. Press and release the upper TRIGGER COUPLING switch.

j. CHECK—CALIBRATOR output voltage is 0 mV ± 1 mV.

k. Disconnect the X10 probe.

l. CHECK—Readout indicates ADJUST Δ (step) 1, 100 μs (for A Sweep), and 1 μs (for B Sweep).

NOTE

The readout prompts the operator by showing the control to be moved (upper left corner), the autocal step number (upper right corner), the A-Sweep speed (bottom right center), and the B-Sweep speed (bottom right corner) as set up by the routine. An example (from step g above) is:

ADJ Δ		1
	100 μs	1 μs

m. Connect the Time-Mark Generator, set for 0.1-ms time markers, to the CH 1 OR X input connector via a 50-Ω BNC cable.

n. Set:

VOLTS DIV	As needed for a convenient signal display amplitude
TRACE SEP	As needed to separate the A and B Sweeps
CH 1 POSITION	As needed to view both A and B Sweeps
Horizontal POSITION	Position start of trace at the left graticule line

NOTE

Some sequential pairs of steps are iterative, i.e., the earlier step is recalled if an adjustment is made in the later step. Occasionally, on the earlier of some of these pairs, the readout may indicate "LIMIT" before the correct control setting is reached. If this occurs, proceed to the next AUTOMATIC CAL step. After the adjustment at the next step is performed, the previous step will automatically be recalled, and the adjustment may be performed in the normal manner.

o. ADJUST—Δ REF OR DLY POS and Δ controls to align both the intensified zones with the 6th time marker (near graticule center) and to superimpose the delayed B-Sweep time markers. Press and release the upper TRIGGER COUPLING switch.

p. CHECK—CALIBRATOR output voltage is between 398 mV and 402 mV of the reading noted in part j. Disconnect the DMM when through.

Adjustment Procedure—2445A/2455A Service

q. CHECK—Readout indicates ADJ Δ (step) 2, 100 μs (for A Sweep), and 1 μs (for B Sweep).

r. ADJUST—Δ REF OR DLY POS control to intensify the 2nd time marker, and ADJUST—Δ control to intensify the 10th time marker. Superimpose the delayed B-Sweep time markers within 0.2 division.

s. Press and release the upper TRIGGER COUPLING switch.

t. CHECK—Readout indicates ADJ Δ (step) 3, 300 μs (for A Sweep), and 1 μs (for B Sweep).

u. ADJUST—Δ REF OR DLY POS control to intensify the 4th time marker, and ADJUST—Δ control to intensify the 28th time marker. Superimpose the delayed B-Sweep time markers within 1.2 divisions.

v. Press and release the upper TRIGGER COUPLING switch. If the adjustment in step 3 was changed, step 2 will be recalled; otherwise step 4 will be initiated.

w. CHECK—Readout indicates ADJ Δ (step) 4, 100 μs (for A Sweep), and 1 μs (for B Sweep). Set the Time-Mark Generator for 5-μs time markers.

x. ADJUST—Δ control CCW until no further movement of the B-Sweep display occurs. Note the position of the 1st time marker, then adjust the Δ control CW until the 2nd time marker moves to the left and aligns with the position just noted.

NOTE

Movement of the Δ REF control at this point will adversely affect the calibration.

y. Press and release the upper TRIGGER COUPLING switch. Set the Time-Mark Generator for 10-μs time markers.

z. CHECK—Readout indicates X1, X10, HRZ CTR, (step) 5, and 10 μs (for A Sweep) and two vertical cursors appear on the display.

aa. ADJUST—X1 Gain (R860) and Hrz Ctr (R801) to align the two cursors with the 2nd and 10th vertical graticule lines, then adjust X10 Gain (R850) for 1 time marker per division.

bb. Press and release the upper TRIGGER COUPLING switch. Set the Time-Mark Generator for 10-ms time markers.

cc. CHECK—Readout indicates ADJ Δ (step) 6, 10 ms (for A Sweep), and 100 μs (for B Sweep).

dd. ADJUST—Δ REF OR DLY POS control to intensify the 2nd time marker, and ADJUST—Δ control to intensify the 10th time marker. Superimpose the delayed B-Sweep time markers within 0.2 division.

ee. Press and release the upper TRIGGER COUPLING switch. Set the Time-Mark Generator for 1-μs time markers.

**Table 5-2
Horizontal Timing**

Step Number	Time-Marker Period	ΔREF Marker	Δ Marker	Superposition Tolerance In Divisions
7	1 μs	2	10	0.2
8	2 μs	2	10	0.2
9	2 μs	4	28	1.2
10	10 μs	2	10	0.2
11	50 μs	2	10	0.2
12	50 μs	4	28	1.2
13	0.5 μs	2	10	0.2
14	0.5 μs	4	28	1.2
15	0.1 μs	2	10	0.2
16 ^a	20 ns	2	10	0.2 ^a

***Note the amplitude of the time markers. Use the Δ control to adjust for one time mark per division on the A sweep. Select 5-ns time markers. Adjust CH 1 VOLTS/DIV to obtain at least a 3-division signal. Use the Δ control to superimpose the B-Sweep markers within 0.2 divisions. Select 20-ns time markers and return the VOLTS/DIV to the amplitude noted above. Press upper TRIGGER COUPLING switch to store the calibration constant.**

ff. For each step in Table 5-2, do the following:

1. Adjust the Δ REF OR DLY POS and Δ controls, as necessary, to intensify the indicated time marks on the A Sweep and superimpose the displayed B-Sweep markers within the listed limits.
2. Press and release the upper TRIGGER COUPLING switch.

NOTE

If the Δ control is adjusted at step 9, 12 or 14, the previous step will be repeated.

gg. Set the TRACE SEP fully CW.

hh. Connect the Time Mark Generator output to CH 1 of both the IUT (instrument under test) and the bench scope via a BNC "T" and two 50- Ω BNC cables. Connect B GATE OUT of IUT to CH 2 of bench scope via a 50- Ω BNC cable.

ii. Set bench scope to view CH 1, TRIGGER SOURCE to CH 2, and CH 1 and CH 2 input coupling to 50 Ω .

jj. For each step in Table 5-3 (except step 28), adjust the Δ control for roughly the listed number of markers over the center 8 divisions, then superimpose markers on bench scope. Manually set SEC/DIV setting of bench scope to keep a usable time mark. Use IUT DELAY POS to bring markers on the bench scope screen. Some sweep speeds might require adjusting holdoff to see both markers. When markers are superimposed, press and release the upper TRIGGER COUPLING switch. If the Δ control is adjusted at step 18, 20, 23 or 25, the previous step will be repeated. At step 28, adjust Trans Resp (R802 on the Main Board) as indicated.

NOTE

Change the CH 1 VOLTS/DIV switch setting as necessary to maintain adequate signal display amplitude.

NOTE

If the remainder of the Adjustment Procedure will not be performed (in totality), readjustment of Horizontal Readout Jitter (R805) may be necessary (see subsection 3) if the X1 Gain (R860) or the X10 Gain (R850) was changed.

kk. Disconnect the test setup.

**Table 5-3
Horizontal Timing**

Step No.	Bench Scope Time/DIV	Time-Marker Period	Markers Over 8 Divisions	Superposition Tolerance In Divisions
17	200 ns and X10 (20 ns)	1 μ s	8	0.2
18	200 ns and X10 (20 ns)	1 μ s	24	1.2
19	500 ns and X10 (50 ns)	2 μ s	8	0.2
20	500 ns and X10 (50 ns)	2 μ s	24	1.2
21	2 μ s and X10 (200 ns)	10 μ s	8	0.2
22	10 μ s and X10 (1 μ s)	50 μ s	8	0.2
23	10 μ s and X10 (1 μ s)	50 μ s	24	1.2
24	100 ns and X10 (10 ns)	500 ns	8	0.2
25	100 ns and X10 (10 ns)	500 ns	24	1.2
26	20 ns and X10 (2 ns)	100 ns	8	0.2
27	10 ns and X10 (1 ns)	20 ns	8	0.2
28 ^a	N/A	2 ns	2	1.2
29	200 μ s and X10 (20 μ s)	1 ms	8	0.2

^a Step 28 (used on the 2455A only) requires the 2-ns time marks to be input through a dual input coupler to CH 1 and CH 2. Select CH2 INVERT. Center the two waveforms. Adjust Trans Resp (R802) for precisely 2 cycles between the 2nd and 10th graticule lines at the INTERSECTIONS on the two waveforms. Maintain consistency in measurement by using both front or both rear edges of the trace.

CAL 02—VERTICAL

2. Check/Adjust Vertical Preamplifier Gain, Gain (R638), and Vertical Centering (R639).

NOTE

If the previous step (CAL 01) was not performed, the adjustments in this subsection should only be performed if those constants that would have been set in CAL 01 are known to be correct.

- a. Set the front-panel INTENSITY control at midrange.
- b. Scroll to CAL 02.
- c. Press and release the upper TRIGGER COUPLING switch. The instrument will automatically increment through steps 100 to 110.
- d. CHECK—Readout indicates CH 1 VAR, CH2 POS, (step) 111, and 500 mV.

NOTE

The readout prompts the operator by showing the controls to be moved (upper left corner and upper center), the autocal step number (upper right corner), the amplitude of signal to be applied to either the CH 1 or CH 2 connectors (lower left corner), and any other scope function that is enabled. An example (from step d above) is:

CH1 VAR CH2 POS 111

500 mV

- e. Connect a 0.5-V, standard-amplitude signal from the Calibration Generator to the CH 1 OR X input connector via a 50-Ω BNC cable.
- f. Use the CH 2 POSITION control to vertically position the trace to within 1 division of the center graticule line.
- g. ADJUST—CH 1 POSITION and VOLTS/DIV VAR controls to obtain a 10-division horizontal signal. Press and release the upper TRIGGER COUPLING switch.

NOTE

When step 111 is performed, step 112 is also automatically done. No indication of step 112 will be shown unless a LIMIT error is indicated.

NOTE

In the following steps, if the "LIMIT" message appears, it probably indicates that the TRIGGER COUPLING (step) switch was moved before the required signal was applied. Press and release the lower TRIGGER COUPLING switch, verify that the correct signal is applied, then press and release the upper TRIGGER COUPLING switch.

- h. CHECK—First step number listed in Table 5-4 appears in the readout.
- i. Apply the corresponding standard-amplitude signal from the Calibration Generator, then press and release the upper TRIGGER COUPLING switch.
- j. Repeat steps h and i for each step-signal combination listed in Table 5-4.

**Table 5-4
Vertical Calibration Signals**

Autocal Step Readout Display	Standard-Amplitude Signal to Apply
113, 114 ^a	0.5 V
115	0.2 V
116	0.1 V
117	50 mV
118	20 mV
119	1 V
120	10 V

^aWhen step 113 is performed, step 114 is also automatically done. No indication of step 114 will be shown unless a LIMIT error is encountered.

- k. Move the signal to the CH 2 input connector.

l. CHECK—Readout indicates CONNECT SIGNAL TO CH 2, (step) 121, 500 mV, 500 mV, and BWL.

m. Set the Calibration Generator for a 500-mV standard-amplitude signal, then press and release the upper TRIGGER COUPLING switch.

NOTE

When step 121 is performed, step 122 is also automatically done. No indication of step 122 will be shown unless a LIMIT error is indicated.

n. CHECK—First step number listed in Table 5-5 appears in the readout.

o. Apply the corresponding standard-amplitude signal, then press and release the upper TRIGGER COUPLING switch.

p. Repeat steps n and o for each step-signal combination listed in Table 5-5.

**Table 5-5
Vertical Calibration Signals**

Autocal Step Readout Display	Standard-Amplitude Signal to Apply
123, 124 ^a	0.5 V
125	0.2 V
126	0.1 V
127	50 mV
128	20 mV
129	1 V
130	10 V

***When step 123 is performed, step 124 is also automatically done. No indication of step 124 will be shown unless a LIMIT error is encountered.**

q. CHECK—Procedure automatically steps through steps 130-141.

r. CHECK—Readout indicates CONNECT SIGNAL TO CH 1, 50 mV, and BWL.

s. Move the signal to the CH 1 OR X input connector and set the Calibration Generator for a 50-mv standard-amplitude signal, then press and release the upper TRIGGER COUPLING switch. Wait approximately 10 seconds for automatic calibration of the ΔV cursors.

t. CHECK—Readout indicates VERT CENTER GAIN.

u. ADJUST—Gain (R638) for precisely 5 divisions between the two horizontal cursors.

v. ADJUST—Vertical Centering (R639) to center the cursors on the graticule (align the cursors with the dotted 0% and 100(%) graticule lines).

w. Press and release the upper TRIGGER COUPLING switch. The microprocessor continues calibrating the vertical.

CAL 03—TRIGGERING

3. Check/Adjust Triggering.

NOTE

If the previous steps (CAL 01 and CAL 02) were not performed, the adjustments in this subsection should only be performed if those constants that would have been set in CAL 01 and CAL 02 are known to be correct and if a DC Balance has been performed after a 20-minute warmup period.

a. Scroll to CAL 03.

b. Press and release the upper TRIGGER COUPLING switch.

c. CHECK—Procedure automatically steps from 201 through 214 and stops at 215.

d. CHECK—Readout indicates CH 1, 500 mV, and (step) 215.

Adjustment Procedure—2445A/2455A Service

NOTE

The readout prompts the operator by showing to which connector the input signal should be applied (upper left corner), the amplitude of that signal (upper center), and the autocal step number (upper right corner). An example (from step d above) is:

CH1 500 mV 215

e. Connect a 0.5-V standard-amplitude signal from the Calibration Generator to the CH 1 OR X input connector via a 50- Ω BNC cable.

f. Press and release the upper TRIGGER COUPLING switch.

g. CHECK—Readout indicates CH 1, 500 mV, and (step) 216.

h. Press and release the upper TRIGGER COUPLING switch.

i. CHECK—Readout indicates CH 2, 500 mV, and (step) 217.

j. Move the signal to the CH 2 input connector. Press and release the upper TRIGGER COUPLING switch.

k. CHECK—Readout indicates CH 3, 500 mV, and (step) 218.

l. Move the signal to the CH 3 input connector. Press and release the upper TRIGGER COUPLING switch.

m. CHECK—Readout indicates CH 3, 2V, and (step) 219.

n. Change the generator output level to 2 V, then press and release the upper TRIGGER COUPLING switch.

o. CHECK—Readout indicates CH 4, 500 mV, and (step) 220.

p. Move the signal to the CH 4 input connector and change the generator output level to 0.5 V. Press and release the upper TRIGGER COUPLING switch.

q. CHECK—Readout indicates CH 4, 2V, and (step) 221.

r. Change the generator output level to 2 V, then press and release the upper TRIGGER COUPLING switch.

s. Disconnect the test setup.

CAL 04—CH 2 DELAY ENABLE/DISABLE

4. Check/Adjust CH 2 Delay Enable/Disable.

a. Scroll to CAL 04.

b. Press and release the upper TRIGGER COUPLING switch to initiate the routine.

c. CHECK—Readout alternately indicates "ENABLED" and "DISABLED" each time the upper TRIGGER COUPLING switch is pressed and released.

d. Leave the readout display indicating "ENABLED". Press and release the A/B TRIG button to exit the routine.

e. Connect a 100-kHz, positive-going signal from the Calibration Generator fast-rise output to the CH 1 OR X and CH 2 input connectors via a 50- Ω BNC cable, a 5X attenuator, and a Dual-Input Coupler.

f. Set:

VERTICAL

CH 1 and CH 2	On
CH 1 and CH 2	
VOLTS/DIV	10 mV
CH 1 and CH 2	
Input Coupling	50 Ω DC

HORIZONTAL

A SEC/DIV	10 ns (knob in)
-----------	-----------------

TRIGGER

SOURCE	CH 1
MODE	AUTO LVL
COUPLING	DC
SLOPE	+ (plus)

g. Set the generator amplitude for a 3- to 5-division display amplitude. Use the CH 1 and CH 2 POSITION controls to vertically overlay the traces near the center of the graticule area.

h. Set the Horizontal POSITION control to set the rising edge of the signals near the center vertical graticule line.

i. Press and release the X10 MAG button to obtain a magnified display.

j. Pull out the SEC/DIV knob.

k. CHECK—That the readout indicates “CH 2 DLY-TURN Δ ” and that the Δ control will move the leading edge of the CH 2 trace at least 0.5 division to either side of the CH 1 trace.

l. ADJUST— Δ control to superimpose the leading edges.

m. Push in the SEC/DIV knob.

NOTE

If the CH 2 Delay Adjust feature is to be disabled for normal instrument use, perform the following steps; otherwise, proceed to CAL 05.

n. Reenter the Diagnostic Monitor by pressing the ΔV and Δt buttons simultaneously (hold them in), then press and hold the TRIGGER SLOPE button. Release the buttons after about 1 second.

o. Scroll to CAL 04.

p. Press and release the upper TRIGGER COUPLING switch until the readout indicates “DISABLED.”

q. Press and release the A/B TRIG button to return to normal operating mode.

CAL 05—Set HRS ON and PWR ON/OFF cycles.

5. Check/Adjust Hours On and Power On/Off cycles.

a. Scroll to CAL 05.

b. Press and release the upper TRIGGER COUPLING switch to initiate the routine.

c. CHECK—Readout indicates HRS ON xxx PWR ON/OFF xxx and $\Delta\Delta$ REF HRS Δ PWR PUSH MAG 10/1.

d. Press and release the lower TRIGGER SOURCE and then press and release the lower TRIGGER MODE to reset HRS ON and PWR ON/OFF to zero.

NOTE

HRS ON and PWR ON/OFF can be set to any value from 0-99999 with the Δ REF and Δ controls.

e. Press and release the lower TRIGGER COUPLING switch to exit routine.

CAL 06—VERTICAL TRANSIENT RESPONSE

6. Check/Adjust Vertical Transient Response

a. Scroll to CAL 06.

b. Press and release the upper TRIGGER COUPLING switch to initiate the routine.

c. CHECK—Readout indicates ADJ Δ (step) 1, 10 mV, 100 ns.

Adjustment Procedure—2445A/2455A Service

d. Connect the high-amplitude output of the Calibration Generator to the CH 1 OR X input connector via a 50- Ω BNC cable, a Tunnel Diode Pulser, and a 5X attenuator.

e. Set the generator Period switch to 100 kHz, and set the generator amplitude control to maximum.

f. Rotate the pulser Trigger control CW (from a fully CCW position) until a stable signal first appears on the graticule. Display amplitude will be approximately 5 divisions. The oscilloscope TRIGGER LEVEL control may need to be adjusted to obtain a stable display.

NOTE

As a guide when performing the following adjustments, optimum performance is achieved when the CH 1 and CH 2 step response aberrations are $\leq 4\%$ when using 10 mV/division deflection factors (≤ 0.2 division on a 5-division signal).

g. Preset Trans Resp adjustments:

NOTE

Presetting the adjustments is not necessary unless vertical system components have been replaced.

1. Center CRT Termination (R1501).
2. Center Trans Resp adjustments R403, R605, and C601.
3. ADJUST—Trans Resp adjustment C404 for maximum positive movement of the front corner of the waveform.
4. Set Trans Resp adjustment R410 $\frac{1}{3}$ CCW from CW end.
5. On 2455A instruments, ADJUST—HF. Adjust (R417) full CW and then CCW until the adjustment slot runs front to back (approximately 90% CCW).

h. Press and release the upper TRIGGER COUPLING switch.

i. CHECK—Readout indicates ADJ Δ (step) 2, 10 mV.

j. ADJUST—C403 for best corner over first $\frac{1}{2}$ division (5 ns).

k. ADJUST—Trans Resp Adjustments C403, R410 for flattest corner over first 5 ns.

l. Turn A SEC/DIV VAR control CCW and ADJUST CRT termination (R1501) for flattest waveform.

m. Adjust Δ for the flattest waveform. Set SEC/DIV VAR for best viewing. The total system will tune up best if the indicator cursor is in the 7th or 8th divisions.

n. Press and release the lower TRIGGER COUPLING switch to return to Step 1 of CAL 06.

o. CHECK—Readout indicates ADJ Δ (step) 1, 10 mV, 100 ns.

p. ADJUST—Trans Resp adjustments (R605, R403, C404, and C601) for the flattest response in the first 100 ns.

q. Disconnect the Calibration Generator and connect the Primary Leveled Sine-Wave Generator to the CH 1 input via a 50- Ω BNC cable.

r. Set the generator for a 6-division display at 1 MHz.

s. Change the generator output frequency to 150 MHz for the 2445A or to 250 MHz for the 2455A.

t. CHECK—Display amplitude is between 4.4 divisions and 6 divisions while the generator frequency is changed from 100 MHz to 150 MHz for the 2445A or from 150 MHz to 250 MHz for the 2455A. This bandwidth provides optimum performance of the Vertical system.

u. CHECK—Display amplitude does not drop below 4.4 divisions when sweeping the generator frequency from 150 MHz to 100 MHz for the 2445A or from 250 MHz to 150 MHz for the 2455A.

v. On 2455A instruments, ADJUST—HF. Adjust (R417) if necessary to meet the criteria given in steps t and u.

w. Press and release the upper TRIGGER COUPLING switch.

x. Check—Readout indicates ADJ Δ (step) 2, 10 mV, 10 ns.

y. Connect the high amplitude generator, Tunnel Diode Pulsar, 5X attenuator combination to CH 1 OR X input via a 50- Ω BNC cable.

z. ADJUST—Trans Resp adjustments (R410, C403, and the Δ control) for best response.

aa. Disconnect the Tunnel Diode pulser and connect the fast rise output of the Calibration Generator to CH 1 OR X via a 5X attenuator and a 50- Ω BNC cable. Note the amount of roll up or roll down in the first 3 ns. This difference represents the error between the Tunnel Diode pulser and the fast rise generator.

bb. Press and release the upper TRIGGER COUPLING switch (step 3). Move the test signal to CH 2 and ADJUST—amplitude for 5-division signal.

cc. ADJUST— Δ until CH 2 waveform matches that noted in step aa above.

dd. Press and release the upper TRIGGER COUPLING switch (step 4). Connect the test signal to CH 1 through 2X, 2.5X, and 5X attenuators. ADJUST Δ for best front corner.

ee. Press and release the upper TRIGGER COUPLING switch (step 5). Remove 2.5X attenuator. ADJUST Δ for best corner.

ff. Press and release the upper TRIGGER COUPLING switch (step 6). Remove 5X attenuator. ADJUST generator for a 5-division signal. ADJUST Δ for same corner noted in step ee above.

gg. Press and release the upper TRIGGER COUPLING switch (step 7). Adjust generator for 5-division signal. ADJUST Δ for best corner.

hh. Press and release the upper TRIGGER COUPLING switch (step 8). Adjust generator for a 5-division signal. ADJUST Δ for best corner.

NOTE

Generator amplitude for the 500-mV step will be approximately 2 divisions and the amplitude for the 1-V step will be approximately 1 division.

ii. Remove 2X attenuator. Continue through step 11 as above.

jj. Press and release the upper TRIGGER COUPLING switch. Steps 12 and 13 are automatically calibrated. Connect test signal to CH 2 via 2X, 2.5X, and 5X attenuators and adjust for 5-division signal. ADJUST Δ for best corner.

kk. Repeat steps dd through ii for CH 2 (steps 14-21).

ll. Steps 22 and 23 are automatically calibrated after step 21.

mm. CHECK—Readout indicates VERT CENTER GAIN.

nn. ADJUST—Gain (R638) for precisely 5 divisions between the two horizontal cursors.

oo. ADJUST—Vertical Centering (R639) to center the cursors on the graticule (align the cursors with the dotted 0% and 100(%) graticule lines).

pp. Press and release the upper TRIGGER COUPLING switch.

qq. Disconnect the test setup.

CAL 07—READOUT CENTERING AND GAIN

7. Check/Adjust Readout Centering and Gain (R2918 R2931)

See **ADJUSTMENT LOCATIONS 1** at the back of this manual for test point and adjustment locations.

- a. Scroll to CAL 07.
- b. Press and release the upper TRIGGER COUPLING switch to initiate the routine.
- c. CHECK—Readout displays large 8 characters in the top line and BWL characters in the bottom line.
- d. ADJUST—Readout Centering (R2918) and Gain (R2931) so the top of the large 8's and the bottom of the BWL characters are ¼ to ½ minor division from the top and bottom Horizontal Graticule lines.
- e. Press and release the lower TRIGGER COUPLING switch.
- f. Return the CAL/NO CAL jumper to the NO CAL position.
- g. Press the A/B TRIG button to return to normal operation.

8. Adjust Bandwidth Limit.

- a. Set:

VERTICAL

CH 1	On
CH 2, CH 3, and CH 4	Off
CH 1 POSITION	Midrange
CH 1 VOLTS/DIV	10 mV
CH 1 VAR	In detent
CH 1 Input Coupling	1 MΩ DC
20 MHz BW LIMIT	On

HORIZONTAL

POSITION	Midrange
X10 MAG	Off
A SEC/DIV	1 μs (knob in)
SEC/DIV VAR	In detent

TRIGGER

HOLDOFF LEVEL	MIN (Fully CCW)
A/B TRIG	Midrange
SLOPE	A
MODE	+
SOURCE COUPLING	AUTO LVL
	VERT
	DC

- b. Connect a fast-rise, positive-going square-wave output via a precision 50-Ω cable, a 50-Ω 10X attenuator, and a 50-Ω termination to the CH 1 input connector.
- c. Set the generator to produce a 100-kHz, 5-division display.
- d. ADJUST—Coil L644 for as flat a response as possible.
- e. Disconnect the test equipment from the instrument.

DYNAMIC CENTERING, DC BALANCE, AND X-Y PHASE DIFFERENTIAL ADJUSTMENTS

Equipment Required (see Table 4-1)

Primary Leveled-Sine Wave Generator (Item 2)	5X Attenuator (Item 17)
Calibration Generator (Item 3)	Alignment Tool (Item 20)
50 Ω BNC Cable (Item 10)	

See **ADJUSTMENT LOCATIONS 1** and **ADJUSTMENT LOCATIONS 4**

at the back of this manual for test point and adjustment locations.

INITIAL CONTROL SETTINGS

Control settings not listed do not affect the procedure.

VERTICAL

CH 1 and CH 2	
VOLTS/DIV	10 mV
CH 1 VAR	CCW (out of detent)
CH 2 VAR	In detent
CH 1 and CH 2	
Input Coupling	50 Ω DC
CH 1	On
CH 2, CH 3 and CH 4	Off
ADD, INVERT, and	
BW LIMIT	Off
ALT/CHOP	ALT
POSITION	Midrange

HORIZONTAL

A SEC/DIV	10 μ s
B SEC/DIV	100 ns (knob in)
SEC/DIV VAR	In detent
POSITION	Midrange

TRIGGER

MODE	AUTO LVL
SOURCE	VERT
COUPLING	DC
SLOPE	+ (plus)
LEVEL	Midrange
HOLDOFF	Minimum (CCW)

Delta

Δ V	On (RATIO readout)
TRACKING/INDEP	INDEP
Δ REF OR DLY POS	
and Δ	

Cursors near the 3rd line above and 3rd line below graticule center (6 division spacing)

Display

INTENSITY	Left of center
READOUT INTENSITY	Right of center
SCALE ILLUM	Fully CCW
FOCUS	Best focused display

1. Adjust Dynamic Centering (R3401 and R3407).

a. Connect a 5-division, 6-MHz signal from the Primary Leveled Sine-Wave Generator to the CH 1 or X input via a 50- Ω BNC cable.

b. Rotate the INTENSITY control from fully CCW to fully CW and note any horizontal and vertical shift that occurs in the displayed waveform.

c. ADJUST—Horizontal Dynamic Centering (R3401) to minimize the horizontal component of the shift.

d. ADJUST—Vertical Dynamic Centering (R3407) to minimize the vertical component of the shift.

Adjustment Procedure—2445A/2455A Service

e. Repeat steps b through d as necessary to minimize trace shift until no further improvement is noted.

f. Disconnect the setup.

2. Check/Adjust Readout Jitter (R805 and R618).

NOTE

If the previous step was not performed, first set up the Initial Control Settings before the Dynamic Centering adjustments, then proceed as follows.

a. Rotate the Δ REF OR DLY POS control CCW until the RATIO readout is constant.

b. Rotate the Δ control until the readout display indicates 130.0%.

c. CHECK—One cursor is near the bottom horizontal graticule line and the other is near the dotted graticule line marked 100(%).

d. Rotate the Δ REF OR DLY POS control until the readout displays exactly 100.0%. The cursors should now be on or near the dotted graticule lines marked 0% and 100(%).

e. Set the CH 1 VOLTS/DIV VAR to the detent position.

NOTE

Care must be taken not to disturb the position of the controls adjusted in parts b through e during the balance of this procedure. If they are accidentally moved, repeat the procedure from the beginning.

f. Set the A SEC/DIV to 1 ms (knobs locked).

g. Select CH 1 for display.

h. Press and release the ΔV button to obtain a ΔV display, if necessary.

i. Connect a 1-kHz, fast-rise signal from the Calibration Generator to the CH 1 OR X input connector via a 50- Ω BNC cable.

j. Set the generator output level for an 8-division display.

k. Use the CH 1 Vertical and the Horizontal POSITION controls to center the CH 1 display on the graticule.

l. ADJUST—Vertical Readout Jitter (R618) for minimum vertical jitter of the readout characters and cursors.

m. ADJUST—Gain (R638) and Centering (R639) to align cursors with the 0 and 100% graticule markings.

n. Disconnect the 1-kHz signal.

o. Press the Δt button to obtain a Δt cursor display.

p. Using the Δ REF OR DLY POS and Δ controls, position the cursors to the 2nd and 10th graticule lines.

q. Press the X10 MAG button to magnify the display.

r. ADJUST—Horizontal Readout Jitter (R805) for minimum horizontal jitter of the readout characters and cursors.

3. Set CH 1 and CH 2 DC Balance.

NOTE

The instrument must have had a 20-minute warmup prior to performing the next step to ensure accuracy.

a. Set CH 1 and CH 2 Input Coupling to 1 M Ω AC.

b. Press and hold momentarily and then release the CH 1 and CH 2 upper Input Coupling switches simultaneously.

c. CHECK—The display reads DC BALANCE IN PROGRESS for approximately 10 seconds, then the display returns to normal.

d. CHECK—For less than 0.2-division + 0.5 mV vertical trace shift when the CH 1 VOLTS/DIV switch is rotated through all of its settings.

e. Set the VERTICAL MODE switches to disable CH 1 and display CH 2.

f. CHECK—For less than 0.2-division + 0.5-mV vertical trace shift when the CH 2 VOLTS/DIV switch is rotated through all of its settings.

4. Adjust X-Y Phasing (C118).

a. Set:

VERTICAL

CH 1	On
CH 2, CH 3, and CH 4	Off
CH 1 VOLTS/DIV	50 mV
CH 1 Input Coupling	50 Ω DC
BW LIMIT	Off

HORIZONTAL

SEC/DIV	X-Y
---------	-----

b. Connect the Primary Leveled Sine-Wave Generator to the CH 1 OR X input connector via a 50- Ω BNC cable.

c. Set the generator frequency to 1 MHz and adjust the amplitude for a 6-division vertical signal display.

d. Use the CH 1 POSITION control to vertically center the display on the graticule.

e. ADJUST—X-Y Phasing (C118) for no opening in the ellipse.

f. Set the generator frequency to 2 MHz and adjust the amplitude for a 6-division vertical signal display.

g. CHECK—Horizontal opening in the ellipse is 0.3 division or less, measured at the center horizontal graticule line.

i. Disconnect the test setup.

j. Turn POWER Off.

MAINTENANCE

This section of the manual contains information for conducting preventive maintenance, troubleshooting, and corrective maintenance on the instruments.

STATIC-SENSITIVE COMPONENTS

The following precautions are applicable when performing any maintenance involving internal access to the instrument.

CAUTION

Static discharge can damage any semiconductor component in this instrument.

This instrument contains electrical components that are susceptible to damage from static discharge. Table 6-1 lists the relative susceptibility of various classes of semiconductors. Static voltages of 1 kV to 30 kV are common in unprotected environments.

When performing maintenance, observe the following precautions to avoid component damage:

Minimize handling of static-sensitive components.

2. Transport and store static-sensitive components or assemblies in their original containers or on a metal rail. Label any package that contains static-sensitive components or assemblies.
3. Discharge the static voltage from your body by wearing a grounded antistatic wrist strap while handling these components. Servicing static-sensitive components or assemblies should be performed only at a static-free work station by qualified service personnel.
4. Nothing capable of generating or holding a static charge should be allowed on the work station surface.
5. Keep the component leads shorted together whenever possible.

6. Pick up components by their bodies, never by their leads.

Table 6-1
Susceptibility to Static Discharge Damage

Semiconductor Classes	Relative Susceptibility Levels ^a
MOS or CMOS microcircuits or discretes, or linear microcircuits with MOS inputs. (Most Sensitive)	1
ECL	2
Schottky signal diodes	3
Schottky TTL	4
High-frequency bipolar transistors	5
JFETs	6
Linear microcircuits	7
Low-power Schottky TTL	8
TTL (Least Sensitive)	9

^aVoltage equivalent for levels: (Voltage discharged from a 100 pF capacitor through a resistance of 100 Ω).

1 = 100 to 500 V 4 = 500 V 7 = 400 to 1000 V (est.)
 2 = 200 to 500 V 5 = 400 to 600 V 8 = 900 V
 3 = 250 V 6 = 600 to 800 V 9 = 1200 V

7. Do not slide the components over any surface.
8. Avoid handling components in areas that have a floor or work-surface covering capable of generating a static charge.

9. Use a soldering iron that is connected to earth ground.

10. Use only approved antistatic, vacuum-type desoldering tools for component removal.

PREVENTIVE MAINTENANCE

INTRODUCTION

Preventive maintenance consists of cleaning, visual inspection, and checking instrument performance. When accomplished regularly, it may prevent instrument malfunction and enhance instrument reliability. The severity of the environment in which the instrument is used determines the required frequency of maintenance. An appropriate time to accomplish preventive maintenance is just before instrument adjustment.

component breakdown. Dirt on components acts as an insulating blanket, preventing efficient heat dissipation. It also provides an electrical conduction path that could result in instrument failure, especially under high-humidity conditions.



Avoid the use of chemical cleaning agents which might damage the plastics used in this instrument. Use a nonresidue-type cleaner, preferably isopropyl alcohol or a solution of 1% mild detergent with 99% water. Before using any other type of cleaner, consult your Tektronix Service Center or representative.

GENERAL CARE

The cabinet minimizes accumulation of dust inside the instrument and should normally be in place when operating the instrument. The front cover supplied with the instrument provides both dust and damage protection for the front panel and CRT, and it should be on whenever the instrument is stored or is being transported.

Exterior

INSPECTION. Inspect the external portions of the instrument for damage, wear, and missing parts; use Table 6-2 as a guide. Instruments that appear to have been dropped or otherwise abused should be checked thoroughly to verify correct operation and performance. Deficiencies found that could cause personal injury or could lead to further damage to the instrument should be repaired immediately.

INSPECTION AND CLEANING

The instrument should be visually inspected and cleaned as often as operating conditions require. Accumulation of dirt in the instrument can cause overheating and

**Table 6-2
External Inspection Check List**

Item	Inspect For	Repair Action
Cabinet, Lid, Front Panel	Cracks, scratches, deformations, damaged hardware or gaskets.	Touch up paint scratches and replace defective components.
Front-Panel Controls	Missing, damaged, or loose knobs, buttons, and controls.	Repair or replace missing or defective items.
Connectors	Broken shells, cracked insulation, and deformed contacts. Dirt in connectors.	Replace defective parts, Clear or wash out dirt.
Carrying Handle	Correct operation.	Replace defective parts.
Accessories	Missing items or parts of items, bent pins, broken or frayed cables, and damaged connectors.	Replace damaged or missing items, frayed cables, and defective parts.

CAUTION

To prevent getting moisture inside the instrument during external cleaning, use only enough liquid to dampen the cloth or applicator.

CLEANING. Loose dust on the outside of the instrument can be removed with a soft cloth or small soft-bristle brush. The brush is particularly useful for dislodging dirt on and around the controls and connectors. Dirt that remains can be removed with a soft cloth dampened in a mild detergent- and-water solution. Do not use abrasive cleaners.

Two plastic light filters, one blue and one clear, are provided with the oscilloscope. Clean the light filters and the CRT face with a soft lint-free cloth dampened with either isopropyl alcohol or a mild detergent-and-water solution.

Interior

To gain access to internal portions of the instrument for inspection and cleaning, refer to the "Removal and Replacement Instructions" in the "Corrective Maintenance" part of this section.

INSPECTION. Inspect the internal portions of the instrument for damage and wear, using Table 6-3 as a guide. Deficiencies found should be repaired immediately. The corrective procedure for most visible defects is obvious; however, particular care must be taken if heat-damaged components are found. Overheating usually indicates other trouble in the instrument, therefore it is important that the cause of overheating be corrected to prevent recurrence of the damage.

If any electrical component is replaced, conduct a Performance Check for the affected circuit and for other closely related circuits (see Section 4). If repair or replacement work is done on any of the power supplies, conduct a complete Performance Check and, if so indicated, an instrument readjustment (see Sections 4 and 5).

Table 6-3
Internal Inspection Check List

Item	Inspect For	Repair Action
Circuit Boards	Loose, broken, or corroded solder connections. Burned circuit boards. Burned, broken, or cracked circuit-run plating.	Clean solder corrosion with an eraser and flush with isopropyl alcohol. Resolder defective connections. Determine cause of burned items and repair. Repair defective circuit runs.
Resistors	Burned, cracked, broken, blistered.	Replace defective resistors. Check for cause of burned component and repair as necessary.
Solder Connections	Cold solder or rosen joints.	Resolder joint and clean with isopropyl alcohol.
Capacitors	Damaged or leaking cases. Corroded solder on leads or terminals.	Replace defective capacitors. Clean solder connections and flush with isopropyl alcohol.
Semiconductors	Loosely inserted in sockets. Distorted pins.	Firmly seat loose semiconductors. Remove devices having distorted pins. Carefully straighten pins (as required to fit the socket), using long-nose pliers, and reinsert firmly. Ensure that straightening action does not crack pins, causing them to break off.
Wiring and Cables	Loose plugs or connectors. Burned, broken, or frayed wiring.	Firmly seat connectors. Repair or replace defective wires or cables.
Chassis	Dents, deformations, and damaged hardware.	Straighten, repair, or replace defective hardware.

CAUTION

To prevent damage from electrical arcing, ensure that circuit boards and components are dry before applying power to the instrument.

CLEANING. To clean the interior, blow off dust with dry, low-pressure air (approximately 9 psi). Remove any remaining dust with a soft brush or a cloth dampened with a solution of mild detergent and water. A cotton-tipped applicator is useful for cleaning in narrow spaces and on circuit boards.

If these methods do not remove all the dust or dirt, the instrument may be spray washed using a solution of 5% mild detergent and 95% water as follows:

CAUTION

Exceptions to the following procedure are the Attenuator assemblies. Clean these assemblies only with isopropyl alcohol as described in step 4.

1. Gain access to the parts to be cleaned by removing easily accessible shields and panels.
2. Spray-wash dirty parts with the detergent-and-water solution, then use clean water to thoroughly rinse them.
3. Dry all parts with low-pressure air.

NOTE

Most of the switches used in the instrument are sealed and the contacts are inaccessible. If cleaning is deemed necessary, use only isopropyl alcohol.

4. Clean switches with isopropyl alcohol and wait 60 seconds for the majority of the alcohol to evaporate. Then complete drying with low-pressure air.
5. Dry all components and assemblies in an oven or drying compartment using low-temperature (125°F to 150°F) circulating air.

LUBRICATION

There is no periodic lubrication required for this instrument.

SEMICONDUCTOR CHECKS

Periodic checks of the transistors and other semiconductors in the oscilloscope are not recommended. The best check of semiconductor performance is actual operation in the instrument.

PERIODIC READJUSTMENT

To ensure accurate measurements, check the performance of this instrument every 2000 hours of operation, or if used infrequently, once each year. In addition, replacement of components may necessitate readjustment of the affected circuits.

Complete Performance Check and Adjustment instructions are given in Sections 4 and 5. The Performance Check Procedure can also be helpful in localizing certain troubles in the instrument.

TROUBLESHOOTING

INTRODUCTION

Preventive maintenance performed on a regular basis should reveal most potential problems before an instrument malfunctions. However, should troubleshooting be required, the following information is provided to facilitate location of a fault. In addition, the material presented in the "Theory of Operation" and "Diagrams" sections of this manual may be helpful while troubleshooting.

TROUBLESHOOTING AIDS

Diagnostic Firmware

The operating firmware in this instrument contains diagnostic routines that aid in locating malfunctions. When instrument power is applied, power-up tests are performed to verify proper operation of much of the instrument's circuitry. If a failure is detected, this information is passed on to the operator in the form of either a CRT readout or illuminated LED indicators. The failure information directs the operator to the failing block of circuitry. If the failure is such that the processor can still execute the diagnostic routines, the user can call up specific tests to further check the failing circuitry. The specific diagnostic routines are explained later in this section.

Schematic Diagrams

Complete schematic diagrams are located on tabbed foldout pages in the "Diagrams" section. Portions of circuitry mounted on each circuit board are enclosed by heavy black lines. The assembly number and name of the circuit are shown near either the top or the bottom edge of the diagram.

Functional blocks on schematic diagrams are outlined with a wide grey line. Components within the outlined area perform the function designated by the block label. The "Theory of Operation" uses these functional block names when describing circuit operation as an aid in cross-referencing between the theory and the schematic diagrams.

Component numbers and electrical values of components in this instrument are shown on the schematic diagrams. Refer to the first page of the "Diagrams" section for the reference designators and symbols used to identify components. Important voltages and waveform reference numbers (enclosed in hexagonal-shaped boxes) are also shown on each diagram. Waveform illustrations are located adjacent to their respective schematic diagram.

Circuit Board Illustrations

Circuit board illustrations showing the physical location of each component are provided for use in conjunction with each schematic diagram. Each board illustration is found in the "Diagrams" section on the back of a foldout page, preceding the first schematic diagram(s) to which it relates.

The locations of waveform test points are marked on the circuit board illustrations with hexagonal outlined numbers corresponding to the waveform numbers on both the schematic diagram and the waveform illustrations.

Circuit Board Locations

The placement in the instrument of each circuit board is shown in a board locator illustration. This illustration is located on the foldout page along with the circuit board illustration.

Power Distribution Diagrams

Power Distribution diagrams (diagrams 11 and 12) are provided in the "Diagrams" section to aid in troubleshooting power-supply problems.

Circuit Board Interconnection Diagram

A circuit board interconnection diagram (diagram 13) and tables listing the interconnecting pins and signals carried are provided in the "Diagrams" section following the Power Distribution diagrams.

Grid Coordinate System

Each schematic diagram and circuit board illustration has a grid border along its left and top edges. A table located adjacent to each diagram lists the grid coordinates of each component shown on that diagram. To aid in physically locating components on the circuit board, this table also lists the grid coordinates of each component on the circuit board illustration.

Near each circuit board illustration is an alphanumeric listing of all components mounted on that board. The second column in each listing identifies the schematic diagram on which each component can be found. These component-locator tables are especially useful when more than one schematic diagram is associated with a particular circuit board.

Troubleshooting Charts

The troubleshooting charts contained in the "Diagrams" section are to be used as an aid in locating malfunctioning circuitry. To use the charts, begin with the Preliminary Tests flowchart. This chart will help identify problem areas and will direct you to other appropriate charts for further troubleshooting.

Some malfunctions, especially those involving multiple simultaneous failures, may require more elaborate troubleshooting approaches with references to circuit descriptions in the "Theory of Operation" section of this manual.

Component Color Coding

Information regarding color codes and markings of resistors and capacitors is located on the color-coding illustration (Figure 9-1) at the beginning of the "Diagrams" section.

RESISTOR COLOR CODE. Resistors used in this instrument are carbon-film, composition, or precision metal-film types. They are usually color coded with the EIA color code; however, some metal-film type resistors may have the value printed on the body. The color code is interpreted starting with the stripe nearest to one end of the resistor. Composition resistors have four stripes; these represent two significant digits, a multiplier, and a tolerance value. Metal-film resistors have five stripes representing three significant digits, a multiplier, and a tolerance value.

CAPACITOR MARKINGS. Capacitance values of common disc capacitors and small electrolytics are marked on the side of the capacitor body. White ceramic capacitors are color coded in picofarads, using a modified EIA code.

Dipped tantalum capacitors are color coded in microfarads. The color dot indicates both the positive lead and the voltage rating. Since these capacitors are easily destroyed by reversed or excessive voltage, be careful to observe the polarity and voltage rating when replacing them.

DIODE COLOR CODE. The cathode end of each glass-encased diode is indicated by either a stripe, a series of stripes or a dot. For most diodes marked with a series of stripes, the color combination of the stripes identifies three digits of the Tektronix Part Number, using the resistor color-code system. The cathode and anode ends of a metal-encased diode may be identified by the diode symbol marked on its body.

Semiconductor Lead Configurations

Figure 9-2 in the "Diagrams" section shows the lead configurations for semiconductor devices used in the instrument. These lead configurations and case styles are typical of those used at completion of the instrument design. Vendor changes and performance improvement changes may result in changes of case styles or lead configurations. If the device in question does not appear to match the configuration shown in Figure 9-2, examine the associated circuitry or consult a manufacturer's data sheet.

Multipin Connectors

Multipin connector orientation is indexed by a triangle on the cable connector and a 1 or triangle on the circuit board. Slot numbers may be molded into the connector. When a connection is made to circuit board pins or header, ensure that the index on the connector is aligned with the index on the circuit board (see Figure 6-1). Cable connectors can be removed by inserting a screw driver into the center slot of its header.

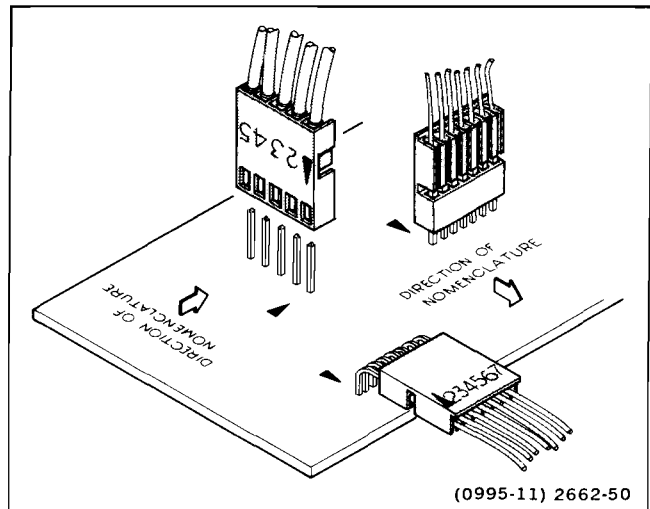

Figure 6-1. Multipin connector orientation.

TROUBLESHOOTING EQUIPMENT

The equipment listed in Table 4-1 of this manual, or equivalent equipment, may be useful when troubleshooting this instrument.

TROUBLESHOOTING TECHNIQUES

The following procedure is arranged in an order that enables checking simple trouble possibilities before requiring more extensive troubleshooting. The first two steps

use diagnostic aids inherent in the instrument's operating firmware and will locate many circuit faults. The next four procedures are check steps that ensure proper control settings, connections, operation, and adjustment. If the trouble is not located by these checks, the remaining steps will aid in locating the defective component. When the defective component is located, replace it using the appropriate replacement procedure given under "Corrective Maintenance" in this section.

CAUTION

Before using any test equipment to make measurements on static-sensitive, current-sensitive, or voltage-sensitive components or assemblies, ensure that any voltage or current supplied by the test equipment does not exceed the limits of the component to be tested.

1. Power-up Tests

The instrument performs automatic verification of much of the instrument's circuitry when power is first applied. The Kernel tests verify proper operation of the Microprocessor, the ROM, and the RAM. If all Kernel tests pass, a second level of checks, the Confidence tests, are performed. The Confidence tests, when passed, give the user a high degree of assurance that the instrument is functioning properly.

If a Kernel test or Confidence test fails, the area of failure is identified either by a message on the CRT (if the instrument is able to produce a display) or by an error code displayed on the front-panel LED indicators. If a failure occurs, refer to the "Diagnostic Routines" discussion later in this section for definitions of error messages and LED error codes.

Once a problem area has been identified, the associated troubleshooting procedure should be performed to further isolate the problem. The troubleshooting procedures are located on tabbed-foldout pages in the "Diagrams" section at the rear of this manual.

2. Diagnostic Test and Exerciser Routines

Each of the tests automatically performed at power-up, along with several other circuit exercising routines, may be individually selected by the user to further clarify the nature of a suspected failure. The desired test or exerciser is selected by scrolling through a menu of the available routines when under control of the Diagnostic Monitor. Entry into the Diagnostic Monitor and its uses are explained in the "Diagnostic Routines" discussion later in this section.

3. Check Control Settings

Incorrect control settings can give a false indication of instrument malfunction. If there is any question about the correct function or operation of any control, refer to the Operators Manual.

4. Check Associated Equipment

Before proceeding, ensure that any equipment used with the instrument is operating correctly. Verify that input signals are properly connected and that the interconnecting cables are not defective. Check that the ac-power-source voltage to all equipment is correct.

5. Visual Check

Perform a visual inspection. This check may reveal broken connections or wires, damaged components, semiconductors not firmly mounted, damaged circuit boards, or other clues to the cause of an instrument malfunction.

6. Check Instrument Performance and Adjustment.

Check the performance of either those circuits where trouble appears to exist or the entire instrument. The apparent trouble may be the result of misadjustment. Complete performance check and adjustment instructions are given in Sections 4 and 5 of this manual.

7. Isolate Trouble to a Circuit

To isolate problems to a particular area, use any symptoms noticed to help locate the trouble. Refer to the trouble-shooting charts in the "Diagrams" section as an aid in locating a faulty circuit.

When trouble symptoms appear in more than one circuit, first check the power supplies, then check the affected circuits by taking voltage and waveform readings. Check first for the correct output voltage of each individual supply. These voltages are measured between the power supply test points and ground. (See schematic diagrams 8, 9, 10, and associated circuit board illustrations in the "Diagrams" section.) If the power-supply voltages and ripple are within the listed ranges, the supply can be assumed to be working correctly. If they are outside the range, the supply may be either misadjusted or operating incorrectly.

The Low Voltage Power Supply levels are interdependent. All the low voltage supplies use the +10 V reference for their reference levels. If more than one of the low voltage supplies appears defective, repair them in the following order: +10 V REF, +5 V Digital, +87 V, +42 V, +15 V, +5 V Analog, -15 V, -8 V, and -5 V.

A defective component elsewhere in the instrument can create the appearance of a power-supply problem and may also affect the operation of other circuits. Use the power supply troubleshooting charts to aid in locating the problem.

8. Check Circuit Board Interconnections

After the trouble has been isolated to a particular circuit, again check for loose or broken connections, improperly seated semiconductors, and heat-damaged components.

9. Check Voltages and Waveforms

Often the defective component can be located by checking circuit voltages or waveforms. Typical voltages are listed on the schematic diagrams. Waveforms indicated on the schematic diagrams by hexagonal-outlined numbers are shown adjacent to the diagrams. Waveform test points are shown on the circuit board illustrations.

NOTE

Voltages and waveforms indicated on the schematic diagrams are not absolute and may vary slightly between instruments. To establish operating conditions similar to those used to obtain these readings, see the voltage and waveform setup conditions preceding the waveform illustrations.

Note the recommended test equipment, front-panel control settings, voltage and waveform conditions, and cable-connection instructions. Any special control settings required to obtain a given waveform are noted under the waveform illustration. Changes to the control settings from the initial setup, other than those noted, are not required.

10. Check Individual Components

The following procedures describe methods of checking individual components. Two-lead components that are soldered in place are most accurately checked by first disconnecting one end from the circuit board. This isolates the measurement from the effects of the surrounding circuitry. See Figure 9-1 for component value identification and Figure 9-2 for semiconductor lead configurations.

WARNING

To avoid electric shock, always disconnect the instrument from the ac power source before removing or replacing components.

CAUTION

When checking semiconductors, observe the static-sensitivity precautions located at the beginning of this section.

TRANSISTORS. A good check of a transistor is actual performance under operating conditions. A transistor can most effectively be checked by substituting a known-good component. However, be sure that circuit conditions are not such that a replacement transistor might also be damaged. If substitute transistors are not available, use a dynamic-type transistor checker for testing. Static-type transistor checkers are not recommended, since they do not check operation under simulated operating conditions.

When troubleshooting transistors in the circuit with a voltmeter, measure both the emitter-to-base and emitter-to-collector voltages to determine whether they are consistent with normal circuit voltages. Voltages across a transistor may vary with the type of device and its circuit function.

Some of these voltages are predictable. The emitter-to-base voltage for a conducting silicon transistor will normally range from 0.6 V to 0.8 V. The emitter-to-collector voltage for a saturated transistor is about 0.2 V. Because these values are small, the best way to check them is by connecting a sensitive voltmeter across the junction rather than comparing two voltages taken with respect to ground. If the former method is used, both leads of the voltmeter must be isolated from ground.

If voltage values measured are less than those just given, either the device is shorted or no current is flowing in the external circuit. If values exceed the emitter-to-base values given, either the junction is reverse biased or the device is defective. Voltages exceeding those given for typical emitter-to-collector values could indicate either a nonsaturated device operating normally or a defective (open-circuited) transistor. If the device is conducting, voltage will be developed across the resistors in series with it; if open, no voltage will be developed across the resistors unless current is being supplied by a parallel path.

CAUTION

When checking emitter-to-base junctions, do not use an ohmmeter range that has a high internal current. High current may damage the transistor. Reverse biasing the emitter-to-base junction with a high current may degrade the current-transfer ratio (Beta) of the transistor.

A transistor emitter-to-base junction also can be checked for an open or shorted condition by measuring the resistance between terminals with an ohmmeter set to a range having a low internal source current, such as the $R \times 1 \text{ k}\Omega$ range. The junction resistance should be very high in one direction and much lower when the meter leads are reversed.

When troubleshooting a field-effect transistor (FET), the voltage across its elements can be checked in the same manner as previously described for other transistors. However, remember that in the normal depletion mode of operation, the gate-to-source junction is reverse biased; in the enhanced mode, the junction is forward biased.

INTEGRATED CIRCUITS. An integrated circuit (IC) can be checked with a voltmeter, test oscilloscope, or by direct substitution. A good understanding of circuit operation is essential when troubleshooting a circuit having IC components. Use care when checking voltages and waveforms around the IC so that adjacent leads are not shorted together. An IC test clip provides a convenient means of clipping a test probe to an IC.

HYBRIDS. Hybrid components can best be checked by observing voltages and waveforms on the circuit board. Measurements should not be made on any hybrid component while out of the circuit as they may easily be damaged. Direct substitution is the best troubleshooting method when a hybrid failure is suspected. The CH 1 and CH 2 hybrids are matched, and should be replaced as a matched pair.

CAUTION

When checking a diode, do not use an ohmmeter scale that has a high internal current. High current may damage a diode. Checks on diodes can be performed in much the same manner as those on transistor emitter-to-base junctions. Do not check tunnel diodes or back diodes with an ohmmeter; use a dynamic tester, such as the TEKTRONIX 576 Curve Tracer.

DIODES. A diode can be checked for either an open or a shorted condition by measuring the resistance between terminals with an ohmmeter set to a range having a low internal source current, such as the $R \times 1 \text{ k}\Omega$ range. The diode resistance should be very high in one direction and much lower when the meter leads are reversed.

Silicon diodes should have 0.6 to 0.8 V across their junctions when conducting. Higher readings indicate that they are either reverse biased or defective, depending on polarity.

Light Emitting Diodes (LEDs) should have 1.5 to 2.2 V, depending on their current and color, across their junctions when conducting. Higher readings usually indicate the diodes are open, especially if they are not illuminated (ON).

RESISTORS. Check resistors with an ohmmeter. Refer to the "Replaceable Electrical Parts" list for the tolerances of resistors used in this instrument. A resistor normally does not require replacement unless its measured value varies widely from its specified value and tolerance.

INDUCTORS. Check for open inductors by checking continuity with an ohmmeter. Shorted or partially shorted inductors can usually be found by checking the waveform response when high-frequency signals are passed through the circuit.

CAPACITORS. A leaky or shorted capacitor can best be detected by checking resistance with an ohmmeter set to one of the highest ranges. Do not exceed the voltage rating of the capacitor. The resistance reading should be high after the capacitor is charged to the output voltage of the ohmmeter. An open capacitor can be detected with a capacitance meter or by checking whether the capacitor passes ac signals.

ATTENUATORS. The Attenuators are built as complete assemblies and should not be taken apart. If an Attenuator is suspected as having failed, direct substitution is the recommended troubleshooting method.

11. Repair and Adjust the Circuit.

If any defective parts are located, follow the replacement procedures given under "Corrective Maintenance" in this section. After any electrical component has been replaced, the performance of that circuit and any other closely related circuit should be checked. Since the power supplies affect all circuits, performance of the entire instrument should be checked if work has been done on the power supplies or if the power transformer has been replaced. Readjustment of the affected circuitry may be necessary. Refer to the "Performance Check" and "Adjustment Procedure", Sections 4 and 5 of this manual.

DIAGNOSTIC ROUTINES

The diagnostic routines contained in the instrument operating firmware consist of the various power-up tests, automatically performed when power is first applied, and several circuit exerciser routines. The test or exerciser routines are selected by scrolling through a menu of available routines when the firmware is under control of the Diagnostic Monitor. Monitor control is indicated by the message "DIAGNOSTIC. PUSH A/B TRIG TO EXIT" displayed in the top CRT graticule division.

Maintenance—2445A/2455A Service

Entry into the monitor is automatic if a power-up test fails. The user may also force entry into the Diagnostic Monitor from the normal operating mode by holding in the front-panel ΔV and Δt push buttons and then pressing the front-panel SLOPE push button. Exiting the monitor is accomplished by pressing in the A/B TRIG push button, as instructed by the CRT readout display.

Depending on how the Diagnostic Monitor was entered (from normal mode or as a result of a power-up test failure), the first menu item displayed may vary; entry into

the monitor from the normal mode begins at ALL TESTS while entry from power-up starts at the first failed test. Since, in a failure mode, the CRT readout may not be able to display the selected menu item, the VERT TRIGGER SOURCE indicator illuminates as a reference when ALL TESTS is selected. With the VERT TRIGGER SOURCE indicator illuminated, the user may scroll to the desired test or exerciser routine using the test order called out in Table 6-4 or Table 6-5 respectively. Whether the menu is displayed or not, scrolling is accomplished by pressing either the front-panel upper TRIGGER MODE switch to increment or the lower TRIGGER MODE switch to decrement the menu position by one.

Table 6-4
Sequence of Diagnostic Tests

Routine Type	Type Number	ON LED	Routine Name	Error Code	Error Code Meaning
All Tests ^a	00	VERT	All	ZZ	The left digit is the option number and the right digit is the test number of the first failing test of the last ALL TESTS run. When looping, it shows the last failing test.
Test	01	CH 1	Interrupt Request	01	Interrupt request is missing or has wrong period.
Test	02	CH 2	Switch Stuck	01 02 04 05 11 12 13 14 15 25 31 32 33 34 35 41 42 43 44 45 51 52 53 54 55 61 62 63 64 65 ^b	Trigger COUPLING lower. Trigger COUPLING upper. CH 1 Coupling lower. CH 1 Coupling upper. CH 4 VOLTS/DIV CH 3 VOLTS/DIV INIT @ 50% CH 2 Coupling lower. CH 2 Coupling upper. CH 2 INVERT CH 1 VERTICAL MODE CH 2 VERTICAL MODE ADD VERTICAL MODE CH 3 VERTICAL MODE CH 4 VERTICAL MODE STEP/AUTO SAVE HELP RECALL HELP CHOP/ALT VERTICAL MODE 20 MHz BW LIMIT X10 MAG TRACK/INDEP Δt (delta time). ΔV (delta volts). Trigger SLOPE Trigger SOURCE lower. Trigger SOURCE upper. Trigger MODE lower. Trigger MODE upper. A/B TRIG select.
Test	03	CH 3	Readout	01 02	Shift register failure ^c (– Trigger LED). Readout RAM failure ^c (+ Trigger LED).

Table 6-4 (cont)

Routine Type	Type Number	ON LED	Routine Name	Error Code	Error Code Meaning
Test	04	CH 4	Calibration Data	X1	Parity error on read (bit 0 set).
				X2	Out of limits (bit 1 set).
				1X	Bad checksum (bit 4 set).
Test	05	ADD	Main Board	01	AUTO LVL failed to trigger.
				X2	Negative level not negative enough.
				X4	Negative level too negative.
				2X	Positive level not positive enough.
				4X	Positive level too positive.
Test	06	INVERT	RAM Battery	01	Battery voltage too low.
				02	Battery voltage too high.

*VERT TRIG SOURCE indicator lights when in ALL TESTS as a visual reference in the event a CRT display can not be produced.

^bIf the A/B TRIG switch is stuck during power-up, the oscilloscope will branch to “normal” operation after a short delay. The associated error message will only be visible momentarily if the CRT is warmed up.

^cReadout Board error codes are also displayed on the + and – Trigger SLOPE LEDs.

Table 6-5
Sequence of Exerciser Routines^a

Routine Type	Type Number	ON LED
Exerciser 01	CH 1	Display Pots and Switches
Exerciser 02	CH 2	Examine Calibration Data in RAM
Exerciser 03	CH 3	Clears Cycle Errors
Exerciser 04	CH 4	Display ROM Headers
Exerciser 05	ADD	Display Operating Time and Power Cycle Count
Exerciser 06	INVERT	Select Setup to Use at Power-Up
Exerciser 07	CHOP	Enable/Disable Setup SAVE and Sequence Definition
Exerciser 08	BW LIMIT	Initialize Setups

^aAdditional Diagnostic Exercisers for extended functions are in Appendix A of the Operators Manual.

Routine Control

When the desired Test or Exerciser has been selected, the operator has two types of control that may be exercised over the routine: START/STOP and LOOP.

Starting or stopping the execution of the selected routine is controlled by the front-panel TRIGGER COUPLING switches. Pressing the upper switch starts the routine; pressing the lower switch stops it.

All of the test routines may be set to LOOP mode (continuously repeated) by pressing the front-panel upper TRIGGER SOURCE switch while the routine is selected but not executing. The LOOP feature will cause the routine to be continuously repeated once started until stopped when the operator presses the lower TRIGGER COUPLING switch. Once the routine is stopped, the LOOP feature may be disabled by pressing the lower TRIGGER SOURCE switch.

While a Test or Exerciser routine is executing, the Diagnostic Monitor Control message on the top line of the CRT display will be cleared as an indication that a routine is running. When test routines are looping, the message “LOOP” is displayed in the bottom division of the CRT graticule.

Display Format

The Tests and Exercisers routines display information about the routine type and number, as well as any test results, at the bottom of the CRT display. The readout line is formatted as follows:

OD TYPE XY STATUS ZZ LOOP OD<ABCC>

The information is defined as follows:

“OD” is a two-character option designator identifying the option that this particular line of diagnostic information refers to (see Options manual for details). For the basic instrument, the OD location is blank.

“TYPE” refers to routine type: All Tests (ALL), Test (TEST), Exerciser (EXER), or Calibration (CAL).

“X” indicates which bit of the “Option Select Register” is set to turn on the option called out by “OD” (see Options manual for description of Options Select Register). This bit is zero for the basic instrument.

“Y” is the TYPE number of the routine (see the “Type Number” column of Table 6-4).

“STATUS” shows the results of the last time a selected test routine ran: either PASS or FAIL. This space is blank for exerciser and calibration routines. When the diagnostics are called up from normal operating mode, the space will be blank until the selected test is executed.

“ZZ” is a two-digit error code identifying the nature of the failure in a failed test (see the “Error Code” column of Table 6-4).

“LOOP” indicates when a selected test is set to the LOOP mode.

“OD<ABCC>” is the CYCLE mode failure indicator. CYCLE mode, when entered by removing the NO CAL/CAL jumper (P501) before turning the instrument on, causes the instrument to continuously LOOP through the Power Up Diagnostic Tests. If a failure occurs, the cycle-failure data, identifying the first failure encountered, is written to RAM. Thereafter, at each power-up, the Diagnostic Monitor is automatically entered, and the failure data is displayed. The failure data must be cleared from the RAM location to eliminate the CYCLE mode failure display (see CYCLE ERROR CLEAR Exerciser 03). The information displayed is an abbreviated version of the previous items:

“OD” is a two-character option designator showing which option failed first while in the CYCLE mode (the same codes as for “OD” at the start of the readout line).

“A” identifies the option-select bit for the failing option (the same code as for “X”).

“B” is the test Type Number where the failure occurred (the same codes as for “Y”).

“CC” is the error code for the test (the same codes as for “ZZ”).

Kernel Tests

The Kernel tests are those tests which, when failed, are considered “fatal” to the operation of the Microprocessor. Failure of a Kernel test will cause the front-panel TRIG'D indicator to flash, and certain of the other front-panel indicators will be illuminated with an error code. The code points to the area of failure as indicated in Table 6-6. Tables 6-7 and 6-8 are used to determine the option and device numbers used in Table 6-6. Only the basic instrument codes are given in Table 6-6. Option codes are defined in the “Options Service Manual.”

**Table 6-6
Kernel Test Failure Codes**

Failure Codes		
Option	Device	Failing Device
0	0	Control Board RAM
0	1	ROM U2160
0	2	ROM U2260

**Table 6-7
Front-Panel LED Option Codes**

Option Code				Option Number (in Hex)	Option Name
CH 1 LED (bit 3)	CH 2 LED (bit 2)	CH 3 LED (bit 1)	CH 4 LED (bit 0)		
OFF	OFF	OFF	OFF	0	Basic Instrument
ON	ON	ON	ON	F	Options Buffer Board

Table 6-8
Front-Panel LED Device Codes

READY LED (bit 2)	Device Code		Device Number
	+ LED (bit 1)	- LED (bit 0)	
OFF	OFF	OFF	0
OFF	OFF	ON	1
OFF	ON	OFF	2
OFF	ON	ON	3
ON	OFF	OFF	4
ON	OFF	ON	5
ON	ON	OFF	6
ON	ON	ON	7

Even if a Kernel test fails, the operator may try to go to normal oscilloscope operation by pressing the A/B TRIG select push button. Depending on the exact nature of the failure, the instrument may or may not be functional.

Kernel tests are automatically executed at power-up. The Kernel tests are divided into RAM tests and ROM tests as follows:

RAM TEST. This test is done with a complementary data pattern starting at the highest RAM address available and continuing to the lowest. The process reads and saves the original data, and then writes a pattern of 01010101's (55 Hex) at the highest RAM memory address. The data is then read back to see if it is still 55 (Hex). Next a complementary pattern of 10101010 (AA Hex) is written to the same address. Then the address content is read back and tested to see if it is still AA (Hex). After the memory is checked, the original data is written back into the memory address. RAM TEST then checks the next lower address. The testing continues until all of RAM is checked.

Test checks: RAM address decoding, RAM address lines, RAM data lines, RAM memory, and Data Bus Buffers.

ROM TEST. The ROM test performs three checks on each of the system read-only memories.

Data Bus Drive—Two locations containing complementary data patterns are read.

Test checks: Data bus lines and the Data Bus Driver.

Correct Part—A byte in the ROM being checked is compared to the most-significant byte of the addressed ROM block (starting address of where the ROM should be installed).

Test checks: ROM address decoding and proper installation of ROM components.

Checksum—A sixteen bit, spiral-add checksum is calculated and compared to a two-byte value stored in ROM being checked.

Test checks: ROM contents, ROM addressing, ROM data lines, and the Data Bus Driver.

Confidence Tests

The Confidence tests provide checks for much of the remaining circuitry to ensure that instrument operation is correct. Confidence tests are performed automatically at power-up after the Kernel is determined to be functional or initiated by the operator from the Diagnostic Monitor.

A failure of any Confidence test during power-up will pass control to the Diagnostic Monitor; this permits the test results to be examined. Descriptions of the Confidence tests follow.

INTERRUPT REQUEST (Test 01). Ten consecutive interrupt cycles are checked to ensure that succeeding interrupts occur not more than 4.5 ms apart (5600 "E" cycles).

Test checks: Interrupt Timer circuitry.

SWITCH STUCK (Test 02). The front-panel, momentary-contact switches are scanned, checking for a closed switch. At power-up, the test runs immediately.

By holding one of the momentary switches in a closed position when power is first applied, this test will fail, and the Diagnostic Monitor will be entered. When the test is started from the Diagnostic Monitor, a one-half second delay is incorporated to allow the COUPLING (test start) switch to return to its normal (open) position. Table 6-4 defines the error codes that may be encountered when a switch is detected as closed.

NOTE

When pressing the lower TRIGGER COUPLING switch to stop this test, an error code may be generated. This is normal and does not indicate an actual failure.

Test checks: Momentary switches, row scanning circuitry, and column scanning circuitry.

READOUT BOARD (Test 03). This two-part test checks the interface to the Readout Board from the Microprocessor and the character RAM circuits.

Processor Interface Test—The Microprocessor loads the three, eight-bit shift registers with an alternating bit pattern that is then shifted back to the processor for comparison.

Test checks: Data Registers, data strobes (clocks), and the data input and output lines.

RAM Test—A "1" is rotated through each byte of the Readout RAM, one bit at a time. Each time an additional bit is rotated into the byte, the byte is loaded into the processor interface and clocked back to the processor for comparison. The byte is then restored to its original content, and each successive byte is tested in the same manner.

Test checks: Readout RAM addressing, Readout RAM data lines, and RAM read/write capability.

CALIBRATION DATA (Test 04). Three checks are performed on the RAM to verify its contents.

Checksum Test—The contents of locations containing calibration constants are checksummed using a spiral-add technique. The result is compared to the stored checksum generated at the time of calibration.

Test checks: RAM addressing and RAM contents.

Parity Test—As each of the calibration constants is read for the Checksum test above, the parity of each 14-bit word is checked.

Test checks: CALIBRATION DATA integrity and RAM CALIBRATION DATA retention.

Limit Test—Checks for valid calibration data.

Test checks: The contents of locations containing calibration data are compared to their stored limits.

MAIN BOARD (Test 05). The AUTO LVL triggering feature (a routine stored in firmware) is operated to detect the peaks of a Line Trigger signal. Detected peaks are compared to expected values to verify operation (and calibration) of interrelated signal processing circuits.

Test checks: Line Trigger source, the A-Trigger generation circuitry, and Control DAC U2101 (located on the Control board, diagram 2).

BATTERY VOLTS (Test 06). The battery voltage is read and compared to stored constants. If the voltage is above or below the stored limits the appropriate error code is displayed.

Test checks: Battery voltage, voltage follower operational amplifier U2620C, and CR2770.

Exerciser Routines

The Exerciser routines (see Table 6-5) allow the operator to set and examine various bytes of control data used in determining instrument function.

POTS AND SWITCHES (Exerciser 01). This routine displays the values that the Microprocessor detects as the various digitized pots and switches are activated. The left half of the top line of the display appears after turning a pot. The right half of the top line of the CRT display appears after pressing a switch. The top line of the CRT display has the following format:

AA BB CC DEEE FF GG HI JJ KL

The format is defined as follows:

"AA" is the code of the most-recently-activated potentiometer (see Table 6-9 for definition of pot codes).

"BB" is the current value (in hexadecimal) of pot AA. See Table 6-9 for the approximate range of codes for the CCW (counter clockwise) and CW (clockwise) potentiometer rotations.

Maintenance—2445A/2455A Service

“CC” is the previous value (in hexadecimal) of pot AA.

“D” is the DAC Multiplexer code used to select pot AA (see Table 6-9).

“EEE” is the 12-bit DAC value (in hexadecimal) associated with pot AA. See Table 6-9 for the approximate range of codes for the CCW (counter clockwise) and CW (clockwise) potentiometer rotations.

“FF” is the code of the previously-activated potentiometer (see Table 6-9).

“GG” is the row code of the most-recently-activated switch (see Table 6-10 for definition of row codes).

“H” is the switch-position code: 0 for open; C for closed.

“I” is the column code of the most-recently-activated switch (see Table 6-10).

“JJ” is the row code for the previously-activated switch.

“K” is the switch-position code: 0 for open; C for closed.

“L” is the column code for the previously-activated switch.

NOTE

For all momentary switches (except A/B TRIG) only the closed position will be shown in the switch-position code locations (H and K). The A/B TRIG switch has both the open and the closed positions shown.

**Table 6-9
Potentiometer Codes and Values (Exerciser 01)**

Rotation Values				Potentiometer	
CCW		CW		AA	Name
BB	DEEE	BB	DEEE	Code	
FF	6FFF	00	6000	01	HOLDOFF
FF	3FFF	00	3000	02	Trigger LEVEL
00	1000	FF	1FFF	03	SEC/DIV VAR
FF	5FFF	00	5000	04	Horizontal POSITION
00	0000	FF	3FFF	05	Δ (A section) ^a
00	0000	FF	3FFF	06	Δ (B section) ^a
00	0000	FF	3FFF	07	Δ REF OR DLY POS (A section) ^a
00	0000	FF	3FFF	08	Δ REF OR DLY POS (B section) ^a
FF	07FF	00	0000	09	CH 1 VOLTS/DIV VAR
FF	27FF	00	2000	0A	CH 2 VOLTS/DIV VAR
FF	0FFF	00	0000	11	CH 1 Vertical POSITION
FF	1FFF	00	1000	12	CH 2 Vertical POSITION
FF	27FF	00	2000	13	CH 3 Vertical POSITION
FF	37FF	00	3000	14	CH 4 Vertical POSITION
FF	4FFF	00	4800	15	TRACE SEP
FF	5FFF ^b	00	5FFF ^b	16	READOUT INTENSITY
80	6800	FF	6FFF	17	Trace INTENSITY

^aThe Δ REF OR DLY POS and Δ controls are both 180° offset pairs that continuously rotate. Displayed BB values jump and the AA code changes when instrument software switches between the A and B sections. The D code position shows the two most-significant bits of the 14-bit DAC output (in hexadecimal), effectively generating 5.5 turn potentiometer values.

^bThe potentiometer midpoint value is 5800, and the intensity is off (MIN). Maximum intensity is at both the CCW and CW positions.

Table 6-10
Pots and Switches Column
and Row Code Definitions (Exerciser 01)

Row	Column	Definition	Row	Column	Definition
Code (GG)	Code (I)		Code (GG)	Code (I)	
0	0	Trig COUPLING Down	5	0	Unused
0	1	Trig COUPLING Up	5	1	Unused
0	2	READOUT Scale Factors	5	2	Unused
0	3	CH 1 Coupling Down	5	3	Unused
0	4	CH 1 Coupling Up	5	4	Unused
1	0	CH 4 VOLTS/DIV	6	0	CH 1 VERT MODE
1	1	CH 3 VOLTS/DIV	6	1	CH 2 VERT MODE
1	2	INIT@50%	6	2	ADD VERT MODE
1	3	CH 2 Coupling Down	6	3	CH 3 VERT MODE
1	4	CH 2 Coupling Up	6	4	CH 4 VERT MODE
2	0	CH 1 VOLTS/DIV LSB	7	0	STEP/AUTO
2	1	CH 1 VOLTS/DIV Bit 2	7	1	SAVE HELP
2	2	CH 1 VOLTS/DIV Bit 3	7	2	RECALL HELP
2	3	CH 1 VOLTS DIV MSB	7	3	CHOP/ALT
2	4	CH 2 INVERT	7	4	BW LIMIT
3	0	CH 2 VOLTS/DIV LSB	8	0	X10 MAG
3	1	CH 2 VOLTS/DIV Bit 2	8	1	TRACKING/INDEP
3	2	CH 2 VOLTS/DIV Bit 3	8	2	Δt
3	3	CH 2 VOLTS/DIV MSB	8	3	ΔV
3	4	B ENDS A	8	4	Trig SLOPE
4	0	SEC/DIV LSB	9	0	Trig SOURCE Down
4	1	SEC/DIV Bit 2	9	1	Trig SOURCE Up
4	2	SEC/DIV Bit 3	9	2	Trig MODE Down
4	3	SEC/DIV MSB	9	3	Trig MODE Up
4	4	A/B SWP Select	9	4	A/B TRIG/MENU Select

CALIBRATION RAM EXAMINE (Exerciser 02). This routine allows the operator to examine the contents of 256 decimal locations, 00 (Hex) through FF (Hex), in RAM. When entered, the Exerciser displays the contents of RAM location 00 (Hex) on the top line of the CRT display. One hundred and seventy calibration constants reside between addresses 01 (Hex) and AA (Hex). Calibration constants residing between 01 (Hex) and 6E (Hex) should have odd parity as explained below. The remaining locations may be of either parity. The readout display line has the following format:

AA DDDD P

The format is defined as follows:

“AA” is the eight-bit address in hexadecimal notation.

“DDDD” is the 14-bit word stored at that location (13 bits of data and one parity bit).

“P” is a parity indicator for the data word: X indicates even parity; blank is odd parity.

Pushing the upper or lower TRIGGER MODE switch will increment or decrement the RAM address by 16 (10 Hex) respectively. Similarly, pushing the upper or lower TRIGGER SOURCE switch will increment or decrement the address by 1 respectively.

Maintenance—2445A/2455A Service

CYCLE ERROR CLEAR (Exerciser 03). This routine provides a way to clear the cycle-failure data written to the RAM when a CYCLE mode failure occurs. Interpretation of the cycle failure data is explained in the "Display Format" description provided earlier in this section. Until the data is cleared, each time the instrument is powered up, the Diagnostic Monitor is entered.

Clearing the RAM location (and the CYCLE ERROR message) is done by scrolling to EXER 03 (CLEAR CYCLE ERROR) and pressing the following switches in sequence:

TRIGGER COUPLING upper (starts exerciser),
TRIGGER SOURCE lower,
TRIGGER MODE lower, then
TRIGGER COUPLING lower (exits the exerciser).

When the CYCLE ERROR CLEAR routine is successfully executed, the cycle failure data will disappear from the display.

DISPLAY ROM HEADERS (Exerciser 04). This routine displays the Standard Tektronix ROM Header of each system ROM on the top line of the CRT display. The readout line has the following format:

CCCC PPPP SS AAAA OD

The definition of the format is as follows:

"CCCC" is a two-byte hexadecimal checksum.

"PPPP" is the four middle digits of the ROM part number.

"SS" is the suffix of the ROM part number (version number).

"AAAA" is the starting address of the ROM (address where the ROM should be installed).

"OD" is a two-character option designator identifying the option that this particular line of diagnostic information refers to (see Options manual for details). For the basic instrument, the OD location is blank.

Pressing the upper TRIGGER COUPLING switch increments the routine to the next ROM Header; pressing the lower TRIGGER COUPLING switch exits the routine.

HRS ON and OFF/ON CYCLES (Exerciser 05). This routine displays the Operating Time and Power Cycle Count (see Operators Manual).

POWER-UP SETUP (Exerciser 06). This routine selects the setup to use at power-up (see Operators Manual).

SAVE ENABLE (Exerciser 07). This routine will Enable/Disable setup SAVE and sequence definition (see Operators Manual).

SETUP INIT (Exerciser 08). This routine destroys all saved setups (see Operators Manual).

CONTROLLER LATCHES EXERCISER. This routine is not user selectable, but runs automatically when the Diagnostic Monitor is waiting for a key activation.

The routine first sets latches U2301 and U2201 (diagram 2). It then pulses the B SWP CLK line (pin 13 of U2660, diagram 1), as a scope trigger, and rotates a "0" through 15 of the 16 latched bits. Bit 16 is not set since it would reset Interrupt Timer U2640 (diagram 1) and upset processor interrupt timing. By externally triggering a test oscilloscope on the B SWP CLK signal line and observing the shifted timing relationships of the latched signals, proper operation of the DAC latches may be verified.

NOP KERNEL EXERCISER. This exerciser is not a firmware routine, but rather a forced hardware condition. It is best suited for troubleshooting an inoperative Control Board, as it exercises only the Microprocessor address bus (see Table 6-11) and the associated Address Decode circuitry. By moving Jumper P503 (diagram 1) to the Diagnostic position, Data Bus Buffers U2350 and U2450 are disabled, and the Microprocessor is forced into a NOP (no operation) loop. This causes the address on the address bus to be continuously incremented for exercising the Address Decode circuitry. Troubleshooting of kernel addressing with an oscilloscope or logic analyzer is then possible.

Table 6-11
NOP Test Data

U2140 Pin #	Signal Name	1 CYCLE Time	Frequency
9	A0	3.199 μ s	312.5 kHz
10	A1	6.39 μ s	156.3 kHz
11	A2	12.79 μ s	78.15 kHz
12	A3	25.59 μ s	39.075 kHz
13	A4	51.18 μ s	19.53 kHz
14	A5	102.4 μ s	9.769 kHz
15	A6	204.7 μ s	4.88 kHz
16	A7	409.4 μ s	2.44 kHz
17	A8	818.9 μ s	1.22 kHz
18	A9	1638 μ s	610.6 Hz
19	A10	3275 μ s	305.3 Hz
20	A11	6.55 ms	152.6 Hz
22	A12	13.1 ms	76.3 Hz
23	A13	26.2 ms	38.16 Hz
24	A14	52.4 ms	19.08 Hz
25	A15	104.8 ms	9.54 Hz

CORRECTIVE MAINTENANCE

INTRODUCTION

Corrective maintenance consists of component replacement and instrument repair. This part of the manual describes special techniques and procedures required to replace components in this instrument. If it is necessary to ship your instrument to a Tektronix Service Center for repair or service, refer to the "Instrument Repackaging Instructions" in Section 2.

MAINTENANCE PRECAUTIONS

To reduce the possibility of personal injury or instrument damage, observe the following precautions.

1. Disconnect the instrument from the ac power source before removing or installing components.
2. Verify that the line-rectifier filter capacitors are discharged prior to performing any servicing.
3. Use care not to interconnect instrument grounds which may be at different potentials (cross grounding).
4. When soldering on circuit boards or small insulated wires, use only a 15-watt, pencil-type soldering iron.

OBTAINING REPLACEMENT PARTS

Most electrical and mechanical parts can be obtained through your local Tektronix Field Office or representative. However, many of the standard electronic components can usually be obtained from a local commercial source. Before purchasing or ordering a part from a source other than Tektronix, Inc., please check the "Replaceable Electrical Parts" list for the proper value, rating, tolerance, and description.

NOTE

Physical size and shape of a component may affect instrument performance, particularly at high frequen-

cies. Always use direct-replacement components, unless it is known that a substitute will not degrade instrument performance.

Special Parts

In addition to the standard electronic components, some special parts are used in the instrument. These components are manufactured or selected by Tektronix, Inc. to meet specific performance requirements, or are manufactured for Tektronix, Inc. in accordance with our specifications. The various manufacturers can be identified by referring to the "Cross Index-Manufacturer's Code Number to Manufacturer" at the beginning of the "Replaceable Electrical Parts" list. Many of the mechanical parts used in this instrument were manufactured by Tektronix, Inc. Order all special parts directly from your local Tektronix Field Office or representative.

Ordering Parts

When ordering replacement parts from Tektronix, Inc., be sure to include all of the following information:

1. Instrument type (include modification or option numbers).
2. Instrument serial number.
3. A description of the part (if electrical, include its full circuit component number).
4. Tektronix part number.

MAINTENANCE AIDS

The maintenance aids listed in Table 6-12 include items required for performing most of the maintenance procedures in this instrument. Equivalent products may be substituted for the examples given, provided their characteristics are similar.

Table 6-12
Maintenance Aids

Description	Specification	Usage	Example
1. Soldering Iron	15 to 25 W.	General soldering and unsoldering.	Antex Precision Model C.
2. Flat-bit Screwdriver	3-inch shaft, 3/32 inch bit.	Assembly and disassembly.	Xcelite Model R3323.
3. Torx Screwdriver	Tip sizes: #T9, #T10, #T15, #T20.	Assembly and disassembly.	Tektronix Part Numbers #T9 003-0965-00 #T10 003-0815-00 #T15 003-0966-00 #T20 003-0866-00
4. Nutdrivers	3/16 inch, 1/4 inch, and 5/16 inch	Assembly and disassembly.	Xcelite #6, #8 and #10.
5. Open-end Wrenches	1/4 inch, 5/16 inch, 7/16 inch.	Assembly and disassembly.	
6. Allen Wrenches	0.050 inch, 1/16 inch.	Assembly and disassembly.	
7. Long-nose Pliers		Component removal and replacement.	Diamalloy Model LN55-3.
8. Diagonal Cutters		Component removal and replacement.	Diamalloy Model M554-3.
9. Vacuum Solder Extractor	No static charge retention.	Unsoldering static sensitive devices and components on multilayer boards.	Pace Model PC-10.
10. Spray Cleaner	No-Noise	Switch and Pot cleaning.	Tektronix Part Number 006-0442-02.
11. Pin-replacement kit		Replace circuit board connector pins.	Tektronix Part Number 040-0542-00.
12. IC-Removal Tool		Removing DIP IC packages.	Augat T114-1.
13. Isopropyl Alcohol	Reagent grade.	Cleaning attenuator and front panel assemblies.	2-Isopropanol.

INTERCONNECTIONS

Interconnections in this instrument are made with pins soldered onto the circuit boards. Several types of mating connectors are used for the interconnecting pins. The following information provides the replacement procedures for the various type connectors.

End-Lead Pin Connectors

Pin connectors used to connect the wires to the interconnect pins are factory assembled. They consist of machine-inserted pin connectors mounted in plastic holders. If the connectors are faulty, the entire wire assembly should be replaced.

Multipin Connectors

When pin connectors are grouped together and mounted in a plastic holder, they are removed, reinstalled, or replaced as a unit. If any individual wire or connector in the assembly is faulty, the entire cable assembly should be replaced. Multipin connector orientation is indexed by a triangle on the cable connector and a 1 or triangle on the circuit board. Slot numbers may be molded into the connector. Be sure these index marks are aligned with each other when the multipin connector is reinstalled.

TRANSISTORS, INTEGRATED CIRCUITS, AND HYBRID CIRCUITS

Transistors, integrated circuits, and hybrid circuits should not be replaced unless they are actually defective. If removed from their sockets or unsoldered from the circuit board during routine maintenance, return them to their original board locations. Unnecessary replacement or transposing of semiconductor devices may affect the adjustment of the instrument. When a semiconductor is replaced, check the performance of any circuit that may be affected.

Any replacement component should be of the original type or a direct replacement. Bend transistor leads to fit their circuit board holes, and cut the leads to the same length as the original component. See Figure 9-2 in the "Diagrams" section for lead-configuration illustrations.

The heat-sink-mounted power supply transistors are insulated from the heat sink with a heat-transferring insulator pad. Reinstall the insulator pads and bushings when replacing these transistors. Do not use any type of heat-transferring compound on the insulator pads.

NOTE

After replacing a power transistor, check that the collector is not shorted to the heat sink before applying power to the instrument.

To remove socketed dual-in-line packaged (DIP) integrated circuits, pull slowly and evenly on both ends of the device. Avoid disengaging one end of the integrated circuit from the socket before the other, since this may damage the pins.

To remove a soldered DIP IC when it is going to be replaced, clip all the leads of the device and remove the

leads from the circuit board one at a time. If the device must be removed intact for possible reinstallation, do not heat adjacent conductors consecutively. Apply heat to pins at alternate sides and ends of the IC as solder is removed. Allow a moment for the circuit board to cool before proceeding to the next pin.

Hybrid circuits and heatsinks are removed as a unit by removing the mounting nuts at the four corners of the heatsink/housing. A firm downward pressure at the center of the heatsink will aid in installation/removal of the nuts. The hybrid circuit substrate is bonded to the heatsink/housing casting. Attempting to separate the hybrid device from its heatsink will damage the device.

SOLDERING TECHNIQUES

The reliability and accuracy of this instrument can be maintained only if proper soldering techniques are used to remove or replace parts. General soldering techniques, which apply to maintenance of any precision electronic equipment, should be used when working on this instrument.

WARNING

To avoid an electric-shock hazard, observe the following precautions before attempting any soldering: turn the instrument off, disconnect it from the ac power source, and verify that the line-rectifier filter capacitors have discharged (see label on the primary power shield). If, due to a component failure, the capacitors are not discharging, it may be necessary to discharge them. Use a 1 k Ω 5-watt resistor and discharge the capacitors from point to point through the access holes in the primary power shield.

Use rosin-core wire solder containing 63% tin and 37% lead. Contact your local Tektronix Field Office or representative to obtain the names of approved solder types.

When soldering on circuits boards or small insulated wires, use only a 15-watt, pencil-type soldering iron. A higher wattage soldering iron may cause etched circuit conductors to separate from the board base material and melt the insulation on small wires. Always keep the soldering-iron tip properly tinned to ensure best heat transfer from the iron tip to the solder joint. Apply only

enough solder to make a firm joint. After soldering, clean the area around the solder connection with an approved flux-removing solvent (such as isopropyl alcohol) and allow it to air dry.

Circuit boards in this instrument may have as many as four conductive layers. Conductive paths between the top and bottom board layers may connect to one or more inner layers. If any inner-layer conductive path becomes broken due to poor soldering practices, the board becomes unusable and must be replaced. Damage of this nature can void the instrument warranty.

CAUTION

Only an experienced maintenance person proficient in the use of vacuum-type desoldering equipment should attempt repair of any circuit board in this instrument.

Desoldering parts from multilayer circuit boards is especially critical. Many integrated circuits are static sensitive and may be damaged by solder extractors that generate static charges. Perform work involving static-sensitive devices only at a static-free work station while wearing a grounded antistatic wrist strap. Use only an antistatic vacuum-type solder extractor approved by a Tektronix Service Center.

CAUTION

Attempts to unsolder, remove, and resolder leads from the component side of a circuit board may cause damage to the reverse side of the circuit board.

The following techniques should be used to replace a component on a circuit board:

1. Touch the vacuum desoldering tool to the lead at the solder connection. Never place the iron directly on the board; doing so may damage the board.

NOTE

Some components are difficult to remove from the circuit board due to a bend placed in the component leads during machine insertion. To make removal of machine-inserted components easier, straighten the component leads on the reverse side of the circuit board.

2. When removing a multipin component, especially an IC, do not heat adjacent pins consecutively. Apply heat to the pins at alternate sides and ends of the IC as solder is removed. Allow a moment for the circuit board to cool before proceeding to the next pin.

CAUTION

Excessive heat can cause the etched circuit conductors to separate from the circuit board. Never allow the solder extractor tip to remain at one place on the board for more than three seconds. Solder wick, spring-actuated or squeeze-bulb solder suckers, and heat blocks (for desoldering multipin components) must not be used. Damage caused by poor soldering techniques can void the instrument warranty.

3. Bend the leads of the replacement component to fit the holes in the circuit board. If the component is replaced while the board is installed in the instrument, cut the leads so they protrude only a small amount through the reverse side of the circuit board. Excess lead length may cause shorting to other conductive parts.

4. Insert the leads into the holes of the board so that the replacement component is positioned the same as the original component. Most components should be firmly seated against the circuit board.

5. Touch the soldering iron to the connection and apply enough solder to make a firm solder joint. Do not move the component while the solder hardens.

6. Cut off any excess lead protruding through the circuit board (if not clipped to the correct length in step 3).

7. Clean the area around the solder connection with an approved flux-removing solvent. Be careful not to remove any of the printed information from the circuit board.

8. When soldering to the ceramic CRT-termination network, a slightly larger soldering iron can be used. It is recommended that a solder containing about 3% silver be used when soldering to the ceramic material to avoid destroying the bond. The bond can be broken by repeated use of ordinary tin-lead solder or by the application of too much heat; however, occasional use of ordinary solder will not break the bond, provided excessive heat is not applied when making the connection.

REMOVAL AND REPLACEMENT INSTRUCTIONS

WARNING

To avoid electric shock, disconnect the instrument from the ac power source before removing or replacing any component or assembly.

WARNING

Removal of the cabinet and other external panels leaves the CRT exposed for possible damage. All procedures in these instructions require careful attention to avoid damage to the CRT which could cause it to implode. An implosion creates high speed glass fragments. Wear protective clothing and use safety shields as required. See "WARNING" in "CRT REMOVAL".

The exploded view drawing in the "Replaceable Mechanical Parts" list at the rear of this manual may be helpful during the removal and reinstallation of individual components or subassemblies. Circuit board and component locations are illustrated in the "Diagrams" section of this manual.

Cabinet Removal

Removal of the instrument wrap-around cabinet is accomplished by the following steps:

1. Unplug the power cord from the ac power source.
2. Unplug the power cord from the rear-panel connector.
3. Install the front cover, place the cabinet carrying handle against the bottom of the cabinet, and set the instrument face down on a flat surface.
4. Unwrap the power cord and remove it.
5. Remove the four screws in the rear feet.

6. Remove the two screws from the top-center and bottom-center of the rear cover.

7. Lift the rear cover and power cord away from the instrument, leaving the rear feet attached.

WARNING

Dangerous potentials exist at several points throughout this instrument. If it is operated with the cabinet removed, do not touch exposed connections or components. Some transistors may have elevated case voltages. Disconnect the ac power source from the instrument and verify that the line-rectifier filter capacitors have discharged before cleaning the instrument or replacing parts (see label on the primary power shield).

8. Slide the cabinet off the instrument.

To reinstall the wrap-around cabinet, perform the reverse of the preceding instructions. Ensure that the cabinet fits properly into the EMI gasket grooves in the front frame and rear panel.

WARNING

The line-rectifier filter capacitors normally retain a charge for a short period (approximately 15 to 20 seconds) after the instrument is turned off and can remain charged for a longer period if a bleeder-resistor or power-supply problem occurs. Before beginning any cleaning or work on the internal circuitry of the oscilloscope, disconnect the ac power source from the instrument and verify that the capacitors have discharged to 24 V or less. Measurement is made at the three points indicated on the plastic primary input shield at the rear of the instrument (after the Top-Cover Plate is removed). If the capacitors retain charges of greater than 24 V for more than 20 seconds, discharge them using a 1 k Ω , 5-watt resistor connected point-to-point across the capacitors through the access holes. Ensure that the capacitors are discharged before starting to troubleshoot.

Vertical Bracket (Top-Cover Plate) Removal

To remove the Vertical Bracket from instruments that do not have the DMM option installed, perform the following steps:

1. Remove the instrument Cabinet as described in that procedure.
2. Set the instrument, bottom down, on a flat surface.
3. Remove two top securing screws at the front edge of the Vertical Bracket.
4. Remove the two screws in the right-center of the Vertical Bracket.
5. Remove the top securing screw at the left-rear of the Vertical Bracket.
6. Remove the securing screw from the chassis rear plate.
7. Remove the securing screw from the left side of the chassis.
8. Lift the Vertical Bracket up and away from the instrument.

To reinstall the Vertical Bracket, perform the reverse of the preceding instructions. Be certain to align the circuit board at the right rear with the two black grommets installed in the Vertical Bracket. Align the two black plastic pins on the power supply assembly with their mating holes before installing and tightening screws.

A5—Control Board Removal

Removal of the Control Board is accomplished by the following steps:

1. Remove the instrument wrap-around cabinet as described in that procedure.

2. Place the instrument on its left side on a flat surface.

3. Disconnect the two ribbon-cable and one flex-circuit connectors (P251, P651, and P652) from the Control board (see Figure 6-2).

4. Disconnect the two ribbon-cable connectors (P511 and P512) from the Main Board.

5. Remove the five mounting screws securing the Control board to the chassis, one at each corner of the board and one at the center.

6. Lift the Control board away from the chassis.

To reinstall the Control board, perform the reverse of the preceding instructions.

FAN REMOVAL. To remove the Fan from instruments that do not have the DMM option installed:

1. Desolder the wires from the feed-through capacitor (C10) and ground lug, noting color code for reassembly.

2. Remove the Fan retainer screw, located above the Fan.

To reinstall the Fan, perform the reverse of the above instructions. Align the holes in the Fan flange with the pins on the rear plate before tightening the screw.

A2, A3, and A12—Power Supply Assembly Removal

Removal of the Power Supply assembly from instruments that do not contain options is accomplished by the following steps:

1. Remove the instrument Cabinet as described in that procedure.

2. Remove the Vertical Bracket as described in that procedure.

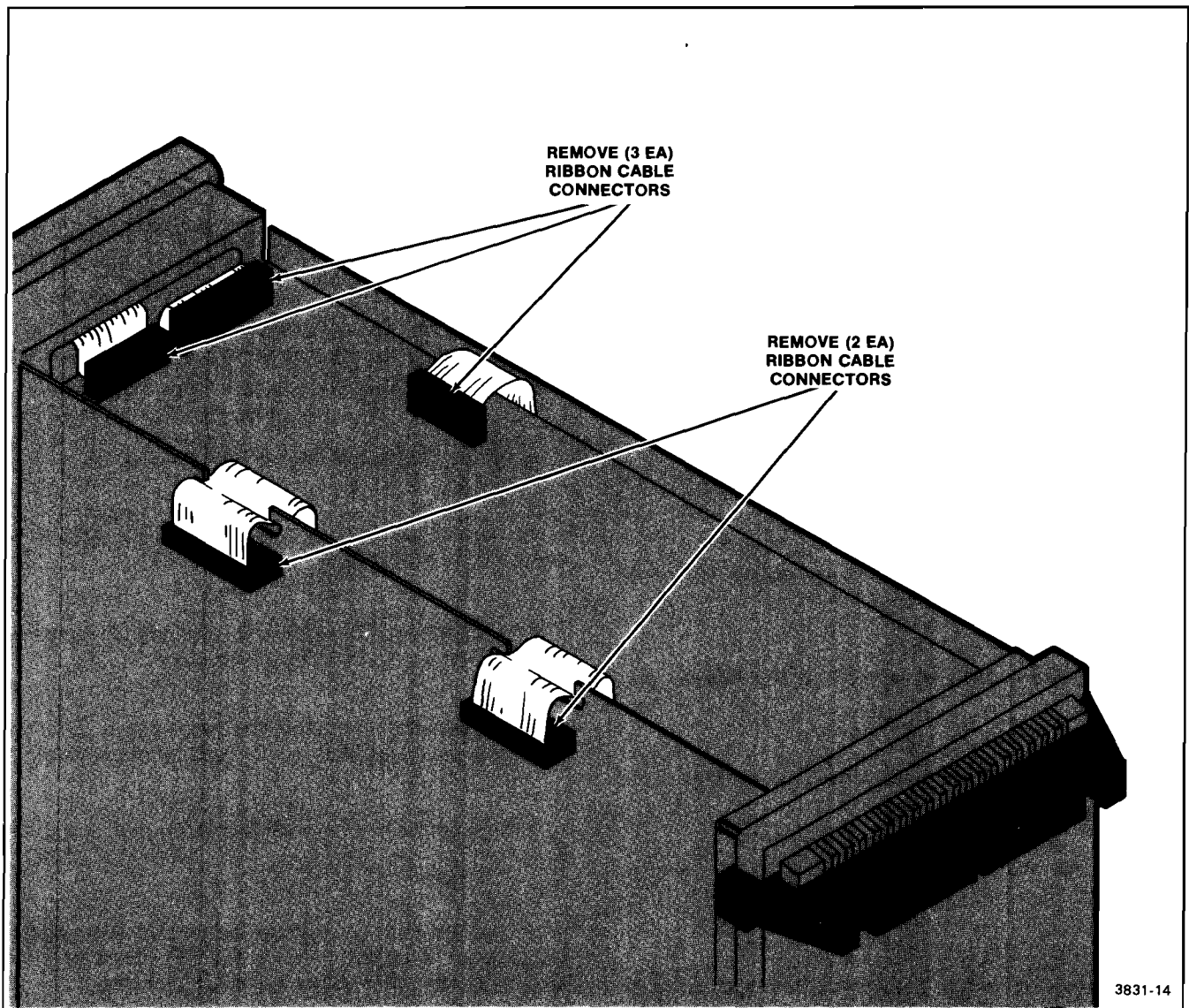

Figure 6-2. Ribbon cable removal.

3. Remove the Fan as described in that procedure.
4. Desolder the Fan power cable connecting the power supply to the feed-through capacitor (C10) on the inside of the rear plate.
5. Remove the two screws in the rear plate holding the black plastic primary circuit shield (located inside the chassis) and remove the shield.
6. Remove the two screws holding the rear of the Power Supply assembly to the rear plate.
7. Remove the three screws securing the power-transistor heatsink to the chassis.
8. Disconnect the power supply ribbon-cable connector (P251) from the Control board and feed the cable through the notch in the Control board and slot in the chassis.

9. Disconnect the two cables (P121 and P122) connecting the Main board to the Power Supply from the side of the Power Supply assembly.

10. Disconnect the four primary power connectors (P204, P205, P206, and P207) at the rear of the Power Supply assembly. Note their orientation for reinstallation.

11. If the Probe Power option is installed, disconnect the Probe Power connectors (P201 and P202) from the Power Supply assembly.

12. Lift the Power Supply assembly from the instrument.

To reinstall the Power Supply assembly, perform the reverse of the preceding instructions.

The following procedures describe the further disassembly of the Power Supply assembly circuit boards once the assembly is removed from the instrument.

INVERTER BOARD AND REGULATOR BOARD SEPARATION. To separate the Inverter and Regulator boards, perform the following steps:

1. Remove the rear-corner securing screw from the Regulator board and the two screws at the front edge of this board.

2. Unplug the four pin disconnect terminals (J231, J232, J233, and J234) while disabling the locking leg on the connector retainer.

3. Separate the two circuit boards by removing the four black plastic spacers from the top and bottom edges of the assembly.

To rejoin the Inverter and Regulator boards, perform the reverse of the preceding steps.

A9—High-Voltage Board Removal

Removal of the High-Voltage board is accomplished by the following steps:

1. Remove the instrument Cabinet as described in that procedure.

2. Remove the Vertical Bracket as described in that procedure.

WARNING

The CRT anode lead may retain a high-voltage charge after the instrument is turned off. To avoid electrical shock, ground the CRT anode lead to the chassis after disconnecting the plug. Reconnect and disconnect the anode-lead plug several times, grounding the anode lead to chassis ground each time it is disconnected to fully dissipate the charge.

3. Unplug the CRT anode lead and discharge it to chassis ground.

4. Remove the high-voltage lead from the retainer cap.

5. Unplug the two leads connecting the CRT to the ceramic CRT terminator. Use long-nose pliers to pull the connectors straight away from the CRT neck pins. Avoid putting pressure on the metal-to-glass seal at the base of the pins.

6. Disconnect the single conductor connector from the ceramic CRT terminator.

7. Remove the two nuts retaining the ceramic CRT terminator to the chassis and remove the terminator.

8. Remove the nut retaining the high-voltage lead clamp to the chassis and remove the clamp.

9. Remove three screws on the rear CRT cover. Remove the cover.

10. Remove the five screws securing the High-Voltage Shield and remove the shield. If optional assembly cables are mounted in the shield's groove, it will be necessary to loosen these cables from the option board enough to slip the cover out underneath them.

11. Remove the high-voltage lead from the u-shaped grommet in the rear plate.

Maintenance—2445A/2455A Service

12. Unplug the CRT socket by gently prying evenly on both sides of the socket until the socket can be disengaged from the CRT pins. Do not apply side pressure on the socket.

13. Disconnect the connectors (P901, P902, P903, and P904) from the High-Voltage board. Note connector orientation for reinstallation.

14. Remove the four spacer posts securing the High-Voltage Board to the chassis.

15. Carefully tilt the top of the High Voltage board out far enough to clear the chassis side flange while pulling the board up gently to disengage the High-Voltage board pin connectors from the Main board.

16. Lift the board from the chassis while carefully feeding the CRT socket, cabling, and high-voltage lead through the rear plate slot.

To reinstall the High-Voltage Board, perform the reverse of the preceding instructions.

A4—Readout Board Removal

Removal of the Readout Board is accomplished by the following steps:

1. Remove the instrument Cabinet as described in that procedure.

2. Remove the Vertical bracket as described in that procedure.

3. Place the instrument, left side down, on a flat surface.

4. Disconnect the Readout board ribbon-cable connector (P411) from the Main board.

5. With the instrument still on its side, pull the Readout board out of its plastic board mounts. Remove it from the instrument while guiding the ribbon cable and connector through the slots in the Main board and chassis.

To reinstall the Readout board, perform the reverse of the preceding steps.

A6—Front-Panel Circuit Board Assembly Removal

Removal of the Front-Panel circuit board assembly is accomplished by the following steps:

1. Remove the instrument Cabinet as described in that procedure.

2. Set the instrument back into its rear cover with the CRT facing up. Using a small-bladed screwdriver, gently pry up on the top cover trim strip to release it from the top edge of the front decorative trim ring.

3. Remove the four screws from the top edge of the front decorative trim ring.

4. Remove the four screws and the two plastic feet from the bottom edge of the front decorative trim ring.

5. Using firm outward pressure, pull the knobs from the four controls directly below the CRT (INTENSITY, FOCUS, READOUT INTENSITY, and SCALE ILLUM).

6. Slide off the front decorative trim ring. The clear implosion shield is retained by the trim ring. Use care to avoid dislodging the shield accidentally from its recess in the CRT frame.

7. Disconnect the ribbon-cable connector (P652) and the flex-circuit connector (P651) from the front of the Control Board. Feed the flex-circuit connector through the slot carefully while sliding the front panel gently outward.

8. Pull out the Front-Panel Circuit Board Assembly.

The following steps describe the further disassembly of the Front-Panel Assembly once it is removed from the instrument.

ASSEMBLY SEPARATION. Separation of the pot holder module from the Front-Panel Board is accomplished by the following steps:

1. Using a 1/16-inch Allen wrench, loosen the set screws in the CH 1 VOLTS/DIV VAR, CH 2 VOLTS/DIV VAR, and A and B SEC/DIV VAR knobs and remove these three knobs from their control shafts.

2. Using a 1/16-inch Allen wrench, loosen the six set screws in the CH 1 and CH 2 VOLTS/DIV knobs, and the SEC/DIV knob. Remove these three knobs from their control shafts.

3. Using firm outward pressure, pull off the remaining knobs. Note the locations of the knobs with indicator bars for reference during reinstallation.

4. On the rear of the assembly, remove the four screws securing the black variable resistor holder assembly.

5. Separate and slide out the above assembly with attached variable-control shafts. Avoid stressing the shafts to the side while sliding the assembly out.

FRONT-PANEL REMOVAL. Use the following procedure to further disassemble the Front-Panel circuit board assembly.

1. Separate the Front-Panel and variable resistor holder assembly as described above (if not already done).

2. Lift up the circuit board carefully to avoid dislodging any of the square push buttons from their switches.

3. Lift off the black plastic switch guide and mounting ring.

To reassemble and reinstall the Front-Panel assembly, perform the reverse of the preceding instructions. When reinstalling the circuit board, align all push buttons and LEDs with the black plastic switch guides before installing and tightening the screws.

A10 and A11—Channel 1 and Channel 2 Attenuator Assembly Removal

Removal of either the Channel 1 or Channel 2 Attenuator assembly is accomplished by the following steps:

1. Remove the instrument Cabinet as described in that procedure.

2. Remove the Front-Panel assembly as described in that procedure.

3. Remove the two screws holding the Attenuator support bar and remove the bar.

4. For each attenuator, remove the two screws holding the Attenuator to the front subpanel and the two screws holding it to the Main board (through access holes in the front panel compartment of the chassis).

5. Disconnect the associated multipin connector (either P10 for Channel 1 or P11 for Channel 2) from the Main board.

6. Remove the two screws holding the preamplifier shield and ground clip and remove them.

7. Desolder the two Attenuator output leads and the compensation capacitor lead.

8. Unplug the Attenuator by gently pulling the assembly straight up and away from the Main Board.

To reinstall a removed Attenuator assembly, perform the reverse of the preceding steps.

A1—Main Board Removal

Removal of the Main Board is accomplished by the following steps:

1. Remove the instrument Cabinet as described in that procedure.

2. Remove the Vertical Bracket as described in that procedure.

3. Remove the Front-Panel circuit board assembly as described in that procedure.

Maintenance—2445A/2455A Service

4. Disconnect the two power-supply multipin connectors (P121 and P122) from the side of the Power Supply assembly.

5. Disconnect the three ribbon-cable connectors (P411, P511, and P512) from the bottom of the Main board.

NOTE

See "Warning" under CRT Removal before proceeding.

6. Disconnect the vertical and horizontal deflection leads from the neck pins of the CRT. Access is via holes in the Main board. Use long-nose pliers to disconnect the pins by gently pulling straight up on the connectors. Avoid putting side pressure on the metal-to-glass seal of the CRT neck pins.

7. Desolder the rear-panel BNC connector leads from the BNCs. Unplug the CH 2 OUT cable (P105) from the Main board, and remove its cable retaining clamp.

8. Disconnect the flex-circuit connector (P120) for the CRT controls from the Main board.

9. Disconnect the two-conductor connector (P181) for the Scale Illumination board near the ASTIG and the SCALE ILLUM controls.

10. Remove the STEP/AUTO jack (J12) retaining nut from the rear plate after desoldering its wire from the Main board using correct vacuum desoldering techniques. Remove the jack.

11. Turn the long extension shaft (see Figure 6-3) CCW and unsnap it from the pivot bracket at the rear middle of the Main board, sliding it out of the bracket sideways.



Do not pull on the power switch push button or it will be damaged.

12. Remove the power switch push button mounting screw (item A) shown in Figure 6-3. Separate the long extension shaft from the short extension shaft at point B by inserting a small screwdriver tip in the slot while pulling out on the bracket at point C. Remove the screw (item D) and slide the long extension shaft out the rear of the front frame.

13. Remove the two screws holding the Attenuator support bar and remove the bar.

14. Remove the six screws holding the Attenuator assemblies and the CH 3 and CH 4 input connectors to the front subpanel.

15. Remove the Main board mounting screws (ten screws total) securing the Main board to the chassis.

16. Lift the rear of the Main board away from the chassis to unplug J191 and separate the Main board from the High Voltage board. When the plug pins are completely disengaged and the rear of the board clears the rear frame, slide the Main board rearward out of the front subpanel. Lift the Main board (with attached Delay Line) clear of the instrument while working the power supply cables through the slot in the chassis.

To reinstall the Main board, perform the reverse of the preceding instructions.

A8—Scale Illumination Circuit Board Removal

NOTE

See "Warning" under CRT removal instructions before proceeding.

Removal of the Scale-Illumination Circuit Board is accomplished by the following steps:

1. Remove the instrument Cabinet as described in that procedure.

2. Remove the front decorative trim ring as described in the A6—Front Panel board removal procedure.

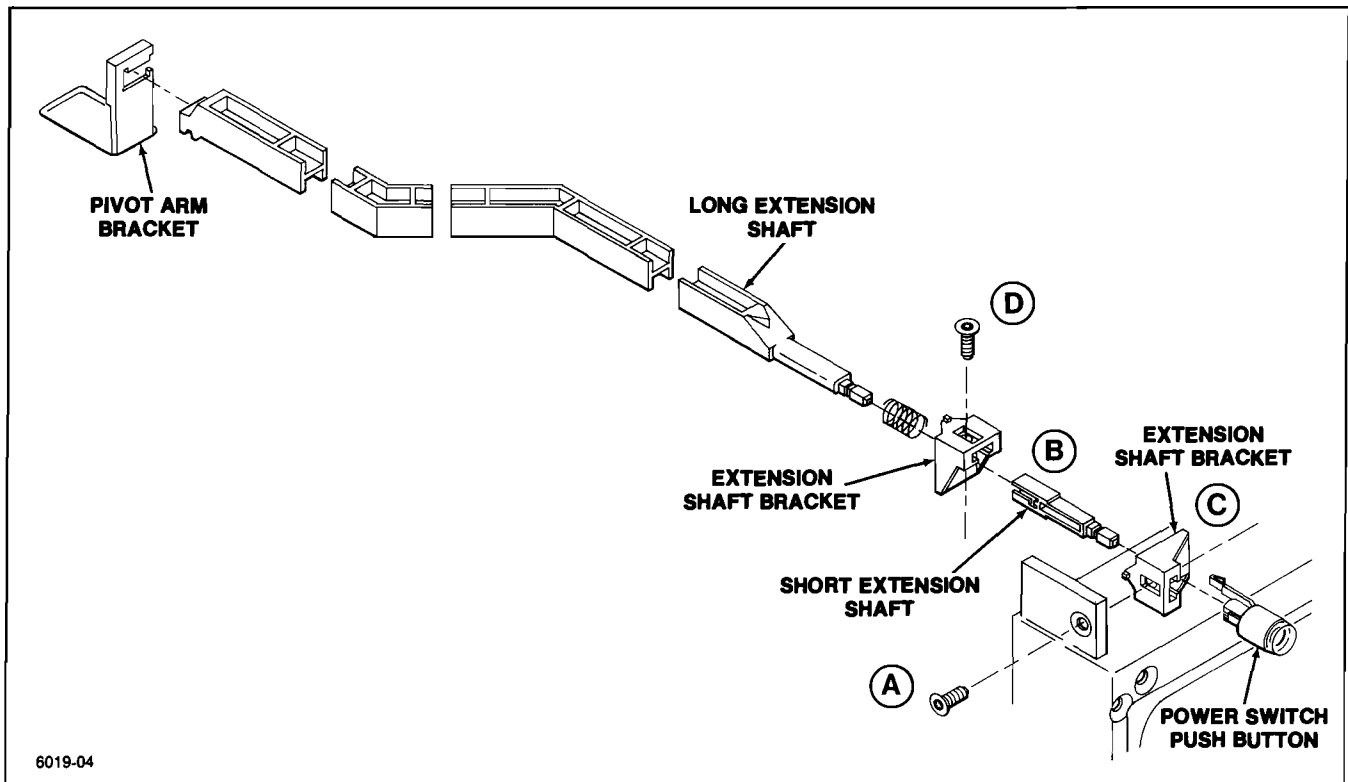

Figure 6-3. Power Switch Push Button Disassembly.

3. Remove the eight screws in the CRT frame. Remove frame and black plastic gasket. Note the difference in length of the screws for reinstallation.

4. Remove the clear plastic light reflector from the Scale-Illumination circuit board and the black plastic mounting spacer.

5. Disconnect the scale-illumination multipin connector (P181) from the Main board.

6. Remove the Scale-Illumination circuit board by lifting it away from the front subpanel while working the wires and connector through the slot in the subpanel.

To reinstall the Scale-Illumination circuit board, perform the reverse of the preceding instructions.

CRT Removal

WARNING

Use care when handling a CRT. Breakage of the CRT may cause high-speed scattering of glass fragments (implosion). Protective clothing and safety glasses (preferably a full-face shield) should be worn. Avoid striking the CRT on any object which may cause it to crack or implode. When storing a CRT, place it in a protective carton or set it face down on a smooth surface in a protected location. When stored face down, it should be placed on a soft, nonabrasive surface to prevent the CRT face plate from being scratched.

Maintenance—2445A/2455A Service

1. Remove the instrument Cabinet as described in that procedure.

2. Remove the Vertical Bracket as described in that procedure.

3. Remove three screws on the rear CRT cover. Remove the cover.

4. Unplug the CRT socket by gently prying the socket evenly on both sides until the pins can be disengaged. Do not apply side pressure on the socket.

WARNING

The CRT anode lead and the output terminal of the High-Voltage Multiplier can retain a high-voltage charge after the instrument is turned off. To avoid electrical shock, ground both the CRT anode lead and the high-voltage lead to the main instrument chassis. Repeat the grounding process several times to fully dissipate the charge.

5. Disconnect the CRT anode lead connector and discharge it to chassis ground.

6. Using long-nosed pliers, disconnect the horizontal and vertical deflection leads from the bottom of the CRT. Pull straight out on these connectors to prevent strain on the metal-to-glass seal. (Access to the connectors is through holes in the Main board).

7. Using long-nosed pliers, disconnect the vertical termination leads from the top of the CRT. Also disconnect the CRT shield ground lead from the top of the CRT.

8. Remove the five screws securing the High-Voltage Shield and remove the shield. If optional assembly cables are mounted in the shield's groove, it will be necessary to loosen these cables from the option board enough to slip the cover out underneath them.

9. Disconnect the connector (P903) from the front of the High-Voltage board. Note connector orientation for reinstallation.

10. Remove the front decorative trim ring as described in the A6—Front-Panel circuit board assembly removal instructions.

11. Remove the eight retaining screws from the CRT-mounting bezel at the front of the CRT. Note the difference in length of the screws for reinstallation. Push in on the four longer (outer) screws to disengage the CRT retainers.

12. Remove the CRT frame and black plastic gasket from the front of the instrument, working the frame gently from side to side to free it from the CRT (if required).

13. Slide the CRT out of the instrument while feeding the CRT leads through their respective holes in the CRT shield and front subpanel.

NOTE

Once the CRT is removed, it should be stored in such a manner as to protect it from impact. If stored face down, it should be placed on a soft, non-abrasive surface to prevent the CRT face plate from being scratched. To reinstall the CRT, perform the reverse of the preceding instructions. Be certain the two pins on the lower edge of the CRT frame align with the hole and slot in the front subpanel of the chassis. Tighten the shorter screws to 10 in-lb of torque before tightening any of the longer screws. Then tighten the longer screws in sequence:

2 1

4 3

Screw number one aligns the CRT. On the third time through the sequence, tighten each screw to 10 in-lb of torque.

OPTIONS

INTRODUCTION

This section contains a general description of instrument options available at the time of publication of this manual. Additional information about instrument options and option availability can be obtained either by consulting the current Tektronix Product Catalog or by contacting your local Tektronix Field Office or representative.

POWER CORD OPTIONS

Instruments are shipped with the detachable power-cord configuration ordered by the customer. Descriptive information about the international power-cord options is provided in Section 2, "Preparation for Use." The following list identifies the Tektronix part numbers for the optional power cords and associated fuses.

Option A1 (Universal Euro)

Power cord (2.5 m)	161-0104-06
Fuse (1.6 A, 250 V, 5 x 20 mm, Quick-acting)	159-0098-00

Option A2 (UK)

Power cord (2.5 m)	161-0104-07
Fuse (1.6 A, 250 V, 5 x 20 mm, Quick-acting)	159-0098-00

Option A3 (Australian)

Power Cord (2.5 m)	161-0104-05
Fuse (1.6 A, 250 V, 5 x 20 mm, Quick-acting)	159-0098-00

Option A4 (North American)

Power Cord (2.5 m)	161-0104-08
Fuse (2 A, 250 V, AGC/3AG, Fast-blow)	159-0021-00

Option A5 (Switzerland)

Power Cord (2.5 m)	161-0167-00
Fuse (1.6 A, 250 V, 5 x 20 mm, Quick-acting)	159-0098-00

OPTION 1R

When the oscilloscope is ordered with Option 1R, it is shipped in a configuration that permits easy installation into a 19-inch-wide electronic-equipment rack.

An optional rear-support kit is also available for use when rackmounting the instrument. Using this optional rear-support kit enables the rackmounted instrument to meet appropriate electrical and environmental specifications.

Connector-mounting holes are provided in the front panel of the rackmounted instrument. These enable convenient accessing of the four bnc connectors (CH 2 SIGNAL OUT, A GATE OUT, B GATE OUT, and EXT Z AXIS IN) and the two PROBE POWER connectors located on the rear panel. Additional cabling and connectors required to implement any front-panel access to the rear-panel connectors are supplied by the user; however, these items can be separately ordered from Tektronix.

Complete rackmounting instructions are provided in a separate document shipped with Option 1R. These instructions also contain appropriate procedures to convert a standard instrument into the Option 1R configuration by using the rackmounting conversion kit.

OPTION 01

Option 01 (DMM) adds a 4-1/2 digit, fully autoranging digital multimeter which measures dc and ac voltage and current, resistance, dBV, dBm, continuity, and temperature. Option 1B is the same as Option 01 except that the temperature probe is not included. Measurement results and DMM messages are displayed on the top line of the oscilloscope CRT readout.

OPTION 05

Option 05 (TV) simplifies triggering and viewing of television signals. The option adds TV (back-porch) clamp circuitry to the Channel 2 input and TV trigger coupling modes, allowing selection of either horizontal or vertical sync pulses to obtain horizontal-line-sync or field-sync pulse triggering. This option permits triggering on a specific line number within a TV field and provides sync polarity switching for either sync-negative or sync-positive composite video signals.

OPTIONS 06 AND 09

Options 06 (Counter/Timer/Trigger) and 09 (Counter/Timer/Trigger with Word Recognizer) allow precision time-interval measurement, event and frequency

counting, delay-by-events triggering, and logic triggering. The 17-bit Word Recognizer probe of Option 09 extends the capabilities of these functions.

OPTION 10

Option 10 allows the instrument to be remotely controlled and queried using a standard interface system. The interface implemented conforms to the specifications contained in *IEEE Standard Digital Interface for Programmable Instrumentation (ANSI/IEEE Std 488-1978)*, commonly referred to as the General Purpose Interface Bus (GPIB). It also complies with a Tektronix Standard relating to GPIB Codes, Formats, Conventions and Features.

REPLACEABLE ELECTRICAL PARTS

PARTS ORDERING INFORMATION

Replacement parts are available from or through your local Tektronix, Inc. Field Office or representative.

Changes to Tektronix instruments are sometimes made to accommodate improved components as they become available, and to give you the benefit of the latest circuit improvements developed in our engineering department. It is therefore important, when ordering parts, to include the following information in your order: Part number, instrument type or number, serial number, and modification number if applicable.

If a part you have ordered has been replaced with a new or improved part, your local Tektronix, Inc. Field Office or representative will contact you concerning any change in part number.

Change information, if any, is located at the rear of this manual.

Only the circuit number will appear on the diagrams and circuit board illustrations. Each diagram and circuit board illustration is clearly marked with the assembly number. Assembly numbers are also marked on the mechanical exploded views located in the Mechanical Parts List. The component number is obtained by adding the assembly number prefix to the circuit number.

The Electrical Parts List is divided and arranged by assemblies in numerical sequence (e.g., assembly A1 with its subassemblies and parts, precedes assembly A2 with its subassemblies and parts).

Chassis-mounted parts have no assembly number prefix and are located at the end of the Electrical Parts List.

LIST OF ASSEMBLIES

A list of assemblies can be found at the beginning of the Electrical Parts List. The assemblies are listed in numerical order. When the complete component number of a part is known, this list will identify the assembly in which the part is located.

CROSS INDEX-MFR. CODE NUMBER TO MANUFACTURER

The Mfr. Code Number to Manufacturer index for the Electrical Parts List is located immediately after this page. The Cross Index provides codes, names and addresses of manufacturers of components listed in the Electrical Parts List.

ABBREVIATIONS

Abbreviations conform to American National Standard Y1.1.

COMPONENT NUMBER (column one of the Electrical Parts List)

A numbering method has been used to identify assemblies, subassemblies and parts. Examples of this numbering method and typical expansions are illustrated by the following:

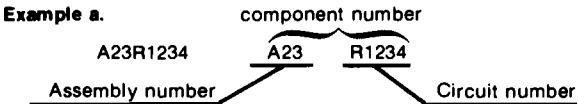

Read: Resistor 1234 of Assembly 23

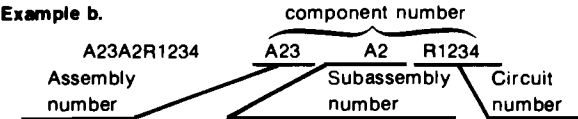

Read: Resistor 1234 of Subassembly 2 of Assembly 23

TEKTRONIX PART NO. (column two of the Electrical Parts List)

Indicates part number to be used when ordering replacement part from Tektronix.

SERIAL/MODEL NO. (columns three and four of the Electrical Parts List)

Column three (3) indicates the serial number at which the part was first used. Column four (4) indicates the serial number at which the part was removed. No serial number entered indicates part is good for all serial numbers.

NAME & DESCRIPTION (column five of the Electrical Parts List)

In the Parts List, an Item Name is separated from the description by a colon (:). Because of space limitations, an Item Name may sometimes appear as incomplete. For further Item Name identification, the U.S. Federal Cataloging Handbook H6-1 can be utilized where possible.

MFR. CODE (column six of the Electrical Parts List)

Indicates the code number of the actual manufacturer of the part. (Code to name and address cross reference can be found immediately after this page.)

MFR. PART NUMBER (column seven of the Electrical Parts List)

Indicates actual manufacturers part number.

CROSS INDEX - MFR. CODE NUMBER TO MANUFACTURER

Mfr. Code	Manufacturer	Address	City, State, Zip Code
00213	NYTRONICS COMPONENTS GROUP INC SUBSTIARY OF NYTRONICS INC	ORANGE ST	DARLINGTON SC 29532
00779	AMP INC	P O BOX 3608	HARRISBURG PA 17105
01121	ALLEN-BRAOLEY CO	1201 SOUTH 2ND ST	MILWAUKEE WI 53204
01295	TEXAS INSTRUMENTS INC SEMICONDUCTOR GROUP	13500 N CENTRAL EXPRESSWAY P O BOX 225012 W/S 49	DALLAS TX 75265
02113	COILCRAFT INC	1102 SILVER LAKE RD	CARY IL 60013
02114	AMPEREX ELECTRONIC CORP FERROXCUBE DIV	5083 KINGS HWY	SAUGERTIES NY 12477
02735	RCA CORP SOLID STATE DIVISION	ROUTE 202	SOMERVILLE NJ 08876
03508	GENERAL ELECTRIC CO SEMI-CONDUCTOR PRODUCTS DEPT	M GENESEE ST	AUBURN NY 13021
04222	AVX CERAMICS DIV OF AVX CORP	19TH AVE SOUTH P O BOX 867	MYRTLE BEACH SC 29577
04713	MOTOROLA INC SEMICONDUCTOR GROUP	5005 E MCDOWELL RD	PHOENIX AZ 85008
05292	ITT COMPONENTS DIV		CLIFTON NJ
05397	UNION CARBIDE CORP MATERIALS SYSTEMS DIV	11901 MADISON AVE	CLEVELAND OH 44101
05828	GENERAL INSTRUMENT CORP GOVERNMENT SYSTEMS DIV	600 W JOHN ST	HICKSVILLE NY 11802
06665	PRECISION MONOLITHICS INC SUB OF BOURNS INC	1500 SPACE PARK OR	SANTA CLARA CA 95050
07263	FAIRCHILD CAMERA AND INSTRUMENT CORP SEMICONDUCTOR DIV	464 ELLIS ST	MOUNTAIN VIEW CA 94042
07716	TRM INC TRM ELECTRONICS COMPONENTS	2850 MT PLEASANT AVE	BURLINGTON IA 52601
09019	TRM IRC FIXED RESISTORS/BURLINGTON GENERAL ELECTRIC CO SEMI-CONDUCTOR PRODUCTS DEPT OPERATIONAL PLANNING AND CUSTOMER ENGINEERING	ELECTRONICS PARK	SYRACUSE NY 13201
09353	C AND K COMPONENTS INC	15 RIVERDALE AVE	NENTON MA 02158
09922	BURNOY CORP	RICHARDS AVE	NORMALK CT 06852
11236	CTS OF BERNE INC	406 PARR ROAD	BERNE IN 46711
12954	MICROSEMI CORP	8700 E THOMAS RD P O BOX 1390	SCOTTSDALE AZ 85252
12969	UNITRODE CORP	580 PLEASANT ST	WATERTOWN MA 02172
14301	ANDERSON ELECTRONICS INC	310 PENN ST	HOLLIDAYSBURG PA 16648
14433	ITT SEMICONDUCTORS DIV		WEST PALM BEACH FL
14552	MICRO/SEMICONDUCTOR CORP	2830 S FAIRVIEW ST	SANTA ANA CA 92704
14752	ELECTRO CUBE INC	1710 S DEL MAR AVE	SAN GABRIEL CA 91776
15454	AMETEK INC RODAN DIV	2905 BLUE STAR ST	ANAHEIM CA 92806
18324	SIGNETICS CORP	811 E ARQUES	SUNNYVALE CA 94086
19701	MEPCO/ELECTRA INC A NORTH AMERICAN PHILIPS CO	P O BOX 760	MINERAL WELLS TX 76067
20462	PREM ENTERPRISES, INC.	3519 N. CHAPEL HILL	MCHENRY, IL 60050
20932	KYOCERA INC	11620 SORRENTO VALLEY RD	SAN DIEGO CA 92121
22526	DU PONT E I DE NEMOURS AND CO INC DU PONT CONNECTOR SYSTEMS	30 HUNTER LANE	CAMP HILL PA 17011
24546	CORNING GLASS WORKS	550 HIGH ST	BRADFORD PA 16701
25088	SIEMENS CORP	186 WOOD AVE S	ISELIN NJ 08830
27264	MOLEX INC CORPORATE HQ	2222 WELINGTON COURT	LISLE IL 60532
31471	AMERICAN MICRO SYSTEMS INC	3800 HOMESTEAD RD	SANTA CLARA CA 95051
31918	ITT SCHADOM INC	8081 MALLACE RD	EDEN PRAIRIE MN 55343
32159	WEST-CAP ARIZONA	2201 E ELVIRA ROAD	TUCSON AZ 85706
32997	BOURNS INC TRIMPOT DIV	1200 COLUMBIA AVE	RIVERSIDE CA 92507
34335	ADVANCED MICRO DEVICES	901 THOMPSON PL	SUNNYVALE CA 94086
34479	RENCO CORP.	26 COROMAR DRIVE	GOLETA, CA 93117
50434	HEWLETT-PACKARD CO OPTOELECTRONICS DIV	640 PAGE MILL RD	PALO ALTO CA 94304
51406	MURATA ERIE NORTH AMERICA INC GEORGIA OPERATIONS	1148 FRANKLIN RD SE	MARIETTA GA 30067

CROSS INDEX - MFR. CODE NUMBER TO MANUFACTURER

Mfr. Code	Manufacturer	Address	City, State, Zip Code
52769	SPRAGUE-GOODMAN ELECTRONICS INC	134 FULTON AVE	GARDEN CITY PARK NY 11040
53387	MINNESOTA MINING AND MFG CO ELECTRONIC PRODUCTS DIV	3M CENTER	ST PAUL MN 55101
54473	MATSUSHITA ELECTRIC CORP OF AMERICA	ONE PANASONIC WAY	SECAUCUS NJ 07094
54583	TDK ELECTRONICS CORP	755 EASTGATE BLVD	GARDEN CITY NY 11530
54937	DEYOUNG MFG INC	1517 130TH AVE NE P O BOX 1806	BELLEVUE WA 98009
55112	WESTLAKE CAPACITORS INC	5334 STERLING CENTER DRIVE	WESTLAKE VILLAGE CA 91361
55680	NICHICON /AMERICA/ CORP	927 E STATE PKY	SCHAUMBURG IL 60195
56289	SPRAGUE ELECTRIC CO	87 MARSHALL ST	NORTH ADAMS MA 01247
57668	RDM CORP	16931 MILLIKEN AVE	IRVINE CA 92713
58224	XENELL CORP	HMY 77 S P O BOX 726	WYNNEWOOD OK 73098
59660	TUSONIX INC	2155 N FORBES BLVD	TUCSON, ARIZONA 85705
59821	CENTRALAB INC SUB NORTH AMERICAN PHILIPS CORP	7158 MERCHANT AVE	EL PASO TX 79915
61271	FUJITSU MICRO ELECTRONICS INC	3320 SCOTT BLVD	SANTA CLARA CA 95051
71400	BUSSMANN MFG CO MCGRAW EDISON CO	114 OLD STATE RD PO BOX 14460	ST LOUIS MO 63178
71744	GENERAL INSTRUMENT CORP LAMP DIV	4433 N RAVENSWOOD AVE	CHICAGO IL 60640
72982	ERIE TECHNOLOGICAL PRODUCTS INC	645 W 11TH ST	ERIE PA 16512
73138	BECKMAN INSTRUMENTS INC HELIPOT DIV	2500 HARBOR BLVD	FULLERTON CA 92634
75042	TRM INC TRM ELECTRONIC COMPONENTS IRC FIXED RESISTORS PHILADELPHIA DIV	401 N BROAD ST	PHILADELPHIA PA 19108
80009	TEKTRONIX INC	4900 S M GRIFFITH DR P O BOX 500	BEAVERTON OR 97077
81483	INTERNATIONAL RECTIFIER	9220 SUNSET BLVD P O BOX 2321 TERMINAL ANNEX	LOS ANGELES CA 90069
81855	EAGLE-PICHER INDUSTRIES INC ELECTRONICS DIV		
91637	DALE ELECTRONICS INC	P O BOX 609	COLUMBUS NE 68601
93410	HAMILTON STANDARD CONTRL ESSEX GROUP INC	45-55 PLYMOUTH ST P O BOX 1007	LEXINGTON OH 44904
54431	MURATA MFG CO LTD	16 KAIJEN NISHIJM CHO	NAGAOKAYO KYOTO JAPAN
1K0515	RIFA WORLD PRODUCTS INC	19678 8TH STREET EAST P O BOX 517	SONOMA CA 95476
TK0935	MARQUARDT SWITCHES INC	MARQUARDT 67 ALBANY ST	CAZENOVIA NY 13035
TK0946	SAN-D INDUSTRIAL CORP	170 MILBUR PL	BAHEMIA, LONG ISLAND NY 11716
TK0961	NEC ELECTRONICS USA INC	401 ELLIS ST	MOUNTAIN VIEW CA 94043
TK1015	MUSASHI WORKS OF HITACHI LTD	1450 JOSUINON-CHO KODAIRA-SHI	TOKYO JAPAN
TK1345	ZMAN AND ASSOCIATES	7633 S 180TH	KENT WA 98032
TK1450	TOKYO COSMOS ELECTRIC CO LTD	2-268 SOBUDAI ZAMA	KANAGAMA 228 JAPAN
TK1544	COMPUTER CONNECTIONS	2427 PRATT AVE	HAYWARD CA 94544
TK1727	PHILIPS NEDERLAND BV AFD ELONCO	POSTBUS 90050	5600 PB EINDHOVEN THE NETHERLANDS
TK2042	ZMAN & ASSOCIATES	7633 SO. 180TH	KENT, WA 98032

2445A Replaceable Electrical Parts
2445A/2455A Service

Component No.	Tektronix Part No.	Serial/Assembly No. Effective Dscont	Name & Description	Mfr. Code	Mfr. Part No.
A1	670-9267-00		CIRCUIT 80 ASSY:MAIN	80009	670-9267-00
A2	672-1037-11		CIRCUIT 80 ASSY:LV PMR SPLY MODULE	80009	672-1037-11
A2A1	-----		CIRCUIT 80 ASSY:REGULATOR (AVAILABLE AT THE 672-1037-XX LEVEL ONLY)		
A3	-----		CIRCUIT 80 ASSY:INVERTER (AVAILABLE AT THE 672-1037-XX LEVEL ONLY)		
A4	670-9493-00		CIRCUIT 80 ASSY:READOUT	80009	670-9493-00
A5	670-9052-00		CIRCUIT 80 ASSY:DIGITAL CONTROL	80009	670-9052-00
A6	614-0448-00		FRONT PNL ASSY:STANDARD	80009	614-0448-00
A6A1	-----		CIRCUIT 80 ASSY:SYNCHRONIZER		
A8	670-7280-00		CIRCUIT 80 ASSY:SCALE ILLUM	80009	670-7280-00
A9	670-7277-08		CIRCUIT 80 ASSY:HIGH VOLTAGE	80009	670-7277-08
A14	670-8000-00		CIRCUIT 80 ASSY:DYNAMIC CENTERING	80009	670-8000-00
A1	670-9267-00		CIRCUIT 80 ASSY:MAIN	80009	670-9267-00
A1A11	119-2342-01		ATTENUATOR,VAR:PRGM 1X-100X,100 STEPS,CH 1	80009	119-2342-01
A1A12	119-2342-02		ATTENUATOR,VAR:PRGM 1X-100X,100 STEPS,CH 2	80009	119-2342-02
A1C100	283-0000-00		CAP,FXD,CER DI:0.001UF,+100-0%,500V (COMBO WITH A1C200)	59660	831-610-Y5U0102P
A1C102	290-0973-00		CAP,FXD,ELCTLT:100UF,20%,25VDC	55680	ULB1E101MEA
A1C103	281-0812-00		CAP,FXD,CER DI:1000PF,10%,100V	04222	MA101C102KAA
A1C105	281-0064-00		CAP,VAR,PLASTIC:0.25-1.5PF,600V	52769	ER-530-013
A1C106	281-0775-01		CAP,FXD,CER DI:0.1UF,20%,50V	04222	MA205E104MAA
A1C107	290-0943-01		CAP,FXD,ELCTLT:47UF,20%,25V	55680	ULB1E470MPAANA1T
A1C108	281-0775-01		CAP,FXD,CER DI:0.1UF,20%,50V	04222	MA205E104MAA
A1C109	281-0909-00		CAP,FXD,CER DI:0.022UF,20%,50V	54583	MA12X7R1H223M-T
A1C110	281-0909-00		CAP,FXD,CER DI:0.022UF,20%,50V	54583	MA12X7R1H223M-T
A1C113	281-0909-00		CAP,FXD,CER DI:0.022UF,20%,50V	54583	MA12X7R1H223M-T
A1C114	290-0943-01		CAP,FXD,ELCTLT:47UF,20%,25V	55680	ULB1E470MPAANA1T
A1C115	281-0761-00		CAP,FXD,CER DI:27PF,5%,100V	04222	MA101A270JAA
A1C116	281-0814-00		CAP,FXD,CER DI:100 PF,10%,100V	04222	MA101A101KAA
A1C117	281-0775-01		CAP,FXD,CER DI:0.1UF,20%,50V	04222	MA205E104MAA
A1C118	281-0205-00		CAP,VAR,PLASTIC:5.5-65 PF,100V	TK1727	2222-808-32659
A1C119	281-0909-00		CAP,FXD,CER DI:0.022UF,20%,50V	54583	MA12X7R1H223M-T
A1C120	281-0909-00		CAP,FXD,CER DI:0.022UF,20%,50V	54583	MA12X7R1H223M-T
A1C121	290-0943-01		CAP,FXD,ELCTLT:47UF,20%,25V	55680	ULB1E470MPAANA1T
A1C125	281-0775-01		CAP,FXD,CER DI:0.1UF,20%,50V	04222	MA205E104MAA
A1C130	290-0776-00		CAP,FXD,ELCTLT:22UF,+50-10%,10V	55680	ULA1A220TEA
A1C152	281-0909-00		CAP,FXD,CER DI:0.022UF,20%,50V	54583	MA12X7R1H223M-T
A1C154	281-0812-00		CAP,FXD,CER DI:1000PF,10%,100V	04222	MA101C102KAA
A1C175	285-1301-01		CAP,FXD,MTLZO:0.47UF,10%,50V	55112	1850.47K50ABB
A1C176	285-1348-00		CAP,FXD,MTLZO:0.22UF,10%,63V	55112	1850.22K63ABB
A1C177	285-1348-00		CAP,FXD,MTLZO:0.22UF,10%,63V	55112	1850.22K63ABB
A1C179	285-1301-01		CAP,FXD,MTLZO:0.47UF,10%,50V	55112	1850.47K50ABB
A1C180	285-1348-00		CAP,FXD,MTLZO:0.22UF,10%,63V	55112	1850.22K63ABB
A1C181	285-1348-00		CAP,FXD,MTLZO:0.22UF,10%,63V	55112	1850.22K63ABB
A1C182	285-1348-00		CAP,FXD,MTLZO:0.22UF,10%,63V	55112	1850.22K63ABB
A1C183	285-1348-00		CAP,FXD,MTLZO:0.22UF,10%,63V	55112	1850.22K63ABB
A1C184	281-0775-01		CAP,FXD,CER DI:0.1UF,20%,50V	04222	MA205E104MAA
A1C185	290-0943-01		CAP,FXD,ELCTLT:47UF,20%,25V	55680	ULB1E470MPAANA1T
A1C200	283-0000-00		CAP,FXD,CER DI:0.001UF,+100-0%,500V (COMBO WITH A1C100)	59660	831-610-Y5U0102P
A1C202	281-0812-00		CAP,FXD,CER DI:1000PF,10%,100V	04222	MA101C102KAA
A1C203	281-0773-00		CAP,FXD,CER DI:0.01UF,10%,100V	04222	MA201C103KAA
A1C205	281-0064-00		CAP,VAR,PLASTIC:0.25-1.5PF,600V	52769	ER-530-013
A1C207	281-0909-00		CAP,FXD,CER DI:0.022UF,20%,50V	54583	MA12X7R1H223M-T
A1C209	281-0909-00		CAP,FXD,CER DI:0.022UF,20%,50V	54583	MA12X7R1H223M-T
A1C210	281-0909-00		CAP,FXD,CER DI:0.022UF,20%,50V	54583	MA12X7R1H223M-T
A1C211	281-0909-00		CAP,FXD,CER DI:0.022UF,20%,50V	54583	MA12X7R1H223M-T

2445A Replaceable Electrical Parts
2445A/2455A Service

Component No.	Tektronix Part No.	Serial/Assembly No. Effective Dscont	Name & Description	Mfr. Code	Mfr. Part No.
A1C217	281-0775-01		CAP,FXD,CER DI:0.1UF,20%,50V	04222	MA205E104MAA
A1C218	290-0943-01		CAP,FXD,ELCTLT:47UF,20%,25V	55680	ULB1E470MPAANA1T
A1C219	281-0775-01		CAP,FXD,CER DI:0.1UF,20%,50V	04222	MA205E104MAA
A1C220	281-0775-01		CAP,FXD,CER DI:0.1UF,20%,50V	04222	MA205E104MAA
A1C221	290-0943-01		CAP,FXD,ELCTLT:47UF,20%,25V	55680	ULB1E470MPAANA1T
A1C223	281-0812-00		CAP,FXD,CER DI:1000PF,10%,100V	04222	MA101C102KAA
A1C225	281-0775-01		CAP,FXD,CER DI:0.1UF,20%,50V	04222	MA205E104MAA
A1C301	281-0775-01		CAP,FXD,CER DI:0.1UF,20%,50V	04222	MA205E104MAA
A1C302	281-0775-01		CAP,FXD,CER DI:0.1UF,20%,50V	04222	MA205E104MAA
A1C307	290-0943-01		CAP,FXD,ELCTLT:47UF,20%,25V	55680	ULB1E470MPAANA1T
A1C310	281-0909-00		CAP,FXD,CER DI:0.022UF,20%,50V	54583	MA12X7R1H223M-T
A1C311	281-0909-00		CAP,FXD,CER DI:0.022UF,20%,50V	54583	MA12X7R1H223M-T
A1C325	290-0943-01		CAP,FXD,ELCTLT:47UF,20%,25V	55680	ULB1E470MPAANA1T
A1C329	281-0773-00		CAP,FXD,CER DI:0.01UF,10%,100V	04222	MA201C103KAA
A1C332	281-0773-00		CAP,FXD,CER DI:0.01UF,10%,100V	04222	MA201C103KAA
A1C336	290-0943-01		CAP,FXD,ELCTLT:47UF,20%,25V	55680	ULB1E470MPAANA1T
A1C351	281-0909-00		CAP,FXD,CER DI:0.022UF,20%,50V	54583	MA12X7R1H223M-T
A1C402	281-0762-00		CAP,FXD,CER DI:27PF,20%,100V	04222	MA101A270MAA
A1C403	281-0218-00		CAP,VAR,CER DI:1-5PF,+2 -2.5%,100V	59660	513-011A1-5
A1C404	281-0218-00		CAP,VAR,CER DI:1-5PF,+2 -2.5%,100V	59660	513-011A1-5
A1C412	281-0762-00		CAP,FXD,CER DI:27PF,20%,100V	04222	MA101A270MAA
A1C415	281-0909-00		CAP,FXD,CER DI:0.022UF,20%,50V	54583	MA12X7R1H223M-T
A1C458	281-0909-00		CAP,FXD,CER DI:0.022UF,20%,50V	54583	MA12X7R1H223M-T
A1C460	281-0909-00		CAP,FXD,CER DI:0.022UF,20%,50V	54583	MA12X7R1H223M-T
A1C464	281-0763-00		CAP,FXD,CER DI:47PF,10%,100V	04222	MA101A470KAA
A1C466	281-0763-00		CAP,FXD,CER DI:47PF,10%,100V	04222	MA101A470KAA
A1C478	281-0759-00		CAP,FXD,CER DI:22PF,10%,100V	04222	MA101A220KAA
A1C480	281-0775-01		CAP,FXD,CER DI:0.1UF,20%,50V	04222	MA205E104MAA
A1C487	281-0823-00		CAP,FXD,CER DI:470PF,10%,50V	04222	MA105A471KAA
A1C488	281-0814-00		CAP,FXD,CER DI:100 PF,10%,100V	04222	MA101A101KAA
A1C500	281-0909-00		CAP,FXD,CER DI:0.022UF,20%,50V	54583	MA12X7R1H223M-T
A1C501	281-0909-00		CAP,FXD,CER DI:0.022UF,20%,50V	54583	MA12X7R1H223M-T
A1C512	290-0246-00		CAP,FXD,ELCTLT:3.3UF,10%,15V	12954	D3R3EA15K1
A1C513	285-1301-01		CAP,FXD,MTLZD:0.47UF,10%,50V	55112	1850.47K50A88
A1C520	281-0814-00		CAP,FXD,CER DI:100 PF,10%,100V	04222	MA101A101KAA
A1C521	281-0909-00		CAP,FXD,CER DI:0.022UF,20%,50V	54583	MA12X7R1H223M-T
A1C528	281-0775-01		CAP,FXD,CER DI:0.1UF,20%,50V	04222	MA205E104MAA
A1C536	290-0246-00		CAP,FXD,ELCTLT:3.3UF,10%,15V	12954	D3R3EA15K1
A1C537	281-0812-00		CAP,FXD,CER DI:1000PF,10%,100V	04222	MA101C102KAA
A1C544	281-0814-00		CAP,FXD,CER DI:100 PF,10%,100V	04222	MA101A101KAA
A1C601	281-0270-00		CAP,VAR,CER DI:9-90PF,50V	51406	TZ03R900E
A1C617	281-0773-00		CAP,FXD,CER DI:0.01UF,10%,100V	04222	MA201C103KAA
A1C625	281-0909-00		CAP,FXD,CER DI:0.022UF,20%,50V	54583	MA12X7R1H223M-T
A1C645	281-0773-00		CAP,FXD,CER DI:0.01UF,10%,100V	04222	MA201C103KAA
A1C650	281-0823-00		CAP,FXD,CER DI:470PF,10%,50V	04222	MA105A471KAA
A1C653	281-0819-00		CAP,FXD,CER DI:33 PF,5%,50V	04222	GC105A330J
A1C660	281-0851-00		CAP,FXD,CER DI:180PF,5%,100VDC	04222	MA101A181JAA
A1C669	281-0775-01		CAP,FXD,CER DI:0.1UF,20%,50V	04222	MA205E104MAA
A1C675	281-0775-01		CAP,FXD,CER DI:0.1UF,20%,50V	04222	MA205E104MAA
A1C707	281-0808-00		CAP,FXD,CER DI:7 PF,20%,100V	04222	MA101A7R04AA
A1C708	285-0676-01		CAP,FXD,PLASTIC:0.1UF,3,5%,35V	80009	285-0676-01
A1C709	285-1060-00		CAP,FXD,PLASTIC:10UF,3%,25V	80009	285-1060-00
A1C710	281-0775-01		CAP,FXD,CER DI:0.1UF,20%,50V	04222	MA205E104MAA
A1C712	285-1301-01		CAP,FXD,MTLZD:0.47UF,10%,50V	55112	1850.47K50A88
A1C722	281-0909-00		CAP,FXD,CER DI:0.022UF,20%,50V	54583	MA12X7R1H223M-T
A1C723	290-0943-01		CAP,FXD,ELCTLT:47UF,20%,25V	55680	ULB1E470MPAANA1T
A1C730	281-0909-00		CAP,FXD,CER DI:0.022UF,20%,50V	54583	MA12X7R1H223M-T
A1C731	290-0944-00		CAP,FXD,ELCTLT:220UF,+50-10%,10V	55680	ULB1A221TPAANA
A1C732	290-0944-00		CAP,FXD,ELCTLT:220UF,+50-10%,10V	55680	ULB1A221TPAANA

2445A Replaceable Electrical Parts
2445A/2455A Service

Component No.	Tektronix Part No.	Serial/Assembly No. Effective Dscont	Name & Description	Mfr. Code	Mfr. Part No.
A1C733	290-0943-01		CAP, FXD, ELCTLT:47UF, 20%, 25V	55680	ULB1E470MPAANA1T
A1C735	281-0823-00		CAP, FXD, CER DI:470PF, 10%, 50V	04222	MA105A471KAA
A1C738	290-0943-01		CAP, FXD, ELCTLT:47UF, 20%, 25V	55680	ULB1E470MPAANA1T
A1C740	290-0943-01		CAP, FXD, ELCTLT:47UF, 20%, 25V	55680	ULB1E470MPAANA1T
A1C742	281-0812-00		CAP, FXD, CER DI:1000PF, 10%, 100V	04222	MA101C102KAA
A1C803	281-0909-00		CAP, FXD, CER DI:0.022UF, 20%, 50V	54583	MA12X7R1H223M-T
A1C804	281-0797-00		CAP, FXD, CER DI:15PF, 10%, 100V	04222	MA106A150KAA
A1C805	281-0823-00		CAP, FXD, CER DI:470PF, 10%, 50V	04222	MA105A471KAA
A1C806	283-0156-00		CAP, FXD, CER DI:0.001 UF, +80-20%, 200V	05397	C315C102Z2R5CA
A1C808	281-0757-00		CAP, FXD, CER DI:10PF, 20%, 100V	04222	MA101A100MAA
A1C809	281-0819-00		CAP, FXD, CER DI:33 PF, 5%, 50V	04222	GC105A330J
A1C810	281-0909-00		CAP, FXD, CER DI:0.022UF, 20%, 50V	54583	MA12X7R1H223M-T
A1C811	281-0909-00		CAP, FXD, CER DI:0.022UF, 20%, 50V	54583	MA12X7R1H223M-T
A1C817	281-0812-00		CAP, FXD, CER DI:1000PF, 10%, 100V	04222	MA101C102KAA
A1C819	281-0909-00		CAP, FXD, CER DI:0.022UF, 20%, 50V	54583	MA12X7R1H223M-T
A1C822	281-0775-01		CAP, FXD, CER DI:0.1UF, 20%, 50V	04222	MA205E104MAA
A1C823	281-0909-00		CAP, FXD, CER DI:0.022UF, 20%, 50V	54583	MA12X7R1H223M-T
A1C830	281-0812-00		CAP, FXD, CER DI:1000PF, 10%, 100V	04222	MA101C102KAA
A1C848	281-0909-00		CAP, FXD, CER DI:0.022UF, 20%, 50V	54583	MA12X7R1H223M-T
A1C849	281-0775-01		CAP, FXD, CER DI:0.1UF, 20%, 50V	04222	MA205E104MAA
A1C850	281-0909-00		CAP, FXD, CER DI:0.022UF, 20%, 50V	54583	MA12X7R1H223M-T
A1C851	285-1301-01		CAP, FXD, MTLZD:0.47UF, 10%, 50V	55112	1850.47K50A8B
A1C852	285-1301-01		CAP, FXD, MTLZD:0.47UF, 10%, 50V	55112	1850.47K50A8B
A1C853	285-1301-01		CAP, FXD, MTLZD:0.47UF, 10%, 50V	55112	1850.47K50A8B
A1C854	285-1301-01		CAP, FXD, MTLZD:0.47UF, 10%, 50V	55112	1850.47K50A8B
A1C903	281-0909-00		CAP, FXD, CER DI:0.022UF, 20%, 50V	54583	MA12X7R1H223M-T
A1C907	281-0808-00		CAP, FXD, CER DI:7 PF, 20%, 100V	04222	MA101A7R04AA
A1C908	285-0752-03		CAP, FXD, PLASTIC:1UF, 3%, 50V	80009	285-0752-03
A1C912	281-0909-00		CAP, FXD, CER DI:0.022UF, 20%, 50V	54583	MA12X7R1H223M-T
A1C933	281-0909-00		CAP, FXD, CER DI:0.022UF, 20%, 50V	54583	MA12X7R1H223M-T
A1C938	281-0909-00		CAP, FXD, CER DI:0.022UF, 20%, 50V	54583	MA12X7R1H223M-T
A1C940	281-0909-00		CAP, FXD, CER DI:0.022UF, 20%, 50V	54583	MA12X7R1H223M-T
A1C941	281-0763-00		CAP, FXD, CER DI:47PF, 10%, 100V	04222	MA101A470KAA
A1C943	281-0909-00		CAP, FXD, CER DI:0.022UF, 20%, 50V	54583	MA12X7R1H223M-T
A1C947	281-0759-00		CAP, FXD, CER DI:22PF, 10%, 100V	04222	MA101A220KAA
A1C957	290-0804-00		CAP, FXD, ELCTLT:10UF, +50-10%, 25V	55680	ULA1E100TEA
A1C958	281-0909-00		CAP, FXD, CER DI:0.022UF, 20%, 50V	54583	MA12X7R1H223M-T
A1C966	281-0783-00		CAP, FXD, CER DI:0.1 UF, 20%, 100V	04222	MA401C104MAA
A1C967	281-0783-00		CAP, FXD, CER DI:0.1 UF, 20%, 100V	04222	MA401C104MAA
A1C972	281-0756-00		CAP, FXD, CER DI:2.2PF, +/-0.5PF, 200V	04222	MA106A2R2DAA
A1C973	281-0909-00		CAP, FXD, CER DI:0.022UF, 20%, 50V	54583	MA12X7R1H223M-T
A1C975	281-0775-01		CAP, FXD, CER DI:0.1UF, 20%, 50V	04222	MA205E104MAA
A1C980	281-0909-00		CAP, FXD, CER DI:0.022UF, 20%, 50V	54583	MA12X7R1H223M-T
A1C982	281-0759-00		CAP, FXD, CER DI:22PF, 10%, 100V	04222	MA101A220KAA
A1C988	281-0909-00		CAP, FXD, CER DI:0.022UF, 20%, 50V	54583	MA12X7R1H223M-T
A1C990	281-0909-00		CAP, FXD, CER DI:0.022UF, 20%, 50V	54583	MA12X7R1H223M-T
A1C995	281-0810-00		CAP, FXD, CER DI:5.6PF, +/-0.5PF, 100V	04222	MA101A5R6DAA
A1CR100	152-0323-01		SEMICONO OVC, DI:SM, SI, 35V, 0.1A, D0-35	14552	WT5127
A1CR101	152-0323-01		SEMICONO OVC, DI:SM, SI, 35V, 0.1A, D0-35	14552	WT5127
A1CR107	152-0066-00		SEMICONO OVC, DI:RECT, SI, 400V, 1A, D0-41	05828	GP10G-020
A1CR130	152-0141-02		SEMICONO OVC, DI:SM, SI, 30V, 150MA, 30V, D0-35	03508	0A2527 (1N4152)
A1CR131	152-0141-02		SEMICONO OVC, DI:SM, SI, 30V, 150MA, 30V, D0-35	03508	0A2527 (1N4152)
A1CR140	152-0141-02		SEMICONO OVC, DI:SM, SI, 30V, 150MA, 30V, D0-35	03508	0A2527 (1N4152)
A1CR141	152-0141-02		SEMICONO OVC, DI:SM, SI, 30V, 150MA, 30V, D0-35	03508	0A2527 (1N4152)
A1CR142	152-0141-02		SEMICONO OVC, DI:SM, SI, 30V, 150MA, 30V, D0-35	03508	0A2527 (1N4152)
A1CR143	152-0141-02		SEMICONO OVC, DI:SM, SI, 30V, 150MA, 30V, D0-35	03508	0A2527 (1N4152)
A1CR144	152-0141-02		SEMICONO OVC, DI:SM, SI, 30V, 150MA, 30V, D0-35	03508	0A2527 (1N4152)
A1CR145	152-0141-02		SEMICONO OVC, DI:SM, SI, 30V, 150MA, 30V, D0-35	03508	0A2527 (1N4152)
A1CR146	152-0141-02		SEMICONO OVC, DI:SM, SI, 30V, 150MA, 30V, D0-35	03508	0A2527 (1N4152)

2445A Replaceable Electrical Parts
2445A/2455A Service

Component No.	Tektronix Part No.	Serial/Assembly No. Effective Dscont	Name & Description	Mfr. Code	Mfr. Part No.
A1CR147	152-0141-02		SEMICON DVC,DI:SM,SI,30V,150MA,30V,00-35	03508	DA2527 (1N4152)
A1CR148	152-0141-02		SEMICON DVC,DI:SM,SI,30V,150MA,30V,00-35	03508	DA2527 (1N4152)
A1CR149	152-0141-02		SEMICON DVC,DI:SM,SI,30V,150MA,30V,00-35	03508	DA2527 (1N4152)
A1CR150	152-0141-02		SEMICON DVC,DI:SM,SI,30V,150MA,30V,00-35	03508	DA2527 (1N4152)
A1CR151	152-0141-02		SEMICON DVC,DI:SM,SI,30V,150MA,30V,00-35	03508	DA2527 (1N4152)
A1CR152	152-0141-02		SEMICON DVC,DI:SM,SI,30V,150MA,30V,00-35	03508	DA2527 (1N4152)
A1CR153	152-0141-02		SEMICON DVC,DI:SM,SI,30V,150MA,30V,00-35	03508	DA2527 (1N4152)
A1CR154	152-0141-02		SEMICON DVC,DI:SM,SI,30V,150MA,30V,00-35	03508	DA2527 (1N4152)
A1CR155	152-0141-02		SEMICON DVC,DI:SM,SI,30V,150MA,30V,00-35	03508	DA2527 (1N4152)
A1CR161	152-0141-02		SEMICON DVC,DI:SM,SI,30V,150MA,30V,00-35	03508	DA2527 (1N4152)
A1CR162	152-0141-02		SEMICON DVC,DI:SM,SI,30V,150MA,30V,00-35	03508	DA2527 (1N4152)
A1CR163	152-0141-02		SEMICON DVC,DI:SM,SI,30V,150MA,30V,00-35	03508	DA2527 (1N4152)
A1CR180	152-0141-02		SEMICON DVC,DI:SM,SI,30V,150MA,30V,00-35	03508	DA2527 (1N4152)
A1CR181	152-0141-02		SEMICON DVC,DI:SM,SI,30V,150MA,30V,00-35	03508	DA2527 (1N4152)
A1CR200	152-0323-01		SEMICON DVC,DI:SM,SI,35V,0.1A,00-35	14552	MT5127
A1CR201	152-0323-01		SEMICON DVC,DI:SM,SI,35V,0.1A,00-35	14552	MT5127
A1CR354	152-0141-02		SEMICON DVC,DI:SM,SI,30V,150MA,30V,00-35	03508	DA2527 (1N4152)
A1CR360	152-0141-02		SEMICON DVC,DI:SM,SI,30V,150MA,30V,00-35	03508	DA2527 (1N4152)
A1CR460	152-0141-02		SEMICON DVC,DI:SM,SI,30V,150MA,30V,00-35	03508	DA2527 (1N4152)
A1CR461	152-0141-02		SEMICON DVC,DI:SM,SI,30V,150MA,30V,00-35	03508	DA2527 (1N4152)
A1CR476	152-0141-02		SEMICON DVC,DI:SM,SI,30V,150MA,30V,00-35	03508	DA2527 (1N4152)
A1CR484	152-0141-02		SEMICON DVC,DI:SM,SI,30V,150MA,30V,00-35	03508	DA2527 (1N4152)
A1CR485	152-0141-02		SEMICON DVC,DI:SM,SI,30V,150MA,30V,00-35	03508	DA2527 (1N4152)
A1CR495	152-0141-02		SEMICON DVC,DI:SM,SI,30V,150MA,30V,00-35	03508	DA2527 (1N4152)
A1CR503	152-0141-02		SEMICON DVC,DI:SM,SI,30V,150MA,30V,00-35	03508	DA2527 (1N4152)
A1CR538	152-0141-02		SEMICON DVC,DI:SM,SI,30V,150MA,30V,00-35	03508	DA2527 (1N4152)
A1CR539	152-0141-02		SEMICON DVC,DI:SM,SI,30V,150MA,30V,00-35	03508	DA2527 (1N4152)
A1CR600	152-0141-02		SEMICON DVC,DI:SM,SI,30V,150MA,30V,00-35	03508	DA2527 (1N4152)
A1CR601	152-0141-02		SEMICON DVC,DI:SM,SI,30V,150MA,30V,00-35	03508	DA2527 (1N4152)
A1CR616	152-0141-02		SEMICON DVC,DI:SM,SI,30V,150MA,30V,00-35	03508	DA2527 (1N4152)
A1CR619	152-0141-02		SEMICON DVC,DI:SM,SI,30V,150MA,30V,00-35	03508	DA2527 (1N4152)
A1CR620	152-0141-02		SEMICON DVC,DI:SM,SI,30V,150MA,30V,00-35	03508	DA2527 (1N4152)
A1CR621	152-0141-02		SEMICON DVC,DI:SM,SI,30V,150MA,30V,00-35	03508	DA2527 (1N4152)
A1CR652	152-0141-02		SEMICON DVC,DI:SM,SI,30V,150MA,30V,00-35	03508	DA2527 (1N4152)
A1CR653	152-0141-02		SEMICON DVC,DI:SM,SI,30V,150MA,30V,00-35	03508	DA2527 (1N4152)
A1CR707	152-0141-02		SEMICON DVC,DI:SM,SI,30V,150MA,30V,00-35	03508	DA2527 (1N4152)
A1CR741	152-0141-02		SEMICON DVC,DI:SM,SI,30V,150MA,30V,00-35	03508	DA2527 (1N4152)
A1CR746	152-0141-02		SEMICON DVC,DI:SM,SI,30V,150MA,30V,00-35	03508	DA2527 (1N4152)
A1CR747	152-0141-02		SEMICON DVC,DI:SM,SI,30V,150MA,30V,00-35	03508	DA2527 (1N4152)
A1CR752	152-0075-00		SEMICON DVC,DI:SM,GE,22V,80MH,00-7	14433	G866
A1CR807	152-0574-00		SEMICON DVC,DI:SM,SI,120V,0.15A,00-35	12969	NDP566
A1CR811	152-0141-02		SEMICON DVC,DI:SM,SI,30V,150MA,30V,00-35	03508	DA2527 (1N4152)
A1CR850	152-0141-02		SEMICON DVC,DI:SM,SI,30V,150MA,30V,00-35	03508	DA2527 (1N4152)
A1CR950	152-0141-02		SEMICON DVC,DI:SM,SI,30V,150MA,30V,00-35	03508	DA2527 (1N4152)
A1CR951	152-0141-02		SEMICON DVC,DI:SM,SI,30V,150MA,30V,00-35	03508	DA2527 (1N4152)
A1CR956	152-0141-02		SEMICON DVC,DI:SM,SI,30V,150MA,30V,00-35	03508	DA2527 (1N4152)
A1CR966	152-0574-00		SEMICON DVC,DI:SM,SI,120V,0.15A,00-35	12969	NDP566
A1CR972	152-0574-00		SEMICON DVC,DI:SM,SI,120V,0.15A,00-35	12969	NDP566
A1CR982	152-0141-02		SEMICON DVC,DI:SM,SI,30V,150MA,30V,00-35	03508	DA2527 (1N4152)
A1CR987	152-0574-00		SEMICON DVC,DI:SM,SI,120V,0.15A,00-35	12969	NDP566
A1CR995	152-0061-00		SEMICON DVC,DI:SM,SI,175V,0.1A,00-35	07263	FDH2161
A1DL100	119-1490-00		DELAY LINE,ELEC:73NS,150 OHM	80009	119-1490-00
A1E940	276-0507-00		SHLD BEAD,ELEK:FERRITE	02114	56-590-658/38
A1E980	276-0507-00		SHLD BEAD,ELEK:FERRITE	02114	56-590-658/38
A1J9	131-0608-00		TERMINAL,PIN:0.365 L X 0.025 BRZ GLD PL	22526	48283-036
A1J10	131-0608-00		TERMINAL,PIN:0.365 L X 0.025 BRZ GLD PL (QUANTITY OF 3)	22526	48283-036
A1J11	131-0608-00		TERMINAL,PIN:0.365 L X 0.025 BRZ GLD PL (QUANTITY OF 3)	22526	48283-036

2445A Replaceable Electrical Parts
2445A/2455A Service

Component No.	Tektronix Part No.	Serial/Assembly No. Effective Dscont	Name & Description	Mfr. Code	Mfr. Part No.
A1J100	131-0608-00		TERMINAL,PIN:0.365 L X 0.025 BRZ GLD PL (QUANTITY OF 2)	22526	48283-036
A1J101	131-3520-00		CONN,RCPT,ELEC:HDR,10 CONT,STR SLDR PIN	53387	3591-6002
A1J102	131-3520-00		CONN,RCPT,ELEC:HDR,10 CONT,STR SLDR PIN	53387	3591-6002
A1J103	131-2921-00		CONN,RCPT,ELEC:HEADER,1 X 2,0.1 SPACING	00779	1-86479-3
A1J104	131-0608-00		TERMINAL,PIN:0.365 L X 0.025 BRZ GLD PL (QUANTITY OF 4)	22526	48283-036
A1J105	131-0608-00		TERMINAL,PIN:0.365 L X 0.025 BRZ GLD PL (QUANTITY OF 2)	22526	48283-036
A1J109	131-0608-00		TERMINAL,PIN:0.365 L X 0.025 BRZ GLD PL (QUANTITY OF 2)	22526	48283-036
A1J117	131-0608-00		TERMINAL,PIN:0.365 L X 0.025 BRZ GLD PL	22526	48283-036
A1J120	131-3152-00		CONN,RCPT,ELEC:HEADER,2 X 8 0.1 SPACING	22526	75867-003
A1J181	131-0608-00		TERMINAL,PIN:0.365 L X 0.025 BRZ GLD PL (QUANTITY OF 2)	22526	48283-036
A1J411	131-3362-00		CONN,RCPT,ELEC:HEADER,STR,26 PIN	53387	3593-6002
A1J511	131-3362-00		CONN,RCPT,ELEC:HEADER,STR,26 PIN	53387	3593-6002
A1J512	131-3364-00		CONN,RCPT,ELEC:HEADER,STRAIGHT,34 PIN	53387	3594-6002
A1L101	108-1251-00		COIL,RF:FXD,2.7UH,10%	54583	SPT 0406-2R7K-6
A1L107	108-1251-00		COIL,RF:FXD,2.7UH,10%	54583	SPT 0406-2R7K-6
A1L113	108-1251-00		COIL,RF:FXD,2.7UH,10%	54583	SPT 0406-2R7K-6
A1L115	108-0317-00		COIL,RF:FIXED,15 UH	32159	71501M+10PERCENT
A1L120	108-1251-00		COIL,RF:FXD,2.7UH,10%	54583	SPT 0406-2R7K-6
A1L219	108-1251-00		COIL,RF:FXD,2.7UH,10%	54583	SPT 0406-2R7K-6
A1L220	108-1251-00		COIL,RF:FXD,2.7UH,10%	54583	SPT 0406-2R7K-6
A1L307	108-1251-00		COIL,RF:FXD,2.7UH,10%	54583	SPT 0406-2R7K-6
A1L325	108-1251-00		COIL,RF:FXD,2.7UH,10%	54583	SPT 0406-2R7K-6
A1L336	108-1251-00		COIL,RF:FXD,2.7UH,10%	54583	SPT 0406-2R7K-6
A1L521	108-1251-00		COIL,RF:FXD,2.7UH,10%	54583	SPT 0406-2R7K-6
A1L605	108-0170-01		COIL,RF:FIXED,360NH	TK2042	ORDER BY DESCR
A1L606	108-0736-00		COIL,RF:FIXED,810NH	TK2042	ORDER BY DESCR
A1L607	108-0736-00		COIL,RF:FIXED,810NH	TK2042	ORDER BY DESCR
A1L608	108-0170-01		COIL,RF:FIXED,360NH	TK2042	ORDER BY DESCR
A1L609	108-0509-00		COIL,RF:FIXED,2.45UH	TK2042	ORDER BY DESCR
A1L610	108-0509-00		COIL,RF:FIXED,2.45UH	TK2042	ORDER BY DESCR
A1L619	108-0736-00		COIL,RF:FIXED,810NH	TK2042	ORDER BY DESCR
A1L628	108-0327-00		COIL,RF:FIXED,48NH	TK2042	ORDER BY DESCR
A1L633	108-0327-00		COIL,RF:FIXED,48NH	TK2042	ORDER BY DESCR
A1L644	114-0353-00		COIL,RF:VARIABLE,0.6-1.0UH	80009	114-0353-00
A1L733	108-1251-00		COIL,RF:FXD,2.7UH,10%	54583	SPT 0406-2R7K-6
A1L738	108-0317-00		COIL,RF:FIXED,15 UH	32159	71501M+10PERCENT
A1L740	108-0317-00		COIL,RF:FIXED,15 UH	32159	71501M+10PERCENT
A1L743	108-1251-00		COIL,RF:FXD,2.7UH,10%	54583	SPT 0406-2R7K-6
A1L938	108-1251-00		COIL,RF:FXD,2.7UH,10%	54583	SPT 0406-2R7K-6
A1L973	108-1251-00		COIL,RF:FXD,2.7UH,10%	54583	SPT 0406-2R7K-6
A1LR101	108-0325-00		COIL,RF:FIXED,490NH	TK2042	ORDER BY DESCR
A1LR107	108-0325-00		COIL,RF:FIXED,490NH	TK2042	ORDER BY DESCR
A1LR201	108-0325-00		COIL,RF:FIXED,490NH	TK2042	ORDER BY DESCR
A1LR218	108-0330-00		COIL,RF:FIXED,395NH	TK2042	ORDER BY DESCR
A1LR219	108-0330-00		COIL,RF:FIXED,395NH	TK2042	ORDER BY DESCR
A1Q130	151-0622-00		TRANSISTOR:PNP,SI,TO-92	04713	SPS8956(MPSM51A)
A1Q131	151-0622-00		TRANSISTOR:PNP,SI,TO-92	04713	SPS8956(MPSM51A)
A1Q154	151-0188-00		TRANSISTOR:PNP,SI,TO-92	80009	151-0188-00
A1Q155	151-0188-00		TRANSISTOR:PNP,SI,TO-92	80009	151-0188-00
A1Q190	151-0190-00		TRANSISTOR:NPN,SI,TO-92	80009	151-0190-00
A1Q460	151-0198-01		TRANSISTOR:NPN,SI,TO-92 PLSTC (QUANTITY OF 2,LOCATIONS A & B)	80009	151-0198-01
A1Q550	151-0190-00		TRANSISTOR:NPN,SI,TO-92	80009	151-0190-00
A1Q600	151-0190-00		TRANSISTOR:NPN,SI,TO-92	80009	151-0190-00
A1Q623	151-0190-00		TRANSISTOR:NPN,SI,TO-92	80009	151-0190-00

2445A Replaceable Electrical Parts
2445A/2455A Service

Component No.	Tektronix Part No.	Serial/Assembly No. Effective Dscont	Name & Description	Mfr. Code	Mfr. Part No.
A1Q624	151-1025-00		TRANSISTOR:FET,N-CHAN,SI,TO-92	04713	SPF3036
A1Q645	151-0188-00		TRANSISTOR:PMP,SI,TO-92	80009	151-0188-00
A1Q700	151-0190-00		TRANSISTOR:NPN,SI,TO-92	80009	151-0190-00
A1Q709	151-0736-01		TRANSISTOR:NPN,SI,TO-92	80009	151-0736-01
A1Q710	151-0736-01		TRANSISTOR:NPN,SI,TO-92	80009	151-0736-01
A1Q741	151-0188-00		TRANSISTOR:PMP,SI,TO-92	80009	151-0188-00
A1R100	315-0474-00		RES,FXD,FILM:470K OHM,5%,0.25M	19701	5043CX470K0J92U
A1R101	315-0272-00		RES,FXD,FILM:2.7K OHM,5%,0.25M	57668	NTR25J-E02K7
A1R102	315-0272-00		RES,FXD,FILM:2.7K OHM,5%,0.25M	57668	NTR25J-E02K7
A1R112	313-1101-00		RES,FXD,FILM:100 OHM,5%,0.2M	57668	TR20JE100E
A1R114	321-0130-03		RES,FXD,FILM:221 OHM,0.25%,0.125M,TC=T2 MI	91637	MFF1816D221R0C
A1R115	321-0146-00		RES,FXD,FILM:324 OHM,1%,0.125M,TC=TO	07716	CEAD324R0F
A1R117	321-0320-00		RES,FXD,FILM:21.0K OHM,1%,0.125M,TC=TO	19701	5033E021K00F
A1R118	321-0212-00		RES,FXD,FILM:1.58K OHM,1%,0.125M,TC=70	19701	5033E01K58F
A1R121	315-0121-00		RES,FXD,FILM:120 OHM,5%,0.25M	19701	5043CX120R0J
A1R123	315-0622-00		RES,FXD,FILM:6.2K OHM,5%,0.25M	19701	5043CX6K200J
A1R125	301-0361-00		RES,FXD,FILM:360 OHM,5%,0.5M	19701	5053CX360R0J
A1R129	315-0101-00		RES,FXD,FILM:100 OHM,5%,0.25M	57668	NTR25J-E 100E
A1R130	315-0561-00		RES,FXD,FILM:560 OHM,5%,0.25M	19701	5043CX560R0J
A1R131	315-0561-00		RES,FXD,FILM:560 OHM,5%,0.25M	19701	5043CX560R0J
A1R133	315-0122-00		RES,FXD,FILM:1.2K OHM,5%,0.25M	57668	NTR25J-E01K2
A1R135	315-0102-00		RES,FXD,FILM:1K OHM,5%,0.25M	57668	NTR25JE01K0
A1R136	315-0622-00		RES,FXD,FILM:6.2K OHM,5%,0.25M	19701	5043CX6K200J
A1R140	315-0471-00		RES,FXD,FILM:470 OHM,5%,0.25M	57668	NTR25J-E470E
A1R141	315-0471-00		RES,FXD,FILM:470 OHM,5%,0.25M	57668	NTR25J-E470E
A1R142	315-0391-00		RES,FXD,FILM:390 OHM,5%,0.25M	57668	NTR25J-E390E
A1R143	315-0391-00		RES,FXD,FILM:390 OHM,5%,0.25M	57668	NTR25J-E390E
A1R144	307-0108-00		RES,FXD,CMPSN:6.8 OHM,5%,0.25M	01121	CB68G5
A1R149	315-0103-00		RES,FXD,FILM:10K OHM,5%,0.25M	19701	5043CX10K00J
A1R152	315-0562-00		RES,FXD,FILM:5.6K OHM,5%,0.25M	57668	NTR25J-E05K6
A1R153	315-0752-00		RES,FXD,FILM:7.5K OHM,5%,0.25M	57668	NTR25J-E07K5
A1R154	321-0210-00		RES,FXD,FILM:1.50K OHM,1%,0.125M,TC=TO	19701	5033E01K50F
A1R155	321-0206-00		RES,FXD,FILM:1.37K OHM,1%,0.125M,TC=TO	07716	CEAD13700F
A1R156	321-0255-00		RES,FXD,FILM:4.42K OHM,1%,0.125M,TC=TO	19701	5033E04K420F
A1R159	321-0242-00		RES,FXD,FILM:3.24K OHM,1%,0.125M,TC=TO	19701	5043E03K240F
A1R161	321-0293-00		RES,FXD,FILM:11.0K OHM,1%,0.125M,TC=TO	07716	CEAD11001F
A1R162	321-0293-00		RES,FXD,FILM:11.0K OHM,1%,0.125M,TC=TO	07716	CEAD11001F
A1R163	321-0242-00		RES,FXD,FILM:3.24K OHM,1%,0.125M,TC=TO	19701	5043E03K240F
A1R165	313-1822-00		RES,FXD,FILM:8.2K OHM,5%,0.2M	57668	TR20JE 08K2
A1R180	322-3242-00		RES,FXD,FILM:3.24K OHM,1%,0.2M,TC=TO	57668	CR820 FXE 3K24
A1R181	322-3289-00		RES,FXD,FILM:10K OHM,1%,0.2M,TC=TO	57668	CR820 FXE 10K0
A1R182	322-3242-00		RES,FXD,FILM:3.24K OHM,1%,0.2M,TC=TO	57668	CR820 FXE 3K24
A1R183	322-3289-00		RES,FXD,FILM:10K OHM,1%,0.2M,TC=TO	57668	CR820 FXE 10K0
A1R190	315-0103-00		RES,FXD,FILM:10K OHM,5%,0.25M	19701	5043CX10K00J
A1R191	315-0103-00		RES,FXD,FILM:10K OHM,5%,0.25M	19701	5043CX10K00J
A1R192	315-0103-00		RES,FXD,FILM:10K OHM,5%,0.25M	19701	5043CX10K00J
A1R193	315-0102-00		RES,FXD,FILM:1K OHM,5%,0.25M	57668	NTR25JE01K0
A1R194	315-0103-00		RES,FXD,FILM:10K OHM,5%,0.25M	19701	5043CX10K00J
A1R195	315-0301-00		RES,FXD,FILM:300 OHM,5%,0.25M	57668	NTR25J-E300E
A1R196	315-0752-00		RES,FXD,FILM:7.5K OHM,5%,0.25M	57668	NTR25J-E07K5
A1R197	315-0562-00		RES,FXD,FILM:5.6K OHM,5%,0.25M	57668	NTR25J-E05K6
A1R198	321-1700-04		RES,FXD,FILM:10.44K OHM,0.1%,0.125M,TC=T2	19701	5033RC10K440B
A1R199	321-1700-04		RES,FXD,FILM:10.44K OHM,0.1%,0.125M,TC=T2	19701	5033RC10K440B
A1R200	315-0474-00		RES,FXD,FILM:470K OHM,5%,0.25M	19701	5043CX470K0J92U
A1R201	315-0272-00		RES,FXD,FILM:2.7K OHM,5%,0.25M	57668	NTR25J-E02K7
A1R202	315-0272-00		RES,FXD,FILM:2.7K OHM,5%,0.25M	57668	NTR25J-E02K7
A1R216	315-0121-00		RES,FXD,FILM:120 OHM,5%,0.25M	19701	5043CX120R0J
A1R217	321-0320-00		RES,FXD,FILM:21.0K OHM,1%,0.125M,TC=TO	19701	5033E021K00F
A1R218	321-0212-00		RES,FXD,FILM:1.58K OHM,1%,0.125M,TC=70	19701	5033E01K58F

2445A Replaceable Electrical Parts
2445A/2455A Service

Component No.	Tektronix Part No.	Serial/Assembly No. Effective	Discont	Name & Description	Mfr. Code	Mfr. Part No.
A1R225	301-0361-00			RES, FXD, FILM:360 OHM, 5%, 0.5M	19701	5053CX360R0J
A1R230	315-0222-00			RES, FXD, FILM:2.2K OHM, 5%, 0.25M	57668	NTR25J-ED2K2
A1R231	315-0222-00			RES, FXD, FILM:2.2K OHM, 5%, 0.25M	57668	NTR25J-ED2K2
A1R232	315-0222-00			RES, FXD, FILM:2.2K OHM, 5%, 0.25M	57668	NTR25J-ED2K2
A1R301	315-0240-00			RES, FXD, FILM:24 OHM, 5%, 0.25M	57668	NTR25J-E24E0
A1R302	315-0240-00			RES, FXD, FILM:24 OHM, 5%, 0.25M	57668	NTR25J-E24E0
A1R303	315-0101-00			RES, FXD, FILM:100 OHM, 5%, 0.25M	57668	NTR25J-E 100E
A1R304	315-0101-00			RES, FXD, FILM:100 OHM, 5%, 0.25M	57668	NTR25J-E 100E
A1R311	315-0101-00			RES, FXD, FILM:100 OHM, 5%, 0.25M	57668	NTR25J-E 100E
A1R312	315-0101-00			RES, FXD, FILM:100 OHM, 5%, 0.25M	57668	NTR25J-E 100E
A1R329	315-0101-00			RES, FXD, FILM:100 OHM, 5%, 0.25M	57668	NTR25J-E 100E
A1R332	315-0101-00			RES, FXD, FILM:100 OHM, 5%, 0.25M	57668	NTR25J-E 100E
A1R353	321-0239-00			RES, FXD, FILM:3.01K OHM, 1%, 0.125M, TC=T0	19701	5043ED3K010F
A1R361	321-0265-00			RES, FXD, FILM:5.62K OHM, 1%, 0.125M, TC=T0	19701	5043ED5K620F
A1R401	321-0202-00			RES, FXD, FILM:1.24K OHM, 1%, 0.125M, TC=T0	24546	NA5501241F
A1R402	315-0750-00			RES, FXD, FILM:75 OHM, 5%, 0.25M	57668	NTR25J-E75E0
A1R403	311-0607-00			RES, VAR, NONMM:TRMR, 10K OHM, 0.5M	73138	82-25-2
A1R404	313-1200-00			RES, FXD, FILM:20 OHM, 5%, 0.2M	57668	TR20JE20E
A1R405	313-1200-00			RES, FXD, FILM:20 OHM, 5%, 0.2M	57668	TR20JE20E
A1R410	311-0634-00	8010100	8010126	RES, VAR, NONMM:TRMR, 500 OHM, 0.5M	32997	3329H-L58-501
A1R410	311-0635-00	8010127		RES, VAR, NONMM:TRMR, 1K OHM, 0.5M	32997	3329H-G48-102
A1R412	315-0750-00			RES, FXD, FILM:75 OHM, 5%, 0.25M	57668	NTR25J-E75E0
A1R430	315-0750-00			RES, FXD, FILM:75 OHM, 5%, 0.25M	57668	NTR25J-E75E0
A1R450	321-0310-00			RES, FXD, FILM:16.5K OHM, 1%, 0.125M, TC=T0	19701	5033ED16K50F
A1R451	321-0275-00			RES, FXD, FILM:7.15K OHM, 1%, 0.125M, TC=T0	07716	CEAD71500F
A1R452	321-0310-00			RES, FXD, FILM:16.5K OHM, 1%, 0.125M, TC=T0	19701	5033ED16K50F
A1R453	321-0275-00			RES, FXD, FILM:7.15K OHM, 1%, 0.125M, TC=T0	07716	CEAD71500F
A1R454	321-0310-00			RES, FXD, FILM:16.5K OHM, 1%, 0.125M, TC=T0	19701	5033ED16K50F
A1R455	321-0310-00			RES, FXD, FILM:16.5K OHM, 1%, 0.125M, TC=T0	19701	5033ED16K50F
A1R456	321-0333-00			RES, FXD, FILM:28.7K OHM, 1%, 0.125M, TC=T0	19701	5043ED28K70F
A1R457	321-0275-00			RES, FXD, FILM:7.15K OHM, 1%, 0.125M, TC=T0	07716	CEAD71500F
A1R458	321-0085-00			RES, FXD, FILM:75 OHM, 1%, 0.125M, TC=T0	57668	CRB14FXE 75 OHM
A1R459	321-0085-00			RES, FXD, FILM:75 OHM, 1%, 0.125M, TC=T0	57668	CRB14FXE 75 OHM
A1R460	321-0062-00			RES, FXD, FILM:43.2 OHM, 0.5%, 0.125M, TC=T0	57668	CRB14 FXE 43.2
A1R461	321-0139-00			RES, FXD, FILM:274 OHM, 1%, 0.125M, TC=T0	07716	CEAO274R0F
A1R462	321-0201-00			RES, FXD, FILM:1.21K OHM, 1%, 0.125M, TC=T0	19701	5043ED1K210F
A1R463	321-0193-00			RES, FXD, FILM:1K OHM, 1%, 0.125M, TC=T0	19701	5033ED1K00F
A1R464	321-0063-00			RES, FXD, FILM:44.2 OHM, 0.5%, 0.125M, TC=T0	91637	CMF55116644R20F
A1R465	321-0193-00			RES, FXD, FILM:1K OHM, 1%, 0.125M, TC=T0	19701	5033ED1K00F
A1R468	321-0287-00			RES, FXD, FILM:9.53K OHM, 1%, 0.125M, TC=T0	19701	5033ED9K530F
A1R469	315-0200-00			RES, FXD, FILM:20 OHM, 5%, 0.25M	19701	5043CX20R00J
A1R470	315-0223-00			RES, FXD, FILM:22K OHM, 5%, 0.25M	19701	5043CX22K00J92U
A1R471	315-0223-00			RES, FXD, FILM:22K OHM, 5%, 0.25M	19701	5043CX22K00J92U
A1R473	315-0471-00			RES, FXD, FILM:470 OHM, 5%, 0.25M	57668	NTR25J-E470E
A1R476	315-0750-00			RES, FXD, FILM:75 OHM, 5%, 0.25M	57668	NTR25J-E75E0
A1R477	315-0472-00			RES, FXD, FILM:4.7K OHM, 5%, 0.25M	57668	NTR25J-ED4K7
A1R478	321-0193-03			RES, FXD, FILM:1K OHM, 0.25%, 0.125M, TC=T2	07716	CEAC10000C
A1R479	315-0102-00			RES, FXD, FILM:1K OHM, 5%, 0.25M	57668	NTR25JE01K0
A1R480	321-0375-00			RES, FXD, FILM:78.7K OHM, 1%, 0.125M, TC=T0	07716	CEAD78701F
A1R481	321-0347-00			RES, FXD, FILM:40.2K OHM, 1%, 0.125M, TC=T0	91637	CMF55116640201F
A1R482	315-0471-00			RES, FXD, FILM:470 OHM, 5%, 0.25M	57668	NTR25J-E470E
A1R483	321-0347-00			RES, FXD, FILM:40.2K OHM, 1%, 0.125M, TC=T0	91637	CMF55116640201F
A1R484	315-0202-00			RES, FXD, FILM:2K OHM, 5%, 0.25M	57668	NTR25J-E 2K
A1R485	315-0202-00			RES, FXD, FILM:2K OHM, 5%, 0.25M	57668	NTR25J-E 2K
A1R486	321-0347-00			RES, FXD, FILM:40.2K OHM, 1%, 0.125M, TC=T0	91637	CMF55116640201F
A1R487	321-0130-03			RES, FXD, FILM:221 OHM, 0.25%, 0.125M, TC=T2 MI	91637	MFF18160221R0C
A1R488	321-1216-03			RES, FXD, FILM:1.76K OHM, 0.25%, 0.125M, TC=T2	24546	NC55C1761C
A1R489	321-1216-03			RES, FXD, FILM:1.76K OHM, 0.25%, 0.125M, TC=T2	24546	NC55C1761C
A1R490	321-0375-00			RES, FXD, FILM:78.7K OHM, 1%, 0.125M, TC=T0	07716	CEAD78701F

2445A Replaceable Electrical Parts
2445A/2455A Service

Component No.	Tektronix Part No.	Serial/Assembly No. Effective Dscont	Name & Description	Mfr. Code	Mfr. Part No.
A1R491	315-0102-00		RES, FXD, FILM:1K OHM, 5%, 0.25M	57668	NTR25JE01K0
A1R492	321-0193-03		RES, FXD, FILM:1K OHM, 0.25%, 0.125M, TC=T2	07716	CEAC10000C
A1R493	315-0472-00		RES, FXD, FILM:4.7K OHM, 5%, 0.25M	57668	NTR25J-E04K7
A1R494	315-0201-00		RES, FXD, FILM:200 OHM, 5%, 0.25M	57668	NTR25J-E200E
A1R495	315-0750-00		RES, FXD, FILM:75 OHM, 5%, 0.25M	57668	NTR25J-E75E0
A1R496	315-0113-00		RES, FXD, FILM:11K OHM, 5%, 0.25M	19701	5043CX11K00J
A1R497	315-0821-00		RES, FXD, FILM:820 OHM, 5%, 0.25M	19701	5043CX820R0J
A1R498	315-0821-00		RES, FXD, FILM:820 OHM, 5%, 0.25M	19701	5043CX820R0J
A1R500	315-0331-00		RES, FXD, FILM:330 OHM, 5%, 0.25M	57668	NTR25J-E330E
A1R501	315-0101-00		RES, FXD, FILM:100 OHM, 5%, 0.25M	57668	NTR25J-E 100E
A1R502	315-0622-00		RES, FXD, FILM:6.2K OHM, 5%, 0.25M	19701	5043CX6K200J
A1R503	315-0103-00		RES, FXD, FILM:10K OHM, 5%, 0.25M	19701	5043CX10K00J
A1R504	315-0103-00		RES, FXD, FILM:10K OHM, 5%, 0.25M	19701	5043CX10K00J
A1R511	321-0320-00		RES, FXD, FILM:21.0K OHM, 1%, 0.125M, TC=T0	19701	5033ED21K00F
A1R512	321-0293-00		RES, FXD, FILM:11.0K OHM, 1%, 0.125M, TC=T0	07716	CEA011001F
A1R513	315-0470-00		RES, FXD, FILM:47 OHM, 5%, 0.25M	57668	NTR25J-E47E0
A1R518	315-0680-00		RES, FXD, FILM:68 OHM, 5%, 0.25M	57668	NTR25J-E68E0
A1R519	315-0621-00		RES, FXD, FILM:620 OHM, 5%, 0.25M	57668	NTR25J-E620E
A1R520	315-0393-00		RES, FXD, FILM:39K OHM, 5%, 0.25M	57668	NTR25J-E39K0
A1R521	315-0750-00		RES, FXD, FILM:75 OHM, 5%, 0.25M	57668	NTR25J-E75E0
A1R527	315-0750-00		RES, FXD, FILM:75 OHM, 5%, 0.25M	57668	NTR25J-E75E0
A1R529	315-0561-00		RES, FXD, FILM:560 OHM, 5%, 0.25M	19701	5043CX560R0J
A1R537	315-0101-00		RES, FXD, FILM:100 OHM, 5%, 0.25M	57668	NTR25J-E 100E
A1R538	315-0621-00		RES, FXD, FILM:620 OHM, 5%, 0.25M	57668	NTR25J-E620E
A1R542	315-0680-00		RES, FXD, FILM:68 OHM, 5%, 0.25M	57668	NTR25J-E68E0
A1R543	315-0621-00		RES, FXD, FILM:620 OHM, 5%, 0.25M	57668	NTR25J-E620E
A1R544	315-0393-00		RES, FXD, FILM:39K OHM, 5%, 0.25M	57668	NTR25J-E39K0
A1R545	315-0750-00		RES, FXD, FILM:75 OHM, 5%, 0.25M	57668	NTR25J-E75E0
A1R550	315-0471-00		RES, FXD, FILM:470 OHM, 5%, 0.25M	57668	NTR25J-E470E
A1R551	321-1682-07		RES, FXD, FILM:5.7K OHM, 0.1%, 0.125M, TC=T9	19701	5033RE5K701B
A1R552	321-0641-07		RES, FXD, FILM:1.8K OHM, 0.190, 0.125M, TC=T9	07716	CEAE 18000B
A1R553	315-0152-00		RES, FXD, FILM:1.5K OHM, 5%, 0.25M	57668	NTR25J-ED1K5
A1R554	315-0162-00		RES, FXD, FILM:1.6K OHM, 5%, 0.25M	19701	5043CX1K600J
A1R555	321-0294-00		RES, FXD, FILM:11.3K OHM, 1%, 0.125M, TC=T0	19701	5043ED11K30F
A1R556	321-0282-00		RES, FXD, FILM:8.45K OHM, 1%, 0.125M, TC=T0	07716	CFAD84500F
A1R557	321-0808-07		RES, FXD, FILM:300 OHM, 0.1%, 0.125M, TC=T9	24546	NE55E3000B
A1R558	321-0657-07		RES, FXD, FILM:60 OHM, 0.1%, 0.125M, TC=T9	57668	R8148ZE 60E
A1R560	315-0621-00		RES, FXD, FILM:620 OHM, 5%, 0.25M	57668	NTR25J-E620E
A1R600	315-0270-00		RES, FXD, FILM:27 OHM, 5%, 0.25M	19701	5043CX27R00J
A1R601	313-1750-00		RES, FXD, FILM:75 OHM, 5%, 0.2M	57668	TR20JE 75E
A1R602	315-0470-00		RES, FXD, FILM:47 OHM, 5%, 0.25M	57668	NTR25J-E47E0
A1R605	311-2227-00		RES, VAR, NONNM:TRMR, 100 OHM, 20%, 0.5M LINEAR	TK1450	GF06UT 100
A1R606	315-0100-00		RES, FXD, FILM:10 OHM, 5%, 0.25M	19701	5043CX10RR00J
A1R607	315-0100-00		RES, FXD, FILM:10 OHM, 5%, 0.25M	19701	5043CX10RR00J
A1R610	307-0106-00		RES, FXD, CMPSN:4.7 OHM, 5%, 0.25M	01121	CB 47G5
A1R614	315-0103-00		RES, FXD, FILM:10K OHM, 5%, 0.25M	19701	5043CX10K00J
A1R615	315-0103-00		RES, FXD, FILM:10K OHM, 5%, 0.25M	19701	5043CX10K00J
A1R617	315-0102-00		RES, FXD, FILM:1K OHM, 5%, 0.25M	57668	NTR25JE01K0
A1R618	311-2234-00		RES, VAR, NONNM:TRMR, 5K OHM, 20%, 0.5M	TK1450	GF06UT 5K
A1R619	315-0270-00		RES, FXD, FILM:27 OHM, 5%, 0.25M	19701	5043CX27R00J
A1R620	315-0472-00		RES, FXD, FILM:4.7K OHM, 5%, 0.25M	57668	NTR25J-E04K7
A1R622	321-0226-00		RES, FXD, FILM:2.21K OHM, 1%, 0.125M, TC=T0	01121	RNK2211F
A1R623	315-0101-00		RES, FXD, FILM:100 OHM, 5%, 0.25M	57668	NTR25J-E 100E
A1R624	315-0100-00		RES, FXD, FILM:10 OHM, 5%, 0.25M	19701	5043CX10RR00J
A1R637	322-3222-00		RES, FXD, FILM:2K OHM, 1%, 0.2M, TC=T0	57668	CRB20 FXE 2K00
A1R638	311-2234-00		RES, VAR, NONNM:TRMR, 5K OHM, 20%, 0.5M	TK1450	GF06UT 5K
A1R639	311-2230-00		RES, VAR, NONNM:TRMR, 500 OHM, 20%, 0.50 LINEAR	TK1450	GF06UT 500
A1R642	315-0432-00		RES, FXD, FILM:4.3K OHM, 5%, 0.25M	57668	NTR25J-E04K3
A1R643	315-0750-00		RES, FXD, FILM:75 OHM, 5%, 0.25M	57668	NTR25J-E75E0

2445A Replaceable Electrical Parts
2445A/2455A Service

Component No.	Tektronix Part No.	Serial/Assembly No. Effective Dscont	Name & Description	Mfr. Code	Mfr. Part No.
A1R644	315-0472-00		RES, FXD, FILM:4.7K OHM, 5%, 0.25M	57668	NTR25J-ED4K7
A1R645	321-0625-00		RES, FXD, FILM:5.88K OHM, 1%, 0.125M, TC=TO	91637	WFF1816658800F
A1R646	321-0252-00		RES, FXD, FILM:4.12K OHM, 1%, 0.125M, TC=TO	07716	CEAD041200F
A1R650	315-0203-00		RES, FXD, FILM:20K OHM, 5%, 0.25M	57668	NTR25J-E 20K
A1R651	315-0911-00		RES, FXD, FILM:910 OHM, 5%, 0.25M	57668	NTR25J-E910E
A1R652	315-0274-00		RES, FXD, FILM:270K OHM, 5%, 0.25M	57668	NTR25J-E270K
A1R653	315-0102-00		RES, FXD, FILM:1K OHM, 5%, 0.25M	57668	NTR25JED1K0
A1R655	315-0102-00		RES, FXD, FILM:1K OHM, 5%, 0.25M	57668	NTR25JED1K0
A1R659	321-0147-00		RES, FXD, FILM:332 OHM, 1%, 0.125M, TC=TO	07716	CEAD332R0F
A1R669	321-0995-00		RES, FXD, FILM:549K OHM, 1%, 0.125M, TC=TO	24546	NA5505493F
A1R670	315-0102-00		RES, FXD, FILM:1K OHM, 5%, 0.25M	57668	NTR25JED1K0
A1R671	315-0103-00		RES, FXD, FILM:10K OHM, 5%, 0.25M	19701	5043CX10K00J
A1R678	315-0102-00		RES, FXD, FILM:1K OHM, 5%, 0.25M	57668	NTR25JED1K0
A1R700	315-0221-00		RES, FXD, FILM:220 OHM, 5%, 0.25M	57668	NTR25J-E220E
A1R701	321-0223-00		RES, FXD, FILM:2.05K OHM, 1%, 0.125M, TC=TO	80009	321-0223-00
A1R702	321-0252-00		RES, FXD, FILM:4.12K OHM, 1%, 0.125M, TC=TO	07716	CEAD041200F
A1R707	315-0122-00		RES, FXD, FILM:1.2K OHM, 5%, 0.25M	57668	NTR25J-ED1K2
A1R708	315-0242-00		RES, FXD, FILM:2.4K OHM, 5%, 0.25M	57668	NTR25J-ED2K4
A1R709	315-0472-00		RES, FXD, FILM:4.7K OHM, 5%, 0.25M	57668	NTR25J-ED4K7
A1R710	315-0396-00		RES, FXD, FILM:39M OHM, 5%, 0.25M	01121	C83965
A1R713	315-0822-00		RES, FXD, FILM:8.2K OHM, 5%, 0.25M	19701	5043CX8K200J
A1R723	321-0245-00		RES, FXD, FILM:3.48K OHM, 1%, 0.125M, TC=TO	19701	5033ED3K48F
A1R724	321-0680-00		RES, FXD, FILM:35.3K OHM, 0.5%, 0.125M, TC=T2	19701	5033RC35K300
A1R731	315-0153-00		RES, FXD, FILM:15K OHM, 5%, 0.25M	19701	5043CX15K00J
A1R732	315-0682-00		RES, FXD, FILM:6.8K OHM, 5%, 0.25M	57668	NTR25J-ED6K8
A1R733	315-0182-00		RES, FXD, FILM:1.8K OHM, 5%, 0.25M	57668	NTR25J-E1K8
A1R734	315-0221-00		RES, FXD, FILM:220 OHM, 5%, 0.25M	57668	NTR25J-E220E
A1R735	315-0273-00		RES, FXD, FILM:27K OHM, 5%, 0.25M	57668	NTR25J-E27K0
A1R736	321-0217-00		RES, FXD, FILM:1.78K OHM, 1%, 0.125M, TC=TO	19701	5043D1K780F
A1R737	321-0263-00		RES, FXD, FILM:5.36K OHM, 1%, 0.125M, TC=TO	07716	CEAD53600F
A1R738	321-0273-00		RES, FXD, FILM:6.81K OHM, 1%, 0.125M, TC=TO	07716	CEAD68100F
A1R741	315-0272-00		RES, FXD, FILM:2.7K OHM, 5%, 0.25M	57668	NTR25J-ED2K7
A1R742	315-0151-00		RES, FXD, FILM:150 OHM, 5%, 0.25M	57668	NTR25J-E150E
A1R743	315-0102-00		RES, FXD, FILM:1K OHM, 5%, 0.25M	57668	NTR25JED1K0
A1R744	315-0750-00		RES, FXD, FILM:75 OHM, 5%, 0.25M	57668	NTR25J-E75ED
A1R745	315-0242-00		RES, FXD, FILM:2.4K OHM, 5%, 0.25M	57668	NTR25J-ED2K4
A1R746	301-0470-00		RES, FXD, FILM:47 OHM, 5%, 0.5M	19701	5053CX47R00J
A1R750	315-0271-00		RES, FXD, FILM:270 OHM, 5%, 0.25M	57668	NTR25J-E270E
A1R751	315-0622-00		RES, FXD, FILM:6.2K OHM, 5%, 0.25M	19701	5043CX6K200J
A1R752	321-0269-00		RES, FXD, FILM:6.19K OHM, 1%, 0.125M, TC=TO	07716	CEAD61900F
A1R753	321-0265-00		RES, FXD, FILM:5.62K OHM, 1%, 0.125M, TC=TO	19701	5043ED5K620F
A1R754	315-0104-00		RES, FXD, FILM:100K OHM, 5%, 0.25M	57668	NTR25J-E100K
A1R800	321-0147-00		RES, FXD, FILM:332 OHM, 1%, 0.125M, TC=TO	07716	CEAD332R0F
A1R801	311-2230-00		RES, VAR, NONWH:TRMR, 500 OHM, 20%, 0.50 LINEAR	TK1450	GF06UT 500
A1R802	313-1222-00		RES, FXD, FILM:2.2K OHM, 5%, 0.2M	57668	TR20JE 02K2
A1R803	313-1821-00		RES, FXD, FILM:820 OHM, 5%, 0.2M	57668	TR20JE 820E
A1R804	315-0151-00		RES, FXD, FILM:150 OHM, 5%, 0.25M	57668	NTR25J-E150E
A1R805	311-1242-00		RES, VAR, NONWH:TRMR, 200K OHM, 0.5M	32997	3386X-T07-204
A1R806	315-0204-00		RES, FXD, FILM:200K OHM, 5%, 0.25M	19701	5043CX200K0J
A1R809	315-0151-00		RES, FXD, FILM:150 OHM, 5%, 0.25M	57668	NTR25J-E150E
A1R811	301-0331-00		RES, FXD, FILM:330 OHM, 5%, 0.5M	19701	5053CX330R0J
A1R817	315-0221-00		RES, FXD, FILM:220 OHM, 5%, 0.25M	57668	NTR25J-E220E
A1R820	321-0337-00		RES, FXD, FILM:31.6K OHM, 1%, 0.125M, TC=TO	07716	CEAD31601F
A1R821	321-0330-00		RES, FXD, FILM:26.7K OHM, 1%, 0.125M, TC=TO	07716	CEAD26701F
A1R822	315-0271-00		RES, FXD, FILM:270 OHM, 5%, 0.25M	57668	NTR25J-E270E
A1R823	321-0193-00		RES, FXD, FILM:1K OHM, 1%, 0.125M, TC=TO	19701	5033ED1K00F
A1R849	315-0333-00		RES, FXD, FILM:33K OHM, 5%, 0.25M	57668	NTR25J-E33K0
A1R850	311-2234-00		RES, VAR, NONWH:TRMR, 5K OHM, 20%, 0.5M	TK1450	GF06UT 5K
A1R852	315-0240-00		RES, FXD, FILM:24 OHM, 5%, 0.25M	57668	NTR25J-E24ED

2445A Replaceable Electrical Parts
2445A/2455A Service

Component No.	Tektronix Part No.	Serial/Assembly No. Effective Dscont	Name & Description	Mfr. Code	Mfr. Part No.
A1R853	315-0240-00		RES,FXD,FILM:24 OHM,5%,0.25M	57668	NTR25J-E24E0
A1R855	315-0103-00		RES,FXD,FILM:10K OHM,5%,0.25M	19701	5043CX10K00J
A1R856	321-0210-00		RES,FXD,FILM:1.50K OHM,1%,0.125M,TC=TO	19701	5033ED1K50F
A1R858	321-0239-00		RES,FXD,FILM:3.01K OHM,1%,0.125M,TC=TO	19701	5043ED3K010F
A1R860	311-2234-00		RES,VAR,NONHM:TRMR,5K OHM,20%,0.5M	TK1450	GF06UT 5K
A1R901	315-0112-00		RES,FXD,FILM:1.1K OHM,5%,0.25M	19701	5043CX1K100J
A1R903	315-0472-00		RES,FXD,FILM:4.7K OHM,5%,0.25M	57668	NTR25J-E04K7
A1R904	315-0124-00		RES,FXD,FILM:120K OHM,5%,0.25M	19701	5043CX120K0J
A1R907	315-0471-00		RES,FXD,FILM:470 OHM,5%,0.25M	57668	NTR25J-E470E
A1R910	315-0396-00		RES,FXD,FILM:39M OHM,5%,0.25M	01121	C83965
A1R912	315-0822-00		RES,FXD,FILM:8.2K OHM,5%,0.25M	19701	5043CX8K200J
A1R924	321-0325-00		RES,FXD,FILM:23.7K OHM,1%,0.125M,TC=TO	07716	CEA023701F
A1R936	321-0225-00		RES,FXD,FILM:2.15K OHM,1%,0.125M,TC=TO	19701	5033ED2K15F
A1R937	321-0268-00		RES,FXD,FILM:6.04K OHM,1%,0.125M,TC=TO	19701	5043ED6K040F
A1R939	315-0332-00		RES,FXD,FILM:3.3K OHM,5%,0.25M	57668	NTR25J-E03K3
A1R940	315-0101-00		RES,FXD,FILM:100 OHM,5%,0.25M	57668	NTR25J-E 100E
A1R941	315-0561-00		RES,FXD,FILM:560 OHM,5%,0.25M	19701	5043CX560R0J
A1R942	321-0256-00		RES,FXD,FILM:4.53K OHM,1%,0.125M,TC=T9	19701	5033ED4K530F
A1R943	315-0121-00		RES,FXD,FILM:120 OHM,5%,0.25M	19701	5043CX120R0J
A1R944	317-0302-00		RES,FXD,CMPSM:3K OHM,5%,0.125M	01121	BB3025
A1R945	315-0621-00		RES,FXD,FILM:620 OHM,5%,0.25M	57668	NTR25J-E620E
A1R947	321-0117-00		RES,FXD,FILM:162 OHM,1%,0.125M,TC=TO	07716	CEAD162R0F
A1R950	301-0470-00		RES,FXD,FILM:47 OHM,5%,0.5M	19701	5053CX47R00J
A1R951	308-0555-00		RES,FXD,MM:5 OHM,5%,3M	00213	12005-5.0-5
A1R952	315-0750-00		RES,FXD,FILM:75 OHM,5%,0.25M	57668	NTR25J-E75E0
A1R956	315-0302-00		RES,FXD,FILM:3K OHM,5%,0.25M	57668	NTR25J-E03K0
A1R957	321-0291-00		RES,FXD,FILM:10.5K OHM,1%,0.125M,TC=TO	80009	321-0291-00
A1R972	315-0510-00		RES,FXD,FILM:51 OHM,5%,0.25M	19701	5043CX51R00J
A1R973	315-0513-00		RES,FXD,FILM:51K OHM,5%,0.25M	57668	NTR25J-E51K0
A1R981	315-0101-00		RES,FXD,FILM:100 OHM,5%,0.25M	57668	NTR25J-E 100E
A1R982	321-0103-00		RES,FXD,FILM:115 OHM,1%,0.125M,TC=TO	01121	RNK1150F
A1R983	315-0101-00		RES,FXD,FILM:100 OHM,5%,0.25M	57668	NTR25J-E 100E
A1R984	315-0101-00		RES,FXD,FILM:100 OHM,5%,0.25M	57668	NTR25J-E 100E
A1R995	315-0512-00		RES,FXD,FILM:5.1K OHM,5%,0.25M	57668	NTR25J-E05K1
A1S615	260-1421-00		SWITCH,PUSH:1 BTN,2 POLE,INSTRUMENT ID	59821	ORDER BY DESCR
A1U100	153-2235-01		MICROCKT,LINER:MTCHD PR,L NOISE VRT PREAMP (MATCHED WITH A1U200)	80009	153-2235-01
A1U110	156-1245-00		MICROCKT,LINER:7 XSTR,NPN,SI,HV/HIGH CUR	01295	ULN2003AN-P3
A1U120	156-1245-00		MICROCKT,LINER:7 XSTR,NPN,SI,HV/HIGH CUR	01295	ULN2003AN-P3
A1U130	156-1245-00		MICROCKT,LINER:7 XSTR,NPN,SI,HV/HIGH CUR	01295	ULN2003AN-P3
A1U140	156-0651-02		MICROCKT,DGTL:8-BIT PRL-OUT SER SHF RGTR	01295	SN74LS164NP3
A1U150	156-0651-02		MICROCKT,DGTL:8-BIT PRL-OUT SER SHF RGTR	01295	SN74LS164NP3
A1U160	156-1200-01		MICROCKT,LINER:OPERATIONAL AMPL,QUAO BIFET	80009	156-1200-01
A1U165	156-2854-00		MICROCKT,LINER:CMOS,OP AMPL QUAD	80009	156-2854-00
A1U170	156-0513-03		MICROCKT,LINER:CMOS,B CHAN ANALOG MUX	04713	MC14051BCL
A1U180	156-1191-01		MICROCKT,LINER:DUAL BI-FET OP-AMP,8 DIP	80009	156-1191-01
A1U200	153-2235-01		MICROCKT,LINER:MTCHD PR,L NOISE VRT PREAMP (MATCHED WITH A1U100)	80009	153-2235-01
A1U300	155-0238-00		MICROCKT,LINER:TRIGGER PREAMP	80009	155-0238-00
A1U350	156-1191-01		MICROCKT,LINER:DUAL BI-FET OP-AMP,8 OIP	80009	156-1191-01
A1U400	155-0236-00		MICROCKT,LINER:VERTICAL CHANNEL SWITCH	80009	155-0236-00
A1U450	156-0158-07		MICROCKT,LINER:DUAL OPNL AMPL,SCREENED	01295	MC1458JG4
A1U475	156-0048-00		MICROCKT,LINER:5 XSTR ARRAY	02735	CA3046
A1U485	156-0048-00		MICROCKT,LINER:5 XSTR ARRAY	02735	CA3046
A1U500	155-0239-02		MICROCKT,LINER:TRIGGER	80009	155-0239-02
A1U550	156-0048-00		MICROCKT,LINER:5 XSTR ARRAY	02735	CA3046
A1U600	155-0237-02		MICROCKT,LINER:VERTICAL OUTPUT,H843	80009	155-0237-02
A1U650	155-0244-01		MICROCKT,DGTL:SYSTEM LOGIC INTERFACE	31471	M 217
A1U700	155-0240-00		MICROCKT,LINER:SWEEP	80009	155-0240-00

2445A Replaceable Electrical Parts
2445A/2455A Service

Component No.	Tektronix Part No.	Serial/Assembly No. Effective Dscont	Name & Description	Mfr. Code	Mfr. Part No.
A1U735	156-0048-00		MICROCKT, LINEAR:5 XSTR ARRAY	02735	CA3046
A1U800	155-0241-02		MICROCKT, DGTL:HORIZONTAL AMP SYS	80009	155-0241-02
A1U850	156-0515-02		MICROCKT, DGTL:TRIPLE 3-CHAN MUX, SEL	80009	156-0515-02
A1U860	156-0515-02		MICROCKT, DGTL:TRIPLE 3-CHAN MUX, SEL	80009	156-0515 02
A1U900	155-0240-00		MICROCKT, LINEAR:SWEEP	80009	155-0240-00
A1U910	156-1191-01		MICROCKT, LINEAR:DUAL BI-FET OP-AMP, 8 DIP	80009	156-1191-01
A1U950	155-0242-01		MICROCKT, LINEAR:Z AXIS AUTOFOCUS	80009	155-0242-01
A1U975	156-0382-02		MICROCKT, DGTL:QUAD 2 INP NAND GATE BURN	18324	N74LS00NB
A1U980	156-1724-00		MICROCKT, DGTL:QUAD 2 INPUT OR GATE	04713	MC74F32ND
A1VR112	152-0166-00		SEMICONV DVC, DI:ZEN, SI, 6.2V, 5%, 0.4M, 00-7	04713	SZ11738RL
A1VR125	152-0166-00		SEMICONV DVC, DI:ZEN, SI, 6.2V, 5%, 0.4M, 00-7	04713	SZ11738RL
A1VR225	152-0166-00		SEMICONV DVC, DI:ZEN, SI, 6.2V, 5%, 0.4M, 00-7	04713	SZ11738RL
A1VR550	152-0195-00		SEMICONV DVC, DI:ZEN, SI, 5.1V, 5%, 0.4M, 00-7	04713	SZ11755RL
A1M101	131-0566-00		BUS, COND:DUMMY RES, 0.094 00 X 0.225L	24546	OMA 07
A1M102	131-0566-00		BUS, COND:DUMMY RES, 0.094 00 X 0.225L	24546	OMA 07
A1M103	131-0566-00		BUS, COND:DUMMY RES, 0.094 00 X 0.225L	24546	OMA 07
A1M104	131-0566-00		BUS, COND:DUMMY RES, 0.094 00 X 0.225L	24546	OMA 07
A1M105	131-0566-00		BUS, COND:DUMMY RES, 0.094 00 X 0.225L	24546	OMA 07
A1M106	195-6500-02		LEAD, ELECTRICAL:22 ANG, 1.75 L, 9-N	TK1544	195-6500-02
A1M107	195-6500-02		LEAD, ELECTRICAL:22 ANG, 1.75 L, 9-N	TK1544	195-6500-02
A1M108	195-6500-02		LEAD, ELECTRICAL:22 ANG, 1.75 L, 9-N	TK1544	195-6500-02
A1M109	131-0566-00		BUS, COND:DUMMY RES, 0.094 00 X 0.225L	24546	OMA 07
A1M120	131-0566-00		BUS, COND:DUMMY RES, 0.094 00 X 0.225L	24546	OMA 07
A1M121	175-4594-01		CA ASSY, SP, ELEC:6, 22 ANG, 5.25 L	80009	175-4594-01
A1M122	175-4598-00		CA ASSY, SP, ELEC:8, 26 ANG, 7.0 L, RIBBON	80009	175-4598-00
A1M141	174-0385-00		CA ASSY, SP, ELEC:5, 22 ANG, 2.6 L, 9-N	80009	174-0385-00
A1M180	131-0566-00		BUS, COND:DUMMY RES, 0.094 00 X 0.225L	24546	OMA 07
A1M280	131-0566-00		BUS, COND:DUMMY RES, 0.094 00 X 0.225L	24546	OMA 07
A1M918	195-3991-01		LEAD, ELECTRICAL:22 ANG, 3.5 L, 0-N	80009	195-3991-01
A1M919	195-3991-01		LEAD, ELECTRICAL:22 ANG, 3.5 L, 0-N	80009	195-3991-01
A1X100	136-0763-00		SKT, PL-IN ELEX:26 LINE CONT IMPD HYBRID	00779	ORDER BY DESC
A1X119	136-0728-00		SKT, PL-IN ELEX:MICROCKT, 14 CONTACT	09922	01LB14P-108
A1X191	136-0263-07		SOCKET, PIN TERM:U/M 0.025 SQ PIN (QUANTITY OF 16)	22526	ORDER BY DESC
A1X200	136-0763-00		SKT, PL-IN ELEX:26 LINE CONT IMPD HYBRID	00779	ORDER BY DESC
A1X300	136-0764-00		SKT, PL-IN ELEX:48 LINE CONT IMPD HYBRID	00779	ORDER BY DESC
A1X400	136-0763-00		SKT, PL-IN ELEX:26 LINE CONT IMPD HYBRID	00779	ORDER BY DESC
A1X500	136-0764-00		SKT, PL-IN ELEX:48 LINE CONT IMPD HYBRID	00779	ORDER BY DESC
A1X600	136-0764-00		SKT, PL-IN ELEX:48 LINE CONT IMPD HYBRID	00779	ORDER BY DESC
A1X650	136-0757-00		SKT, PL-IN ELEX:MICROCIRCUIT, 40 DIP	09922	01LB40P-108
A1X700	136-0764-00		SKT, PL-IN ELEX:48 LINE CONT IMPD HYBRID	00779	ORDER BY DESC
A1X900	136-0764-00		SKT, PL-IN ELEX:48 LINE CONT IMPD HYBRID	00779	ORDER BY DESC
A1X950	136-0764-00		SKT, PL-IN ELEX:48 LINE CONT IMPD HYBRID	00779	ORDER BY DESC
A2	672-1037-11		CIRCUIT BD ASSY:LV PMR SPLY MODULE	80009	672-1037-11
A2A1	-----		CIRCUIT BD ASSY:REGULATOR (AVAILABLE AT THE 672-1037-XX LEVEL ONLY)		
A2A1C1016	285-1222-00		CAP, FXD, PLASTIC:0.068UF, 20%, 250V	55112	158/.068/M/250/H
A2A1C1018	285-1222-00		CAP, FXD, PLASTIC:0.068UF, 20%, 250V	55112	158/.068/M/250/H
A2A1C1208	281-0775-00		CAP, FXD, CER DI:0.1UF, 20%, 50V	04222	WA205E104MAA
A2A1C1220	290-0939-00		CAP, FXD, ELCTLT:10UF, +100-10%, 100V	56289	6720106H100CG2C
A2A1C1222	281-0783-00		CAP, FXD, CER DI:0.1 UF 20%, 100V	04222	WA401C104MAA
A2A1C1226	281-0791-00		CAP, FXD, CER DI:270PF, 10%, 100V	04222	WA101C271KAA
A2A1C1240	290-0939-00		CAP, FXD, ELCTLT:10UF, +100-10%, 100V	56289	6720106H100CG2C
A2A1C1245	281-0783-00		CAP, FXD, CER DI:0.1 UF 20%, 100V	04222	WA401C104MAA
A2A1C1246	281-0791-00		CAP, FXD, CER DI:270PF, 10%, 100V	04222	WA101C271KAA
A2A1C1260	290-0942-00		CAP, FXD, ELCTLT:100UF, +100-10%, 25V	55680	UPA1E101MAH

2445A Replaceable Electrical Parts
2445A/2455A Service

Component No.	Tektronix Part No.	Serial/Assembly No. Effective Dscont	Name & Description	Mfr. Code	Mfr. Part No.
A2A1C1261	281-0773-00		CAP,FXD,CER DI:0.01UF,10%,100V	04222	MA201C103KAA
A2A1C1270	281-0791-00		CAP,FXD,CER DI:270PF,10%,100V	04222	MA101C271KAA
A2A1C1272	281-0774-00		CAP,FXD,CER DI:0.022MFD,20%,100V	04222	MA201E223MAA
A2A1C1280	290-0942-00		CAP,FXD,ELCTLT:100UF,+100-10%,25V	55680	UPA1E101MAH
A2A1C1290	281-0775-00		CAP,FXD,CER DI:0.1UF,20%,50V	04222	MA205E104MAA
A2A1C1291	290-0778-00		CAP,FXD,ELCTLT:1UF,+50 -10%,50V,NPLZD	54473	ECE-AS0N1
A2A1C1300	290-0942-00		CAP,FXD,ELCTLT:100UF,+100-10%,25V	55680	UPA1E101MAH
A2A1C1330	290-0942-00		CAP,FXD,ELCTLT:100UF,+100-10%,25V	55680	UPA1E101MAH
A2A1C1331	281-0775-00		CAP,FXD,CER DI:0.1UF,20%,50V	04222	MA205E104MAA
A2A1C1350	290-0942-00		CAP,FXD,ELCTLT:100UF,+100-10%,25V	55680	UPA1E101MAH
A2A1C1357	281-0773-00		CAP,FXD,CER DI:0.01UF,10%,100V	04222	MA201C103KAA
A2A1C1374	281-0791-00		CAP,FXD,CER DI:270PF,10%,100V	04222	MA101C271KAA
A2A1C1400	290-0943-01		CAP,FXD,ELCTLT:47UF,20%,25V	55680	ULB1E470MPAANA1T
A2A1C1402	290-0943-01		CAP,FXD,ELCTLT:47UF,20%,25V	55680	ULB1E470MPAANA1T
A2A1C1974	290-0778-00		CAP,FXD,ELCTLT:1UF,+50 -10%,50V,NPLZD	54473	ECE-AS0N1
A2A1CR1011	152-0750-00		SEMICOND DVC,DI:RECT BRDG,600V,3A,FAST RCVY	05828	RK8PC606-12
A2A1CR1220	152-0066-00		SEMICOND DVC,DI:RECT,SI,400V,1A,DO-41	05828	GP10G-020
A2A1CR1221	152-0066-00		SEMICOND DVC,DI:RECT,SI,400V,1A,DO-41	05828	GP10G-020
A2A1CR1241	152-0066-00		SEMICOND DVC,DI:RECT,SI,400V,1A,DO-41	05828	GP10G-020
A2A1CR1242	152-0066-00		SEMICOND DVC,DI:RECT,SI,400V,1A,DO-41	05828	GP10G-020
A2A1CR1243	152-0066-00		SEMICOND DVC,DI:RECT,SI,400V,1A,DO-41	05828	GP10G-020
A2A1CR1244	152-0066-00		SEMICOND DVC,DI:RECT,SI,400V,1A,DO-41	05828	GP10G-020
A2A1CR1260	152-0066-00		SEMICOND DVC,DI:RECT,SI,400V,1A,DO-41	05828	GP10G-020
A2A1CR1261	152-0066-00		SEMICOND DVC,DI:RECT,SI,400V,1A,DO-41	05828	GP10G-020
A2A1CR1262	152-0141-02		SEMICOND DVC,DI:SM,SI,30V,150MA,30V,DO-35	03508	DA2527 (1N4152)
A2A1CR1263	152-0141-02		SEMICOND DVC,DI:SM,SI,30V,150MA,30V,DO-35	03508	DA2527 (1N4152)
A2A1CR1264	152-0141-02		SEMICOND DVC,DI:SM,SI,30V,150MA,30V,DO-35	03508	DA2527 (1N4152)
A2A1CR1281	152-0141-02		SEMICOND DVC,DI:SM,SI,30V,150MA,30V,DO-35	03508	DA2527 (1N4152)
A2A1CR1282	152-0141-02		SEMICOND DVC,DI:SM,SI,30V,150MA,30V,DO-35	03508	DA2527 (1N4152)
A2A1CR1283	152-0066-00		SEMICOND DVC,DI:RECT,SI,400V,1A,DO-41	05828	GP10G-020
A2A1CR1300	152-0141-02		SEMICOND DVC,DI:SM,SI,30V,150MA,30V,DO-35	03508	DA2527 (1N4152)
A2A1CR1301	152-0141-02		SEMICOND DVC,DI:SM,SI,30V,150MA,30V,DO-35	03508	DA2527 (1N4152)
A2A1CR1302	152-0141-02		SEMICOND DVC,DI:SM,SI,30V,150MA,30V,DO-35	03508	DA2527 (1N4152)
A2A1CR1303	152-0066-00		SEMICOND DVC,DI:RECT,SI,400V,1A,DO-41	05828	GP10G-020
A2A1CR1330	152-0066-00		SEMICOND DVC,DI:RECT,SI,400V,1A,DO-41	05828	GP10G-020
A2A1CR1331	152-0066-00		SEMICOND DVC,DI:RECT,SI,400V,1A,DO-41	05828	GP10G-020
A2A1CR1332	152-0066-00		SEMICOND DVC,DI:RECT,SI,400V,1A,DO-41	05828	GP10G-020
A2A1CR1334	152-0066-00		SEMICOND DVC,DI:RECT,SI,400V,1A,DO-41	05828	GP10G-020
A2A1CR1351	152-0066-00		SEMICOND DVC,DI:RECT,SI,400V,1A,DO-41	05828	GP10G-020
A2A1CR1376	152-0141-02		SEMICOND DVC,DI:SM,SI,30V,150MA,30V,DO-35	03508	DA2527 (1N4152)
A2A1E1001	119-0181-00		ARSR,ELEC SURGE:230,GAS FILLED	25088	B1-A230
A2A1E1002	119-0181-00		ARSR,ELEC SURGE:230,GAS FILLED	25088	B1-A230
A2A1F1330	159-0185-00		FUSE,CARTRIDGE:5.2 X 20MM,0.75A,125V	TK0946	TSC-750MA
A2A1J121	131-0608-00		TERMINAL,PIN:0.365 L X 0.025 BRZ GLD PL (QUANTITY OF 6)	22526	48283-036
A2A1J122	131-0608-00		TERMINAL,PIN:0.365 L X 0.025 BRZ GLD PL (QUANTITY OF 7)	22526	48283-036
A2A1J201	131-0608-00		TERMINAL,PIN:0.365 L X 0.025 BRZ GLD PL (QUANTITY OF 4)	22526	48283-036
A2A1J202	131-0608-00		TERMINAL,PIN:0.365 L X 0.025 BRZ GLD PL (QUANTITY OF 4)	22526	48283-036
A2A1J203	131-2925-00		CONN,RCPT,ELEC:CKT BD,1 X 6,0.2 SPACING	27264	10-10-1064
A2A1J204	131-1048-00		TERM,QIK DISC.:CKT BD MT,0.11 X 0.02 BL	00779	61134-1
A2A1J205	131-1048-00		TERM,QIK DISC.:CKT BD MT,0.11 X 0.02 BL	00779	61134-1
A2A1J206	131-1048-00		TERM,QIK DISC.:CKT BD MT,0.11 X 0.02 BL	00779	61134-1
A2A1J207	131-1048-00		TERM,QIK DISC.:CKT BD MT,0.11 X 0.02 BL	00779	61134-1
A2A1L1011	108-0473-00		COIL,RF:FIXED,174UH	TK2042	ORDER BY DESCR
A2A1L1012	108-0473-00		COIL,RF:FIXED,174UH	TK2042	ORDER BY DESCR
A2A1L1402	108-0443-00		COIL,RF:FIXED,23.5UH	80009	108-0443-00

2445A Replaceable Electrical Parts
2445A/2455A Service

Component No.	Tektronix Part No.	Serial/Assembly No.		Name & Description	Mfr. Code	Mfr. Part No.
		Effective	Discont			
A2A1Q1220	151-0497-00			TRANSISTOR:NPN,SI,T0-220	04713	SJE1985
A2A1Q1221	151-0347-00			TRANSISTOR:NPN,SI,T0-92	04713	SP57951
A2A1Q1222	151-0347-00			TRANSISTOR:NPN,SI,T0-92	04713	SP57951
A2A1Q1223	151-0347-02			TRANSISTOR:NPN,SI,T0-92	56289	CT7916(AMMOPACK)
A2A1Q1240	151-0464-00			TRANSISTOR:NPN,SI,T0-220	04713	SJE412
A2A1Q1241	151-0347-00			TRANSISTOR:NPN,SI,T0-92	04713	SP57951
A2A1Q1243	151-0347-02			TRANSISTOR:NPN,SI,T0-92	56289	CT7916(AMMOPACK)
A2A1Q1245	151-0347-00			TRANSISTOR:NPN,SI,T0-92	04713	SP57951
A2A1Q1280	151-0476-00			TRANSISTOR:NPN,SI,T0-220AB	02735	68430
A2A1Q1281	151-0347-02			TRANSISTOR:NPN,SI,T0-92	56289	CT7916(AMMOPACK)
A2A1Q1300	151-0482-00			TRANSISTOR:PMP,SI,T0-220	04713	SJE1977
A2A1Q1301	151-0342-00			TRANSISTOR:PMP,SI,T0-92	07263	5035928
A2A1Q1351	151-0429-00			TRANSISTOR:PMP,SI,T0-126	04713	SJE957
A2A1Q1354	151-0342-00			TRANSISTOR:PMP,SI,T0-92	07263	5035928
A2A1Q1370	151-0341-01			TRANSISTOR:PMP,SI,T0-92	04713	TO BE ASSIGNED
A2A1Q1376	151-0341-01			TRANSISTOR:PMP,SI,T0-92	04713	TO BE ASSIGNED
A2A1R1010	301-0150-00			RES,FXD,FILM:15 OHM,5%,0.5M	19701	5053CX15R00J
A2A1R1011	315-0560-00			RES,FXD,FILM:56 OHM,5%,0.25M	57668	NTR25J-E56ED
A2A1R1012	315-0560-00			RES,FXD,FILM:56 OHM,5%,0.25M	57668	NTR25J-E56ED
A2A1R1013	315-0683-00			RES,FXD,FILM:68K OHM,5%,0.25M	57668	NTR25J-E68K0
A2A1R1014	315-0363-00	8010100	8010105	RES,FXD,FILM:36K OHM,5%,0.25M	57668	NTR25J-E36K0
A2A1R1014	313-1363-00	8010106		RES,FXD,FILM:36K OHM,5%,0.2M	57668	TR20JE 36K
A2A1R1015	315-0363-00	8010100	8010105	RES,FXD,FILM:36K OHM,5%,0.25M	57668	NTR25J-E36K0
A2A1R1015	313-1363-00	8010106		RES,FXD,FILM:36K OHM,5%,0.2M	57668	TR20JE 36K
A2A1R1016	301-0680-00			RES,FXD,FILM:68 OHM,5%,0.5M	19701	5053CX68R00J
A2A1R1017	315-0474-00	8010100	8010105	RES,FXD,FILM:470K OHM,5%,0.25M	19701	5043CX470K0J92U
A2A1R1017	313-1474-00	8010106		RES,FXD,FILM:470K OHM,5%,0.2M	80009	313-1474-00
A2A1R1018	301-0300-00			RES,FXD,FILM:30 OHM,5%,0.5M	19701	5053CX30R00J
A2A1R1019	301-0150-00			RES,FXD,FILM:15 OHM,5%,0.5M	19701	5053CX15R00J
A2A1R1204	315-0103-00	8010100	8010105	RES,FXD,FILM:10K OHM,5%,0.25M	19701	5043CX10K00J
A2A1R1204	313-1103-00	8010106		RES,FXD,FILM:10K OHM,5%,0.2M	57668	TR20JE10K0
A2A1R1208	315-0201-00	8010100	8010105	RES,FXD,FILM:200 OHM,5%,0.25M	57668	NTR25J-E200E
A2A1R1208	313-1201-00	8010106		RES,FXD,FILM:200 OHM,5%,0.2M	57668	TR20JE200E
A2A1R1212	315-0393-00	8010100	8010105	RES,FXD,FILM:39K OHM,5%,0.25M	57668	NTR25J-E39K0
A2A1R1212	313-1393-00	8010106		RES,FXD,FILM:39K OHM,5%,0.2M	57668	TR20JE 39K
A2A1R1220	304-0822-00			RES,FXD,CMPSN:8.2K OHM,10%,1M	01121	G88221
A2A1R1221	315-0100-02			RES,FXD,CMPSN:10 OHM,5%,0.25M	01121	CB1005
A2A1R1222	315-0102-00	8010100	8010105	RES,FXD,FILM:1K OHM,5%,0.25M	57668	NTR25JE01K0
A2A1R1222	313-1102-00	8010106		RES,FXD,FILM:1K OHM,5%,0.2M	57668	TR20JE01K0
A2A1R1223	315-0823-00	8010100	8010105	RES,FXD,FILM:82K OHM,5%,0.25M	57668	NTR25J-E82K
A2A1R1223	313-1823-00	8010106		RES,FXD,FILM:82K OHM,5%,0.2M	57668	TR20JE 82K
A2A1R1226	315-0472-00	8010100	8010105	RES,FXD,FILM:4.7K OHM,5%,0.25M	57668	NTR25J-ED4K7
A2A1R1226	313-1472-00	8010106		RES,FXD,FILM:4.7K OHM,5%,0.2M	57668	TR20JE 04K7
A2A1R1227	321-0634-00			RES,FXD,FILM:84.65K OHM,0.25%,0.125M,TC=T2	19701	5093RC84K65C
A2A1R1228	321-0293-03			RES,FXD,FILM:11.0K OHM,0.25%,0.125M,TC=T2	24546	NC55C1102C
A2A1R1229	315-0683-00	8010100	8010105	RES,FXD,FILM:68K OHM,5%,0.25M	57668	NTR25J-E68K0
A2A1R1229	313-1683-00	8010106		RES,FXD,FILM:68K OHM,5%,0.2M	57668	TR20JE 68K
A2A1R1240	303-0202-00			RES,FXD,CMPSN:2K OHM,5%,1M	01121	G8 2025
A2A1R1241	307-0105-00			RES,FXD,CMPSN:3.9 OHM,5%,0.25M	01121	CB 39G5
A2A1R1242	315-0152-00	8010100	8010105	RES,FXD,FILM:1.5K OHM,5%,0.25M	57668	NTR25J-ED1K5
A2A1R1242	313-1152-00	8010106		RES,FXD,FILM:1.5K OHM,5%,0.2M	57668	TR20JE01K5
A2A1R1243	315-0393-00	8010100	8010105	RES,FXD,FILM:39K OHM,5%,0.25M	57668	NTR25J-E39K0
A2A1R1243	313-1393-00	8010106		RES,FXD,FILM:39K OHM,5%,0.2M	57668	TR20JE 39K
A2A1R1244	315-0104-00	8010100	8010105	RES,FXD,FILM:100K OHM,5%,0.25M	57668	NTR25J-E100K
A2A1R1244	313-1104-00	8010106		RES,FXD,FILM:100K OHM,5%,0.2M	57668	TR20JE100K
A2A1R1246	315-0472-00	8010100	8010105	RES,FXD,FILM:4.7K OHM,5%,0.25M	57668	NTR25J-ED4K7
A2A1R1246	313-1472-00	8010106		RES,FXD,FILM:4.7K OHM,5%,0.2M	57668	TR20JE 04K7
A2A1R1247	321-0368-00			RES,FXD,FILM:66.5K OHM,1%,0.125M,TC=TO	07716	CEAD66501F
A2A1R1248	321-0319-00			RES,FXD,FILM:20.5K OHM,1%,0.125M,TC=TO	19701	5033ED20K50F

2445A Replaceable Electrical Parts
2445A/2455A Service

Component No.	Tektronix Part No.	Serial/Assembly No. Effective	Discont	Name & Description	Mfr. Code	Mfr. Part No.
A2A1R1249	315-0473-00	B010100	B010105	RES,FXD,FILM:47K OHM,5%,0.25M	57668	NTR25J-E47K0
A2A1R1249	313-1473-00	B010106		RES,FXD,FILM:47K OHM,5%,0.2M	57668	TR20JE 47K
A2A1R1261	321-0289-00			RES,FXD,FILM:10.0K OHM,1%,0.125M,TC=T0	19701	5033ED10K0F
A2A1R1262	321-0318-00			RES,FXD,FILM:20.0K OHM,1%,0.125M,TC=T0	19701	5033ED20K00F
A2A1R1264	315-0473-00	B010100	B010105	RES,FXD,FILM:47K OHM,5%,0.25M	57668	NTR25J-E47K0
A2A1R1264	313-1473-00	B010106		RES,FXD,FILM:47K OHM,5%,0.2M	57668	TR20JE 47K
A2A1R1270	315-0432-00	B010100	B010105	RES,FXD,FILM:4.3K OHM,5%,0.25M	57668	NTR25J-E04K3
A2A1R1270	313-1432-00	B010106		RES,FXD,FILM:4.3K OHM,5%,0.2M	57668	TR20JE 04K3
A2A1R1273	315-0473-00	B010100	B010105	RES,FXD,FILM:47K OHM,5%,0.25M	57668	NTR25J-E47K0
A2A1R1273	313-1473-00	B010106		RES,FXD,FILM:47K OHM,5%,0.2M	57668	TR20JE 47K
A2A1R1274	315-0683-00	B010100	B010105	RES,FXD,FILM:68K OHM,5%,0.25M	57668	NTR25J-E68K0
A2A1R1274	313-1683-00	B010106		RES,FXD,FILM:68K OHM,5%,0.2M	57668	TR20JE 68K
A2A1R1280	303-0470-00			RES,FXD,CMPSPN:47 OHM,5%,1M	01121	GB4705
A2A1R1281	308-0839-00			RES,FXD,MM:0.1 OHM,5%,1.0M	75042	BM-20-R1000J
A2A1R1282	315-0102-00	B010100	B010105	RES,FXD,FILM:1K OHM,5%,0.25M	57668	NTR25JE01K0
A2A1R1282	313-1102-00	B010106		RES,FXD,FILM:1K OHM,5%,0.2M	57668	TR20JE01K0
A2A1R1283	315-0103-00	B010100	B010105	RES,FXD,FILM:10K OHM,5%,0.25M	19701	5043CX10K00J
A2A1R1283	313-1103-00	B010106		RES,FXD,FILM:10K OHM,5%,0.2M	57668	TR20JE10K0
A2A1R1284	321-0318-00			RES,FXD,FILM:20.0K OHM,1%,0.125M,TC=T0	19701	5033ED20K00F
A2A1R1285	321-0318-00			RES,FXD,FILM:20.0K OHM,1%,0.125M,TC=T0	19701	5033ED20K00F
A2A1R1286	315-0243-00	B010100	B010105	RES,FXD,FILM:24K OHM,5%,0.25M	57668	NTR25J-E24K0
A2A1R1286	313-1243-00	B010106		RES,FXD,FILM:24K OHM,5%,0.2M	80009	313-1243-00
A2A1R1287	315-0472-00	B010100	B010105	RES,FXD,FILM:4.7K OHM,5%,0.25M	57668	NTR25J-E04K7
A2A1R1287	313-1472-00	B010106		RES,FXD,FILM:4.7K OHM,5%,0.2M	57668	TR20JE 04K7
A2A1R1291	321-0334-00			RES,FXD,FILM:29.4K OHM,1%,0.125M,TC=T0	07716	CEAD29401F
A2A1R1292	311-1138-00			RES,VAR,NONMM:TRMR,1K OHM,0.5M	32997	3386J-T07-102
A2A1R1293	321-0639-00			RES,FXD,FILM:9.6K OHM,1%,0.125M,TC=T0	19701	5043E9K600F
A2A1R1300	303-0470-00			RES,FXD,CMPSPN:47 OHM,5%,1M	01121	GB4705
A2A1R1301	308-0839-00			RES,FXD,MM:0.1 OHM,5%,1.0M	75042	BM-20-R1000J
A2A1R1302	315-0102-00	B010100	B010105	RES,FXD,FILM:1K OHM,5%,0.25M	57668	NTR25JE01K0
A2A1R1302	313-1102-00	B010106		RES,FXD,FILM:1K OHM,5%,0.2M	57668	TR20JE01K0
A2A1R1304	315-0243-00	B010100	B010105	RES,FXD,FILM:24K OHM,5%,0.25M	57668	NTR25J-E24K0
A2A1R1304	313-1243-00	B010106		RES,FXD,FILM:24K OHM,5%,0.2M	80009	313-1243-00
A2A1R1305	321-0289-06			RES,FXD,FILM:10.0K OHM,0.25%,0.125M,TC=T9	19701	5033RE10K00C
A2A1R1306	321-0318-03			RES,FXD,FILM:20.0K OHM,0.125%,0.125M,TC=T2	19701	5033RC20K00C
A2A1R1307	315-0472-00	B010100	B010105	RES,FXD,FILM:4.7K OHM,5%,0.25M	57668	NTR25J-E04K7
A2A1R1307	313-1472-00	B010106		RES,FXD,FILM:4.7K OHM,5%,0.2M	57668	TR20JE 04K7
A2A1R1309	315-0222-00	B010100	B010105	RES,FXD,FILM:2.2K OHM,5%,0.25M	57668	NTR25J-E02K2
A2A1R1309	313-1222-00	B010106		RES,FXD,FILM:2.2K OHM,5%,0.2M	57668	TR20JE 02K2
A2A1R1331	321-0685-00			RES,FXD,FILM:30K OHM,0.5%,0.125M,TC=T2	19701	5033RC30K00D
A2A1R1332	321-0318-03			RES,FXD,FILM:20.0K OHM,0.125%,0.125M,TC=T2	19701	5033RC20K00C
A2A1R1333	315-0751-00	B010100	B010105	RES,FXD,FILM:750 OHM,5%,0.25M	57668	NTR25J-E750E
A2A1R1333	313-1751-00	B010106		RES,FXD,FILM:750 OHM,5%,0.2M	57668	TR20JE 750E
A2A1R1334	315-0103-00	B010100	B010105	RES,FXD,FILM:10K OHM,5%,0.25M	19701	5043CX10K00J
A2A1R1334	313-1103-00	B010106		RES,FXD,FILM:10K OHM,5%,0.2M	57668	TR20JE10K0
A2A1R1351	315-0202-00	B010100	B010105	RES,FXD,FILM:2K OHM,5%,0.25M	57668	NTR25J-E 2K
A2A1R1351	313-1202-00	B010106		RES,FXD,FILM:2K OHM,5%,0.2M	57668	TR20JE02K0
A2A1R1352	301-0150-00			RES,FXD,FILM:15 OHM,5%,0.5M	19701	5053CX15R00J
A2A1R1353	301-0150-00			RES,FXD,FILM:15 OHM,5%,0.5M	19701	5053CX15R00J
A2A1R1354	315-0222-00	B010100	B010105	RES,FXD,FILM:2.2K OHM,5%,0.25M	57668	NTR25J-E02K2
A2A1R1354	313-1222-00	B010106		RES,FXD,FILM:2.2K OHM,5%,0.2M	57668	TR20JE 02K2
A2A1R1355	315-0682-00	B010100	B010105	RES,FXD,FILM:6.8K OHM,5%,0.25M	57668	NTR25J-E06K8
A2A1R1355	313-1682-00	B010106		RES,FXD,FILM:6.8K OHM,5%,0.2M	57668	TR20JE 06K8
A2A1R1356	315-0512-00	B010100	B010105	RES,FXD,FILM:5.1K OHM,5%,0.25M	57668	NTR25J-E05K1
A2A1R1356	313-1512-00	B010106		RES,FXD,CMPSPN:5.1K OHM,5%,0.2M	57668	TR20JE 5K1
A2A1R1357	321-0318-03			RES,FXD,FILM:20.0K OHM,0.125%,0.125M,TC=T2	19701	5033RC20K00C
A2A1R1358	321-0689-00			RES,FXD,FILM:24.9K OHM,0.5%,0.125M,TC=T0	19701	5033RD24K900
A2A1R1359	315-0682-00	B010100	B010105	RES,FXD,FILM:6.8K OHM,5%,0.25M	57668	NTR25J-E06K8
A2A1R1359	313-1682-00	B010106		RES,FXD,FILM:6.8K OHM,5%,0.2M	57668	TR20JE 06K8

2445A Replaceable Electrical Parts
2445A/2455A Service

Component No.	Tektronix Part No.	Serial/Assembly No. Effective	Discont	Name & Description	Mfr. Code	Mfr. Part No.
A2A1R1370	321-0363-00			RES,FXO,FILM:59.0K OHM,1%,0.125M,TC=T0	07716	CEAD58001F
A2A1R1372	321-0299-00			RES,FXO,FILM:12.7K OHM,1%,0.125M,TC=T0	19701	5033ED12K70F
A2A1R1374	315-0103-00	8010100	8010105	RES,FXO,FILM:10K OHM,5%,0.25M	19701	5043CX10K00J
A2A1R1374	313-1104-00	8010106		RES,FXO,FILM:100K OHM,5%,0.2M	57668	TR20JE100K
A2A1R1376	321-0318-03			RES,FXO,FILM:20.0K OHM,0.125%,0.125M,TC=T2	19701	5033RC20K00C
A2A1R1378	315-0202-00	8010100	8010105	RES,FXO,FILM:2K OHM,5%,0.25M	57668	NTR25J-E 2K
A2A1R1378	313-1202-00	8010106		RES,FXO,FILM:2K OHM,5%,0.2M	57668	TR20JE02K0
A2A1R1400	315-0101-03			RES,FXO,CMPNSN:100 OHM,5%,0.25M	01121	CB1015
A2A1R1402	315-0101-03			RES,FXO,CMPNSN:100 OHM,5%,0.25M	01121	CB1015
A2A1RT1010	307-0350-00			RES,THERMAL:7.5 OHM,10%,3.9%/DEG C	80009	307-0350-00
A2A1RT1016	307-0746-00			RES,THERMAL:5 OHM,10%,7A/DEG C	15454	SG200-S
A2A1S350	260-1849-00			SWITCH,PUSH:OPDT,4A,250VAC	31918	NE15/F2U103EE
A2A1T1229	120-1401-00			XFMR,TRIGGER:LINE,1:1 TURNS RATIO	54937	DWI 500-2044
A2A1TP201	131-0608-00			TERMINAL,PIN:0.365 L X 0.025 BRZ GLD PL	22526	48283-036
A2A1U1260	156-1161-00			MICROCKT,LINEAR:VOLTAGE REGULATOR,POS,ADJ	12969	UC317T
A2A1U1270	156-0495-02			MICROCKT,LINEAR:QUAD OPNL AMPL,SELECTED	01295	LM324J4
A2A1U1281	156-0158-07			MICROCKT,LINEAR:QUAD OPNL AMPL,SCREENED	01295	MC1458JG4
A2A1U1290	156-1173-00			MICROCKT,LINEAR:VOLTAGE REFERENCE	04713	MC1403U05
A2A1U1300	156-0495-02			MICROCKT,LINEAR:QUAD OPNL AMPL,SELECTED	01295	LM324J4
A2A1U1330	156-0872-00			MICROCKT,LINEAR:VOLTAGE REGULATOR	04713	MC7912CT
A2A1U1371	156-0495-02			MICROCKT,LINEAR:QUAD OPNL AMPL,SELECTED	01295	LM324J4
A2A1VR1293	152-0055-00			SEMICOND DVC,01:ZEN,SI,11V,5%,0.4M,00-7	14433	Z5407
A2A1M251	175-4585-00			CA ASSY,SP,ELEC:20,28 AWG,13.0 L	80009	175-4585-00
A3	-----			CIRCUIT 80 ASSY:INVERTER (AVAILABLE AT THE 672-1037-XX LEVEL ONLY)		
A3C1020	285-1192-00			CAP,FXO,PPR 01:0.0022 UF,20%,250VAC	TK0515	PME271Y510
A3C1021	290-0971-00			CAP,FXO,ELCTLT:290UF +50-10%,200V	56289	390X1314
A3C1022	290-0971-00			CAP,FXO,ELCTLT:290UF +50-10%,200V	56289	390X1314
A3C1023	281-0773-00			CAP,FXO,CER 01:0.01UF,10%,100V	04222	MA201C103KAA
A3C1025	290-0942-00			CAP,FXO,ELCTLT:100UF,+100-10%,25V	55680	UPA1E101MAH
A3C1032	281-0812-00			CAP,FXO,CER 01:1000PF,10%,100V	04222	MA101C102KAA
A3C1033	281-0772-00			CAP,FXO,CER 01:4700PF,10%,100V	04222	MA201C472KAA
A3C1034	290-0524-00			CAP,FXO,ELCTLT:4.7UF,20%,10V	05397	T368A475M010AZ
A3C1035	281-0772-00			CAP,FXO,CER 01:4700PF,10%,100V	04222	MA201C472KAA
A3C1040	281-0773-00			CAP,FXO,CER 01:0.01UF,10%,100V	04222	MA201C103KAA
A3C1048	281-0826-00			CAP,FXO,CER 01:2200PF,5%,100V	20932	401EM100A0222K
A3C1050	285-1254-00			CAP,FXO,PLASTIC:0.22UF,10%,400MVDC	56289	730P0167
A3C1051	285-1192-00			CAP,FXO,PPR 01:0.0022 UF,20%,250VAC	TK0515	PME271Y510
A3C1052	285-1196-00			CAP,FXO,PPR 01:0.01UF,20%,250V	TK0515	PME 265 MB 510
A3C1062	281-0850-00			CAP,FXO,CER 01:820PF,5%,50VDC	04222	MA101A821JAA
A3C1065	285-1190-00			CAP,FXO,MTLZD:0.056 UF,5%,250 V	05292	PMT3R ADVISE
A3C1066	290-0782-01			CAP,FXO,ELCTLT:4.7UF,20%,35VDC	55680	ULB1V4R7MPA1TD
A3C1067	281-0850-00			CAP,FXO,CER 01:820PF,5%,50VDC	04222	MA101A821JAA
A3C1071	281-0772-00			CAP,FXO,CER 01:4700PF,10%,100V	04222	MA201C472KAA
A3C1072	290-0806-00			CAP,FXO,ELCTLT:3.3UF,+75-10%,350VDC	55680	UHU2V3R3TPA
A3C1075	283-0421-00			CAP,FXO,CER 01:0.1UF,+80-20%,50V	04222	MD015C104MAA
A3C1101	290-0942-00			CAP,FXO,ELCTLT:100UF,+100-10%,25V	55680	UPA1E101MAH
A3C1102	290-0942-00			CAP,FXO,ELCTLT:100UF,+100-10%,25V	55680	UPA1E101MAH
A3C1110	290-0800-00			CAP,FXO,ELCTLT:250UF,+100-10%,20V	56289	6720257H0200M5C
A3C1111	290-0800-00			CAP,FXO,ELCTLT:250UF,+100-10%,20V	56289	6720257H0200M5C
A3C1112	290-0782-01			CAP,FXO,ELCTLT:4.7UF,20%,35VDC	55680	ULB1V4R7MPA1TD
A3C1113	290-0798-00			CAP,FXO,ELCTLT:180UF,+100-10%,40V	56289	6720187H0400M5C
A3C1114	290-0800-00			CAP,FXO,ELCTLT:250UF,+100-10%,20V	56289	6720257H0200M5C
A3C1115	290-0800-00			CAP,FXO,ELCTLT:250UF,+100-10%,20V	56289	6720257H0200M5C
A3C1116	290-0798-00			CAP,FXO,ELCTLT:180UF,+100-10%,40V	56289	6720187H0400M5C
A3C1120	290-0939-00			CAP,FXO,ELCTLT:10UF,+100-10%,100V	56289	6720106H100CG2C

2445A Replaceable Electrical Parts
2445A/2455A Service

Component No.	Tektronix Part No.	Serial/Assembly No. Effective	Discont	Name & Description	Mfr. Code	Mfr. Part No.
A3C1130	290-0939-00			CAP,FXD,ELCTLT:10UF,+100-10%,100V	56289	6720106H100CG2C
A3C1132	290-0880-00			CAP,FXD,ELCTLT:10UF,+50-10%,160V	54473	ECE-A160V10U
A3CR1022	152-0333-00			SEMICON DVC,DI:SM,SI,55V,200MA,00-35	07263	FDH-6012
A3CR1023	152-0141-02			SEMICON DVC,DI:SM,SI,30V,150MA,30V,00-35	03508	DA2527 (1N4152)
A3CR1028	152-0141-02			SEMICON DVC,DI:SM,SI,30V,150MA,30V,00-35	03508	DA2527 (1N4152)
A3CR1030	152-0141-02			SEMICON DVC,DI:SM,SI,30V,150MA,30V,00-35	03508	DA2527 (1N4152)
A3CR1034	152-0141-02			SEMICON DVC,DI:SM,SI,30V,150MA,30V,00-35	03508	DA2527 (1N4152)
A3CR1035	152-0141-02			SEMICON DVC,DI:SM,SI,30V,150MA,30V,00-35	03508	DA2527 (1N4152)
A3CR1040	152-0075-00			SEMICON DVC,DI:SM,GE,22V,80MM,00-7	14433	G866
A3CR1050	152-0661-00	B010100	B010327	SEMICON DVC,DI:RECT,SI,600V,3A,FAST RCYV	04713	SR3523
A3CR1050	152-0661-01	B010328		SEMICON DVC,DI:RECT,SI,600V,3A,FAST RECOV	04713	S.R.3523-1RL
A3CR1060	152-0040-00			SEMICON DVC,DI:RECT,SI,600V,1A,00-41	80009	152-0040-00
A3CR1062	152-0333-00			SEMICON DVC,DI:SM,SI,55V,200MA,00-35	07263	FDH-6012
A3CR1063	152-0333-00			SEMICON DVC,DI:SM,SI,55V,200MA,00-35	07263	FDH-6012
A3CR1064	152-0333-00			SEMICON DVC,DI:SM,SI,55V,200MA,00-35	07263	FDH-6012
A3CR1065	152-0333-00			SEMICON DVC,DI:SM,SI,55V,200MA,00-35	07263	FDH-6012
A3CR1070	152-0040-00			SEMICON DVC,DI:RECT,SI,600V,1A,00-41	80009	152-0040-00
A3CR1072	152-0066-00			SEMICON DVC,DI:RECT,SI,400V,1A,00-41	05828	GP10G-020
A3CR1101	152-0400-00			SEMICON DVC,DI:RECT,SI,400V,1A	04713	SR1977K
A3CR1102	152-0400-00			SEMICON DVC,DI:RECT,SI,400V,1A	04713	SR1977K
A3CR1103	152-0400-00			SEMICON DVC,DI:RECT,SI,400V,1A	04713	SR1977K
A3CR1104	152-0400-00			SEMICON DVC,DI:RECT,SI,400V,1A	04713	SR1977K
A3CR1105	152-0400-00			SEMICON DVC,DI:RECT,SI,400V,1A	04713	SR1977K
A3CR1106	152-0400-00			SEMICON DVC,DI:RECT,SI,400V,1A	04713	SR1977K
A3CR1110	152-0794-00			SEMICON DVC,DI:RECT,SI,10A,30V,T0-220	81483	95-4269
A3CR1113	152-0633-00	B010100	B010118	SEMICON DVC,DI:RECT,SI,30V,3A,A282	04713	1N5821
A3CR1113	152-0946-00	B010119		SEMICON DVC,DI:RECT,SI,40V,3.0A	80009	152-0946-00
A3CR1114	152-0633-00	B010100	B010118	SEMICON DVC,DI:RECT,SI,30V,3A,A282	04713	1N5821
A3CR1114	152-0946-00	B010119		SEMICON DVC,DI:RECT,SI,40V,3.0A	80009	152-0946-00
A3CR1115	152-0633-00	B010100	B010118	SEMICON DVC,DI:RECT,SI,30V,3A,A282	04713	1N5821
A3CR1115	152-0946-00	B010119		SEMICON DVC,DI:RECT,SI,40V,3.0A	80009	152-0946-00
A3CR1116	152-0633-00	B010100	B010118	SEMICON DVC,DI:RECT,SI,30V,3A,A282	04713	1N5821
A3CR1116	152-0946-00	B010119		SEMICON DVC,DI:RECT,SI,40V,3.0A	80009	152-0946-00
A3CR1121	152-0400-00			SEMICON DVC,DI:RECT,SI,400V,1A	04713	SR1977K
A3CR1122	152-0400-00			SEMICON DVC,DI:RECT,SI,400V,1A	04713	SR1977K
A3CR1123	152-0400-00			SEMICON DVC,DI:RECT,SI,400V,1A	04713	SR1977K
A3CR1124	152-0400-00			SEMICON DVC,DI:RECT,SI,400V,1A	04713	SR1977K
A3CR1131	152-0400-00			SEMICON DVC,DI:RECT,SI,400V,1A	04713	SR1977K
A3CR1132	152-0400-00			SEMICON DVC,DI:RECT,SI,400V,1A	04713	SR1977K
A3F1101	159-0255-00			FUSE,CARTRIDGE:FAST BLOW,4A,125V	80009	159-0255-00
A3F1102	159-0059-00			FUSE,WIRE LEAD:5A,125V	71400	A5
A3J301	131-0608-00			TERMINAL,PIN:0.365 L X 0.025 BRZ GLD PL (QUANTITY OF 3)	22526	48283-036
A3J302	131-0608-00			TERMINAL,PIN:0.365 L X 0.025 BRZ GLD PL (QUANTITY OF 3)	22526	48283-036
A3J303	131-2926-00			CONN,RCPT,ELEC:CKT BD,1 X 2,0.2 SPACING	27264	10-10-1024
A3L1110	108-0554-00			COIL,RF:FIXED,5UH,+/-20%	TK1345	108-0554-00
A3L1113	108-1144-00			COIL,RF:FIXED,27 UH,20%	34479	RL1284
A3L1114	108-1144-00			COIL,RF:FIXED,27 UH,20%	34479	RL1284
A3L1115	108-1144-00			COIL,RF:FIXED,27 UH,20%	34479	RL1284
A3L1116	108-1144-00			COIL,RF:FIXED,27 UH,20%	34479	RL1284
A3Q1021	151-0301-00			TRANSISTOR:PMP,SI,T0-18	04713	ST898
A3Q1022	151-0192-00			TRANSISTOR:SELECTED	04713	SPS8801
A3Q1029	151-0254-00			TRANSISTOR:DARLINGTON,NPN,SI	03508	X38L3118
A3Q1030	151-0301-00			TRANSISTOR:PMP,SI,T0-18	04713	ST898
A3Q1040	151-0302-00			TRANSISTOR:NPN,SI,T0-18	04713	ST899
A3Q1050	151-1152-00			TRANSISTOR:MOSFE,N-CHANNEL,SI,T0-220	04713	IRF820
A3Q1060	151-1152-00			TRANSISTOR:MOSFE,N-CHANNEL,SI,T0-220	04713	IRF820
A3Q1062	151-0302-00			TRANSISTOR:NPN,SI,T0-18	04713	ST899

2445A Replaceable Electrical Parts
2445A/2455A Service

Component No.	Tektronix Part No.	Serial/Assembly No. Effective	Discont	Name & Description	Mfr. Code	Mfr. Part No.
A3Q1070	151-1152-00			TRANSISTOR:MOSFE,N-CHANNEL,SI,TO-220	04713	IRF820
A3Q1110	151-0188-00			TRANSISTOR:PMP,SI,TO-92	90009	151-0188-00
A3R1018	315-0394-00	8010100	8010105	RES,FXD,FILM:390K OHM,5%,0.25M	57668	NTR25J-E390K
A3R1018	313-1394-00	8010106		RES,FXD,FILM:390K,5%,0.2M	57668	TR20JE 390K
A3R1019	315-0394-00	8010100	8010105	RES,FXD,FILM:390K OHM,5%,0.25M	57668	NTR25J-E390K
A3R1019	313-1394-00	8010106		RES,FXD,FILM:390K,5%,0.2M	57668	TR20JE 390K
A3R1020	301-0274-00			RES,FXD,FILM:270K OHM,5%,0.5M	19701	5053CX270K0J
A3R1022	315-0104-00	8010100	8010105	RES,FXD,FILM:100K OHM,5%,0.25M	57668	NTR25J-E100K
A3R1022	313-1104-00	8010106		RES,FXD,FILM:100K OHM,5%,0.2M	57668	TR20JE100K
A3R1023	315-0122-00	8010100	8010105	RES,FXD,FILM:1.2K OHM,5%,0.25M	57668	NTR25J-ED1K2
A3R1023	313-1122-00	8010106		RES,FXD,FILM:1.2K OHM,5%,0.2M	57668	TR20JED1K2
A3R1024	315-0473-00	8010100	8010105	RES,FXD,FILM:47K OHM,5%,0.25M	57668	NTR25J-E47K0
A3R1024	313-1473-00	8010106		RES,FXD,FILM:47K OHM,5%,0.2M	57668	TR20JE 47K
A3R1025	315-0302-00	8010100	8010105	RES,FXD,FILM:3K OHM,5%,0.25M	57668	NTR25J-ED3K0
A3R1025	313-1302-00	8010106		RES,FXD,FILM:3K OHM,5%,0.2M	57668	TR20JE 03K0
A3R1027	321-0431-00			RES,FXD,FILM:301K OHM,1%,0.125M,TC=TO	07716	CEAD30102F
A3R1028	321-0481-04			RES,FXD,FILM:1M OHM,0.1%,0.125M,TC=T2	91637	CMF551160100038
A3R1029	315-0152-00	8010100	8010105	RES,FXD,FILM:1.5K OHM,5%,0.25M	57668	NTR25J-ED1K5
A3R1029	313-1152-00	8010106		RES,FXD,FILM:1.5K OHM,5%,0.2M	57668	TR20JED1K5
A3R1030	315-0102-00	8010100	8010105	RES,FXD,FILM:1K OHM,5%,0.25M	57668	NTR25JED1K0
A3R1030	313-1102-00	8010106		RES,FXD,FILM:1K OHM,5%,0.2M	57668	TR20JED1K0
A3R1031	315-0334-00	8010100	8010105	RES,FXD,FILM:330K OHM,5%,0.25M	57668	NTR25J-E 330K
A3R1031	313-1334-00	8010106		RES,FXD,FILM:330K OHM,5%,0.2M	80009	313-1334-00
A3R1032	321-0335-00			RES,FXD,FILM:30.1K OHM,1%,0.125M,TC=TO	57668	R814FXE30K1
A3R1033	315-0104-00	8010100	8010105	RES,FXD,FILM:100K OHM,5%,0.25M	57668	NTR25J-E100K
A3R1033	313-1104-00	8010106		RES,FXD,FILM:100K OHM,5%,0.2M	57668	TR20JE100K
A3R1034	315-0102-00	8010100	8010105	RES,FXD,FILM:1K OHM,5%,0.25M	57668	NTR25JED1K0
A3R1034	313-1102-00	8010106		RES,FXD,FILM:1K OHM,5%,0.2M	57668	TR20JED1K0
A3R1035	315-0103-00	8010100	8010105	RES,FXD,FILM:10K OHM,5%,0.25M	19701	5043CX10K00J
A3R1035	313-1103-00	8010106		RES,FXD,FILM:10K OHM,5%,0.2M	57668	TR20JE10K0
A3R1036	315-0103-00	8010100	8010105	RES,FXD,FILM:10K OHM,5%,0.25M	19701	5043CX10K00J
A3R1036	313-1103-00	8010106		RES,FXD,FILM:10K OHM,5%,0.2M	57668	TR20JE10K0
A3R1037	315-0272-00	8010100	8010105	RES,FXD,FILM:2.7K OHM,5%,0.25M	57668	NTR25J-ED2K7
A3R1037	313-1272-00	8010106		RES,FXD,FILM:2.7K OHM,5%,0.2M	57668	TR20JE 02K7
A3R1040	315-0103-00	8010100	8010105	RES,FXD,FILM:10K OHM,5%,0.25M	19701	5043CX10K00J
A3R1040	313-1103-00	8010106		RES,FXD,FILM:10K OHM,5%,0.2M	57668	TR20JE10K0
A3R1041	315-0471-00	8010100	8010105	RES,FXD,FILM:470 OHM,5%,0.25M	57668	NTR25J-E470E
A3R1041	313-1471-00	8010106		RES,FXD,FILM:470 OHM,5%,0.2M	57668	TR20JE 470E
A3R1042	315-0102-00	8010100	8010105	RES,FXD,FILM:1K OHM,5%,0.25M	57668	NTR25JED1K0
A3R1042	313-1102-00	8010106		RES,FXD,FILM:1K OHM,5%,0.2M	57668	TR20JED1K0
A3R1044	321-0334-00			RES,FXD,FILM:29.4K OHM,1%,0.125M,TC=TO	07716	CEAD29401F
A3R1045	321-0289-00			RES,FXD,FILM:10.0K OHM,1%,0.125M,TC=TO	19701	5033ED10K0F
A3R1046	321-0422-00			RES,FXD,FILM:243K OHM,1%,0.125M,TC=TO	07716	CEAD24302F
A3R1050	308-0843-00			RES,FXD,MM:0.2 OHM,5%,1/0M	91637	RS1A-90-R2J
A3R1052	315-0470-00	8010100	8010105	RES,FXD,FILM:47 OHM,5%,0.25M	57668	NTR25J-E47ED
A3R1052	313-1470-00	8010106		RES,FXD,FILM:47 OHM,5%,0.2M	57668	TR20JE 47E
A3R1060	315-0470-00	8010100	8010105	RES,FXD,FILM:47 OHM,5%,0.25M	57668	NTR25J-E47ED
A3R1060	313-1470-00	8010106		RES,FXD,FILM:47 OHM,5%,0.2M	57668	TR20JE 47E
A3R1061	315-0202-00	8010100	8010105	RES,FXD,FILM:2K OHM,5%,0.25M	57668	NTR25J-E 2K
A3R1061	313-1202-00	8010106		RES,FXD,FILM:2K OHM,5%,0.2M	57668	TR20JED2K0
A3R1062	315-0682-00	8010100	8010105	RES,FXD,FILM:6.8K OHM,5%,0.25M	57668	NTR25J-ED6K8
A3R1062	313-1682-00	8010106		RES,FXD,FILM:6.8K OHM,5%,0.2M	57668	TR20JE 06K8
A3R1063	315-0202-00	8010100	8010105	RES,FXD,FILM:2K OHM,5%,0.25M	57668	NTR25J-E 2K
A3R1063	313-1202-00	8010106		RES,FXD,FILM:2K OHM,5%,0.2M	57668	TR20JED2K0
A3R1064	315-0202-00	8010100	8010105	RES,FXD,FILM:2K OHM,5%,0.25M	57668	NTR25J-E 2K
A3R1064	313-1202-00	8010106		RES,FXD,FILM:2K OHM,5%,0.2M	57668	TR20JED2K0
A3R1065	315-0154-00			RES,FXD,FILM:150K OHM,5%,0.25M	57668	NTR25J-E150K
A3R1066	315-0202-00	8010100	8010105	RES,FXD,FILM:2K OHM,5%,0.25M	57668	NTR25J-E 2K
A3R1066	313-1202-00	8010106		RES,FXD,FILM:2K OHM,5%,0.2M	57668	TR20JED2K0

2445A Replaceable Electrical Parts
2445A/2455A Service

Component No.	Tektronix Part No.	Serial/Assembly No. Effective	Dscont	Name & Description	Mfr. Code	Mfr. Part No.
A3R1067	315-0682-00	8010100	8010105	RES,FXD,FILM:6.8K OHM,5%,0.25M	57668	NTR25J-E06K8
A3R1067	313-1682-00	8010106		RES,FXD,FILM:6.8K OHM,5%,0.2M	57668	TR20JE 06K8
A3R1068	315-0202-00	8010100	8010105	RES,FXD,FILM:2K OHM,5%,0.25M	57668	NTR25J-E 2K
A3R1068	313-1202-00	8010106		RES,FXD,FILM:2K OHM,5%,0.2M	57668	TR20JE02K0
A3R1069	303-0363-00			RES,FXD,CMPSN:36K OHM,5%,1M	01121	G83635
A3R1070	315-0470-00	8010100	8010105	RES,FXD,FILM:47 OHM,5%,0.25M	57668	NTR25J-E47E0
A3R1070	313-1470-00	8010106		RES,FXD,FILM:47 OHM,5%,0.2M	57668	TR20JE 47E
A3R1071	315-0431-00			RES,FXD,FILM:430 OHM,5%,0.25M	19701	5043CX430R0J
A3R1072	321-0318-03			RES,FXD,FILM:20.0K OHM,0.125%,0.125M,TC=T2	19701	5033RC20K00C
A3R1075	315-0472-00	8010100	8010105	RES,FXD,FILM:4.7K OHM,5%,0.25M	57668	NTR25J-E04K7
A3R1075	313-1472-00	8010106		RES,FXD,FILM:4.7K OHM,5%,0.2M	57668	TR20JE 04K7
A3R1110	321-0219-00			RES,FXD,FILM:1.87K OHM,1%,0.125M,TC=T0	07716	CEAD18700F
A3R1111	315-0510-00			RES,FXD,FILM:51 OHM,5%,0.25M	19701	5043CX51R00J
A3R1112	321-0271-00			RES,FXD,FILM:6.49K OHM,1%,0.125M,TC=T0	07716	CEAD64900F
A3R1113	321-0271-00			RES,FXD,FILM:6.49K OHM,1%,0.125M,TC=T0	07716	CEAD64900F
A3R1114	321-0297-00			RES,FXD,FILM:12.1K OHM,1%,0.125M,TC=T0	07716	CEAD12101F
A3R1115	301-0301-00			RES,FXD,FILM:300 OHM,5%,0.5M	19701	5053CX300R0J
A3R1129	315-0474-00	8010100	8010105	RES,FXD,FILM:470K OHM,5%,0.25M	19701	5043CX470K0J92U
A3R1129	313-1472-00	8010106		RES,FXD,FILM:4.7K OHM,5%,0.2M	57668	TR20JE 04K7
A3R1130	315-0273-00	8010100	8010105	RES,FXD,FILM:27K OHM,5%,0.25M	57668	NTR25J-E27K0
A3R1130	313-1273-00	8010106		RES,FXD,FILM:27K OHM,5%,0.2M	57668	TR20JE 27K
A3RL1060	108-0329-00			COIL,RF:FIXED,2.45UH	TK2042	ORDER BY DESCR
A3RT1110	307-0124-00			RES,THERMAL:5K OHM,10%,NTC	15454	1DC502K-220-EC
A3S1020	260-0907-01			SWITCH,THRMSTC:NC,OP 97.8,CL 75.6,10A,240V	93410	430-1537
A3T1020	120-1244-00			TRANSFORMER,RF:COMMON MODE,13MH,0.5A	20462	4096
A3T1060	120-1437-00			XFMR,PMR,STPND:	02113	C1310
A3U1029	156-0885-05			CPLR,OPTOELECTR:LED,5KV,ISOLATION	09019	H11AX1139R
A3U1030	156-1627-00			MICROCKT,LINER:PULSE WIDTH MODULATED CONT	12969	UC494ACN
A3U1040	156-0885-05			CIRCUIT,SWITCHING POWER SUPPLY,SCRN	09019	H11AX1139R
A3U1064	156-0366-02			CPLR,OPTOELECTR:LED,5KV,ISOLATION MICROCKT,DGTL:DUAL D FLIP-FLOP,SCREENED	02735	CD40138FX
A3U1066	156-0328-00			MICROCKT,DGTL:DUAL MOS CLOCK DRIVER,SCRN	04713	MMH0026CP10
A3U1110	156-1161-00			MICROCKT,LINER:VOLTAGE REGULATOR,POS,ADJ	12969	UC317T
A3VR1020	152-0166-00			SEMICON DVC,DI:ZEN,SI,6.2V,5%,0.4M,00-7	04713	SZ11738RL
A3VR1062	152-0168-00			SEMICON DVC,DI:ZEN,SI,12V,5%,0.4M,00-7638	14552	T0331689
A3W1021	131-0566-00			BUS,COND:DUMMY RES,0.094 OD X 0.225L	24546	OWA 07
A3W1022	131-0566-00			BUS,COND:DUMMY RES,0.094 OD X 0.225L	24546	OWA 07
A3W1050	131-0566-00			BUS,COND:DUMMY RES,0.094 OD X 0.225L	24546	OWA 07
A3W1060	131-0566-00			BUS,COND:DUMMY RES,0.094 OD X 0.225L	24546	OWA 07
A3W1102	131-0566-00			BUS,COND:DUMMY RES,0.094 OD X 0.225L	24546	OWA 07
A3Y1050	120-1417-00			TRANSFORMER,RF:POWER HIGH FREQUENCY	54937	500-2311
A4	670-9493-00			CIRCUIT BO ASSY:READOUT	80009	670-9493-00
A4C2830	281-0909-00			CAP,FXD,CER DI:0.022UF,20%,50V	54583	MA12X7R1H223M-T
A4C2835	281-0909-00			CAP,FXD,CER DI:0.022UF,20%,50V	54583	MA12X7R1H223M-T
A4C2851	281-0909-00			CAP,FXD,CER DI:0.022UF,20%,50V	54583	MA12X7R1H223M-T
A4C2855	281-0909-00			CAP,FXD,CER DI:0.022UF,20%,50V	54583	MA12X7R1H223M-T
A4C2860	281-0909-00			CAP,FXD,CER DI:0.022UF,20%,50V	54583	MA12X7R1H223M-T
A4C2885	281-0909-00			CAP,FXD,CER DI:0.022UF,20%,50V	54583	MA12X7R1H223M-T
A4C2901	281-0909-00			CAP,FXD,CER DI:0.022UF,20%,50V	54583	MA12X7R1H223M-T
A4C2911	281-0773-00			CAP,FXD,CER DI:0.01UF,10%,100V	04222	MA201C103KAA
A4C2913	281-0909-00			CAP,FXD,CER DI:0.022UF,20%,50V	54583	MA12X7R1H223M-T
A4C2926	281-0909-00			CAP,FXD,CER DI:0.022UF,20%,50V	54583	MA12X7R1H223M-T
A4C2940	281-0909-00			CAP,FXD,CER DI:0.022UF,20%,50V	54583	MA12X7R1H223M-T
A4C2950	281-0909-00			CAP,FXD,CER DI:0.022UF,20%,50V	54583	MA12X7R1H223M-T
A4C2960	281-0909-00			CAP,FXD,CER DI:0.022UF,20%,50V	54583	MA12X7R1H223M-T
A4C2970	281-0909-00			CAP,FXD,CER DI:0.022UF,20%,50V	54583	MA12X7R1H223M-T

2445A Replaceable Electrical Parts
2445A/2455A Service

Component No.	Tektronix Part No.	Serial/Assembly No. Effective	Discont	Name & Description	Mfr. Code	Mfr. Part No.
A4C2980	281-0909-00			CAP, FXD, CER 01:0.022UF, 20%, 50V	54583	MA12X7R1H223M-T
A4C2990	281-0909-00			CAP, FXD, CER 01:0.022UF, 20%, 50V	54583	MA12X7R1H223M-T
A4R2805	315-0472-00	8010100	8010105	RES, FXD, FILM:4.7K OHM, 5%, 0.25M	57668	NTR25J-ED4K7
A4R2805	313-1472-00	8010106		RES, FXD, FILM:4.7K OHM, 5%, 0.2M	57668	TR20JE 04K7
A4R2830	315-0101-00	8010100	8010105	RES, FXD, FILM:100 OHM, 5%, 0.25M	57668	NTR25J-E 100E
A4R2830	313-1101-00	8010106		RES, FXD, FILM:100 OHM, 5%, 0.2M	57668	TR20JE100E
A4R2841	315-0103-00	8010100	8010105	RES, FXD, FILM:10K OHM, 5%, 0.25M	19701	5043CX10K00J
A4R2841	313-1103-00	8010106		RES, FXD, FILM:10K OHM, 5%, 0.2M	57668	TR20JE10K0
A4R2842	313-1103-00			RES, FXD, FILM:10K OHM, 5%, 0.2M	57668	TR20JE10K0
A4R2843	313-1472-00			RES, FXD, FILM:4.7K OHM, 5%, 0.2M	57668	TR20JE 04K7
A4R2844	313-1472-00			RES, FXD, FILM:4.7K OHM, 5%, 0.2M	57668	TR20JE 04K7
A4R2850	315-0472-00	8010100	8010105	RES, FXD, FILM:4.7K OHM, 5%, 0.25M	57668	NTR25J-ED4K7
A4R2850	313-1472-00	8010106		RES, FXD, FILM:4.7K OHM, 5%, 0.2M	57668	TR20JE 04K7
A4R2901	315-0103-00	8010100	8010105	RES, FXD, FILM:10K OHM, 5%, 0.25M	19701	5043CX10K00J
A4R2901	313-1103-00	8010106		RES, FXD, FILM:10K OHM, 5%, 0.2M	57668	TR20JE10K0
A4R2902	315-0102-00	8010100	8010105	RES, FXD, FILM:1K OHM, 5%, 0.25M	57668	NTR25JED1K0
A4R2902	313-1102-00	8010106		RES, FXD, FILM:1K OHM, 5%, 0.2M	57668	TR20JED1K0
A4R2903	321-1296-03			RES, FXD, FILM:12.0K OHM, 0.25%, 0.125M, TC=T2	07716	CEAC12001C
A4R2905	321-0816-03			RES, FXD, FILM:5K OHM, 0.25%, 0.125M, TC=T2	19701	5033RC5K000C
A4R2910	321-0685-00			RES, FXD, FILM:30K OHM, 0.5%, 0.125M, TC=T2	19701	5033RC30K000
A4R2911	321-0685-00			RES, FXD, FILM:30K OHM, 0.5%, 0.125M, TC=T2	19701	5033RC30K000
A4R2912	315-0102-00	8010100	8010105	RES, FXD, FILM:1K OHM, 5%, 0.25M	57668	NTR25JED1K0
A4R2912	313-1102-00	8010106		RES, FXD, FILM:1K OHM, 5%, 0.2M	57668	TR20JED1K0
A4R2913	321-0198-00			RES, FXD, FILM:1.13K OHM, 1%, 0.125M, TC=TO	07716	CEAD11300F
A4R2914	321-0306-00			RES, FXD, FILM:15.0K OHM, 1%, 0.125M, TC=TO	19701	5033ED15J00F
A4R2915	315-0202-00	8010100	8010105	RES, FXD, FILM:2K OHM, 5%, 0.25M	57668	NTR25J-E 2K
A4R2915	313-1202-00	8010106		RES, FXD, FILM:2K OHM, 5%, 0.2M	57668	TR20JED2K0
A4R2916	322-3414-00			RES, FXD, FILM:200K OHM, 1%, 0.2M, TC=TO	91637	CCF50G20002F
A4R2917	322-3385-00			RES, FXD, FILM:100K OHM, 1%, 0.2M, TC=TO	57668	CR820 FXE 100K
A4R2918	311-2270-00			RES, VAR, NONNH:TRMR, 10K OHM, 20%, 0.5M	TK1450	GF06VT 10 K OHM
A4R2919	322-3385-00			RES, FXD, FILM:100K OHM, 1%, 0.2M, TC=TO	57668	CR820 FXE 100K
A4R2920	315-0334-00	8010100	8010105	RES, FXD, FILM:330K OHM, 5%, 0.25M	57668	NTR25J-E 330K
A4R2920	313-1334-00	8010106		RES, FXD, FILM:330K OHM, 5%, 0.2M	80009	313-1334-00
A4R2921	321-0724-03			RES, FXD, FILM:13.6K OHM, 0.125%, 0.125M, TC=T2	24546	NC55C1362C
A4R2922	321-0756-00			RES, FXD, FILM:50K OHM, 1%, 0.125M, TC=TO	24546	NA5505002F
A4R2923	321-0385-00			RES, FXD, FILM:100K OHM, 1%, 0.125M, TC=TO	19701	5033ED100K0F
A4R2924	321-0414-00			RES, FXD, FILM:200K OHM, 1%, 0.125M, TC=TO	07716	CEAD20002F
A4R2925	321-0235-02			RES, FXD, FILM:2.74K OHM, 0.5%, 0.125M, TC=T2	24546	NC55C27410
A4R2926	322-3214-00			RES, FXD, FILM:1.65K OHM, 1%, 0.2M, TC=TO	57668	CR8 20 FXE 1K65
A4R2927	315-0203-00	8010100	8010105	RES, FXD, FILM:20K OHM, 5%, 0.25M	57668	NTR25J-E 20K
A4R2927	313-1203-00	8010106		RES, FXD, FILM:20K OHM, 5%, 0.2M	57668	TR20JE20K
A4R2928	313-1472-00			RES, FXD, FILM:4.7K OHM, 5%, 0.2M	57668	TR20JE 04K7
A4R2929	313-1472-00			RES, FXD, FILM:4.7K OHM, 5%, 0.2M	57668	TR20JE 04K7
A4R2930	313-1152-00			RES, FXD, FILM:1.5K OHM, 5%, 0.2M	57668	TR20JED1K5
A4R2931	311-2258-00			RES, VAR, NONNH:TRMR, 1K OHM, 20%, 0.5M	TK1450	GF06VT 1 K OHM
A4R2932	322-3414-00			RES, FXD, FILM:200K OHM, 1%, 0.2M, TC=TO	91637	CCF50G20002F
A4R2933	322-3385-00			RES, FXD, FILM:100K OHM, 1%, 0.2M, TC=TO	57668	CR820 FXE 100K
A4R2940	315-0102-00	8010100	8010105	RES, FXD, FILM:1K OHM, 5%, 0.25M	57668	NTR25JED1K0
A4R2940	313-1102-00	8010106		RES, FXD, FILM:1K OHM, 5%, 0.2M	57668	TR20JED1K0
A4R2945	315-0471-00	8010100	8010105	RES, FXD, FILM:470 OHM, 5%, 0.25M	57668	NTR25J-E470E
A4R2945	313-1471-00	8010106		RES, FXD, FILM:470 OHM, 5%, 0.2M	57668	TR20JE 470E
A4R2975	315-0472-00	8010100	8010105	RES, FXD, FILM:4.7K OHM, 5%, 0.25M	57668	NTR25J-ED4K7
A4R2975	313-1472-00	8010106		RES, FXD, FILM:4.7K OHM, 5%, 0.2M	57668	TR20JE 04K7
A4R2985	315-0102-00	8010100	8010105	RES, FXD, FILM:1K OHM, 5%, 0.25M	57668	NTR25JED1K0
A4R2985	313-1102-00	8010106		RES, FXD, FILM:1K OHM, 5%, 0.2M	57668	TR20JED1K0
A4U2800	156-0514-01			MICROCKT, DGTL:OIFF 4-CHANNEL MUX, SEL	80009	156-0514-01
A4U2805	156-0514-01			MICROCKT, DGTL:OIFF 4-CHANNEL MUX, SEL	80009	156-0514-01
A4U2810	156-0382-02			MICROCKT, DGTL:QUAD 2 INP NAND GATE BURN	18324	N74LS00NB
A4U2820	156-1191-01			MICROCKT, LINEAR:DUAL BI-FET OP-AMP, 8 DIP	80009	156-1191-01

2445A Replaceable Electrical Parts
2445A/2455A Service

Component No.	Tektronix Part No.	Serial/Assembly No. Effective Dscont	Name & Description	Mfr. Code	Mfr. Part No.
A4U2830	156-1172-01		MICROCKT,DGTL:DUAL 4 BIT BIN CNTR	01295	SN74LS393NP3
A4U2835	156-0479-02		MICROCKT,DGTL:QUAD 2-IMP OR GATE	01295	SN74LS32NP3
A4U2850	156-0388-03		MICROCKT,DGTL:DUAL D FLIP-FLOP	01295	SN74LS74ANP3
A4U2855	156-0383-02		MICROCKT,DGTL:QUAD 2-IMP NOR GATE	18324	N74LS02NB
A4U2860	156-0975-02		MICROCKT,DGTL:UNIV SHIFT/STORAGE REGISTER	34335	DM74LS299N-B
A4U2865	156-0796-01		MICROCKT,DGTL:8 STG SHF & STORE BUS RGTR	02735	CD40948FX
A4U2870	156-1172-01		MICROCKT,DGTL:DUAL 4 BIT BIN CNTR	01295	SN74LS393NP3
A4U2880	156-0388-03		MICROCKT,DGTL:DUAL D FLIP-FLOP	01295	SN74LS74ANP3
A4U2885	156-0386-02		MICROCKT,DGTL:TRIPLE 3-IMP NAND GATE	07263	74LS10PCQR
A4U2890	156-0382-02		MICROCKT,DGTL:QUAD 2 IMP NAND GATE BURN	18324	N74LS00NB
A4U2900	156-0386-02		MICROCKT,DGTL:TRIPLE 3-IMP NAND GATE	07263	74LS10PCQR
A4U2905	156-0982-03		MICROCKT,DGTL:OCTAL-D-EDGE TRIG FF	01295	SN74LS374N3
A4U2910	156-1555-00		MICROCKT,LINEAR:D/A CONVERTER	34335	AM6080PC
A4U2920	156-1594-00		MICROCKT,DGTL:MMOS,2048 X 8 SRAM	TK1015	HM6116P-3(OP-24)
A4U2930	160-1631-02		MICROCKT,DGTL:4096 X 8 EPROM,PRGM	80009	160-1631-02
A4U2935	156-0956-02		MICROCKT,DGTL:OCTAL BFR W/3 STATE OUT	01295	SN74LS244NP3
A4U2940	156-1172-01		MICROCKT,DGTL:DUAL 4 BIT BIN CNTR	01295	SN74LS393NP3
A4U2950	156-0388-03		MICROCKT,DGTL:DUAL D FLIP-FLOP	01295	SN74LS74ANP3
A4U2960	156-0796-01		MICROCKT,DGTL:8 STG SHF & STORE BUS RGTR	02735	CD40948FX
A4U2965	156-0382-02		MICROCKT,DGTL:QUAD 2 IMP NAND GATE BURN	18324	N74LS00NB
A4U2970	156-0480-02		MICROCKT,DGTL:QUAD 2-IMP & GATE	01295	SN74LS08NP3
A4U2980	156-0382-02		MICROCKT,DGTL:QUAD 2 IMP NAND GATE BURN	18324	N74LS00NB
A4U2985	156-0768-01		MICROCKT,DGTL:8 BIDIRECT UNIV SR,SCREENED	01295	SN74LS194ANP3
A4U2990	156-0381-02		MICROCKT,DGTL:QUAD 2-IMP EXCL OR GATE	07263	74LS86PCQR
A4U2995	156-0651-02		MICROCKT,DGTL:8-BIT PRL-OUT SER SHF RGTR	01295	SN74LS164NP3
A4VR2805	152-0217-00		SEMICOND DVC,DI:ZEN,SI,8.2V,5%,0.4M,00-7	04713	SZG20
A4VR2925	152-0662-00		SEMICOND DVC,DI:ZEN,SI,5V,1%,400MM,00-7	04713	SZG195RL
A4M411	175-4581-01		CA ASSY,SP,ELEC:28,28 AMG,2.25 L,RIBBON	22526	ORDER BY DESC
A4M2851	131-0566-00		BUS,COND:DUMMY RES,0.094 00 X 0.225L	24546	OWA 07
A4M2913	131-0566-00		BUS,COND:DUMMY RES,0.094 00 X 0.225L	24546	OWA 07
A5	670-9052-00		CIRCUIT BD ASSY:DIGITAL CONTROL	80009	670-9052-00
A5BT2570	146-0049-00		BATTERY,STORAGE:3.5V,750MAH	81855	LTC-7P
A5C2010	290-0943-01		CAP,FXD,ELCTLT:47UF,20%,25V	55680	ULB1E470MPAANA1T
A5C2011	290-0943-01		CAP,FXD,ELCTLT:47UF,20%,25V	55680	ULB1E470MPAANA1T
A5C2101	281-0909-00		CAP,FXD,CER DI:0.022UF,20%,50V	54583	MA12X7R1H223M-T
A5C2110	281-0814-00		CAP,FXD,CER DI:100 PF,10%,100V	04222	MA101A101KAA
A5C2111	281-0909-00		CAP,FXD,CER DI:0.022UF,20%,50V	54583	MA12X7R1H223M-T
A5C2112	281-0909-00		CAP,FXD,CER DI:0.022UF,20%,50V	54583	MA12X7R1H223M-T
A5C2113	290-0943-01		CAP,FXD,ELCTLT:47UF,20%,25V	55680	ULB1E470MPAANA1T
A5C2160	281-0909-00		CAP,FXD,CER DI:0.022UF,20%,50V	54583	MA12X7R1H223M-T
A5C2220	281-0909-00		CAP,FXD,CER DI:0.022UF,20%,50V	54583	MA12X7R1H223M-T
A5C2221	281-0909-00		CAP,FXD,CER DI:0.022UF,20%,50V	54583	MA12X7R1H223M-T
A5C2230	281-0909-00		CAP,FXD,CER DI:0.022UF,20%,50V	54583	MA12X7R1H223M-T
A5C2240	281-0909-00		CAP,FXD,CER DI:0.022UF,20%,50V	54583	MA12X7R1H223M-T
A5C2320	281-0909-00		CAP,FXD,CER DI:0.022UF,20%,50V	54583	MA12X7R1H223M-T
A5C2321	285-1301-01		CAP,FXD,MTLZD:0.47UF,10%,50V	55112	1850.47K50A88
A5C2322	285-1348-00		CAP,FXD,MTLZD:0.22UF,10%,63V	55112	1850.22K63A88
A5C2330	285-1301-01		CAP,FXD,MTLZD:0.47UF,10%,50V	55112	1850.47K50A88
A5C2331	285-1348-00		CAP,FXD,MTLZD:0.22UF,10%,63V	55112	1850.22K63A88
A5C2332	285-1300-01		CAP,FXD,MTLZD:0.1UF,10%,63V	55112	185/0.1/K/63/ABA
A5C2333	285-1300-01		CAP,FXD,MTLZD:0.1UF,10%,63V	55112	185/0.1/K/63/ABA
A5C2340	281-0909-00		CAP,FXD,CER DI:0.022UF,20%,50V	54583	MA12X7R1H223M-T
A5C2350	290-0527-00		CAP,FXD,ELCTLT:15UF,20%,20V	05397	T3688156M020AS
A5C2351	281-0909-00		CAP,FXD,CER DI:0.022UF,20%,50V	54583	MA12X7R1H223M-T
A5C2360	281-0909-00		CAP,FXD,CER DI:0.022UF,20%,50V	54583	MA12X7R1H223M-T
A5C2420	290-0943-01		CAP,FXD,ELCTLT:47UF,20%,25V	55680	ULB1E470MPAANA1T

2445A Replaceable Electrical Parts
2445A/2455A Service

Component No.	Tektronix Part No.	Serial/Assembly No. Effective Dscont	Name & Description	Mfr. Code	Mfr. Part No.
A5C2421	285-1300-01		CAP,FXD,MTLZD:0.1UF,10%,63V	55112	185/0.1/K/63/ABA
A5C2422	281-0791-00		CAP,FXD,CER DI:270PF,10%,100V	04222	NA101C271KAA
A5C2430	285-1301-01		CAP,FXD,MTLZD:0.47UF,10%,50V	55112	1850.47K50A88
A5C2431	285-1348-00		CAP,FXD,MTLZD:0.22UF,10%,63V	55112	1850.22K63A88
A5C2432	285-1348-00		CAP,FXD,MTLZD:0.22UF,10%,63V	55112	1850.22K63A88
A5C2450	281-0909-00		CAP,FXD,CER DI:0.022UF,20%,50V	54583	NA12X7R1H223M-T
A5C2470	290-0527-00		CAP,FXD,ELCTLT:15UF,20%,20V	05397	T3688156M020AS
A5C2501	281-0909-00		CAP,FXD,CER DI:0.022UF,20%,50V	54583	NA12X7R1H223M-T
A5C2510	281-0909-00		CAP,FXD,CER DI:0.022UF,20%,50V	54583	NA12X7R1H223M-T
A5C2511	281-0791-00		CAP,FXD,CER DI:270PF,10%,100V	04222	NA101C271KAA
A5C2520	281-0909-00		CAP,FXD,CER DI:0.022UF,20%,50V	54583	NA12X7R1H223M-T
A5C2521	281-0909-00		CAP,FXD,CER DI:0.022UF,20%,50V	54583	NA12X7R1H223M-T
A5C2530	281-0909-00		CAP,FXD,CER DI:0.022UF,20%,50V	54583	NA12X7R1H223M-T
A5C2550	281-0819-00		CAP,FXD,CER DI:33 PF,5%,50V	04222	GC105A330J
A5C2551	281-0816-00		CAP,FXD,CER DI:82 PF,5%,100V	04222	NA106A820JAA
A5C2552	281-0909-00		CAP,FXD,CER DI:0.022UF,20%,50V	54583	NA12X7R1H223M-T
A5C2601	281-0909-00		CAP,FXD,CER DI:0.022UF,20%,50V	54583	NA12X7R1H223M-T
A5C2610	281-0909-00		CAP,FXD,CER DI:0.022UF,20%,50V	54583	NA12X7R1H223M-T
A5C2620	281-0909-00		CAP,FXD,CER DI:0.022UF,20%,50V	54583	NA12X7R1H223M-T
A5C2621	285-1300-01		CAP,FXD,MTLZD:0.1UF,10%,63V	55112	185/0.1/K/63/ABA
A5C2622	285-1348-00		CAP,FXD,MTLZD:0.22UF,10%,63V	55112	1850.22K63A88
A5C2630	285-1300-01		CAP,FXD,MTLZD:0.1UF,10%,63V	55112	185/0.1/K/63/ABA
A5C2631	285-1348-00		CAP,FXD,MTLZD:0.22UF,10%,63V	55112	1850.22K63A88
A5C2632	281-0909-00		CAP,FXD,CER DI:0.022UF,20%,50V	54583	NA12X7R1H223M-T
A5C2640	285-1300-01		CAP,FXD,MTLZD:0.1UF,10%,63V	55112	185/0.1/K/63/ABA
A5C2650	281-0909-00		CAP,FXD,CER DI:0.022UF,20%,50V	54583	NA12X7R1H223M-T
A5C2660	281-0909-00		CAP,FXD,CER DI:0.022UF,20%,50V	54583	NA12X7R1H223M-T
A5C2720	285-1301-01		CAP,FXD,MTLZD:0.47UF,10%,50V	55112	1850.47K50A88
A5C2721	285-1348-00		CAP,FXD,MTLZD:0.22UF,10%,63V	55112	1850.22K63A88
A5C2730	285-1348-00		CAP,FXD,MTLZD:0.22UF,10%,63V	55112	1850.22K63A88
A5C2731	285-1301-01		CAP,FXD,MTLZD:0.47UF,10%,50V	55112	1850.47K50A88
A5C2732	285-1301-01		CAP,FXD,MTLZD:0.47UF,10%,50V	55112	1850.47K50A88
A5C2733	285-1301-01		CAP,FXD,MTLZD:0.47UF,10%,50V	55112	1850.47K50A88
A5C2740	281-0909-00		CAP,FXD,CER DI:0.022UF,20%,50V	54583	NA12X7R1H223M-T
A5C2800	281-0812-00		CAP,FXD,CER DI:1000PF,10%,100V	04222	NA101C102KAA
A5CR2070	152-0141-02		SEMICOND DVC,DI:5M,SI,30V,150MA,30V,00-35	03508	0A2527 (1N4152)
A5CR2071	152-0141-02		SEMICOND DVC,DI:5M,SI,30V,150MA,30V,00-35	03508	0A2527 (1N4152)
A5CR2170	152-0141-02		SEMICOND DVC,DI:5M,SI,30V,150MA,30V,00-35	03508	0A2527 (1N4152)
A5CR2230	152-0141-02		SEMICOND DVC,DI:5M,SI,30V,150MA,30V,00-35	03508	0A2527 (1N4152)
A5CR2231	152-0141-02		SEMICOND DVC,DI:5M,SI,30V,150MA,30V,00-35	03508	0A2527 (1N4152)
A5CR2232	152-0141-02		SEMICOND DVC,DI:5M,SI,30V,150MA,30V,00-35	03508	0A2527 (1N4152)
A5CR2233	152-0141-02		SEMICOND DVC,DI:5M,SI,30V,150MA,30V,00-35	03508	0A2527 (1N4152)
A5CR2370	152-0322-00		SEMICOND DVC,DI:SCHOTTKY BARRIER,SI,15V	50434	5082-2672
A5CR2371	152-0322-00		SEMICOND DVC,DI:SCHOTTKY BARRIER,SI,15V	50434	5082-2672
A5CR2420	152-0141-02		SEMICOND DVC,DI:5M,SI,30V,150MA,30V,00-35	03508	0A2527 (1N4152)
A5CR2610	152-0141-02		SEMICOND DVC,DI:5M,SI,30V,150MA,30V,00-35	03508	0A2527 (1N4152)
A5CR2620	152-0141-02		SEMICOND DVC,DI:5M,SI,30V,150MA,30V,00-35	03508	0A2527 (1N4152)
A5CR2621	152-0141-02		SEMICOND DVC,DI:5M,SI,30V,150MA,30V,00-35	03508	0A2527 (1N4152)
A5CR2622	152-0141-02		SEMICOND DVC,DI:5M,SI,30V,150MA,30V,00-35	03508	0A2527 (1N4152)
A5CR2630	152-0141-02		SEMICOND DVC,DI:5M,SI,30V,150MA,30V,00-35	03508	0A2527 (1N4152)
A5CR2631	152-0141-02		SEMICOND DVC,DI:5M,SI,30V,150MA,30V,00-35	03508	0A2527 (1N4152)
A5CR2640	152-0141-02		SEMICOND DVC,DI:5M,SI,30V,150MA,30V,00-35	03508	0A2527 (1N4152)
A5CR2770	152-0322-00		SEMICOND DVC,DI:SCHOTTKY BARRIER,SI,15V	50434	5082-2672
A5J251	131-3360-00		CONN,RCPT,ELEC:HEADER,RTANG,20 PIN	53387	3592-6002
A5J500	131-3364-00		CONN,RCPT,ELEC:HEADER,STRAIGHT,34 PIN	53387	3594-6002
A5J501	131-0608-00		TERMINAL,PIN:0.365 L X 0.025 BRZ GLD PL (QUANTITY OF 3)	22526	48283-036
A5J503	131-0608-00		TERMINAL,PIN:0.365 L X 0.025 BRZ GLD PL (QUANTITY OF 3)	22526	48283-036

2445A Replaceable Electrical Parts
2445A/2455A Service

Component No.	Tektronix Part No.	Serial/Assembly No. Effective Decont	Name & Description	Mfr. Code	Mfr. Part No.
ASJ651	131-3360-00		CONN,RCPT,ELEC:HEADER,RTANG,20 PIN	53387	3592-6002
ASJ652	131-3360-00		CONN,RCPT,ELEC:HEADER,RTANG,20 PIN	53387	3592-6002
ASQ2070	151-0342-00		TRANSISTOR:PMP,SI,TO-92	07263	S035928
ASQ2270	151-0342-00		TRANSISTOR:PMP,SI,TO-92	07263	S035928
ASQ2320	151-0341-01		TRANSISTOR:PMP,SI,TO-92	04713	TO BE ASSIGNED
ASR2001	313-1101-00		RES,FXD,FILM:100 OHM,5%,0.2M	57668	TR20JE100E
ASR2002	313-1101-00		RES,FXD,FILM:100 OHM,5%,0.2M	57668	TR20JE100E
ASR2004	313-1101-00		RES,FXD,FILM:100 OHM,5%,0.2M	57668	TR20JE100E
ASR2005	313-1101-00		RES,FXD,FILM:100 OHM,5%,0.2M	57668	TR20JE100E
ASR2006	313-1101-00		RES,FXD,FILM:100 OHM,5%,0.2M	57668	TR20JE100E
ASR2007	313-1101-00		RES,FXD,FILM:100 OHM,5%,0.2M	57668	TR20JE100E
ASR2010	311-2234-00		RES,VAR,NONWH:TRMR,5K OHM,20%,0.5M	TK1450	GF06UT 5K
ASR2011	322-3431-00		RES,FXD,FILM:301K OHM,1%,0.2M,TC=TO	57668	CRB20 FXE 301K
ASR2012	322-3289-02		RES,FXD,FILM:10K OHM,0.5%,0.2M,TC=T2	57668	CRB 20 DYE 10K0
ASR2013	322-3289-02		RES,FXD,FILM:10K OHM,0.5%,0.2M,TC=T2	57668	CRB 20 DYE 10K0
ASR2101	313-1101-00		RES,FXD,FILM:100 OHM,5%,0.2M	57668	TR20JE100E
ASR2102	313-1101-00		RES,FXD,FILM:100 OHM,5%,0.2M	57668	TR20JE100E
ASR2103	313-1101-00		RES,FXD,FILM:100 OHM,5%,0.2M	57668	TR20JE100E
ASR2104	313-1101-00		RES,FXD,FILM:100 OHM,5%,0.2M	57668	TR20JE100E
ASR2110	313-1103-00		RES,FXD,FILM:10K OHM,5%,0.2M	57668	TR20JE10K0
ASR2170	313-1512-00		RES,FXD,CMPNSN:5.1K OHM,5%,0.2M	57668	TR20JE 5K1
ASR2170	322-3235-00		RES,FXD,FILM:2.74K OHM,1%,0.2M,TC=TO	57668	CRB20 FXE 2K74
ASR2171	313-1102-00		RES,FXD,FILM:1K OHM,5%,0.2M	57668	TR20JE01K0
ASR2172	313-1102-00		RES,FXD,FILM:1K OHM,5%,0.2M	57668	TR20JE01K0
ASR2201	313-1103-00		RES,FXD,FILM:10K OHM,5%,0.2M	57668	TR20JE10K0
ASR2202	313-1103-00		RES,FXD,FILM:10K OHM,5%,0.2M	57668	TR20JE10K0
ASR2203	313-1103-00		RES,FXD,FILM:10K OHM,5%,0.2M	57668	TR20JE10K0
ASR2204	313-1103-00		RES,FXD,FILM:10K OHM,5%,0.2M	57668	TR20JE10K0
ASR2205	313-1103-00		RES,FXD,FILM:10K OHM,5%,0.2M	57668	TR20JE10K0
ASR2206	313-1103-00		RES,FXD,FILM:10K OHM,5%,0.2M	57668	TR20JE10K0
ASR2220	313-1102-00		RES,FXD,FILM:1K OHM,5%,0.2M	57668	TR20JE01K0
ASR2230	322-3482-02		RES,FXD,FILM:14.2K OHM,0.5%,0.2M,TC=TO	57668	CRB 20 DYE 14K2
ASR2231	313-1102-00		RES,FXD,FILM:1K OHM,5%,0.2M	57668	TR20JE01K0
ASR2232	313-1102-00		RES,FXD,FILM:1K OHM,5%,0.2M	57668	TR20JE01K0
ASR2240	313-1103-00		RES,FXD,FILM:10K OHM,5%,0.2M	57668	TR20JE10K0
ASR2241	313-1104-00		RES,FXD,FILM:100K OHM,5%,0.2M	57668	TR20JE100K
ASR2242	313-1104-00		RES,FXD,FILM:100K OHM,5%,0.2M	57668	TR20JE100K
ASR2243	313-1103-00		RES,FXD,FILM:10K OHM,5%,0.2M	57668	TR20JE10K0
ASR2244	313-1103-00		RES,FXD,FILM:10K OHM,5%,0.2M	57668	TR20JE10K0
ASR2250	313-1102-00		RES,FXD,FILM:1K OHM,5%,0.2M	57668	TR20JE01K0
ASR2251	313-1102-00		RES,FXD,FILM:1K OHM,5%,0.2M	57668	TR20JE01K0
ASR2301	313-1103-00		RES,FXD,FILM:10K OHM,5%,0.2M	57668	TR20JE10K0
ASR2302	313-1103-00		RES,FXD,FILM:10K OHM,5%,0.2M	57668	TR20JE10K0
ASR2303	313-1103-00		RES,FXD,FILM:10K OHM,5%,0.2M	57668	TR20JE10K0
ASR2304	313-1103-00		RES,FXD,FILM:10K OHM,5%,0.2M	57668	TR20JE10K0
ASR2305	313-1103-00		RES,FXD,FILM:10K OHM,5%,0.2M	57668	TR20JE10K0
ASR2306	313-1103-00		RES,FXD,FILM:10K OHM,5%,0.2M	57668	TR20JE10K0
ASR2320	313-1203-00		RES,FXD,FILM:20K OHM,5%,0.2M	57668	TR20JE20K
ASR2330	322-3360-02		RES,FXD,FILM:54.9K OHM,0.5%,0.2M,TC=T2	57668	CRB20 DYE 54K9
ASR2331	322-3235-00		RES,FXD,FILM:2.74K OHM,1%,0.2M,TC=TO	57668	CRB20 FXE 2K74
ASR2332	322-3193-00		RES,FXD,FILM:1K OHM,1%,0.2M,TC=TO	57668	CRB20 FXE 1K00
ASR2333	322-3235-00		RES,FXD,FILM:2.74K OHM,1%,0.2M,TC=TO	57668	CRB20 FXE 2K74
ASR2334	322-3193-00		RES,FXD,FILM:1K OHM,1%,0.2M,TC=TO	57668	CRB20 FXE 1K00
ASR2340	313-1103-00		RES,FXD,FILM:10K OHM,5%,0.2M	57668	TR20JE10K0
ASR2341	313-1103-00		RES,FXD,FILM:10K OHM,5%,0.2M	57668	TR20JE10K0
ASR2342	313-1103-00		RES,FXD,FILM:10K OHM,5%,0.2M	57668	TR20JE10K0
ASR2343	313-1104-00		RES,FXD,FILM:100K OHM,5%,0.2M	57668	TR20JE100K
ASR2344	313-1104-00		RES,FXD,FILM:100K OHM,5%,0.2M	57668	TR20JE100K
ASR2345	313-1102-00		RES,FXD,FILM:1K OHM,5%,0.2M	57668	TR20JE01K0

2445A Replaceable Electrical Parts
2445A/2455A Service

Component No.	Tektronix Part No.	Serial/Assembly No. Effective Dscont	Name & Description	Mfr. Code	Mfr. Part No.
A5R2346	313-1103-00		RES,FXD,FILM:10K OHM,5%,0.2M	57668	TR20JE10K0
A5R2370	313-1102-00		RES,FXD,FILM:1K OHM,5%,0.2M	57668	TR20JE01K0
A5R2401	313-1103-00		RES,FXD,FILM:10K OHM,5%,0.2M	57668	TR20JE10K0
A5R2402	313-1103-00		RES,FXD,FILM:10K OHM,5%,0.2M	57668	TR20JE10K0
A5R2403	313-1103-00		RES,FXD,FILM:10K OHM,5%,0.2M	57668	TR20JE10K0
A5R2404	313-1103-00		RES,FXD,FILM:10K OHM,5%,0.2M	57668	TR20JE10K0
A5R2405	313-1104-00		RES,FXD,FILM:100K OHM,5%,0.2M	57668	TR20JE100K
A5R2406	313-1104-00		RES,FXD,FILM:100K OHM,5%,0.2M	57668	TR20JE100K
A5R2407	313-1103-00		RES,FXD,FILM:10K OHM,5%,0.2M	57668	TR20JE10K0
A5R2408	313-1103-00		RES,FXD,FILM:10K OHM,5%,0.2M	57668	TR20JE10K0
A5R2409	313-1103-00		RES,FXD,FILM:10K OHM,5%,0.2M	57668	TR20JE10K0
A5R2410	313-1104-00		RES,FXD,FILM:100K OHM,5%,0.2M	57668	TR20JE100K
A5R2411	313-1103-00		RES,FXD,FILM:10K OHM,5%,0.2M	57668	TR20JE10K0
A5R2412	313-1104-00		RES,FXD,FILM:100K OHM,5%,0.2M	57668	TR20JE100K
A5R2413	313-1103-00		RES,FXD,FILM:10K OHM,5%,0.2M	57668	TR20JE10K0
A5R2414	313-1103-00		RES,FXD,FILM:10K OHM,5%,0.2M	57668	TR20JE10K0
A5R2415	313-1103-00		RES,FXD,FILM:10K OHM,5%,0.2M	57668	TR20JE10K0
A5R2416	313-1103-00		RES,FXD,FILM:10K OHM,5%,0.2M	57668	TR20JE10K0
A5R2417	313-1103-00		RES,FXD,FILM:10K OHM,5%,0.2M	57668	TR20JE10K0
A5R2420	313-1103-00		RES,FXD,FILM:10K OHM,5%,0.2M	57668	TR20JE10K0
A5R2421	322-3300-02		RES,FXD,FILM:13K OHM,0.5%,0.2M,TC=T2	57668	CRB20 OYE 13K0
A5R2422	322-3482-02		RES,FXD,FILM:14.2K OHM,0.5%,0.2M,TC=T0	57668	CRB 20 OYE 14K2
A5R2430	322-3289-02		RES,FXD,FILM:10K OHM,0.5%,0.2M,TC=T2	57668	CRB 20 OYE 10K0
A5R2431	313-1101-00		RES,FXD,FILM:100 OHM,5%,0.2M	57668	TR20JE100E
A5R2432	322-3325-00		RES,FXD,FILM:23.7K OHM,1%,0.2M,TC=T0	57668	CRB20 FXE 23K7
A5R2433	322-3289-02		RES,FXD,FILM:10K OHM,0.5%,0.2M,TC=T2	57668	CRB 20 OYE 10K0
A5R2434	322-3289-02		RES,FXD,FILM:10K OHM,0.5%,0.2M,TC=T2	57668	CRB 20 OYE 10K0
A5R2440	313-1104-00		RES,FXD,FILM:100K OHM,5%,0.2M	57668	TR20JE100K
A5R2441	313-1104-00		RES,FXD,FILM:100K OHM,5%,0.2M	57668	TR20JE100K
A5R2442	313-1104-00		RES,FXD,FILM:100K OHM,5%,0.2M	57668	TR20JE100K
A5R2443	313-1103-00		RES,FXD,FILM:10K OHM,5%,0.2M	57668	TR20JE10K0
A5R2444	313-1103-00		RES,FXD,FILM:10K OHM,5%,0.2M	57668	TR20JE10K0
A5R2470	313-1681-00		RES,FXD,FILM:680 OHM,5%,0.2M	57668	TR20JE 680E
A5R2471	313-1681-00		RES,FXD,FILM:680 OHM,5%,0.2M	57668	TR20JE 680E
A5R2501	313-1103-00		RES,FXD,FILM:10K OHM,5%,0.2M	57668	TR20JE10K0
A5R2502	313-1103-00		RES,FXD,FILM:10K OHM,5%,0.2M	57668	TR20JE10K0
A5R2503	313-1103-00		RES,FXD,FILM:10K OHM,5%,0.2M	57668	TR20JE10K0
A5R2504	313-1103-00		RES,FXD,FILM:10K OHM,5%,0.2M	57668	TR20JE10K0
A5R2505	313-1103-00		RES,FXD,FILM:10K OHM,5%,0.2M	57668	TR20JE10K0
A5R2506	322-3235-00		RES,FXD,FILM:2.74K OHM,1%,0.2M,TC=T0	57668	CRB20 FXE 2K74
A5R2510	313-1103-00		RES,FXD,FILM:10K OHM,5%,0.2M	57668	TR20JE10K0
A5R2511	313-1102-00		RES,FXD,FILM:1K OHM,5%,0.2M	57668	TR20JE01K0
A5R2512	313-1102-00		RES,FXD,FILM:1K OHM,5%,0.2M	57668	TR20JE01K0
A5R2513	313-1103-00		RES,FXD,FILM:10K OHM,5%,0.2M	57668	TR20JE10K0
A5R2520	322-3177-02		RES,FXD,FILM:681 OHM,0.5%,0.2M,TC=T2	57668	CRB 20 OYE 681E
A5R2521	322-3177-02		RES,FXD,FILM:681 OHM,0.5%,0.2M,TC=T2	57668	CRB 20 OYE 681E
A5R2522	313-1103-00		RES,FXD,FILM:10K OHM,5%,0.2M	57668	TR20JE10K0
A5R2523	313-1683-00		RES,FXD,FILM:68K OHM,5%,0.2M	57668	TR20JE 68K
A5R2524	313-1683-00		RES,FXD,FILM:68K OHM,5%,0.2M	57668	TR20JE 68K
A5R2530	315-0106-00		RES,FXD,FILM:10M OHM,5%,0.25M	01121	CB1065
A5R2531	313-1101-00		RES,FXD,FILM:100 OHM,5%,0.2M	57668	TR20JE100E
A5R2532	313-1683-00		RES,FXD,FILM:68K OHM,5%,0.2M	57668	TR20JE 68K
A5R2533	322-3235-00		RES,FXD,FILM:2.74K OHM,1%,0.2M,TC=T0	57668	CRB20 FXE 2K74
A5R2534	322-3235-00		RES,FXD,FILM:2.74K OHM,1%,0.2M,TC=T0	57668	CRB20 FXE 2K74
A5R2535	322-3235-00		RES,FXD,FILM:2.74K OHM,1%,0.2M,TC=T0	57668	CRB20 FXE 2K74
A5R2536	313-1103-00		RES,FXD,FILM:10K OHM,5%,0.2M	57668	TR20JE10K0
A5R2537	313-1102-00		RES,FXD,FILM:1K OHM,5%,0.2M	57668	TR20JE01K0
A5R2540	313-1103-00		RES,FXD,FILM:10K OHM,5%,0.2M	57668	TR20JE10K0
A5R2541	313-1102-00		RES,FXD,FILM:1K OHM,5%,0.2M	57668	TR20JE01K0

2445A Replaceable Electrical Parts
2445A/2455A Service

Component No.	Tektronix Part No.	Serial/Assembly No. Effective Dscont	Name & Description	Mfr. Code	Mfr. Part No.
A5R2542	313-1103-00		RES,FXD,FILM:10K OHM,5%,0.2M	57668	TR20JE10K0
A5R2543	313-1102-00		RES,FXD,FILM:1K OHM,5%,0.2M	57668	TR20JE01K0
A5R2544	313-1681-00		RES,FXD,FILM:680 OHM,5%,0.2M	57668	TR20JE 680E
A5R2545	313-1331-00		RES,FXD,FILM:330 OHM,5%,0.2M	57668	TR20JE 330E
A5R2560	313-1222-00		RES,FXD,FILM:2.2K OHM,5%,0.2M	57668	TR20JE 02K2
A5R2601	313-1681-00		RES,FXD,FILM:680 OHM,5%,0.2M	57668	TR20JE 680E
A5R2602	313-1103-00		RES,FXD,FILM:10K OHM,5%,0.2M	57668	TR20JE10K0
A5R2603	313-1103-00		RES,FXD,FILM:10K OHM,5%,0.2M	57668	TR20JE10K0
A5R2604	322-3193-00		RES,FXD,FILM:1K OHM,1%,0.2M,TC=TO	57668	CR820 FXE 1K00
A5R2610	313-1103-00		RES,FXD,FILM:10K OHM,5%,0.2M	57668	TR20JE10K0
A5R2611	313-1104-00		RES,FXD,FILM:100K OHM,5%,0.2M	57668	TR20JE100K
A5R2612	313-1512-00		RES,FXD,CMPNSN:5.1K OHM,5%,0.2M	57668	TR20JE 5K1
A5R2613	313-1103-00		RES,FXD,FILM:10K OHM,5%,0.2M	57668	TR20JE10K0
A5R2620	313-1103-00		RES,FXD,FILM:10K OHM,5%,0.2M	57668	TR20JE10K0
A5R2621	313-1222-00		RES,FXD,FILM:2.2K OHM,5%,0.2M	57668	TR20JE 02K2
A5R2622	313-1101-00		RES,FXD,FILM:100 OHM,5%,0.2M	57668	TR20JE100E
A5R2623	313-1222-00		RES,FXD,FILM:2.2K OHM,5%,0.2M	57668	TR20JE 02K2
A5R2624	313-1512-00		RES,FXD,CMPNSN:5.1K OHM,5%,0.2M	57668	TR20JE 5K1
A5R2630	322-3193-00		RES,FXD,FILM:1K OHM,1%,0.2M,TC=TO	57668	CR820 FXE 1K00
A5R2631	322-3235-00		RES,FXD,FILM:2.74K OHM,1%,0.2M,TC=TO	57668	CR820 FXE 2K74
A5R2632	322-3193-00		RES,FXD,FILM:1K OHM,1%,0.2M,TC=TO	57668	CR820 FXE 1K00
A5R2640	313-1103-00		RES,FXD,FILM:10K OHM,5%,0.2M	57668	TR20JE10K0
A5R2641	313-1103-00		RES,FXD,FILM:10K OHM,5%,0.2M	57668	TR20JE10K0
A5R2642	313-1103-00		RES,FXD,FILM:10K OHM,5%,0.2M	57668	TR20JE10K0
A5R2643	313-1103-00		RES,FXD,FILM:10K OHM,5%,0.2M	57668	TR20JE10K0
A5R2644	313-1103-00		RES,FXD,FILM:10K OHM,5%,0.2M	57668	TR20JE10K0
A5R2645	313-1103-00		RES,FXD,FILM:10K OHM,5%,0.2M	57668	TR20JE10K0
A5R2660	313-1103-00		RES,FXD,FILM:10K OHM,5%,0.2M	57668	TR20JE10K0
A5R2661	313-1103-00		RES,FXD,FILM:10K OHM,5%,0.2M	57668	TR20JE10K0
A5R2701	313-1103-00		RES,FXD,FILM:10K OHM,5%,0.2M	57668	TR20JE10K0
A5R2702	313-1103-00		RES,FXD,FILM:10K OHM,5%,0.2M	57668	TR20JE10K0
A5R2703	313-1103-00		RES,FXD,FILM:10K OHM,5%,0.2M	57668	TR20JE10K0
A5R2704	313-1103-00		RES,FXD,FILM:10K OHM,5%,0.2M	57668	TR20JE10K0
A5R2705	313-1103-00		RES,FXD,FILM:10K OHM,5%,0.2M	57668	TR20JE10K0
A5R2706	313-1103-00		RES,FXD,FILM:10K OHM,5%,0.2M	57668	TR20JE10K0
A5R2707	313-1103-00		RES,FXD,FILM:10K OHM,5%,0.2M	57668	TR20JE10K0
A5R2708	313-1103-00		RES,FXD,FILM:10K OHM,5%,0.2M	57668	TR20JE10K0
A5R2709	313-1103-00		RES,FXD,FILM:10K OHM,5%,0.2M	57668	TR20JE10K0
A5R2710	313-1103-00		RES,FXD,FILM:10K OHM,5%,0.2M	57668	TR20JE10K0
A5R2711	313-1103-00		RES,FXD,FILM:10K OHM,5%,0.2M	57668	TR20JE10K0
A5R2712	313-1103-00		RES,FXD,FILM:10K OHM,5%,0.2M	57668	TR20JE10K0
A5R2720	313-1103-00		RES,FXD,FILM:10K OHM,5%,0.2M	57668	TR20JE10K0
A5R2721	313-1203-00		RES,FXD,FILM:20K OHM,5%,0.2M	57668	TR20JE20K
A5R2730	313-1203-00		RES,FXD,FILM:20K OHM,5%,0.2M	57668	TR20JE20K
A5R2731	315-0107-00		RES,FXD,FILM:100M OHM,5%,0.25M	01121	CB1075
A5R2732	315-0107-00		RES,FXD,FILM:100M OHM,5%,0.25M	01121	CB1075
A5R2733	322-3235-00		RES,FXD,FILM:2.74K OHM,1%,0.2M,TC=TO	57668	CR820 FXE 2K74
A5R2734	313-1102-00		RES,FXD,FILM:1K OHM,5%,0.2M	57668	TR20JE01K0
A5R2735	313-1102-00		RES,FXD,FILM:1K OHM,5%,0.2M	57668	TR20JE01K0
A5R2740	322-3193-00		RES,FXD,FILM:1K OHM,1%,0.2M,TC=TO	57668	CR820 FXE 1K00
A5R2741	313-1101-00		RES,FXD,FILM:100 OHM,5%,0.2M	57668	TR20JE100E
A5R2742	313-1103-00		RES,FXD,FILM:10K OHM,5%,0.2M	57668	TR20JE10K0
A5R2770	313-1103-00		RES,FXD,FILM:10K OHM,5%,0.2M	57668	TR20JE10K0
A5TP2070	131-0608-00		TERMINAL,PIN:0.365 L X 0.025 BRZ GLD PL	22526	48283-036
A5TP2420	131-0608-00		TERMINAL,PIN:0.365 L X 0.025 BRZ GLD PL	22526	48283-036
A5TP2421	131-0608-00		TERMINAL,PIN:0.365 L X 0.025 BRZ GLD PL	22526	48283-036
A5TP2701	131-0608-00		TERMINAL,PIN:0.365 L X 0.025 BRZ GLD PL	22526	48283-036
ASU2101	156-1589-00		MICROCKT,LINEAR:DAC,12 BIT,HIGH SPEED,MONO	06665	DAC312FR
ASU2140	156-1342-01		MICROCKT,DGTL:NMOS,MPU,8-BIT N/CLK	04713	SC67127P

2445A Replaceable Electrical Parts
2445A/2455A Service

Component No.	Tektronix Part No.	Serial/Assembly No. Effective	Discont	Name & Description	Mfr. Code	Mfr. Part No.
A5U2160	160-3302-03			MICROCKT,DGTL:65536 X 8 EPROM,PRGM	80009	160-3302-03
A5U2201	156-0865-02			MICROCKT,DGTL:OCTAL 0 FF M/CLEAR	01295	SN74LS273NP3
A5U2210	156-0391-02			MICROCKT,DGTL:HEX LATCH M/CLEAR	01295	SN74LS174NP3
A5U2220	156-0956-02			MICROCKT,DGTL:OCTAL BFR M/3 STATE OUT	01295	SN74LS244NP3
A5U2240	156-2396-00			MICROCKT,DGTL:RESET GENERATOR,5V SUPPLY	01295	TL7705 ACP
A5U2250	160-3635-01			MICROCKT,DGTL:OCTAL 16-IN AOI GATE ARRAY	80009	160-3635-01
A5U2260	160-3303-03			MICROCKT,DGTL:65536 X 8 EPROM,PRGM	80009	160-3303-03
A5U2301	156-0865-02			MICROCKT,DGTL:OCTAL 0 FF M/CLEAR	01295	SN74LS273NP3
A5U2310	156-0391-02			MICROCKT,DGTL:HEX LATCH M/CLEAR	01295	SN74LS174NP3
A5U2350	156-0956-02			MICROCKT,DGTL:OCTAL BFR M/3 STATE OUT	01295	SN74LS244NP3
A5U2401	156-0513-03			MICROCKT,LINER:CMOS,8 CHAN ANALOG MUX	04713	MC140518CL
A5U2410	156-1486-00			MICROCKT,DGTL:8 CHANNEL DATA SEL,SCREENED	02735	CD4512BFX
A5U2420	156-1200-01			MICROCKT,LINER:OPERATIONAL AMPL,QUAD BIFET	80009	156-1200-01
A5U2430	156-1200-01			MICROCKT,LINER:OPERATIONAL AMPL,QUAD BIFET	80009	156-1200-01
A5U2440	156-0388-03			MICROCKT,DGTL:DUAL 0 FLIP-FLOP	01295	SN74LS74ANP3
A5U2450	156-1065-01			MICROCKT,DGTL:OCTAL 0 TYPE TRANS LATCHES	04713	SN74LS373 MD/JO
A5U2460	156-2473-00			MICROCKT,DGTL:8192 X 8 SRAM,LOW STANDBY PMR	TK0961	UPD4664C-20
A5U2501	156-0513-03			MICROCKT,LINER:CMOS,8 CHAN ANALOG MUX	04713	MC140518CL
A5U2510	156-1126-01			MICROCKT,LINER:VOLTAGE COMPARATOR,SELECTED	01295	LM311JG4
A5U2520	156-1191-01			MICROCKT,LINER:DUAL BI-FET OP-AMP,8 DIP	80009	156-1191-01
A5U2521	156-0513-03			MICROCKT,LINER:CMOS,8 CHAN ANALOG MUX	04713	MC140518CL
A5U2530	156-0513-03			MICROCKT,LINER:CMOS,8 CHAN ANALOG MUX	04713	MC140518CL
A5U2540	156-1722-00			MICROCKT,DGTL:HEX INVERTER	04713	MC74F04MD
A5U2550	156-0469-02			MICROCKT,DGTL:3/8 LINE DCOR	01295	SN74LS138NP3
A5U2601	156-0513-03			MICROCKT,LINER:CMOS,8 CHAN ANALOG MUX	04713	MC140518CL
A5U2620	156-1200-01			MICROCKT,LINER:OPERATIONAL AMPL,QUAD BIFET	80009	156-1200-01
A5U2630	156-1200-01			MICROCKT,LINER:OPERATIONAL AMPL,QUAD BIFET	80009	156-1200-01
A5U2640	156-0895-01			MICROCKT,DGTL:14 BIT BINARY COUNTER,BURN-IN	02735	CD40208FX
A5U2650	156-0804-02			MICROCKT,DGTL:QUADRUPLE S-R LATCH	01295	SN74LS279NP3/JP4
A5U2660	156-1026-02			MICROCKT,DGTL:4/1 LINE DECODER,SCRN	01295	SN74LS154N P3
A5VR2420	152-0278-00			SEMICOND DVC,01:ZEN,SI,3V,5X,0.4M,DO-7	04713	SZ635009K20
A5M511	174-0002-00			CA ASSY,SP,ELEC:26,28 AWG,2.0 L	80009	174-0002-00
A5M512	174-0001-00			CA ASSY,SP,ELEC:34,28 AWG,2.0 L	80009	174-0001-00
A5M2070	131-0566-00			BUS,COND:DUMMY RES,0.094 00 X 0.225L	24546	QNA 07
A5M2240	131-1817-00			BUS,CONDUCTOR:22AWG,BARE,2.25 L	80009	131-1817-00
A5M2610	131-1817-00			BUS,CONDUCTOR:22AWG,BARE,2.25 L	80009	131-1817-00
A5M2701	131-0566-00			BUS,COND:DUMMY RES,0.094 00 X 0.225L	24546	QNA 07
A5Y2540	158-0248-00			XTAL UNIT,QTZ:10MHZ,0.01%,SERIES	14301	HC-18/U
A6	614-0448-00			FRONT PNL ASSY:STANDARD	80009	614-0448-00
A6P3001	131-3478-00	8010100	8010188	CONN,RCPT,ELEC:VERT,2 X 10,0.1 SPACING	80009	131-3478-00
A6P3001	131-3478-01	8010189		CONN,RCPT,ELEC:VERT,2 X 10,0.1 SPACING	80009	131-3478-01
A6R3007	311-2318-00			RES,VAR,NONHM:5K OHM,30%,0.5M	32997	ADVISE
A6R3008	311-2316-00			RES,VAR,NONHM:2K OHM,20%,0.5M	32997	ADVISE
A6R3009	311-2317-00			RES,VAR,NONHM:5K OHM,30%,0.25M	32997	ADVISE
A6R3010	311-2318-00			RES,VAR,NONHM:5K OHM,30%,0.5M	32997	ADVISE
A6R3011	311-2316-00			RES,VAR,NONHM:2K OHM,20%,0.5M	32997	ADVISE
A6R3012	311-2317-00			RES,VAR,NONHM:5K OHM,30%,0.25M	32997	ADVISE
A6R3013	311-2316-00			RES,VAR,NONHM:2K OHM,20%,0.5M	32997	ADVISE
A6R3014	311-2318-00			RES,VAR,NONHM:5K OHM,30%,0.5M	32997	ADVISE
A6R3015	311-2316-00			RES,VAR,NONHM:2K OHM,20%,0.5M	32997	ADVISE
A6R3016	311-2316-00			RES,VAR,NONHM:2K OHM,20%,0.5M	32997	ADVISE
A6R3017	311-2316-00			RES,VAR,NONHM:2K OHM,20%,0.5M	32997	ADVISE
A6R3018	311-2318-00			RES,VAR,NONHM:5K OHM,30%,0.5M	32997	ADVISE
A6R3019	311-2316-00			RES,VAR,NONHM:2K OHM,20%,0.5M	32997	ADVISE

Component No.	Tektronix Part No.	Serial/Assembly No. Effective Discont	Name & Description	Mfr. Code	Mfr. Part No.
A6A1	-----		CIRCUIT BD ASSY:SYNCHRONIZER		
A6A1C3001	281-0909-00		CAP,FXD,CER DI:0.022UF,20%,50V	54583	MA12X7R1H223M-T
A6A1C3002	281-0909-00		CAP,FXD,CER DI:0.022UF,20%,50V	54583	MA12X7R1H223M-T
A6A1C3019	281-0909-00		CAP,FXD,CER DI:0.022UF,20%,50V	54583	MA12X7R1H223M-T
A6A1CR3001	152-0141-02		SEMICON DVC,DI:SM,SI,30V,150MA,30V,D0-35	03508	DA2527 (1N4152)
A6A1CR3002	152-0141-02		SEMICON DVC,DI:SM,SI,30V,150MA,30V,D0-35	03508	DA2527 (1N4152)
A6A1CR3003	152-0141-02		SEMICON DVC,DI:SM,SI,30V,150MA,30V,D0-35	03508	DA2527 (1N4152)
A6A1CR3004	152-0141-02		SEMICON DVC,DI:SM,SI,30V,150MA,30V,D0-35	03508	DA2527 (1N4152)
A6A1CR3005	152-0141-02		SEMICON DVC,DI:SM,SI,30V,150MA,30V,D0-35	03508	DA2527 (1N4152)
A6A1CR3006	152-0141-02		SEMICON DVC,DI:SM,SI,30V,150MA,30V,D0-35	03508	DA2527 (1N4152)
A6A1CR3007	152-0141-02		SEMICON DVC,DI:SM,SI,30V,150MA,30V,D0-35	03508	DA2527 (1N4152)
A6A1CR3008	152-0141-02		SEMICON DVC,DI:SM,SI,30V,150MA,30V,D0-35	03508	DA2527 (1N4152)
A6A1CR3009	152-0141-02		SEMICON DVC,DI:SM,SI,30V,150MA,30V,D0-35	03508	DA2527 (1N4152)
A6A1CR3010	152-0141-02		SEMICON DVC,DI:SM,SI,30V,150MA,30V,D0-35	03508	DA2527 (1N4152)
A6A1CR3011	152-0141-02		SEMICON DVC,DI:SM,SI,30V,150MA,30V,D0-35	03508	DA2527 (1N4152)
A6A1CR3012	152-0141-02		SEMICON DVC,DI:SM,SI,30V,150MA,30V,D0-35	03508	DA2527 (1N4152)
A6A1CR3013	152-0141-02		SEMICON DVC,DI:SM,SI,30V,150MA,30V,D0-35	03508	DA2527 (1N4152)
A6A1CR3014	152-0141-02		SEMICON DVC,DI:SM,SI,30V,150MA,30V,D0-35	03508	DA2527 (1N4152)
A6A1CR3015	152-0141-02		SEMICON DVC,DI:SM,SI,30V,150MA,30V,D0-35	03508	DA2527 (1N4152)
A6A1CR3016	152-0141-02		SEMICON DVC,DI:SM,SI,30V,150MA,30V,D0-35	03508	DA2527 (1N4152)
A6A1CR3017	152-0141-02		SEMICON DVC,DI:SM,SI,30V,150MA,30V,D0-35	03508	DA2527 (1N4152)
A6A1CR3018	152-0141-02		SEMICON DVC,DI:SM,SI,30V,150MA,30V,D0-35	03508	DA2527 (1N4152)
A6A1CR3019	152-0141-02		SEMICON DVC,DI:SM,SI,30V,150MA,30V,D0-35	03508	DA2527 (1N4152)
A6A1CR3020	152-0141-02		SEMICON DVC,DI:SM,SI,30V,150MA,30V,D0-35	03508	DA2527 (1N4152)
A6A1CR3021	152-0141-02		SEMICON DVC,DI:SM,SI,30V,150MA,30V,D0-35	03508	DA2527 (1N4152)
A6A1CR3022	152-0141-02		SEMICON DVC,DI:SM,SI,30V,150MA,30V,D0-35	03508	DA2527 (1N4152)
A6A1CR3023	152-0141-02		SEMICON DVC,DI:SM,SI,30V,150MA,30V,D0-35	03508	DA2527 (1N4152)
A6A1CR3024	152-0141-02		SEMICON DVC,DI:SM,SI,30V,150MA,30V,D0-35	03508	DA2527 (1N4152)
A6A1CR3025	152-0141-02		SEMICON DVC,DI:SM,SI,30V,150MA,30V,D0-35	03508	DA2527 (1N4152)
A6A1CR3026	152-0141-02		SEMICON DVC,DI:SM,SI,30V,150MA,30V,D0-35	03508	DA2527 (1N4152)
A6A1CR3027	152-0141-02		SEMICON DVC,DI:SM,SI,30V,150MA,30V,D0-35	03508	DA2527 (1N4152)
A6A1CR3028	152-0141-02		SEMICON DVC,DI:SM,SI,30V,150MA,30V,D0-35	03508	DA2527 (1N4152)
A6A1CR3029	152-0141-02		SEMICON DVC,DI:SM,SI,30V,150MA,30V,D0-35	03508	DA2527 (1N4152)
A6A1CR3030	152-0141-02		SEMICON DVC,DI:SM,SI,30V,150MA,30V,D0-35	03508	DA2527 (1N4152)
A6A1CR3031	152-0141-02		SEMICON DVC,DI:SM,SI,30V,150MA,30V,D0-35	03508	DA2527 (1N4152)
A6A1CR3032	152-0141-02		SEMICON DVC,DI:SM,SI,30V,150MA,30V,D0-35	03508	DA2527 (1N4152)
A6A1CR3033	152-0141-02		SEMICON DVC,DI:SM,SI,30V,150MA,30V,D0-35	03508	DA2527 (1N4152)
A6A1CR3034	152-0141-02		SEMICON DVC,DI:SM,SI,30V,150MA,30V,D0-35	03508	DA2527 (1N4152)
A6A1CR3035	152-0141-02		SEMICON DVC,DI:SM,SI,30V,150MA,30V,D0-35	03508	DA2527 (1N4152)
A6A1CR3036	152-0141-02		SEMICON DVC,DI:SM,SI,30V,150MA,30V,D0-35	03508	DA2527 (1N4152)
A6A1CR3037	152-0141-02		SEMICON DVC,DI:SM,SI,30V,150MA,30V,D0-35	03508	DA2527 (1N4152)
A6A1CR3038	152-0141-02		SEMICON DVC,DI:SM,SI,30V,150MA,30V,D0-35	03508	DA2527 (1N4152)
A6A1CR3039	152-0141-02		SEMICON DVC,DI:SM,SI,30V,150MA,30V,D0-35	03508	DA2527 (1N4152)
A6A1CR3040	152-0141-02		SEMICON DVC,DI:SM,SI,30V,150MA,30V,D0-35	03508	DA2527 (1N4152)
A6A1CR3041	152-0141-02		SEMICON DVC,DI:SM,SI,30V,150MA,30V,D0-35	03508	DA2527 (1N4152)
A6A1CR3042	152-0141-02		SEMICON DVC,DI:SM,SI,30V,150MA,30V,D0-35	03508	DA2527 (1N4152)
A6A1CR3043	152-0141-02		SEMICON DVC,DI:SM,SI,30V,150MA,30V,D0-35	03508	DA2527 (1N4152)
A6A1DS3001	150-1161-00		LT EMITTING DIO:YELLOW	50434	QLMP 1487
A6A1DS3002	150-1160-00		LT EMITTING DIO:GREEN	50434	QLMP 1587
A6A1DS3003	150-1160-00		LT EMITTING DIO:GREEN	50434	QLMP 1587
A6A1DS3004	150-1160-00		LT EMITTING DIO:GREEN	50434	QLMP 1587
A6A1DS3005	150-1160-00		LT EMITTING DIO:GREEN	50434	QLMP 1587
A6A1DS3006	150-1161-00		LT EMITTING DIO:YELLOW	50434	QLMP 1487
A6A1DS3007	150-1160-00		LT EMITTING DIO:GREEN	50434	QLMP 1587
A6A1DS3008	150-1160-00		LT EMITTING DIO:GREEN	50434	QLMP 1587
A6A1DS3009	150-1160-00		LT EMITTING DIO:GREEN	50434	QLMP 1587
A6A1DS3010	150-1160-00		LT EMITTING DIO:GREEN	50434	QLMP 1587
A6A1DS3011	150-1160-00		LT EMITTING DIO:GREEN	50434	QLMP 1587
A6A1DS3012	150-1161-00		LT EMITTING DIO:YELLOW	50434	QLMP 1487

2445A Replaceable Electrical Parts
2445A/2455A Service

Component No.	Tektronix Part No.	Serial/Assembly No. Effective Dscont	Name & Description	Mfr. Code	Mfr. Part No.
A6A10S3013	150-1160-00		LT EMITTING DIO:GREEN	50434	QLMP 1587
A6A10S3014	150-1160-00		LT EMITTING DIO:GREEN	50434	QLMP 1587
A6A10S3015	150-1160-00		LT EMITTING DIO:GREEN	50434	QLMP 1587
A6A10S3016	150-1160-00		LT EMITTING DIO:GREEN	50434	QLMP 1587
A6A10S3017	150-1161-00		LT EMITTING DIO:YELLOW	50434	QLMP 1487
A6A10S3018	150-1160-00		LT EMITTING DIO:GREEN	50434	QLMP 1587
A6A10S3019	150-1161-00		LT EMITTING DIO:YELLOW	50434	QLMP 1487
A6A10S3020	150-1160-00		LT EMITTING DIO:GREEN	50434	QLMP 1587
A6A10S3021	150-1161-00		LT EMITTING DIO:YELLOW	50434	QLMP 1487
A6A10S3022	150-1161-00		LT EMITTING DIO:YELLOW	50434	QLMP 1487
A6A10S3023	150-1160-00		LT EMITTING DIO:GREEN	50434	QLMP 1587
A6A10S3024	150-1160-00		LT EMITTING DIO:GREEN	50434	QLMP 1587
A6A10S3025	150-1160-00		LT EMITTING DIO:GREEN	50434	QLMP 1587
A6A10S3026	150-1160-00		LT EMITTING DIO:GREEN	50434	QLMP 1587
A6A10S3027	150-1161-00		LT EMITTING DIO:YELLOW	50434	QLMP 1487
A6A10S3028	150-1161-00		LT EMITTING DIO:YELLOW	50434	QLMP 1487
A6A10S3029	150-1160-00		LT EMITTING DIO:GREEN	50434	QLMP 1587
A6A10S3030	150-1160-00		LT EMITTING DIO:GREEN	50434	QLMP 1587
A6A10S3031	150-1160-00		LT EMITTING DIO:GREEN	50434	QLMP 1587
A6A10S3032	150-1160-00		LT EMITTING DIO:GREEN	50434	QLMP 1587
A6A10S3033	150-1161-00		LT EMITTING DIO:YELLOW	50434	QLMP 1487
A6A10S3034	150-1160-00		LT EMITTING DIO:GREEN	50434	QLMP 1587
A6A10S3035	150-1160-00		LT EMITTING DIO:GREEN	50434	QLMP 1587
A6A10S3036	150-1161-00		LT EMITTING DIO:YELLOW	50434	QLMP 1487
A6A10S3037	150-1160-00		LT EMITTING DIO:GREEN	50434	QLMP 1587
A6A10S3038	150-1160-00		LT EMITTING DIO:GREEN	50434	QLMP 1587
A6A10S3039	150-1160-00		LT EMITTING DIO:GREEN	50434	QLMP 1587
A6A10S3040	150-1160-00		LT EMITTING DIO:GREEN	50434	QLMP 1587
A6A10S3041	150-1161-00		LT EMITTING DIO:YELLOW	50434	QLMP 1487
A6A10S3042	150-1160-00		LT EMITTING DIO:GREEN	50434	QLMP 1587
A6A10S3043	150-1161-00		LT EMITTING DIO:YELLOW	50434	QLMP 1487
A6A10S3044	150-1161-00		LT EMITTING DIO:YELLOW	50434	QLMP 1487
A6A10S3045	150-1161-00		LT EMITTING DIO:YELLOW	50434	QLMP 1487
A6A10S3046	150-1160-00		LT EMITTING DIO:GREEN	50434	QLMP 1587
A6A10S3047	150-1160-00		LT EMITTING DIO:GREEN	50434	QLMP 1587
A6A10S3048	150-1160-00		LT EMITTING DIO:GREEN	50434	QLMP 1587
A6A10S3049	150-1160-00		LT EMITTING DIO:GREEN	50434	QLMP 1587
A6A1R3001	307-0486-00		RES NTWK,FXD,FI:100 OHM,20%,1.125M	11236	750-101-R100 OHM
A6A1R3002	307-0695-00		RES NTWK,FXD,FI:9,150 OHM,2%,0.2M EA	11236	750-101-R150 OHM
A6A1R3003	307-0486-00		RES NTWK,FXD,FI:100 OHM,20%,1.125M	11236	750-101-R100 OHM
A6A1R3004	313-1151-00		RES,FXD,FILM:150 OHM,5%,0.2M	57668	TR20JE150E
A6A1R3005	313-1151-00		RES,FXD,FILM:150 OHM,5%,0.2M	57668	TR20JE150E
A6A1R3006	313-1101-00		RES,FXD,FILM:100 OHM,5%,0.2M	57668	TR20JE100E
A6A1S3001	260-2280-00		SM,PUSH BUTTON:MINI MOM,SPST,NORM OPEN	80009	260-2280-00
A6A1S3002	260-2280-00		SM,PUSH BUTTON:MINI MOM,SPST,NORM OPEN	80009	260-2280-00
A6A1S3003	260-2280-00		SM,PUSH BUTTON:MINI MOM,SPST,NORM OPEN	80009	260-2280-00
A6A1S3004	260-2283-00		SWITCH,ROTARY:VOLTS/DIV	80009	260-2283-00
A6A1S3005	260-2280-00		SM,PUSH BUTTON:MINI MOM,SPST,NORM OPEN	80009	260-2280-00
A6A1S3006	260-2280-00		SM,PUSH BUTTON:MINI MOM,SPST,NORM OPEN	80009	260-2280-00
A6A1S3007	260-2280-00		SM,PUSH BUTTON:MINI MOM,SPST,NORM OPEN	80009	260-2280-00
A6A1S3008	260-2280-00		SM,PUSH BUTTON:MINI MOM,SPST,NORM OPEN	80009	260-2280-00
A6A1S3009	260-2280-00		SM,PUSH BUTTON:MINI MOM,SPST,NORM OPEN	80009	260-2280-00
A6A1S3010	260-2280-00		SM,PUSH BUTTON:MINI MOM,SPST,NORM OPEN	80009	260-2280-00
A6A1S3011	260-2280-00		SM,PUSH BUTTON:MINI MOM,SPST,NORM OPEN	80009	260-2280-00
A6A1S3012	260-2280-00		SM,PUSH BUTTON:MINI MOM,SPST,NORM OPEN	80009	260-2280-00
A6A1S3013	260-2283-00		SWITCH,ROTARY:VOLTS/DIV	80009	260-2283-00
A6A1S3014	260-2280-00		SM,PUSH BUTTON:MINI MOM,SPST,NORM OPEN	80009	260-2280-00
A6A1S3015	260-2280-00		SM,PUSH BUTTON:MINI MOM,SPST,NORM OPEN	80009	260-2280-00
A6A1S3016	260-2280-00		SM,PUSH BUTTON:MINI MOM,SPST,NORM OPEN	80009	260-2280-00

2445A Replaceable Electrical Parts
2445A/2455A Service

Component No.	Tektronix Part No.	Serial/Assembly No. Effective Dscont	Name & Description	Mfr. Code	Mfr. Part No.
A6A1S3017	260-2280-00		SM,PUSH BUTTON:MINI WOM,SPST,NORM OPEN	80009	260-2280-00
A6A1S3018	260-2280-00		SM,PUSH BUTTON:MINI WOM,SPST,NORM OPEN	80009	260-2280-00
A6A1S3019	260-2283-00		SWITCH,ROTARY:VOLTS/DIV	80009	260-2283-00
A6A1S3020	260-2280-00		SM,PUSH BUTTON:MINI WOM,SPST,NORM OPEN	80009	260-2280-00
A6A1S3021	260-2164-01		SWITCH,SLIDE:SPDT,4A,20VAC	09353	1101 AV2 BE2
A6A1S3022	260-2280-00		SM,PUSH BUTTON:MINI WOM,SPST,NORM OPEN	80009	260-2280-00
A6A1S3023	260-2280-00		SM,PUSH BUTTON:MINI WOM,SPST,NORM OPEN	80009	260-2280-00
A6A1S3024	260-2280-00		SM,PUSH BUTTON:MINI WOM,SPST,NORM OPEN	80009	260-2280-00
A6A1S3025	260-2280-00		SM,PUSH BUTTON:MINI WOM,SPST,NORM OPEN	80009	260-2280-00
A6A1S3026	260-2280-00		SM,PUSH BUTTON:MINI WOM,SPST,NORM OPEN	80009	260-2280-00
A6A1S3027	260-2280-00		SM,PUSH BUTTON:MINI WOM,SPST,NORM OPEN	80009	260-2280-00
A6A1S3028	260-2280-00		SM,PUSH BUTTON:MINI WOM,SPST,NORM OPEN	80009	260-2280-00
A6A1S3029	260-2280-00		SM,PUSH BUTTON:MINI WOM,SPST,NORM OPEN	80009	260-2280-00
A6A1S3030	260-2280-00		SM,PUSH BUTTON:MINI WOM,SPST,NORM OPEN	80009	260-2280-00
A6A1S3031	260-2280-00		SM,PUSH BUTTON:MINI WOM,SPST,NORM OPEN	80009	260-2280-00
A6A1S3032	260-2280-00		SM,PUSH BUTTON:MINI WOM,SPST,NORM OPEN	80009	260-2280-00
A6A1S3033	260-2280-00		SM,PUSH BUTTON:MINI WOM,SPST,NORM OPEN	80009	260-2280-00
A6A1S3034	260-2280-00		SM,PUSH BUTTON:MINI WOM,SPST,NORM OPEN	80009	260-2280-00
A6A1U3001	156-2120-00		MICROCKT,DGTL:SERIAL-IN PARALLEL-OUT SHIFT	07263	74F164PCQR/DCQR
A6A1U3002	156-2120-00		MICROCKT,DGTL:SERIAL-IN PARALLEL-OUT SHIFT	07263	74F164PCQR/DCQR
A6A1U3003	156-2120-00		MICROCKT,DGTL:SERIAL-IN PARALLEL-OUT SHIFT	07263	74F164PCQR/DCQR
A6A1U3004	156-2120-00		MICROCKT,DGTL:SERIAL-IN PARALLEL-OUT SHIFT	07263	74F164PCQR/DCQR
A6A1U3005	156-2120-00		MICROCKT,DGTL:SERIAL-IN PARALLEL-OUT SHIFT	07263	74F164PCQR/DCQR
A6A1U3006	156-2120-00		MICROCKT,DGTL:SERIAL-IN PARALLEL-OUT SHIFT	07263	74F164PCQR/DCQR
A8	670-7280-00		CIRCUIT BD ASSY:SCALE ILLUM	80009	670-7280-00
A8D5100	150-0057-01		LAMP,INCAND:5V,0.115A,WIRE LD,AGED & SEL	71744	7153 AS 15
A8D5101	150-0057-01		LAMP,INCAND:5V,0.115A,WIRE LD,AGED & SEL	71744	7153 AS 15
A8D5102	150-0057-01		LAMP,INCAND:5V,0.115A,WIRE LD,AGED & SEL	71744	7153 AS 15
A9	670-7277-08		CIRCUIT BD ASSY:HIGH VOLTAGE	80009	670-7277-08
A9C91	283-0084-00		CAP,FXD,CER DI:270PF,5%,1000V	59660	838533X5FU2715
A9C1812	285-1236-00		CAP,FXD,PLASTIC:0.022UF,20%,400V	14752	23001E223M
A9C1813	285-1236-00		CAP,FXD,PLASTIC:0.022UF,20%,400V	14752	23001E223M
A9C1870	281-0773-00		CAP,FXD,CER DI:0.01UF,10%,100V	04222	MA201C103KAA
A9C1886	285-1236-00		CAP,FXD,PLASTIC:0.022UF,20%,400V	14752	23001E223M
A9C1888	285-1236-00		CAP,FXD,PLASTIC:0.022UF,20%,400V	14752	23001E223M
A9C1889	285-1236-00		CAP,FXD,PLASTIC:0.022UF,20%,400V	14752	23001E223M
A9C1890	281-0775-00		CAP,FXD,CER DI:0.1UF,20%,50V	04222	MA205E104MAA
A9C1891	281-0775-00		CAP,FXD,CER DI:0.1UF,20%,50V	04222	MA205E104MAA
A9C1912	281-0798-00		CAP,FXD,CER DI:51PF,1%,100V	04222	MA101A510GAA
A9C1915	281-0783-00		CAP,FXD,CER DI:0.1 UF 20%,100V	04222	MA401C104MAA
A9C1932	281-0775-00		CAP,FXD,CER DI:0.1UF,20%,50V	04222	MA205E104MAA
A9C1950	281-0766-00		CAP,FXD,CER DI:100PF,20%,200V	04222	MA106A101MAA
A9C1951	290-0269-01		CAP,FXD,ELCTLT:0.22UF,5%,35V,1KHZ,TANTULUM	56289	1730224X5035U
A9C1971	285-1236-00		CAP,FXD,PLASTIC:0.022UF,20%,400V	14752	23001E223M
A9C1972	290-0747-00		CAP,FXD,ELCTLT:100UF,+50-10%,25V	54473	ECE-825V100L
A9C1973	281-0826-00		CAP,FXD,CER DI:2200PF,5%,100V	20932	401EM100AD222K
A9C1980	281-0771-00		CAP,FXD,CER DI:2200PF,220%,200V	04222	MA106E222MAA
A9C1990	285-1096-00		CAP,FXD,PLASTIC:1UF,10%,50V	14752	230B1A105K
A9C1991	281-0826-00		CAP,FXD,CER DI:2200PF,5%,100V	20932	401EM100AD222K
A9CR1894	152-0400-00		SEMICOND DVC,DI:RECT,SI,400V,1A	04713	SR1977K
A9CR1895	152-0400-00		SEMICOND DVC,DI:RECT,SI,400V,1A	04713	SR1977K
A9CR1915	152-0061-00		SEMICOND DVC,DI:SM,SI,175V,0.1A,DO-35	07263	FDH2161
A9CR1930	152-0061-00		SEMICOND DVC,DI:SM,SI,175V,0.1A,DO-35	07263	FDH2161
A9CR1950	152-0061-00		SEMICOND DVC,DI:SM,SI,175V,0.1A,DO-35	07263	FDH2161

2445A Replaceable Electrical Parts
2445A/2455A Service

Component No.	Tektronix Part No.	Serial/Assembly No.		Name & Description	Mfr. Code	Mfr. Part No.
		Effective	Discont			
A9CR1953	152-0061-00			SEMICOND DVC,DI:SM,SI,175V,0.1A,00-35	07263	FDH2161
A9CR1990	152-0141-02			SEMICOND DVC,DI:SM,SI,30V,150MA,30V,00-35	03508	DA2527 (1N4152)
A9DS90	150-0030-00			LAMP,GLOW:60-90V MAX,0.7MA,A28-T,WIRE LEADS	58224	A28-T
A9DS91	150-0030-00			LAMP,GLOW:60-90V MAX,0.7MA,A28-T,WIRE LEADS	58224	A28-T
A9J901	131-0589-00			TERMINAL,PIN:0.46 L X 0.025 SQ PH BRZ (QUANTITY OF 9)	22526	48283-029
A9J902	131-0589-00			TERMINAL,PIN:0.46 L X 0.025 SQ PH BRZ (QUANTITY OF 2)	22526	48283-029
A9J903	131-0589-00			TERMINAL,PIN:0.46 L X 0.025 SQ PH BRZ (QUANTITY OF 2)	22526	48283-029
A9J904	131-0589-00			TERMINAL,PIN:0.46 L X 0.025 SQ PH BRZ	22526	48283-029
A9L1921	108-0262-00			COIL,RF:FIXED,510NH	80009	108-0262-00
A9L1974	108-0318-00			COIL,RF:FIXED,100UH	32159	81000H
A9P191	131-3461-00			HEADER,MICROCKT:14 PIN,0.5 L,GOLD PL	80009	131-3461-00
A9P900	-----			(SUBPART OF A9M900)		
A9Q1851	151-0443-00			TRANSISTOR:PMP,SI,TO-92	04713	SPS7950
A9Q1852	151-0443-00			TRANSISTOR:PMP,SI,TO-92	04713	SPS7950
A9Q1890	151-0443-00			TRANSISTOR:PMP,SI,TO-92	04713	SPS7950
A9Q1891	151-0745-00			TRANSISTOR:PMP,SI,TO-220	612771	2SA1077G
A9Q1880	151-0444-00			TRANSISTOR:NPN,SI,TO-92	04713	SPS797
A9R1812	315-0100-02			RES,FXD,CMPSM:10 OHM,5%,0.25M	01121	CB1005
A9R1813	315-0100-02			RES,FXD,CMPSM:10 OHM,5%,0.25M	01121	CB1005
A9R1833	315-0103-00	8010100	8010105	RES,FXD,FILM:10K OHM,5%,0.25M	19701	5043CX10K00J
A9R1833	313-1103-00	8010106		RES,FXD,FILM:10K OHM,5%,0.2M	57668	TR20JE10K0
A9R1834	315-0103-00	8010100	8010105	RES,FXD,FILM:10K OHM,5%,0.25M	19701	5043CX10K00J
A9R1834	313-1103-00	8010106		RES,FXD,FILM:10K OHM,5%,0.2M	57668	TR20JE10K0
A9R1842	311-2234-00			RES,VAR,NONMM:TRMR,5K OHM,20%,0.5M	TK1450	GF06UT 5K
A9R1848	311-2234-00			RES,VAR,NONMM:TRMR,5K OHM,20%,0.5M	TK1450	GF06UT 5K
A9R1853	321-0447-00			RES,FXD,FILM:442K OHM,1%,0.125M,TC=TO	24546	NA5504423F
A9R1854	321-0435-00			RES,FXD,FILM:332K OHM,1%,0.125M,TC=TO	07716	CEAD33202F
A9R1855	321-0407-00			RES,FXD,FILM:169K OHM,1%,0.125M,TC=TO	07716	CEAD16902F
A9R1856	321-0367-00			RES,FXD,FILM:64.9K OHM,1%,0.125M,TC=TO	07716	CEAD64901F
A9R1857	321-0364-00			RES,FXD,FILM:60.4K OHM,1%,0.125M,TC=TO	19701	5043ED60K40F
A9R1858	315-0105-00	8010100	8010105	RES,FXD,FILM:1M OHM,5%,0.25M	19701	5043CX1M000J
A9R1858	313-1105-00	8010106		RES,FXD,FILM:1M OHM,5%,0.2M	57668	TR20JE1M
A9R1864	311-2236-00			RES,VAR,NONMM:TRMR,20K OHM,20%,0.5M LINEAR	TK1450	GF06UT 20K
A9R1870	311-2239-00			RES,VAR,NONMM:TRMR,100K OHM,20%,0.5M LINEAR	TK1450	GF06UT 100K
A9R1871	315-0154-00			RES,FXD,FILM:150K OHM,5%,0.25M	57668	NTR25J-E150K
A9R1872	315-0184-00			RES,FXD,FILM:180K OHM,5%,0.25M	19701	5043CX180K0J
A9R1873	315-0103-00	8010100	8010105	RES,FXD,FILM:10K OHM,5%,0.25M	19701	5043CX10K00J
A9R1873	313-1103-00	8010106		RES,FXD,FILM:10K OHM,5%,0.2M	57668	TR20JE10K0
A9R1878	311-2239-00			RES,VAR,NONMM:TRMR,100K OHM,20%,0.5M LINEAR	TK1450	GF06UT 100K
A9R1880	315-0434-00			RES,FXD,FILM:430K OHM,5%,0.25M	57668	NTR25J-E430K
A9R1881	321-0385-00			RES,FXD,FILM:100K OHM,1%,0.125M,TC=TO	19701	5033ED100K0F
A9R1890	315-0473-00	8010100	8010105	RES,FXD,FILM:47K OHM,5%,0.25M	57668	NTR25J-E47K0
A9R1890	313-1473-00	8010106		RES,FXD,FILM:47K OHM,5%,0.2M	57668	TR20JE 47K
A9R1891	321-0481-04			RES,FXD,FILM:1M OHM,0.1%,0.125M,TC=T2	91637	CMF551160100038
A9R1892	321-0639-00			RES,FXD,FILM:9.6K OHM,1%,0.125M,TC=TO	19701	5043ED9K600F
A9R1892	321-0693-00			RES,FXD,FILM:68.1K OHM,0.5%,0.125M,TC=TO	19701	5033RD68120B2980
A9R1893	321-0481-04			RES,FXD,FILM:1M OHM,0.1%,0.125M,TC=T2	91637	CMF551160100038
A9R1895	315-0302-00	8010100	8010105	RES,FXD,FILM:3K OHM,5%,0.25M	57668	NTR25J-EB3K0
A9R1895	313-1302-00	8010106		RES,FXD,FILM:3K OHM,5%,0.2M	57668	TR20JE 03K0
A9R1896	315-0100-02			RES,FXD,CMPSM:10 OHM,5%,0.25M	01121	CB1005
A9R1897	315-0102-00	8010100	8010105	RES,FXD,FILM:1K OHM,5%,0.25M	57668	NTR25JED1K0
A9R1897	313-1102-00	8010106		RES,FXD,FILM:1K OHM,5%,0.2M	57668	TR20JED1K0
A9R1898	315-0102-00	8010100	8010105	RES,FXD,FILM:1K OHM,5%,0.25M	57668	NTR25JED1K0
A9R1898	313-1102-00	8010106		RES,FXD,FILM:1K OHM,5%,0.2M	57668	TR20JED1K0
A9R1901	315-0101-03			RES,FXD,CMPSM:100 OHM,5%,0.25M	01121	CB1015
A9R1910	321-0271-00			RES,FXD,FILM:6.49K OHM,1%,0.125M,TC=TO	07716	CEAD64900F

2445A Replaceable Electrical Parts
2445A/2455A Service

Component No.	Tektronix Part No.	Serial/Assembly No. Effective	Discont	Name & Description	Mfr. Code	Mfr. Part No.
A9R1911	321-0245-00			RES, FXD, FILM: 3.48K OHM, 1%, 0.125M, TC=TO	19701	5033ED3K48F
A9R1913	315-0101-03			RES, FXD, CMPSM: 100 OHM, 5%, 0.25M	01121	CB1015
A9R1920	315-0152-00			RES, FXD, FILM: 1.5K OHM, 5%, 0.25M	57668	NTR25J-E01K5
A9R1922	315-0331-03			RES, FXD, CMPSM: 330 OHM, 5%, 0.25M	01121	CB3315
A9R1941	315-0201-00	B010100	B010105	RES, FXD, FILM: 200 OHM, 5%, 0.25M	57668	NTR25J-E200E
A9R1941	313-1201-00	B010106		RES, FXD, FILM: 200 OHM, 5%, 0.2M	57668	TR20JE200E
A9R1944	321-0306-00			RES, FXD, FILM: 15.0K OHM, 1%, 0.125M, TC=TO	19701	5033ED15J00F
A9R1945	321-0963-07			RES, FXD, FILM: 98.73K OHM, 0.1%, 0.125M, TC=T9	07716	CEA 98.73K0HM 1%
A9R1950	315-0103-00	B010100	B010105	RES, FXD, FILM: 10K OHM, 5%, 0.25M	19701	5043CX10K00J
A9R1950	313-1103-00	B010106		RES, FXD, FILM: 10K OHM, 5%, 0.2M	57668	TR20JE10K0
A9R1951	315-0220-00	B010100	B010105	RES, FXD, FILM: 22 OHM, 5%, 0.25M	19701	5043CX22R00J
A9R1951	313-1220-00	B010106		RES, FXD, FILM: 22 OHM, 5%, 0.2M	57668	TR20JE22E
A9R1952	315-0202-00	B010100	B010105	RES, FXD, FILM: 2K OHM, 5%, 0.25M	57668	NTR25J-E 2K
A9R1952	313-1202-00	B010106		RES, FXD, FILM: 2K OHM, 5%, 0.2M	57668	TR20JE02K0
A9R1953	315-0393-00	B010100	B010105	RES, FXD, FILM: 39K OHM, 5%, 0.25M	57668	NTR25J-E39K0
A9R1953	313-1393-00	B010106		RES, FXD, FILM: 39K OHM, 5%, 0.2M	57668	TR20JE 39K
A9R1971	315-0202-00	B010100	B010105	RES, FXD, FILM: 2K OHM, 5%, 0.25M	57668	NTR25J-E 2K
A9R1971	313-1202-00	B010106		RES, FXD, FILM: 2K OHM, 5%, 0.2M	57668	TR20JE02K0
A9R1972	315-0224-00	B010100	B010105	RES, FXD, FILM: 220K OHM, 5%, 0.25M	57668	NTR25J-E220K
A9R1972	313-1224-00	B010106		RES, FXD, FILM: 220K OHM, 5%, 0.2M	57668	TR20JE 220K
A9R1973	315-0124-00	B010100	B010105	RES, FXD, FILM: 120K OHM, 5%, 0.25M	19701	5043CX120K0J
A9R1973	313-1124-00	B010106		RES, FXD, FILM: 120K OHM, 5%, 0.2M	57668	TR20JE120K
A9R1990	321-0693-00			RES, FXD, FILM: 68.1K OHM, 0.5%, 0.125M, TC=TO	19701	5033R06812082980
A9R1991	315-0107-00			RES, FXD, FILM: 100M OHM, 5%, 0.25M	01121	CB1075
A9R1992	315-0394-00	B010100	B010105	RES, FXD, FILM: 390K OHM, 5%, 0.25M	57668	NTR25J-E390K
A9R1992	313-1394-00	B010106		RES, FXD, FILM: 390K OHM, 5%, 0.2M	57668	TR20JE 390K
A9R1994	321-0402-00			RES, FXD, FILM: 150K OHM, 1%, 0.125M, TC=TO	19701	5033ED150K0F
A9T1970	120-1418-01			XFMR, PWR, SDN&SU: HIGH VOLTAGE	80009	120-1418-01
A9U1062	156-0411-02			MICROCKT, LINEAR: QUAD COMPARATOR, SCREENED	04713	LM339J05
A9U1830	152-0805-00			SEMICOND DVC, DI: HV MULT, 4.67KV IN, 14KV OUT	54431	MSR8506
A9U1890	156-1191-01			MICROCKT, LINEAR: DUAL BI-FET OP-AMP, 8 OIP	80009	156-1191-01
A9U1956	156-0158-07			MICROCKT, LINEAR: DUAL OPNL AMPL, SCREENED	01295	MC1458JG4
A9VR1891	152-0282-00			SEMICOND DVC, DI: ZEN, SI, 30V, 5%, 0.4M, DO-7	04713	SZG35009K13
A9W900	198-4603-01			WIRE SET, ELEC: W/CRT SOCKET	80009	198-4603-01
A9W1909	131-0566-00			BUS, COND: DUMMY RES, 0.094 OHM X 0.225L	24546	OWA 07
A14	670-8000-00			CIRCUIT BD ASSY: DYNAMIC CENTERING	80009	670-8000-00
A14C3401	281-0775-00			CAP, FXD, CER DI: 0.1UF, 20%, 50V	04222	MA205E104MAA
A14J141	131-0608-00			TERMINAL, PIN: 0.365 L X 0.025 BRZ GLD PL (QUANTITY OF 5)	22526	48283-036
A14R3401	311-1137-00			RES, VAR, NONHM: TRMR, 5K OHM, 0.5M	01121	E2C502
A14R3402	315-0222-00	B010100	B010105	RES, FXD, FILM: 2.2K OHM, 5%, 0.25M	57668	NTR25J-E02K2
A14R3402	313-1222-00	B010106		RES, FXD, FILM: 2.2K OHM, 5%, 0.2M	57668	TR20JE 02K2
A14R3403	315-0750-00	B010100	B010105	RES, FXD, FILM: 75 OHM, 5%, 0.25M	57668	NTR25J-E75E0
A14R3403	313-1750-00	B010106		RES, FXD, FILM: 75 OHM, 5%, 0.2M	57668	TR20JE 75E
A14R3404	321-0284-00			RES, FXD, FILM: 8.87K OHM, 1%, 0.125M, TC=TO	19701	5043ED8K870F
A14R3405	315-0750-00	B010100	B010105	RES, FXD, FILM: 75 OHM, 5%, 0.25M	57668	NTR25J-E75E0
A14R3405	313-1750-00	B010106		RES, FXD, FILM: 75 OHM, 5%, 0.2M	57668	TR20JE 75E
A14R3407	311-1137-00			RES, VAR, NONHM: TRMR, 5K OHM, 0.5M	01121	E2C502
A14R3408	321-0284-00			RES, FXD, FILM: 8.87K OHM, 1%, 0.125M, TC=TO	19701	5043ED8K870F
A14R3409	315-0222-00	B010100	B010105	RES, FXD, FILM: 2.2K OHM, 5%, 0.25M	57668	NTR25J-E02K2
A14R3409	313-1222-00	B010106		RES, FXD, FILM: 2.2K OHM, 5%, 0.2M	57668	TR20JE 02K2
A14R3410	315-0103-00	B010100	B010105	RES, FXD, FILM: 10K OHM, 5%, 0.25M	19701	5043CX10K00J
A14R3410	313-1103-00	B010106		RES, FXD, FILM: 10K OHM, 5%, 0.2M	57668	TR20JE10K0
A14R3411	315-0103-00	B010100	B010105	RES, FXD, FILM: 10K OHM, 5%, 0.25M	19701	5043CX10K00J
A14R3411	313-1103-00	B010106		RES, FXD, FILM: 10K OHM, 5%, 0.2M	57668	TR20JE10K0
A14U3401	156-0130-00			MICROCKT, LINEAR: MODULATOR/DEMODULATOR	80009	156-0130-00
A14U3402	156-0130-00			MICROCKT, LINEAR: MODULATOR/DEMODULATOR	80009	156-0130-00

2445A Replaceable Electrical Parts
 2445A/2455A Service

Component No.	Tektronix Part No.	Serial/Assembly No. Effective	Discont	Name & Description	Mfr. Code	Mfr. Part No.
A14VR3401	152-0227-00			SEMICOND DVC,DI:ZEN,SI,6.2V,5%,0.4M,00-7	04713	5Z13903
C10	281-0697-00			CAP,FXD,CER DI:5000PF,+100-0%,100V	72982	2425-003MSM0502Z
F90	159-0021-00			FUSE,CARTRIDGE:3AG,2A,250V,FAST BLOW	71400	AGC-CN-2
L90	119-1478-01			COIL,TUBE DEFL:FXD,TRACE ROTATION	80009	119-1478-01
S90	260-1967-00			SWITCH,SLIDE:DPOT 5A/250V 10A/125V MKD	TK0935	4021.0512
V900	154-0850-01			CRT ASSEMBLY:FINISHED 2445	80009	154-0850-01

REPLACEABLE ELECTRICAL PARTS

PARTS ORDERING INFORMATION

Replacement parts are available from or through your local Tektronix, Inc. Field Office or representative.

Changes to Tektronix instruments are sometimes made to accommodate improved components as they become available, and to give you the benefit of the latest circuit improvements developed in our engineering department. It is therefore important, when ordering parts, to include the following information in your order: Part number, instrument type or number, serial number, and modification number if applicable.

If a part you have ordered has been replaced with a new or improved part, your local Tektronix, Inc. Field Office or representative will contact you concerning any change in part number.

Change information, if any, is located at the rear of this manual.

LIST OF ASSEMBLIES

A list of assemblies can be found at the beginning of the Electrical Parts List. The assemblies are listed in numerical order. When the complete component number of a part is known, this list will identify the assembly in which the part is located.

CROSS INDEX-MFR. CODE NUMBER TO MANUFACTURER

The Mfr. Code Number to Manufacturer index for the Electrical Parts List is located immediately after this page. The Cross Index provides codes, names and addresses of manufacturers of components listed in the Electrical Parts List.

ABBREVIATIONS

Abbreviations conform to American National Standard Y1.1.

COMPONENT NUMBER (column one of the Electrical Parts List)

A numbering method has been used to identify assemblies, subassemblies and parts. Examples of this numbering method and typical expansions are illustrated by the following:

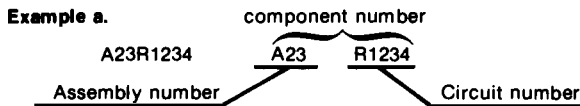

Read: Resistor 1234 of Assembly 23

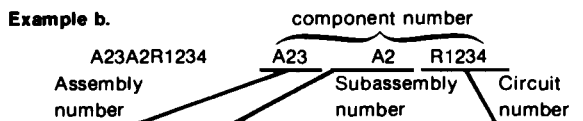

Read: Resistor 1234 of Subassembly 2 of Assembly 23

Only the circuit number will appear on the diagrams and circuit board illustrations. Each diagram and circuit board illustration is clearly marked with the assembly number. Assembly numbers are also marked on the mechanical exploded views located in the Mechanical Parts List. The component number is obtained by adding the assembly number prefix to the circuit number.

The Electrical Parts List is divided and arranged by assemblies in numerical sequence (e.g., assembly A1 with its subassemblies and parts, precedes assembly A2 with its subassemblies and parts).

Chassis-mounted parts have no assembly number prefix and are located at the end of the Electrical Parts List.

TEKTRONIX PART NO. (column two of the Electrical Parts List)

Indicates part number to be used when ordering replacement part from Tektronix.

SERIAL/MODEL NO. (columns three and four of the Electrical Parts List)

Column three (3) indicates the serial number at which the part was first used. Column four (4) indicates the serial number at which the part was removed. No serial number entered indicates part is good for all serial numbers.

NAME & DESCRIPTION (column five of the Electrical Parts List)

In the Parts List, an Item Name is separated from the description by a colon (:). Because of space limitations, an Item Name may sometimes appear as incomplete. For further Item Name identification, the U.S. Federal Cataloging Handbook H6-1 can be utilized where possible.

MFR. CODE (column six of the Electrical Parts List)

Indicates the code number of the actual manufacturer of the part. (Code to name and address cross reference can be found immediately after this page.)

MFR. PART NUMBER (column seven of the Electrical Parts List)

Indicates actual manufacturers part number.

CROSS INDEX - MFR. CODE NUMBER TO MANUFACTURER

Mfr. Code	Manufacturer	Address	City, State, Zip Code
00213	NYTRONICS COMPONENTS GROUP INC SUBSIDIARY OF NYTRONICS INC	ORANGE ST	DARLINGTON SC 29532
00779	AMP INC	P O BOX 3608	HARRISBURG PA 17105
01121	ALLEN-BRADLEY CO	1201 SOUTH 2ND ST	MILWAUKEE WI 53204
01295	TEXAS INSTRUMENTS INC SEMICONDUCTOR GROUP	13500 N CENTRAL EXPRESSWAY P O BOX 225012 M/S 49	DALLAS TX 75265
02113	CDILCRAFT INC	1102 SILVER LAKE RD	CARY IL 60013
02114	AMPEREX ELECTRONIC CORP FERROXCUBE DIV	5083 KINGS HWY	SAUGERTIES NY 12477
02735	RCA CORP SOLID STATE DIVISION	ROUTE 202	SOMERVILLE NJ 08876
03508	GENERAL ELECTRIC CO SEMI-CONDUCTOR PRODUCTS DEPT	M GENESEE ST	AUBURN NY 13021
04222	AVX CERAMICS DIV OF AVX CORP	19TH AVE SOUTH P O BOX 867	MYRTLE BEACH SC 29577
04713	MOTOROLA INC SEMICONDUCTOR GROUP	5005 E MCDOMELL RD	PHOENIX AZ 85008
05292	ITT COMPONENTS DIV		CLIFTON NJ
05397	UNION CARBIDE CORP MATERIALS SYSTEMS DIV	11901 MADISON AVE	CLEVELAND OH 44101
05828	GENERAL INSTRUMENT CORP GOVERNMENT SYSTEMS DIV	600 N JOHN ST	HICKSVILLE NY 11802
06665	PRECISION MONOLITHICS INC SUB OF BOURNS INC	1500 SPACE PARK DR	SANTA CLARA CA 95050
07263	FAIRCHILD CAMERA AND INSTRUMENT CORP SEMICONDUCTOR DIV	464 ELLIS ST	MOUNTAIN VIEW CA 94042
07716	TRM INC TRM ELECTRONICS COMPONENTS	2850 MT PLEASANT AVE	BURLINGTON IA 52601
09019	TRM INC FIXED RESISTORS/BURLINGTON GENERAL ELECTRIC CO SEMI-CONDUCTOR PRODUCTS DEPT OPERATIONAL PLANNING AND CUSTOMER ENGINEERING	ELECTRONICS PARK	SYRACUSE NY 13201
09353	C AND K COMPONENTS INC	15 RIVERDALE AVE	NENTON MA 02158
09922	BURNBY CORP	RICHARDS AVE	NORMALK CT 06852
11236	CTS OF BERNE INC	406 PARR ROAD	BERNE IN 46711
12954	MICROSEMI CORP	8700 E THOMAS RD P O BOX 1390	SCOTTSDALE AZ 85252
12969	UNITRODE CORP	580 PLEASANT ST	WATERTOWN MA 02172
14301	ANDERSON ELECTRONICS INC	310 PENN ST	HOLLIDAYSBURG PA 16648
14433	ITT SEMICONDUCTORS DIV		NEST PALM BEACH FL
14552	MICRO/SEMICONDUCTOR CORP	2830 S FAIRVIEW ST	SANTA ANA CA 92704
14752	ELECTRO CUBE INC	1710 S DEL MAR AVE	SAN GABRIEL CA 91776
15454	AMETEK INC RODAN DIV	2905 BLUE STAR ST	ANAHEIM CA 92806
18324	SIGNETICS CORP	811 E ARQUES	SUNNYVALE CA 94086
19701	MEPCO/ELECTRA INC A NORTH AMERICAN PHILIPS CO	P O BOX 760	MINERAL WELLS TX 76067
20462	PREM ENTERPRISES, INC.	3519 N. CHAPEL HILL	MCHENRY, IL 60050
20932	KYOCERA INC	11620 SORRENTO VALLEY RD	SAN DIEGO CA 92121
22526	DU PONT E I DE NEMOURS AND CO INC DU PONT CONNECTOR SYSTEMS	30 HUNTER LANE	CAMP HILL PA 17011
24546	CORNING GLASS WORKS	550 HIGH ST	BRADFORD PA 16701
25088	SIEMENS CORP	186 MOOD AVE S	ISELIN NJ 08830
27264	MOLEX INC CORPORATE HQ	2222 WELLINGTON COURT	LISLE IL 60532
31471	AMERICAN MICRO SYSTEMS INC	3800 HOMESTEAD RD	SANTA CLARA CA 95051
31918	ITT SCHADOM INC	8081 MALLACE RD	EDEN PRAIRIE MN 55343
32159	NEST-CAP ARIZONA	2201 E ELVIRA ROAD	TUCSON AZ 85706
32997	BOURNS INC TRIMPOT DIV	1200 COLUMBIA AVE	RIVERSIDE CA 92507
34335	ADVANCED MICRO DEVICES	901 THOMPSON PL	SUNNYVALE CA 94086
34479	RENCO CORP.	26 COROMAR DRIVE	GOLETA, CA 93117
50434	HEWLETT-PACKARD CO OPTOELECTRONICS DIV	640 PAGE HILL RD	PALO ALTO CA 94304
51406	MURATA ERIE NORTH AMERICA INC GEORGIA OPERATIONS	1148 FRANKLIN RD SE	MARIETTA GA 30067

CROSS INDEX - MFR. CODE NUMBER TO MANUFACTURER

Mfr. Code	Manufacturer	Address	City, State, Zip Code
52769	SPRAGUE-GOODMAN ELECTRONICS INC	134 FULTON AVE	GARDEN CITY PARK NY 11040
53387	MINNESOTA MINING AND MFG CO ELECTRONIC PRODUCTS DIV	3M CENTER	ST PAUL MN 55101
54473	MATSUSHITA ELECTRIC CORP OF AMERICA	ONE PANASONIC WAY	SECAUCUS NJ 07094
54583	TOK ELECTRONICS CORP	755 EASTGATE BLVD	GARDEN CITY NY 11530
54937	DEYOUNG MFG INC	1517 130TH AVE NE P O BOX 1806	BELLEVUE WA 98009
55112	WESTLAKE CAPACITORS INC	5334 STERLING CENTER DRIVE	WESTLAKE VILLAGE CA 91361
55680	NICHICON /AMERICA/ CORP	927 E STATE PKY	SCHAUMBURG IL 60195
56289	SPRAGUE ELECTRIC CO	87 MARSHALL ST	NORTH ADAMS MA 01247
57688	ROHM CORP	16931 HILLIKEN AVE	IRVINE CA 92713
58224	XENELL CORP	HWY 77 S P O BOX 726	MYNNEMOOD OK 73098
59660	TUSONIX INC	2155 N FORBES BLVD	TUCSON, ARIZONA 85705
59821	CENTRALAB INC	7158 MERCHANT AVE	EL PASO TX 79915
61271	SUB NORTH AMERICAN PHILIPS CORP		
71400	FUJITSU MICRO ELECTRONICS INC BUSSMANN MFG CO MCGRAM EDISON CO	3320 SCOTT BLVD 114 OLD STATE RD PO BOX 14460	SANTA CLARA CA 95051 ST LOUIS MO 63178
71744	GENERAL INSTRUMENT CORP LAMP DIV	4433 N RAVENSMOOD AVE	CHICAGO IL 60640
72982	ERIE TECHNOLOGICAL PRODUCTS INC	645 M 11TH ST	ERIE PA 16512
73138	BECKMAN INSTRUMENTS INC HELIPOT DIV	2500 HARBOR BLVD	FULLERTON CA 92634
75042	TRM INC TRM ELECTRONIC COMPONENTS	401 N BROAD ST	PHILADELPHIA PA 19108
80009	IRC FIXED RESISTORS PHILADELPHIA DIV TEKTRONIX INC	4900 S M GRIFFITH DR P O BOX 500	BEAVERTON OR 97077
81483	INTERNATIONAL RECTIFIER	9220 SUNSET BLVD P O BOX 2321 TERMINAL ANNEX	LOS ANGELES CA 90069
81855	EAGLE-PICHER INDUSTRIES INC ELECTRONICS DIV		
91637	DALE ELECTRONICS INC	P O BOX 609	COLUMBUS NE 68601
93410	HAMILTON STANDARD CONTROL ESSEX GROUP INC	45-55 PLYMOUTH ST P O BOX 1007	LEXINGTON OH 44904
54431	MURATA MFG CO LTD	16 KAIJEN NISHIJM CHO	NAGAOKAYO KYOTO JAPAN
TK0515	RIFA WORLD PRODUCTS INC	19678 8TH STREET EAST P O BOX 517	SONOMA CA 95476
TK0935	MARQUARDT SWITCHES INC	MARQUARDT 67 ALBANY ST	CAZENOVIA NY 13035
TK0946	SAN-O INDUSTRIAL CORP	170 MILBUR PL	BAHENTIA, LONG ISLAND NY 11716
TK0961	NEC ELECTRONICS USA INC	401 ELLIS ST	MOUNTAIN VIEW CA 94043
TK1015	MUSASHI WORKS OF HITACHI LTD	1450 JOSUJHON-CHO KODAIRA-SHI	TOKYO JAPAN
TK1345	ZHAN AND ASSOCIATES	7633 S 180TH	KENT WA 98032
TK1450	TOKYO COSMOS ELECTRIC CO LTD	2-268 SOBUDAI ZAMA	KANAGAMA 228 JAPAN
TK1544	COMPUTER CONNECTIONS	2427 PRATT AVE	HAYWARD CA 94544
TK1727	PHILIPS NEDERLAND BV AFD ELONCO	POSTBUS 90050	5600 PB EINDHOVEN THE NETHERLANDS
TK2042	ZHAN & ASSOCIATES	7633 SO. 180TH	KENT, WA 98032

2455A Replaceable Electrical Parts
2445A/2455A Service

Component No.	Tektronix Part No.	Serial/Assembly No. Effective Dscont	Name & Description	Mfr. Code	Mfr. Part No.
A1	670-9623-00		CIRCUIT BD ASSY:MAIN	80009	670-9623-00
A2	672-1037-11		CIRCUIT BD ASSY:LV PHR SPLY MODULE	80009	672-1037-11
A2A1	-----		CIRCUIT BD ASSY:REGULATOR (AVAILABLE AT THE 672-1037-XX LEVEL ONLY)		
A3	-----		CIRCUIT BD ASSY:INVERTER (AVAILABLE AT THE 672-1037-XX LEVEL ONLY)		
A4	670-9493-00		CIRCUIT BD ASSY:READOUT	80009	670-9493-00
A5	670-9052-00		CIRCUIT BD ASSY:DIGITAL CONTROL	80009	670-9052-00
A6	614-0448-00		FRONT PNL ASSY:STANDARD	80009	614-0448-00
A6A1	-----		CIRCUIT BD ASSY:SYNCHRONIZER		
A8	670-7280-00		CIRCUIT BD ASSY:SCALE ILLUM	80009	670-7280-00
A9	670-7277-08		CIRCUIT BD ASSY:HIGH VOLTAGE	80009	670-7277-08
A14	670-8000-00		CIRCUIT BD ASSY:DYNAMIC CENTERING	80009	670-8000-00
A1	670-9623-00		CIRCUIT BD ASSY:MAIN	80009	670-9623-00
A1A11	119-2342-01		ATTENUATOR,VAR:PRGM 1X-100X,100 STEPS,CH 1	80009	119-2342-01
A1A12	119-2342-02		ATTENUATOR,VAR:PRGM 1X-100X,100 STEPS,CH 2	80009	119-2342-02
A1C100	283-0000-00		CAP,FXD,CER 01:0.001UF,+100-0%,500V (COMBO WITH A1C200)	59660	831-610-Y5U0102P
A1C102	290-0973-00		CAP,FXD,ELCTLT:100UF,20%,25VDC	55680	ULB1E101NEA
A1C103	281-0812-00		CAP,FXD,CER 01:1000PF,10%,100V	04222	MA101C102KAA
A1C105	281-0064-00		CAP,VAR,PLASTIC:0.25-1.5PF,600V	52769	ER-530-013
A1C106	281-0775-01		CAP,FXD,CER 01:0.1UF,20%,50V	04222	MA205E104MAA
A1C107	290-0943-01		CAP,FXD,ELCTLT:47UF,20%,25V	55680	ULB1E470MPAANA1T
A1C108	281-0775-01		CAP,FXD,CER 01:0.1UF,20%,50V	04222	MA205E104MAA
A1C109	281-0909-00		CAP,FXD,CER 01:0.022UF,20%,50V	54583	MA12X7R1H223M-T
A1C110	281-0909-00		CAP,FXD,CER 01:0.022UF,20%,50V	54583	MA12X7R1H223M-T
A1C113	281-0909-00		CAP,FXD,CER 01:0.022UF,20%,50V	54583	MA12X7R1H223M-T
A1C114	290-0943-01		CAP,FXD,ELCTLT:47UF,20%,25V	55680	ULB1E470MPAANA1T
A1C115	281-0761-00		CAP,FXD,CER 01:27PF,5%,100V	04222	MA101A270JAA
A1C116	281-0814-00		CAP,FXD,CER 01:100 PF,10%,100V	04222	MA101A101KAA
A1C117	281-0775-01		CAP,FXD,CER 01:0.1UF,20%,50V	04222	MA205E104MAA
A1C118	281-0205-00		CAP,VAR,PLASTIC:5.5-65 PF,100V	TK1727	2222-808-32659
A1C119	281-0909-00		CAP,FXD,CER 01:0.022UF,20%,50V	54583	MA12X7R1H223M-T
A1C120	281-0909-00		CAP,FXD,CER 01:0.022UF,20%,50V	54583	MA12X7R1H223M-T
A1C121	290-0943-01		CAP,FXD,ELCTLT:47UF,20%,25V	55680	ULB1E470MPAANA1T
A1C125	281-0775-01		CAP,FXD,CER 01:0.1UF,20%,50V	04222	MA205E104MAA
A1C130	290-0776-00		CAP,FXD,ELCTLT:22UF,+50-10 %,10V	55680	ULA1A220TEA
A1C152	281-0909-00		CAP,FXD,CER 01:0.022UF,20%,50V	54583	MA12X7R1H223M-T
A1C154	281-0812-00		CAP,FXD,CER 01:1000PF,10%,100V	04222	MA101C102KAA
A1C171	281-0851-00		CAP,FXD,CER 01:180PF,5%,100VDC	04222	MA101A181JAA
A1C175	285-1301-01		CAP,FXD,MTLZO:0.47UF,10%,50V	55112	1850.47K50A88
A1C176	285-1348-00		CAP,FXD,MTLZO:0.22UF,10%,63V	55112	1850.22K63A88
A1C177	285-1348-00		CAP,FXD,MTLZO:0.22UF,10%,63V	55112	1850.22K63A88
A1C179	285-1301-01		CAP,FXD,MTLZO:0.47UF,10%,50V	55112	1850.47K50A88
A1C180	285-1348-00		CAP,FXD,MTLZO:0.22UF,10%,63V	55112	1850.22K63A88
A1C181	285-1348-00		CAP,FXD,MTLZO:0.22UF,10%,63V	55112	1850.22K63A88
A1C182	285-1348-00		CAP,FXD,MTLZO:0.22UF,10%,63V	55112	1850.22K63A88
A1C183	285-1348-00		CAP,FXD,MTLZO:0.22UF,10%,63V	55112	1850.22K63A88
A1C184	281-0775-01		CAP,FXD,CER 01:0.1UF,20%,50V	04222	MA205E104MAA
A1C185	290-0943-01		CAP,FXD,ELCTLT:47UF,20%,25V	55680	ULB1E470MPAANA1T
A1C200	283-0000-00		CAP,FXD,CER 01:0.001UF,+100-0%,500V (COMBO WITH A1C100)	59660	831-610-Y5U0102P
A1C202	281-0812-00		CAP,FXD,CER 01:1000PF,10%,100V	04222	MA101C102KAA
A1C203	281-0773-00		CAP,FXD,CER 01:0.01UF,10%,100V	04222	MA201C103KAA
A1C205	281-0064-00		CAP,VAR,PLASTIC:0.25-1.5PF,600V	52769	ER-530-013
A1C207	281-0909-00		CAP,FXD,CER 01:0.022UF,20%,50V	54583	MA12X7R1H223M-T
A1C209	281-0909-00		CAP,FXD,CER 01:0.022UF,20%,50V	54583	MA12X7R1H223M-T
A1C210	281-0909-00		CAP,FXD,CER 01:0.022UF,20%,50V	54583	MA12X7R1H223M-T

Component No.	Tektronix Part No.	Serial/Assembly No. Effective Dscont	Name & Description	Mfr. Code	Mfr. Part No.
A1C211	281-0909-00		CAP, FXD, CER DI:0.022UF, 20%, 50V	54583	MA12X7R1H223M-T
A1C217	281-0775-01		CAP, FXD, CER DI:0.1UF, 20%, 50V	04222	MA205E104MAA
A1C218	290-0943-01		CAP, FXD, ELCTLT:47UF, 20%, 25V	55680	ULB1E470MPAANA1T
A1C219	281-0775-01		CAP, FXD, CER DI:0.1UF, 20%, 50V	04222	MA205E104MAA
A1C220	281-0775-01		CAP, FXD, CER DI:0.1UF, 20%, 50V	04222	MA205E104MAA
A1C221	290-0943-01		CAP, FXD, ELCTLT:47UF, 20%, 25V	55680	ULB1E470MPAANA1T
A1C223	281-0812-00		CAP, FXD, CER DI:1000PF, 10%, 100V	04222	MA101C102KAA
A1C225	281-0775-01		CAP, FXD, CER DI:0.1UF, 20%, 50V	04222	MA205E104MAA
A1C301	281-0775-01		CAP, FXD, CER DI:0.1UF, 20%, 50V	04222	MA205E104MAA
A1C302	281-0775-01		CAP, FXD, CER DI:0.1UF, 20%, 50V	04222	MA205E104MAA
A1C307	290-0943-01		CAP, FXD, ELCTLT:47UF, 20%, 25V	55680	ULB1E470MPAANA1T
A1C310	281-0909-00		CAP, FXD, CER DI:0.022UF, 20%, 50V	54583	MA12X7R1H223M-T
A1C311	281-0909-00		CAP, FXD, CER DI:0.022UF, 20%, 50V	54583	MA12X7R1H223M-T
A1C325	290-0943-01		CAP, FXD, ELCTLT:47UF, 20%, 25V	55680	ULB1E470MPAANA1T
A1C329	281-0773-00		CAP, FXD, CER DI:0.01UF, 10%, 100V	04222	MA201C103KAA
A1C332	281-0773-00		CAP, FXD, CER DI:0.01UF, 10%, 100V	04222	MA201C103KAA
A1C336	290-0943-01		CAP, FXD, ELCTLT:47UF, 20%, 25V	55680	ULB1E470MPAANA1T
A1C351	281-0909-00		CAP, FXD, CER DI:0.022UF, 20%, 50V	54583	MA12X7R1H223M-T
A1C402	281-0762-00		CAP, FXD, CER DI:27PF, 20%, 100V	04222	MA101A270MAA
A1C403	281-0218-00		CAP, VAR, CER DI:1-5PF, +2 -2.5%, 100V	59660	513-011A1-5
A1C404	281-0218-00		CAP, VAR, CER DI:1-5PF, +2 -2.5%, 100V	59660	513-011A1-5
A1C412	281-0762-00		CAP, FXD, CER DI:27PF, 20%, 100V	04222	MA101A270MAA
A1C415	281-0909-00		CAP, FXD, CER DI:0.022UF, 20%, 50V	54583	MA12X7R1H223M-T
A1C458	281-0909-00		CAP, FXD, CER DI:0.022UF, 20%, 50V	54583	MA12X7R1H223M-T
A1C460	281-0909-00		CAP, FXD, CER DI:0.022UF, 20%, 50V	54583	MA12X7R1H223M-T
A1C464	281-0763-00		CAP, FXD, CER DI:47PF, 10%, 100V	04222	MA101A470KAA
A1C466	281-0763-00		CAP, FXD, CER DI:47PF, 10%, 100V	04222	MA101A470KAA
A1C478	281-0759-00		CAP, FXD, CER DI:22PF, 10%, 100V	04222	MA101A220KAA
A1C480	281-0775-01		CAP, FXD, CER DI:0.1UF, 20%, 50V	04222	MA205E104MAA
A1C487	281-0823-00		CAP, FXD, CER DI:470PF, 10%, 50V	04222	MA105A471KAA
A1C488	281-0814-00		CAP, FXD, CER DI:100 PF, 10%, 100V	04222	MA101A101KAA
A1C500	281-0909-00		CAP, FXD, CER DI:0.022UF, 20%, 50V	54583	MA12X7R1H223M-T
A1C501	281-0909-00		CAP, FXD, CER DI:0.022UF, 20%, 50V	54583	MA12X7R1H223M-T
A1C512	290-0246-00		CAP, FXD, ELCTLT:3.3UF, 10%, 15V	12954	D3R3EA15K1
A1C513	285-1301-01		CAP, FXD, WTLZD:0.47UF, 10%, 50V	55112	1850.47K50ABB
A1C520	281-0814-00		CAP, FXD, CER DI:100 PF, 10%, 100V	04222	MA101A101KAA
A1C521	281-0909-00		CAP, FXD, CER DI:0.022UF, 20%, 50V	54583	MA12X7R1H223M-T
A1C528	281-0775-01		CAP, FXD, CER DI:0.1UF, 20%, 50V	04222	MA205E104MAA
A1C536	290-0246-00		CAP, FXD, ELCTLT:3.3UF, 10%, 15V	12954	D3R3EA15K1
A1C537	281-0812-00		CAP, FXD, CER DI:1000PF, 10%, 100V	04222	MA101C102KAA
A1C544	281-0814-00		CAP, FXD, CER DI:100 PF, 10%, 100V	04222	MA101A101KAA
A1C601	281-0270-00		CAP, VAR, CER DI:9-90PF, 50V	51406	T703R900E
A1C617	281-0773-00		CAP, FXD, CER DI:0.01UF, 10%, 100V	04222	MA201C103KAA
A1C625	281-0909-00		CAP, FXD, CER DI:0.022UF, 20%, 50V	54583	MA12X7R1H223M-T
A1C645	281-0773-00		CAP, FXD, CER DI:0.01UF, 10%, 100V	04222	MA201C103KAA
A1C650	281-0823-00		CAP, FXD, CER DI:470PF, 10%, 50V	04222	MA105A471KAA
A1C653	281-0819-00		CAP, FXD, CER DI:33 PF, 5%, 50V	04222	GC105A330J
A1C669	281-0775-01		CAP, FXD, CER DI:0.1UF, 20%, 50V	04222	MA205E104MAA
A1C675	281-0775-01		CAP, FXD, CER DI:0.1UF, 20%, 50V	04222	MA205E104MAA
A1C707	281-0808-00		CAP, FXD, CER DI:7 PF, 20%, 100V	04222	MA101A7R04AA
A1C708	285-0676-01		CAP, FXD, PLASTIC:0.1UF, 3, 5%, 35V	80009	285-0676-01
A1C709	285-1060-00		CAP, FXD, PLASTIC:10UF, 3%, 25V	80009	285-1060-00
A1C710	281-0775-01		CAP, FXD, CER DI:0.1UF, 20%, 50V	04222	MA205E104MAA
A1C712	285-1301-01		CAP, FXD, WTLZD:0.47UF, 10%, 50V	55112	1850.47K50ABB
A1C722	281-0909-00		CAP, FXD, CER DI:0.022UF, 20%, 50V	54583	MA12X7R1H223M-T
A1C723	290-0943-01		CAP, FXD, ELCTLT:47UF, 20%, 25V	55680	ULB1E470MPAANA1T
A1C730	281-0909-00		CAP, FXD, CER DI:0.022UF, 20%, 50V	54583	MA12X7R1H223M-T
A1C731	290-0944-00		CAP, FXD, ELCTLT:220UF, +50-10%, 10V	55680	ULB1A221TPAANA
A1C732	290-0944-00		CAP, FXD, ELCTLT:220UF, +50-10%, 10V	55680	ULB1A221TPAANA

2455A Replaceable Electrical Parts
2445A/2455A Service

Component No.	Tektronix Part No.	Serial/Assembly No. Effective Dscont	Name & Description	Mfr. Code	Mfr. Part No.
A1C733	290-0943-01		CAP,FXD,ELCTLT:47UF,20%,25V	55680	ULB1E470MPAANA1T
A1C735	281-0823-00		CAP,FXD,CER DI:470PF,10%,50V	04222	MA105A471KAA
A1C738	290-0943-01		CAP,FXD,ELCTLT:47UF,20%,25V	55680	ULB1E470MPAANA1T
A1C740	290-0943-01		CAP,FXD,ELCTLT:47UF,20%,25V	55680	ULB1E470MPAANA1T
A1C742	281-0812-00		CAP,FXD,CER DI:1000PF,10%,100V	04222	MA101C102KAA
A1C803	281-0909-00		CAP,FXD,CER DI:0.022UF,20%,50V	54583	MA12X7R1H223M-T
A1C804	281-0797-00		CAP,FXD,CER DI:15PF,10%,100V	04222	MA106A150KAA
A1C805	281-0823-00		CAP,FXD,CER DI:470PF,10%,50V	04222	MA105A471KAA
A1C806	283-0156-00		CAP,FXD,CER DI:0.001UF,+80-20%,200V	05397	C315C102Z2R5CA
A1C808	281-0757-00		CAP,FXD,CER DI:10PF,20%,100V	04222	MA101A100MAA
A1C809	281-0819-00		CAP,FXD,CER DI:33PF,5%,50V	04222	GC105A330J
A1C810	281-0909-00		CAP,FXD,CER DI:0.022UF,20%,50V	54583	MA12X7R1H223M-T
A1C811	281-0909-00		CAP,FXD,CER DI:0.022UF,20%,50V	54583	MA12X7R1H223M-T
A1C817	281-0812-00		CAP,FXD,CER DI:1000PF,10%,100V	04222	MA101C102KAA
A1C819	281-0909-00		CAP,FXD,CER DI:0.022UF,20%,50V	54583	MA12X7R1H223M-T
A1C822	281-0775-01		CAP,FXD,CER DI:0.1UF,20%,50V	04222	MA205E104MAA
A1C823	281-0909-00		CAP,FXD,CER DI:0.022UF,20%,50V	54583	MA12X7R1H223M-T
A1C830	281-0812-00		CAP,FXD,CER DI:1000PF,10%,100V	04222	MA101C102KAA
A1C848	281-0909-00		CAP,FXD,CER DI:0.022UF,20%,50V	54583	MA12X7R1H223M-T
A1C849	281-0775-01		CAP,FXD,CER DI:0.1UF,20%,50V	04222	MA205E104MAA
A1C850	281-0909-00		CAP,FXD,CER DI:0.022UF,20%,50V	54583	MA12X7R1H223M-T
A1C851	285-1301-01		CAP,FXD,MTLZO:0.47UF,10%,50V	55112	1850.47K50A8B
A1C852	285-1301-01		CAP,FXD,MTLZO:0.47UF,10%,50V	55112	1850.47K50A8B
A1C853	285-1301-01		CAP,FXD,MTLZO:0.47UF,10%,50V	55112	1850.47K50A8B
A1C854	285-1301-01		CAP,FXD,MTLZO:0.47UF,10%,50V	55112	1850.47K50A8B
A1C903	281-0909-00		CAP,FXD,CER DI:0.022UF,20%,50V	54583	MA12X7R1H223M-T
A1C907	281-0808-00		CAP,FXD,CER DI:7PF,20%,100V	04222	MA101A7R04AA
A1C908	285-0752-03		CAP,FXD,PLASTIC:1UF,3%,50V	80009	285-0752-03
A1C912	281-0909-00		CAP,FXD,CER DI:0.022UF,20%,50V	54583	MA12X7R1H223M-T
A1C933	281-0909-00		CAP,FXD,CER DI:0.022UF,20%,50V	54583	MA12X7R1H223M-T
A1C938	281-0909-00		CAP,FXD,CER DI:0.022UF,20%,50V	54583	MA12X7R1H223M-T
A1C940	281-0909-00		CAP,FXD,CER DI:0.022UF,20%,50V	54583	MA12X7R1H223M-T
A1C941	281-0763-00		CAP,FXD,CER DI:47PF,10%,100V	04222	MA101A470KAA
A1C943	281-0909-00		CAP,FXD,CER DI:0.022UF,20%,50V	54583	MA12X7R1H223M-T
A1C947	281-0759-00		CAP,FXD,CER DI:22PF,10%,100V	04222	MA101A220KAA
A1C957	290-0804-00		CAP,FXD,ELCTLT:10UF,+50-10%,25V	55680	ULA1E100TEA
A1C958	281-0909-00		CAP,FXD,CER DI:0.022UF,20%,50V	54583	MA12X7R1H223M-T
A1C966	281-0783-00		CAP,FXD,CER DI:0.1UF,20%,100V	04222	MA401C104MAA
A1C967	281-0783-00		CAP,FXD,CER DI:0.1UF,20%,100V	04222	MA401C104MAA
A1C972	281-0756-00		CAP,FXD,CER DI:2.2PF,+/-0.5PF,200V	04222	MA106A2R20AA
A1C973	281-0909-00		CAP,FXD,CER DI:0.022UF,20%,50V	54583	MA12X7R1H223M-T
A1C975	281-0775-01		CAP,FXD,CER DI:0.1UF,20%,50V	04222	MA205E104MAA
A1C980	281-0909-00		CAP,FXD,CER DI:0.022UF,20%,50V	54583	MA12X7R1H223M-T
A1C982	281-0759-00		CAP,FXD,CER DI:22PF,10%,100V	04222	MA101A220KAA
A1C988	281-0909-00		CAP,FXD,CER DI:0.022UF,20%,50V	54583	MA12X7R1H223M-T
A1C990	281-0909-00		CAP,FXD,CER DI:0.022UF,20%,50V	54583	MA12X7R1H223M-T
A1C995	281-0810-00		CAP,FXD,CER DI:5.6PF,+/-0.5PF,100V	04222	MA101A5R60AA
A1CR100	152-0323-01		SEMICONO OVC,DI:SM,SI,35V,0.1A,DO-35	14552	MT5127
A1CR101	152-0323-01		SEMICONO OVC,DI:SM,SI,35V,0.1A,DO-35	14552	MT5127
A1CR107	152-0066-00		SEMICONO OVC,DI:RECT,SI,400V,1A,DO-41	05828	GP10G-020
A1CR130	152-0141-02		SEMICONO OVC,DI:SM,SI,30V,150MA,30V,DO-35	03508	0A2527 (1M4152)
A1CR131	152-0141-02		SEMICONO OVC,DI:SM,SI,30V,150MA,30V,DO-35	03508	0A2527 (1M4152)
A1CR140	152-0141-02		SEMICONO OVC,DI:SM,SI,30V,150MA,30V,DO-35	03508	0A2527 (1M4152)
A1CR141	152-0141-02		SEMICONO OVC,DI:SM,SI,30V,150MA,30V,DO-35	03508	0A2527 (1M4152)
A1CR142	152-0141-02		SEMICONO OVC,DI:SM,SI,30V,150MA,30V,DO-35	03508	0A2527 (1M4152)
A1CR143	152-0141-02		SEMICONO OVC,DI:SM,SI,30V,150MA,30V,DO-35	03508	0A2527 (1M4152)
A1CR144	152-0141-02		SEMICONO OVC,DI:SM,SI,30V,150MA,30V,DO-35	03508	0A2527 (1M4152)
A1CR145	152-0141-02		SEMICONO OVC,DI:SM,SI,30V,150MA,30V,DO-35	03508	0A2527 (1M4152)
A1CR146	152-0141-02		SEMICONO OVC,DI:SM,SI,30V,150MA,30V,DO-35	03508	0A2527 (1M4152)

2455A Replaceable Electrical Parts
2445A/2455A Service

Component No.	Tektronix Part No.	Serial/Assembly No. Effective Dscont	Name & Description	Mfr. Code	Mfr. Part No.
A1CR147	152-0141-02		SEMICOND DVC,DI:SM,SI,30V,150MA,30V,00-35	03508	0A2527 (1N4152)
A1CR148	152-0141-02		SEMICOND DVC,DI:SM,SI,30V,150MA,30V,00-35	03508	0A2527 (1N4152)
A1CR149	152-0141-02		SEMICOND DVC,DI:SM,SI,30V,150MA,30V,00-35	03508	0A2527 (1N4152)
A1CR150	152-0141-02		SEMICOND DVC,DI:SM,SI,30V,150MA,30V,00-35	03508	0A2527 (1N4152)
A1CR151	152-0141-02		SEMICOND DVC,DI:SM,SI,30V,150MA,30V,00-35	03508	0A2527 (1N4152)
A1CR152	152-0141-02		SEMICOND DVC,DI:SM,SI,30V,150MA,30V,00-35	03508	0A2527 (1N4152)
A1CR153	152-0141-02		SEMICOND DVC,DI:SM,SI,30V,150MA,30V,00-35	03508	0A2527 (1N4152)
A1CR154	152-0141-02		SEMICOND DVC,DI:SM,SI,30V,150MA,30V,00-35	03508	0A2527 (1N4152)
A1CR155	152-0141-02		SEMICOND DVC,DI:SM,SI,30V,150MA,30V,00-35	03508	0A2527 (1N4152)
A1CR161	152-0141-02		SEMICOND DVC,DI:SM,SI,30V,150MA,30V,00-35	03508	0A2527 (1N4152)
A1CR162	152-0141-02		SEMICOND DVC,DI:SM,SI,30V,150MA,30V,00-35	03508	0A2527 (1N4152)
A1CR163	152-0141-02		SEMICOND DVC,DI:SM,SI,30V,150MA,30V,00-35	03508	0A2527 (1N4152)
A1CR180	152-0141-02		SEMICOND DVC,DI:SM,SI,30V,150MA,30V,00-35	03508	0A2527 (1N4152)
A1CR181	152-0141-02		SEMICOND DVC,DI:SM,SI,30V,150MA,30V,00-35	03508	0A2527 (1N4152)
A1CR200	152-0323-01		SEMICOND DVC,DI:SM,SI,35V,0.1A,00-35	14552	MT5127
A1CR201	152-0323-01		SEMICOND DVC,DI:SM,SI,35V,0.1A,00-35	14552	MT5127
A1CR354	152-0141-02		SEMICOND DVC,DI:SM,SI,30V,150MA,30V,00-35	03508	0A2527 (1N4152)
A1CR360	152-0141-02		SEMICOND DVC,DI:SM,SI,30V,150MA,30V,00-35	03508	0A2527 (1N4152)
A1CR460	152-0141-02		SEMICOND DVC,DI:SM,SI,30V,150MA,30V,00-35	03508	0A2527 (1N4152)
A1CR461	152-0141-02		SEMICOND DVC,DI:SM,SI,30V,150MA,30V,00-35	03508	0A2527 (1N4152)
A1CR476	152-0141-02		SEMICOND DVC,DI:SM,SI,30V,150MA,30V,00-35	03508	0A2527 (1N4152)
A1CR484	152-0141-02		SEMICOND DVC,DI:SM,SI,30V,150MA,30V,00-35	03508	0A2527 (1N4152)
A1CR485	152-0141-02		SEMICOND DVC,DI:SM,SI,30V,150MA,30V,00-35	03508	0A2527 (1N4152)
A1CR495	152-0141-02		SEMICOND DVC,DI:SM,SI,30V,150MA,30V,00-35	03508	0A2527 (1N4152)
A1CR503	152-0141-02		SEMICOND DVC,DI:SM,SI,30V,150MA,30V,00-35	03508	0A2527 (1N4152)
A1CR538	152-0141-02		SEMICOND DVC,DI:SM,SI,30V,150MA,30V,00-35	03508	0A2527 (1N4152)
A1CR539	152-0141-02		SEMICOND DVC,DI:SM,SI,30V,150MA,30V,00-35	03508	0A2527 (1N4152)
A1CR600	152-0141-02		SEMICOND DVC,DI:SM,SI,30V,150MA,30V,00-35	03508	0A2527 (1N4152)
A1CR601	152-0141-02		SEMICOND DVC,DI:SM,SI,30V,150MA,30V,00-35	03508	0A2527 (1N4152)
A1CR616	152-0141-02		SEMICOND DVC,DI:SM,SI,30V,150MA,30V,00-35	03508	0A2527 (1N4152)
A1CR619	152-0141-02		SEMICOND DVC,DI:SM,SI,30V,150MA,30V,00-35	03508	0A2527 (1N4152)
A1CR620	152-0141-02		SEMICOND DVC,DI:SM,SI,30V,150MA,30V,00-35	03508	0A2527 (1N4152)
A1CR621	152-0141-02		SEMICOND DVC,DI:SM,SI,30V,150MA,30V,00-35	03508	0A2527 (1N4152)
A1CR652	152-0141-02		SEMICOND DVC,DI:SM,SI,30V,150MA,30V,00-35	03508	0A2527 (1N4152)
A1CR653	152-0141-02		SEMICOND DVC,DI:SM,SI,30V,150MA,30V,00-35	03508	0A2527 (1N4152)
A1CR707	152-0141-02		SEMICOND DVC,DI:SM,SI,30V,150MA,30V,00-35	03508	0A2527 (1N4152)
A1CR741	152-0141-02		SEMICOND DVC,DI:SM,SI,30V,150MA,30V,00-35	03508	0A2527 (1N4152)
A1CR746	152-0141-02		SEMICOND DVC,DI:SM,SI,30V,150MA,30V,00-35	03508	0A2527 (1N4152)
A1CR747	152-0141-02		SEMICOND DVC,DI:SM,SI,30V,150MA,30V,00-35	03508	0A2527 (1N4152)
A1CR752	152-0075-00		SEMICOND DVC,DI:SM,GE,22V,80MM,00-7	14433	G866
A1CR807	152-0574-00		SEMICOND DVC,DI:SM,SI,120V,0.15A,00-35	12969	NDP566
A1CR811	152-0141-02		SEMICOND DVC,DI:SM,SI,30V,150MA,30V,00-35	03508	0A2527 (1N4152)
A1CR850	152-0141-02		SEMICOND DVC,DI:SM,SI,30V,150MA,30V,00-35	03508	0A2527 (1N4152)
A1CR950	152-0141-02		SEMICOND DVC,DI:SM,SI,30V,150MA,30V,00-35	03508	0A2527 (1N4152)
A1CR951	152-0141-02		SEMICOND DVC,DI:SM,SI,30V,150MA,30V,00-35	03508	0A2527 (1N4152)
A1CR956	152-0141-02		SEMICOND DVC,DI:SM,SI,30V,150MA,30V,00-35	03508	0A2527 (1N4152)
A1CR966	152-0574-00		SEMICOND DVC,DI:SM,SI,120V,0.15A,00-35	12969	NDP566
A1CR972	152-0574-00		SEMICOND DVC,DI:SM,SI,120V,0.15A,00-35	12969	NDP566
A1CR982	152-0141-02		SEMICOND DVC,DI:SM,SI,30V,150MA,30V,00-35	03508	0A2527 (1N4152)
A1CR987	152-0574-00		SEMICOND DVC,DI:SM,SI,120V,0.15A,00-35	12969	NDP566
A1DL100	119-1490-01		DELAY LINE,ELEC:73NS,150 OHM	80009	119-1490-01
A1E940	276-0507-00		SHLD BEAD,ELEK:FERRITE	02114	56-590-658/38
A1E960	276-0507-00		SHLD BEAD,ELEK:FERRITE	02114	56-590-658/38
A1J9	131-0608-00		TERMINAL,PIN:0.365 L X 0.025 BRZ GLD PL	22526	48283-036
A1J10	131-0608-00		TERMINAL,PIN:0.365 L X 0.025 BRZ GLD PL (QUANTITY OF 3)	22526	48283-036
A1J11	131-0608-00		TERMINAL,PIN:0.365 L X 0.025 BRZ GLD PL (QUANTITY OF 3)	22526	48283-036
A1J100	131-0608-00		TERMINAL,PIN:0.365 L X 0.025 BRZ GLD PL	22526	48283-036

2455A Replaceable Electrical Parts
2445A/2455A Service

Component No.	Tektronix Part No.	Serial/Assembly No. Effective Dscont	Name & Description	Mfr. Code	Mfr. Part No.
			(QUANTITY OF 2)		
A1J101	131-3520-00		CONN,RCPT,ELEC:HDR,10 CONT,STR SLDR PIN	53387	3591-6002
A1J102	131-3520-00		CONN,RCPT,ELEC:HDR,10 CONT,STR SLDR PIN	53387	3591-6002
A1J103	131-0608-00		TERMINAL,PIN:0.365 L X 0.025 BRZ GLD PL	22526	48283-036
			(QUANTITY OF 2)		
A1J104	131-0608-00		TERMINAL,PIN:0.365 L X 0.025 BRZ GLD PL	22526	48283-036
			(QUANTITY OF 4)		
A1J105	131-0608-00		TERMINAL,PIN:0.365 L X 0.025 BRZ GLD PL	22526	48283-036
			(QUANTITY OF 2)		
A1J109	131-0608-00		TERMINAL,PIN:0.365 L X 0.025 BRZ GLD PL	22526	48283-036
			(QUANTITY OF 2)		
A1J117	131-0608-00		TERMINAL,PIN:0.365 L X 0.025 BRZ GLD PL	22526	48283-036
A1J120	131-3152-00		CONN,RCPT,ELEC:HEADER,2 X 8 0.1 SPACING	22526	75867-003
A1J181	131-0608-00		TERMINAL,PIN:0.365 L X 0.025 BRZ GLD PL	22526	48283-036
			(QUANTITY OF 2)		
A1J411	131-3362-00		CONN,RCPT,ELEC:HEADER,STR,26 PIN	53387	3593-6002
A1J511	131-3362-00		CONN,RCPT,ELEC:HEADER,STR,26 PIN	53387	3593-6002
A1J512	131-3364-00		CONN,RCPT,ELEC:HEADER,STRAIGHT,34 PIN	53387	3594-6002
A1L101	108-1251-00		COIL,RF:FXD,2.7UH,10%	54583	SPT 0406-2R7K-6
A1L107	108-1251-00		COIL,RF:FXD,2.7UH,10%	54583	SPT 0406-2R7K-6
A1L113	108-1251-00		COIL,RF:FXD,2.7UH,10%	54583	SPT 0406-2R7K-6
A1L115	108-0317-00		COIL,RF:FIXED,15 UH	32159	71501M+10PERCENT
A1L120	108-1251-00		COIL,RF:FXD,2.7UH,10%	54583	SPT 0406-2R7K-6
A1L219	108-1251-00		COIL,RF:FXD,2.7UH,10%	54583	SPT 0406-2R7K-6
A1L220	108-1251-00		COIL,RF:FXD,2.7UH,10%	54583	SPT 0406-2R7K-6
A1L307	108-1251-00		COIL,RF:FXD,2.7UH,10%	54583	SPT 0406-2R7K-6
A1L325	108-1251-00		COIL,RF:FXD,2.7UH,10%	54583	SPT 0406-2R7K-6
A1L336	108-1251-00		COIL,RF:FXD,2.7UH,10%	54583	SPT 0406-2R7K-6
A1L521	108-1251-00		COIL,RF:FXD,2.7UH,10%	54583	SPT 0406-2R7K-6
A1L605	108-0170-01		COIL,RF:FIXED,360NH	TK2042	ORDER BY DESCR
A1L606	108-0736-00		COIL,RF:FIXED,810NH	TK2042	ORDER BY DESCR
A1L607	108-0736-00		COIL,RF:FIXED,810NH	TK2042	ORDER BY DESCR
A1L608	108-0170-01		COIL,RF:FIXED,360NH	TK2042	ORDER BY DESCR
A1L609	108-0509-00		COIL,RF:FIXED,2.45UH	TK2042	ORDER BY DESCR
A1L610	108-0509-00		COIL,RF:FIXED,2.45UH	TK2042	ORDER BY DESCR
A1L619	108-0736-00		COIL,RF:FIXED,810NH	TK2042	ORDER BY DESCR
A1L628	108-0327-00		COIL,RF:FIXED,48NH	TK2042	ORDER BY DESCR
A1L633	108-0327-00		COIL,RF:FIXED,48NH	TK2042	ORDER BY DESCR
A1L644	114-0353-00		COIL,RF:VARIABLE,0.6-1.0UH	80009	114-0353-00
A1L733	108-1251-00		COIL,RF:FXD,2.7UH,10%	54583	SPT 0406-2R7K-6
A1L738	108-0317-00		COIL,RF:FIXED,15 UH	32159	71501M+10PERCENT
A1L740	108-0317-00		COIL,RF:FIXED,15 UH	32159	71501M+10PERCENT
A1L743	108-1251-00		COIL,RF:FXD,2.7UH,10%	54583	SPT 0406-2R7K-6
A1L938	108-1251-00		COIL,RF:FXD,2.7UH,10%	54583	SPT 0406-2R7K-6
A1L973	108-1251-00		COIL,RF:FXD,2.7UH,10%	54583	SPT 0406-2R7K-6
A1LR101	108-0325-00		COIL,RF:FIXED,490NH	TK2042	ORDER BY DESCR
A1LR107	108-0325-00		COIL,RF:FIXED,490NH	TK2042	ORDER BY DESCR
A1LR180	108-0602-00		COIL,RF:FIXED,45NH	TK2042	ORDER BY DESCR
A1LR201	108-0325-00		COIL,RF:FIXED,490NH	TK2042	ORDER BY DESCR
A1LR218	108-0330-00		COIL,RF:FIXED,395NH	TK2042	ORDER BY DESCR
A1LR219	108-0330-00		COIL,RF:FIXED,395NH	TK2042	ORDER BY DESCR
A1LR280	108-0602-00		COIL,RF:FIXED,45NH	TK2042	ORDER BY DESCR
A1Q130	151-0622-00		TRANSISTOR:PMP,SI,TO-92	04713	SP58956(MPSM51A)
A1Q131	151-0622-00		TRANSISTOR:PMP,SI,TO-92	04713	SP58956(MPSM51A)
A1Q154	151-0188-00		TRANSISTOR:PMP,SI,TO-92	80009	151-0188-00
A1Q155	151-0188-00		TRANSISTOR:PMP,SI,TO-92	80009	151-0188-00
A1Q190	151-0190-00		TRANSISTOR:PNP,SI,TO-92	80009	151-0190-00
A1Q460	151-0198-01		TRANSISTOR:PNP,SI,TO-92 PLSTC	80009	151-0198-01
A1Q550	151-0190-00		(QUANTITY OF 2,LOCATIONS A & B) TRANSISTOR:PNP,SI,TO-92	80009	151-0190-00

2455A Replaceable Electrical Parts
2445A/2455A Service

Component No.	Tektronix Part No.	Serial/Assembly No. Effective Dscont	Name & Description	Mfr. Code	Mfr. Part No.
A1Q600	151-0190-00		TRANSISTOR:NPN,SI,TO-92	80009	151-0190-00
A1Q623	151-0190-00		TRANSISTOR:NPN,SI,TO-92	80009	151-0190-00
A1Q624	151-1025-00		TRANSISTOR:FET,N-CHAN,SI,TO-92	04713	SPF3036
A1Q645	151-0188-00		TRANSISTOR:PMP,SI,TO-92	80009	151-0188-00
A1Q700	151-0190-00		TRANSISTOR:NPN,SI,TO-92	80009	151-0190-00
A1Q709	151-0736-01		TRANSISTOR:NPN,SI,TO-92	80009	151-0736-01
A1Q710	151-0736-01		TRANSISTOR:NPN,SI,TO-92	80009	151-0736-01
A1Q741	151-0188-00		TRANSISTOR:PMP,SI,TO-92	80009	151-0188-00
A1R100	315-0474-00		RES,FXD,FILM:470K OHM,5%,0.25M	19701	5043CX470K0J92U
A1R101	315-0272-00		RES,FXD,FILM:2.7K OHM,5%,0.25M	57668	NTR25J-E02K7
A1R102	315-0272-00		RES,FXD,FILM:2.7K OHM,5%,0.25M	57668	NTR25J-E02K7
A1R112	313-1101-00		RES,FXD,FILM:100 OHM,5%,0.2M	57668	TR20JE100E
A1R114	321-0130-03		RES,FXD,FILM:221 OHM,0.25%,0.125M,TC=T2 MI	91637	MFF18160221R0C
A1R115	321-0146-00		RES,FXD,FILM:324 OHM,1%,0.125M,TC=TO	07716	CEA0324R0F
A1R117	321-0320-00		RES,FXD,FILM:21.0K OHM,1%,0.125M,TC=TO	19701	5033ED21K00F
A1R118	321-0212-00		RES,FXD,FILM:1.58K OHM,1%,0.125M,TC=70	19701	5033ED1K58F
A1R121	315-0121-00		RES,FXD,FILM:120 OHM,5%,0.25M	19701	5043CX120R0J
A1R123	315-0622-00		RES,FXD,FILM:6.2K OHM,5%,0.25M	19701	5043CX6K200J
A1R125	301-0361-00		RES,FXD,FILM:360 OHM,5%,0.5M	19701	5053CX360R0J
A1R129	315-0101-00		RES,FXD,FILM:100 OHM,5%,0.25M	57668	NTR25J-E 100E
A1R130	315-0561-00		RES,FXD,FILM:560 OHM,5%,0.25M	19701	5043CX560R0J
A1R131	315-0561-00		RES,FXD,FILM:560 OHM,5%,0.25M	19701	5043CX560R0J
A1R133	315-0122-00		RES,FXD,FILM:1.2K OHM,5%,0.25M	57668	NTR25J-E01K2
A1R135	315-0102-00		RES,FXD,FILM:1K OHM,5%,0.25M	57668	NTR25JE01K0
A1R136	315-0622-00		RES,FXD,FILM:6.2K OHM,5%,0.25M	19701	5043CX6K200J
A1R140	315-0471-00		RES,FXD,FILM:470 OHM,5%,0.25M	57668	NTR25J-E470E
A1R141	315-0471-00		RES,FXD,FILM:470 OHM,5%,0.25M	57668	NTR25J-E470E
A1R142	315-0391-00		RES,FXD,FILM:390 OHM,5%,0.25M	57668	NTR25J-E390E
A1R143	315-0391-00		RES,FXD,FILM:390 OHM,5%,0.25M	57668	NTR25J-E390E
A1R144	307-0108-00		RES,FXD,CMPSN:6.8 OHM,5%,0.25M	01121	CB68G5
A1R149	315-0103-00		RES,FXD,FILM:10K OHM,5%,0.25M	19701	5043CX10K00J
A1R152	315-0562-00		RES,FXD,FILM:5.6K OHM,5%,0.25M	57668	NTR25J-E05K6
A1R153	315-0752-00		RES,FXD,FILM:7.5K OHM,5%,0.25M	57668	NTR25J-E07K5
A1R154	321-0210-00		RES,FXD,FILM:1.50K OHM,1%,0.125M,TC=TO	19701	5033ED1K50F
A1R155	321-0206-00		RES,FXD,FILM:1.37K OHM,1%,0.125M,TC=TO	07716	CEAD13700F
A1R156	321-0255-00		RES,FXD,FILM:4.42K OHM,1%,0.125M,TC=TO	19701	5033ED4K420F
A1R159	321-0242-00		RES,FXD,FILM:3.24K OHM,1%,0.125M,TC=TO	19701	5043ED3K240F
A1R161	321-0293-00		RES,FXD,FILM:11.0K OHM,1%,0.125M,TC=TO	07716	CEA011001F
A1R162	321-0293-00		RES,FXD,FILM:11.0K OHM,1%,0.125M,TC=TO	07716	CEA011001F
A1R163	321-0242-00		RES,FXD,FILM:3.24K OHM,1%,0.125M,TC=TO	19701	5043ED3K240F
A1R165	315-0822-00		RES,FXD,FILM:8.2K OHM,5%,0.25M	19701	5043CX8K200J
A1R180	322-3242-00		RES,FXD,FILM:3.24K OHM,1%,0.2M,TC=TO	57668	CR820 FXE 3K24
A1R181	322-3289-00		RES,FXD,FILM:10K OHM,1%,0.2M,TC=TO	57668	CR820 FXE 10K0
A1R182	322-3242-00		RES,FXD,FILM:3.24K OHM,1%,0.2M,TC=TO	57668	CR820 FXE 3K24
A1R183	322-3289-00		RES,FXD,FILM:10K OHM,1%,0.2M,TC=TO	57668	CR820 FXE 10K0
A1R190	315-0103-00		RES,FXD,FILM:10K OHM,5%,0.25M	19701	5043CX10K00J
A1R191	315-0103-00		RES,FXD,FILM:10K OHM,5%,0.25M	19701	5043CX10K00J
A1R192	315-0103-00		RES,FXD,FILM:10K OHM,5%,0.25M	19701	5043CX10K00J
A1R193	315-0102-00		RES,FXD,FILM:1K OHM,5%,0.25M	57668	NTR25JE01K0
A1R194	315-0103-00		RES,FXD,FILM:10K OHM,5%,0.25M	19701	5043CX10K00J
A1R195	315-0301-00		RES,FXD,FILM:300 OHM,5%,0.25M	57668	NTR25J-E300E
A1R196	315-0752-00		RES,FXD,FILM:7.5K OHM,5%,0.25M	57668	NTR25J-E07K5
A1R197	315-0562-00		RES,FXD,FILM:5.6K OHM,5%,0.25M	57668	NTR25J-E05K6
A1R198	321-1700-04		RES,FXD,FILM:10.44K OHM,0.1%,0.125M,TC=T2	19701	5033RC10K440B
A1R199	321-1700-04		RES,FXD,FILM:10.44K OHM,0.1%,0.125M,TC=T2	19701	5033RC10K440B
A1R200	315-0474-00		RES,FXD,FILM:470K OHM,5%,0.25M	19701	5043CX470K0J92U
A1R201	315-0272-00		RES,FXD,FILM:2.7K OHM,5%,0.25M	57668	NTR25J-E02K7
A1R202	315-0272-00		RES,FXD,FILM:2.7K OHM,5%,0.25M	57668	NTR25J-E02K7
A1R216	315-0121-00		RES,FXD,FILM:120 OHM,5%,0.25M	19701	5043CX120R0J

2455A Replaceable Electrical Parts
2445A/2455A Service

Component No.	Tektronix Part No.	Serial/Assembly No. Effective Dscont	Name & Description	Mfr. Code	Mfr. Part No.
A1R217	321-0320-00		RES,FXD,FILM:21.0K OHM,1%,0.125M,TC=TO	19701	5033ED21K00F
A1R218	321-0212-00		RES,FXD,FILM:1.58K OHM,1%,0.125M,TC=70	19701	5033ED1K58F
A1R225	301-0361-00		RES,FXD,FILM:360 OHM,5%,0.5M	19701	5053CX360R0J
A1R230	315-0222-00		RES,FXD,FILM:2.2K OHM,5%,0.25M	57668	NTR25J-ED2K2
A1R231	315-0222-00		RES,FXD,FILM:2.2K OHM,5%,0.25M	57668	NTR25J-ED2K2
A1R232	315-0222-00		RES,FXD,FILM:2.2K OHM,5%,0.25M	57668	NTR25J-ED2K2
A1R301	315-0240-00		RES,FXD,FILM:24 OHM,5%,0.25M	57668	NTR25J-E24E0
A1R302	315-0240-00		RES,FXD,FILM:24 OHM,5%,0.25M	57668	NTR25J-E24E0
A1R303	315-0101-00		RES,FXD,FILM:100 OHM,5%,0.25M	57668	NTR25J-E 100E
A1R304	315-0101-00		RES,FXD,FILM:100 OHM,5%,0.25M	57668	NTR25J-E 100E
A1R311	315-0101-00		RES,FXD,FILM:100 OHM,5%,0.25M	57668	NTR25J-E 100E
A1R312	315-0101-00		RES,FXD,FILM:100 OHM,5%,0.25M	57668	NTR25J-E 100E
A1R329	315-0101-00		RES,FXD,FILM:100 OHM,5%,0.25M	57668	NTR25J-E 100E
A1R332	315-0101-00		RES,FXD,FILM:100 OHM,5%,0.25M	57668	NTR25J-E 100E
A1R353	321-0239-00		RES,FXD,FILM:3.01K OHM,1%,0.125M,TC=TO	19701	5043ED3K010F
A1R361	321-0265-00		RES,FXD,FILM:5.62K OHM,1%,0.125M,TC=TO	19701	5043ED5K620F
A1R401	321-0202-00		RES,FXD,FILM:1.24K OHM,1%,0.125M,TC=TO	24546	NA5501241F
A1R402	315-0750-00		RES,FXD,FILM:75 OHM,5%,0.25M	57668	NTR25J-E75E0
A1R403	311-0607-00		RES,VAR,NONMM:TRMR,10K OHM,0.5M	73138	82-25-2
A1R404	313-1200-00		RES,FXD,FILM:20 OHM,5%,0.2M	57668	TR20JE20E
A1R405	313-1200-00		RES,FXD,FILM:20 OHM,5%,0.2M	57668	TR20JE20E
A1R410	311-0634-00		RES,VAR,NONMM:TRMR,500 OHM,0.5M	32997	3329H-L58-501
A1R412	315-0750-00		RES,FXD,FILM:75 OHM,5%,0.25M	57668	NTR25J-E75E0
A1R416	315-0102-00		RES,FXD,FILM:1K OHM,5%,0.25M	57668	NTR25JED1K0
A1R417	311-2234-00		RES,VAR,NONMM:TRMR,5K OHM,20%,0.5M	TK1450	GFD6UT 5K
A1R430	315-0750-00		RES,FXD,FILM:75 OHM,5%,0.25M	57668	NTR25J-E75E0
A1R450	321-0310-00		RES,FXD,FILM:16.5K OHM,1%,0.125M,TC=TO	19701	5033ED16K50F
A1R451	321-0275-00		RES,FXD,FILM:7.15K OHM,1%,0.125M,TC=TO	07716	CEA071500F
A1R452	321-0310-00		RES,FXD,FILM:16.5K OHM,1%,0.125M,TC=TO	19701	5033ED16K50F
A1R453	321-0275-00		RES,FXD,FILM:7.15K OHM,1%,0.125M,TC=TO	07716	CEA071500F
A1R454	321-0310-00		RES,FXD,FILM:16.5K OHM,1%,0.125M,TC=TO	19701	5033ED16K50F
A1R455	321-0310-00		RES,FXD,FILM:16.5K OHM,1%,0.125M,TC=TO	19701	5033ED16K50F
A1R456	321-0333-00		RES,FXD,FILM:28.7K OHM,1%,0.125M,TC=TO	19701	5043ED28K70F
A1R457	321-0275-00		RES,FXD,FILM:7.15K OHM,1%,0.125M,TC=TO	07716	CEA071500F
A1R458	321-0085-00		RES,FXD,FILM:75 OHM,1%,0.125M,TC=TO	57668	CR814FXE 75 OHM
A1R459	321-0085-00		RES,FXD,FILM:75 OHM,1%,0.125M,TC=TO	57668	CR814FXE 75 OHM
A1R460	321-0062-00		RES,FXD,FILM:43.2 OHM,0.5%,0.125M,TC=TO	57668	CR814 FXE 43.2
A1R461	321-0139-00		RES,FXD,FILM:274 OHM,1%,0.125M,TC=TO	07716	CEA0274R0F
A1R462	321-0201-00		RES,FXD,FILM:1.21K OHM,1%,0.125M,TC=TO	19701	5043ED1K210F
A1R463	321-0193-00		RES,FXD,FILM:1K OHM,1%,0.125M,TC=TO	19701	5033ED1K00F
A1R464	321-0063-00		RES,FXD,FILM:44.2 OHM,0.5%,0.125M,TC=TO	91637	CMF55116G44R20F
A1R465	321-0193-00		RES,FXD,FILM:1K OHM,1%,0.125M,TC=TO	19701	5033ED1K00F
A1R468	321-0287-00		RES,FXD,FILM:9.53K OHM,1%,0.125M,TC=TO	19701	5033ED9K530F
A1R469	315-0200-00		RES,FXD,FILM:20 OHM,5%,0.25M	19701	5043CX20R00J
A1R470	315-0223-00		RES,FXD,FILM:22K OHM,5%,0.25M	19701	5043CX22K00J92U
A1R471	315-0223-00		RES,FXD,FILM:22K OHM,5%,0.25M	19701	5043CX22K00J92U
A1R473	315-0471-00		RES,FXD,FILM:470 OHM,5%,0.25M	57668	NTR25J-E470E
A1R476	315-0750-00		RES,FXD,FILM:75 OHM,5%,0.25M	57668	NTR25J-E75E0
A1R477	315-0472-00		RES,FXD,FILM:4.7K OHM,5%,0.25M	57668	NTR25J-E04K7
A1R478	321-0193-03		RES,FXD,FILM:1K OHM,0.25%,0.125M,TC=T2	07716	CEAC10000C
A1R479	315-0102-00		RES,FXD,FILM:1K OHM,5%,0.25M	57668	NTR25JED1K0
A1R480	321-0375-00		RES,FXD,FILM:78.7K OHM,1%,0.125M,TC=TO	07716	CEA078701F
A1R481	321-0347-00		RES,FXD,FILM:40.2K OHM,1%,0.125M,TC=TO	91637	CMF55116G40201F
A1R482	315-0471-00		RES,FXD,FILM:470 OHM,5%,0.25M	57668	NTR25J-E470E
A1R483	321-0347-00		RES,FXD,FILM:40.2K OHM,1%,0.125M,TC=TO	91637	CMF55116G40201F
A1R484	315-0202-00		RES,FXD,FILM:2K OHM,5%,0.25M	57668	NTR25J-E 2K
A1R485	315-0202-00		RES,FXD,FILM:2K OHM,5%,0.25M	57668	NTR25J-E 2K
A1R486	321-0347-00		RES,FXD,FILM:40.2K OHM,1%,0.125M,TC=TO	91637	CMF55116G40201F

2455A Replaceable Electrical Parts
2445A/2455A Service

Component No.	Tektronix Part No.	Serial/Assembly No. Effective Decont	Name & Description	Mfr. Code	Mfr. Part No.
A1R487	321-0130-03		RES, FXD, FILM: 221 OHM, 0.25%, 0.125M, TC=T2 MI	91637	MFF18160221R0C
A1R488	321-1216-03		RES, FXD, FILM: 1.76K OHM, 0.25%, 0.125M, TC=T2	24546	NC55C1761C
A1R489	321-1216-03		RES, FXD, FILM: 1.76K OHM, 0.25%, 0.125M, TC=T2	24546	NC55C1761C
A1R490	321-0375-00		RES, FXD, FILM: 78.7K OHM, 1%, 0.125M, TC=T0	07716	CEA078701F
A1R491	315-0102-00		RES, FXD, FILM: 1K OHM, 5%, 0.25M	57668	NTR25JE01K0
A1R492	321-0193-03		RES, FXD, FILM: 1K OHM, 0.25%, 0.125M, TC=T2	07716	CEAC10000C
A1R493	315-0472-00		RES, FXD, FILM: 4.7K OHM, 5%, 0.25M	57668	NTR25J-ED4K7
A1R494	315-0201-00		RES, FXD, FILM: 200 OHM, 5%, 0.25M	57668	NTR25J-E200E
A1R495	315-0750-00		RES, FXD, FILM: 75 OHM, 5%, 0.25M	57668	NTR25J-E75E0
A1R496	315-0113-00		RES, FXD, FILM: 11K OHM, 5%, 0.25M	19701	5043CX11K00J
A1R497	315-0821-00		RES, FXD, FILM: 820 OHM, 5%, 0.25M	19701	5043CX820R0J
A1R498	315-0821-00		RES, FXD, FILM: 820 OHM, 5%, 0.25M	19701	5043CX820R0J
A1R500	315-0331-00		RES, FXD, FILM: 330 OHM, 5%, 0.25M	57668	NTR25J-E330E
A1R501	315-0101-00		RES, FXD, FILM: 100 OHM, 5%, 0.25M	57668	NTR25J-E 100E
A1R502	315-0622-00		RES, FXD, FILM: 6.2K OHM, 5%, 0.25M	19701	5043CX6K200J
A1R503	315-0103-00		RES, FXD, FILM: 10K OHM, 5%, 0.25M	19701	5043CX10K00J
A1R504	315-0103-00		RES, FXD, FILM: 10K OHM, 5%, 0.25M	19701	5043CX10K00J
A1R511	321-0320-00		RES, FXD, FILM: 21.0K OHM, 1%, 0.125M, TC=T0	19701	5033E021K00F
A1R512	321-0293-00		RES, FXD, FILM: 11.0K OHM, 1%, 0.125M, TC=T0	07716	CEA011001F
A1R513	315-0470-00		RES, FXD, FILM: 47 OHM, 5%, 0.25M	57668	NTR25J-E47E0
A1R518	315-0680-00		RES, FXD, FILM: 68 OHM, 5%, 0.25M	57668	NTR25J-E68E0
A1R519	315-0621-00		RES, FXD, FILM: 620 OHM, 5%, 0.25M	57668	NTR25J-E620E
A1R520	315-0393-00		RES, FXD, FILM: 39K OHM, 5%, 0.25M	57668	NTR25J-E39K0
A1R521	315-0750-00		RES, FXD, FILM: 75 OHM, 5%, 0.25M	57668	NTR25J-E75E0
A1R527	315-0750-00		RES, FXD, FILM: 75 OHM, 5%, 0.25M	57668	NTR25J-E75E0
A1R529	315-0561-00		RES, FXD, FILM: 560 OHM, 5%, 0.25M	19701	5043CX560R0J
A1R537	315-0101-00		RES, FXD, FILM: 100 OHM, 5%, 0.25M	57668	NTR25J-E 100E
A1R538	315-0621-00		RES, FXD, FILM: 620 OHM, 5%, 0.25M	57668	NTR25J-E620E
A1R542	315-0680-00		RES, FXD, FILM: 68 OHM, 5%, 0.25M	57668	NTR25J-E68E0
A1R543	315-0621-00		RES, FXD, FILM: 620 OHM, 5%, 0.25M	57668	NTR25J-E620E
A1R544	315-0393-00		RES, FXD, FILM: 39K OHM, 5%, 0.25M	57668	NTR25J-E39K0
A1R545	315-0750-00		RES, FXD, FILM: 75 OHM, 5%, 0.25M	57668	NTR25J-E75E0
A1R550	315-0471-00		RES, FXD, FILM: 470 OHM, 5%, 0.25M	57668	NTR25J-E470E
A1R551	321-1682-07		RES, FXD, FILM: 5.7K OHM, 0.1%, 0.125M, TC=T9	19701	5033RESK701B
A1R552	321-0641-07		RES, FXD, FILM: 1.8K OHM, 0.190, 0.125M, TC=T9	07716	CEAE 180008
A1R553	315-0152-00		RES, FXD, FILM: 1.5K OHM, 5%, 0.25M	57668	NTR25J-ED1K5
A1R554	315-0162-00		RES, FXD, FILM: 1.6K OHM, 5%, 0.25M	19701	5043CX1K600J
A1R555	321-0294-00		RES, FXD, FILM: 11.3K OHM, 1%, 0.125M, TC=T0	19701	5043E011K30F
A1R556	321-0282-00		RES, FXD, FILM: 8.45K OHM, 1%, 0.125M, TC=T0	07716	CFAD084500F
A1R557	321-0808-07		RES, FXD, FILM: 300 OHM, 0.1%, 0.125M, TC=T9	24546	NE55E30008
A1R558	321-0657-07		RES, FXD, FILM: 60 OHM, 0.1%, 0.125M, TC=T9	57668	R8148ZE 60E
A1R560	315-0621-00		RES, FXD, FILM: 620 OHM, 5%, 0.25M	57668	NTR25J-E620E
A1R600	315-0270-00		RES, FXD, FILM: 27 OHM, 5%, 0.25M	19701	5043CX27R00J
A1R601	313-1750-00		RES, FXD, FILM: 75 OHM, 5%, 0.2M	57668	TR20JE 75E
A1R602	315-0470-00		RES, FXD, FILM: 47 OHM, 5%, 0.25M	57668	NTR25J-E47E0
A1R605	311-2227-00		RES, VAR, NONMM: TRMR, 100 OHM, 20%, 0.5M LINEAR	TK1450	GF06UT 100
A1R606	315-0100-00		RES, FXD, FILM: 10 OHM, 5%, 0.25M	19701	5043CX10RR00J
A1R607	315-0100-00		RES, FXD, FILM: 10 OHM, 5%, 0.25M	19701	5043CX10RR00J
A1R610	307-0106-00		RES, FXD, CMPSM: 4.7 OHM, 5%, 0.25M	01121	CB 47G5
A1R614	315-0103-00		RES, FXD, FILM: 10K OHM, 5%, 0.25M	19701	5043CX10K00J
A1R615	315-0103-00		RES, FXD, FILM: 10K OHM, 5%, 0.25M	19701	5043CX10K00J
A1R617	315-0102-00		RES, FXD, FILM: 1K OHM, 5%, 0.25M	57668	NTR25JE01K0
A1R618	311-2234-00		RES, VAR, NONMM: TRMR, 5K OHM, 20%, 0.5M	TK1450	GF06UT 5K
A1R619	315-0510-00		RES, FXD, FILM: 51 OHM, 5%, 0.25M	19701	5043CX51R00J
A1R620	315-0472-00		RES, FXD, FILM: 4.7K OHM, 5%, 0.25M	57668	NTR25J-ED4K7
A1R622	321-0226-00		RES, FXD, FILM: 2.21K OHM, 1%, 0.125M, TC=T0	01121	RNK2211F
A1R623	315-0101-00		RES, FXD, FILM: 100 OHM, 5%, 0.25M	57668	NTR25J-E 100E
A1R624	315-0100-00		RES, FXD, FILM: 10 OHM, 5%, 0.25M	19701	5043CX10RR00J
A1R637	322-3222-00		RES, FXD, FILM: 2K OHM, 1%, 0.2M, TC=T0	57668	CR820 FXE 2K00

2455A Replaceable Electrical Parts
2445A/2455A Service

Component No.	Tektronix Part No.	Serial/Assembly No. Effective Decont	Name & Description	Mfr. Code	Mfr. Part No.
A1R638	311-2234-00		RES,VAR,NONHM:TRMR,5K OHM,20%,0.5M	TK1450	GFD6UT 5K
A1R639	311-2230-III		RES,VAR,NONHM:TRMR,500 OHM,20%,0.5M LINEAR	TK1450	GFD6UT 500
A1R642	315-0432-00		RES,FXD,FILM:4.3K OHM,5%,0.25M	57668	NTR25J-ED4K3
A1R643	315-0750-00		RES,FXD,FILM:75 OHM,5%,0.25M	57668	NTR25J-E75ED
A1R644	315-0472-00		RES,FXD,FILM:4.7K OHM,5%,0.25M	57668	NTR25J-ED4K7
A1R645	321-0625-00		RES,FXD,FILM:5.88K OHM,1%,0.125M,TC=TO	91637	WFF1816658800F
A1R646	321-0252-00		RES,FXD,FILM:4.12K OHM,1%,0.125M,TC=TO	07716	CEAD41200F
A1R650	315-0203-00		RES,FXD,FILM:20K OHM,5%,0.25M	57668	NTR25J-E 20K
A1R651	315-0911-00		RES,FXD,FILM:910 OHM,5%,0.25M	57668	NTR25J-E910E
A1R652	315-0274-00		RES,FXD,FILM:270K OHM,5%,0.25M	57668	NTR25J-E270K
A1R653	315-0102-00		RES,FXD,FILM:1K OHM,5%,0.25M	57668	NTR25JED1K0
A1R655	315-0102-00		RES,FXD,FILM:1K OHM,5%,0.25M	57668	NTR25JED1K0
A1R659	321-0147-00		RES,FXD,FILM:332 OHM,1%,0.125M,TC=TO	07716	CEAD332R0F
A1R669	321-0995-00		RES,FXD,FILM:549K OHM,1%,0.125M,TC=TO	24546	N05505493F
A1R670	315-0102-00		RES,FXD,FILM:1K OHM,5%,0.25M	57668	NTR25JED1K0
A1R671	315-0103-00		RES,FXD,FILM:10K OHM,5%,0.25M	19701	5043CX10K00J
A1R678	315-0102-00		RES,FXD,FILM:1K OHM,5%,0.25M	57668	NTR25JED1K0
A1R700	315-0221-00		RES,FXD,FILM:220 OHM,5%,0.25M	57668	NTR25J-E220E
A1R701	321-0223-00		RES,FXD,FILM:2.05K OHM,1%,0.125M,TC=TO	80009	321-0223-00
A1R702	321-0252-00		RES,FXD,FILM:4.12K OHM,1%,0.125M,TC=TO	07716	CEAD41200F
A1R707	315-0122-00		RES,FXD,FILM:1.2K OHM,5%,0.25M	57668	NTR25J-ED1K2
A1R708	315-0242-00		RES,FXD,FILM:2.4K OHM,5%,0.25M	57668	NTR25J-ED2K4
A1R709	315-0472-00		RES,FXD,FILM:4.7K OHM,5%,0.25M	57668	NTR25J-ED4K7
A1R710	315-0396-00		RES,FXD,FILM:39M OHM,5%,0.25M	01121	CB3965
A1R713	315-0822-00		RES,FXD,FILM:8.2K OHM,5%,0.25M	19701	5043CX8K200J
A1R723	321-0245-00		RES,FXD,FILM:3.48K OHM,1%,0.125M,TC=TO	19701	5033ED3K48F
A1R724	321-0680-00		RES,FXD,FILM:35.3K OHM,0.5%,0.125M,TC=T2	19701	5033RC35K300
A1R731	315-0153-00		RES,FXD,FILM:15K OHM,5%,0.25M	19701	5043CX15K00J
A1R732	315-0682-00		RES,FXD,FILM:6.8K OHM,5%,0.25M	57668	NTR25J-ED6K8
A1R733	315-0182-00		RES,FXD,FILM:1.8K OHM,5%,0.25M	57668	NTR25J-E1K8
A1R734	315-0221-00		RES,FXD,FILM:220 OHM,5%,0.25M	57668	NTR25J-E220E
A1R735	315-0273-00		RES,FXD,FILM:27K OHM,5%,0.25M	57668	NTR25J-E27K0
A1R736	321-0217-00		RES,FXD,FILM:1.78K OHM,1%,0.125M,TC=TO	19701	5043D1K780F
A1R737	321-0263-00		RES,FXD,FILM:5.36K OHM,1%,0.125M,TC=TO	07716	CEAD53600F
A1R738	321-0273-00		RES,FXD,FILM:6.81K OHM,1%,0.125M,TC=TO	07716	CEAD68100F
A1R741	315-0272-00		RES,FXD,FILM:2.7K OHM,5%,0.25M	57668	NTR25J-ED2K7
A1R742	315-0151-00		RES,FXD,FILM:150 OHM,5%,0.25M	57668	NTR25J-E150E
A1R743	315-0102-00		RES,FXD,FILM:1K OHM,5%,0.25M	57668	NTR25JED1K0
A1R744	315-0750-00		RES,FXD,FILM:75 OHM,5%,0.25M	57668	NTR25J-E75ED
A1R745	315-0242-00		RES,FXD,FILM:2.4K OHM,5%,0.25M	57668	NTR25J-ED2K4
A1R746	301-0470-00		RES,FXD,FILM:47 OHM,5%,0.5M	19701	5053CX47R00J
A1R750	315-0271-00		RES,FXD,FILM:270 OHM,5%,0.25M	57668	NTR25J-E270E
A1R751	315-0622-00		RES,FXD,FILM:6.2K OHM,5%,0.25M	19701	5043CX6K200J
A1R752	321-0269-00		RES,FXD,FILM:6.19K OHM,1%,0.125M,TC=TO	07716	CEAD61900F
A1R753	321-0265-00		RES,FXD,FILM:5.62K OHM,1%,0.125M,TC=TO	19701	5043ED5K620F
A1R754	315-0104-00		RES,FXD,FILM:100K OHM,5%,0.25M	57668	NTR25J-E100K
A1R800	321-0147-00		RES,FXD,FILM:332 OHM,1%,0.125M,TC=TO	07716	CEAD332R0F
A1R801	311-2230-00		RES,VAR,NONHM:TRMR,500 OHM,20%,0.50 LINEAR	TK1450	GFD6UT 500
A1R802	313-1222-00		RES,FXD,FILM:2.2K OHM,5%,0.2M	57668	TR20JE 02K2
A1R803	313-1821-00		RES,FXD,FILM:820 OHM,5%,0.2M	57668	TR20JE 820E
A1R804	315-0151-00		RES,FXD,FILM:150 OHM,5%,0.25M	57668	NTR25J-E150E
A1R805	311-1242-00		RES,VAR,NONHM:TRMR,200K OHM,0.5M	32997	3386X-T07-204
A1R806	315-0204-00		RES,FXD,FILM:200K OHM,5%,0.25M	19701	5043CX200K0J
A1R809	315-0151-00		RES,FXD,FILM:150 OHM,5%,0.25M	57668	NTR25J-E150E
A1R811	301-0331-00		RES,FXD,FILM:330 OHM,5%,0.5M	19701	5053CX330R0J
A1R817	315-0221-00		RES,FXD,FILM:220 OHM,5%,0.25M	57668	NTR25J-E220E
A1R820	321-0337-00		RES,FXD,FILM:31.6K OHM,1%,0.125M,TC=TO	07716	CEAD31601F
A1R821	321-0330-00		RES,FXD,FILM:26.7K OHM,1%,0.125M,TC=TO	07716	CEAD26701F
A1R822	315-0271-00		RES,FXD,FILM:270 OHM,5%,0.25M	57668	NTR25J-E270E

2455A Replaceable Electrical Parts
2445A/2455A Service

Component No.	Tektronix Part No.	Serial/Assembly No. Effective Dscont	Name & Description	Mfr. Code	Mfr. Part No.
A1R823	321-0193-00		RES,FXD,FILM:1K OHM,1%,0.125M,TC=TO	19701	5033ED1K00F
A1R849	315-0333-00		RES,FXD,FILM:33K OHM,5%,0.25M	57668	NTR25J-E33K0
A1R850	311-2234-00		RES,VAR,NONMM:TRMR,5K OHM,20%,0.5M	TK1450	GF06UT 5K
A1R852	315-0240-00		RES,FXD,FILM:24 OHM,5%,0.25M	57668	NTR25J-E24E0
A1R853	315-0240-00		RES,FXD,FILM:24 OHM,5%,0.25M	57668	NTR25J-E24E0
A1R855	315-0103-00		RES,FXD,FILM:10K OHM,5%,0.25M	19701	5043CX10K00J
A1R856	321-0210-00		RES,FXD,FILM:1.50K OHM,1%,0.125M,TC=TO	19701	5033E01K50F
A1R858	321-0239-00		RES,FXD,FILM:3.01K OHM,1%,0.125M,TC=TO	19701	5043E03K010F
A1R860	311-2234-00		RES,VAR,NONMM:TRMR,5K OHM,20%,0.5M	TK1450	GF06UT 5K
A1R901	315-0112-00		RES,FXD,FILM:1.1K OHM,5%,0.25M	19701	5043CX1K100J
A1R903	315-0472-00		RES,FXD,FILM:4.7K OHM,5%,0.25M	57668	NTR25J-E04K7
A1R904	315-0124-00		RES,FXD,FILM:120K OHM,5%,0.25M	19701	5043CX120K0J
A1R907	315-0471-00		RES,FXD,FILM:470 OHM,5%,0.25M	57668	NTR25J-E470E
A1R910	315-0396-00		RES,FXD,FILM:39M OHM,5%,0.25M	01121	CB3965
A1R912	315-0822-00		RES,FXD,FILM:8.2K OHM,5%,0.25M	19701	5043CX8K200J
A1R924	321-0325-00		RES,FXD,FILM:23.7K OHM,1%,0.125M,TC=TO	07716	CEA023701F
A1R936	321-0225-00		RES,FXD,FILM:2.15K OHM,1%,0.125M,TC=TO	19701	5033E02K15F
A1R937	321-0268-00		RES,FXD,FILM:6.04K OHM,1%,0.125M,TC=TO	19701	5043E06K040F
A1R939	315-0332-00		RES,FXD,FILM:3.3K OHM,5%,0.25M	57668	NTR25J-E03K3
A1R940	315-0101-00		RES,FXD,FILM:100 OHM,5%,0.25M	57668	NTR25J-E 100E
A1R941	315-0561-00		RES,FXD,FILM:560 OHM,5%,0.25M	19701	5043CX560R0J
A1R942	321-0256-00		RES,FXD,FILM:4.53K OHM,1%,0.125M,TC=T9	19701	5033E04K530F
A1R943	315-0121-00		RES,FXD,FILM:120 OHM,5%,0.25M	19701	5043CX120R0J
A1R944	317-0302-00		RES,FXD,CMPSN:3K OHM,5%,0.125M	01121	B83025
A1R945	315-0621-00		RES,FXD,FILM:620 OHM,5%,0.25M	57668	NTR25J-E620E
A1R947	321-0117-00		RES,FXD,FILM:162 OHM,1%,0.125M,TC=TO	07716	CEA0162R0F
A1R950	301-0470-00		RES,FXD,FILM:47 OHM,5%,0.5M	19701	5053CX47R00J
A1R951	308-0555-00		RES,FXD,MM:5 OHM,5%,3M	00213	1200S-5.0-5
A1R952	315-0750-00		RES,FXD,FILM:75 OHM,5%,0.25M	57668	NTR25J-E75E0
A1R956	315-0302-00		RES,FXD,FILM:3K OHM,5%,0.25M	57668	NTR25J-E03K0
A1R957	321-0291-00		RES,FXD,FILM:10.5K OHM,1%,0.125M,TC=TO	80009	321-0291-00
A1R972	315-0510-00		RES,FXD,FILM:51 OHM,5%,0.25M	19701	5043CX51R00J
A1R973	315-0513-00		RES,FXD,FILM:51K OHM,5%,0.25M	57668	NTR25J-E51K0
A1R981	315-0101-00		RES,FXD,FILM:100 OHM,5%,0.25M	57668	NTR25J-E 100E
A1R982	321-0103-00		RES,FXD,FILM:115 OHM,1%,0.125M,TC=TO	01121	RNK1150F
A1R983	315-0101-00		RES,FXD,FILM:100 OHM,5%,0.25M	57668	NTR25J-E 100E
A1R984	315-0101-00		RES,FXD,FILM:100 OHM,5%,0.25M	57668	NTR25J-E 100E
A1R995	315-0512-00		RES,FXD,FILM:5.1K OHM,5%,0.25M	57668	NTR25J-E05K1
A1S615	260-1421-00		SWITCH,PUSH:1 BTN,2 POLE,INSTRUMENT ID	59821	ORDER BY DESC
A1U100	153-2235-01		MICROCKT,LINEAR:MTCHD PR,L NOISE VRT PREAMP (MATCHED WITH A1U200)	80009	153-2235-01
A1U110	156-1245-00		MICROCKT,LINEAR:7 XSTR,NPN,SI,HV/HIGH CUR	01295	ULN2003AN-P3
A1U120	156-1245-00		MICROCKT,LINEAR:7 XSTR,NPN,SI,HV/HIGH CUR	01295	ULN2003AN-P3
A1U130	156-1245-00		MICROCKT,LINEAR:7 XSTR,NPN,SI,HV/HIGH CUR	01295	ULN2003AN-P3
A1U140	156-0651-02		MICROCKT,DGTL:8-BIT PRL-OUT SER SHF RGTR	01295	SN74LS164NP3
A1U150	156-0651-02		MICROCKT,DGTL:8-BIT PRL-OUT SER SHF RGTR	01295	SN74LS164NP3
A1U160	156-1200-01		MICROCKT,LINEAR:OPERATIONAL AMPL,QUAD BIFET	80009	156-1200-01
A1U165	156-2854-00		MICROCKT,LINEAR:CMOS,OP AMPL QUAD	80009	156-2854-00
A1U170	156-0513-03		MICROCKT,LINEAR:CMOS,8 CHAN ANALOG MUX	04713	MC14051BCL
A1U180	156-1191-01		MICROCKT,LINEAR:DUAL BI-FET OP-AMP,8 DIP	80009	156-1191-01
A1U200	153-2235-01		MICROCKT,LINEAR:MTCHD PR,L NOISE VRT PREAMP (MATCHED WITH A1U100)	80009	153-2235-01
A1U300	155-0238-00		MICROCKT,LINEAR:TRIGGER PREAMP	80009	155-0238-00
A1U350	156-1191-01		MICROCKT,LINEAR:DUAL BI-FET OP-AMP,8 DIP	80009	156-1191-01
A1U400	155-0236-00		MICROCKT,LINEAR:VERTICAL CHANNEL SWITCH	80009	155-0236-00
A1U450	156-0158-07		MICROCKT,LINEAR:DUAL OPNL AMPL,SCREENEO	01295	MC1458JG4
A1U475	156-0048-00		MICROCKT,LINEAR:5 XSTR ARRAY	02735	CA3046
A1U485	156-0048-00		MICROCKT,LINEAR:5 XSTR ARRAY	02735	CA3046
A1U500	155-0239-02		MICROCKT,LINEAR:TRIGGER	80009	155-0239-02

2455A Replaceable Electrical Parts
2445A/2455A Service

Component No.	Tektronix Part No.	Serial/Assembly No. Effective Dscont	Name & Description	Mfr. Code	Mfr. Part No.
A1U550	156-0048-00		MICROCKT,LINEAR:5 XSTR ARRAY	02735	CA3046
A1U600	155-0237-01		MICROCKT,LINEAR:VERTICAL OUTPUT TESTED	80009	155-0237-01
A1U650	155-0244-01		MICROCKT,DGTL:SYSTEM LOGIC INTERFACE	31471	M 217
A1U700	155-0240-00		MICROCKT,LINEAR:SNEEP	80009	155-0240-00
A1U735	156-0048-00		MICROCKT,LINEAR:5 XSTR ARRAY	02735	CA3046
A1U800	155-0241-02		MICROCKT,DGTL:HORIZONTAL AMP SYS	80009	155-0241-02
A1U850	156-0515-02		MICROCKT,DGTL:TRIPLE 3-CHAN MUX,SEL	80009	156-0515-02
A1U860	156-0515-02		MICROCKT,DGTL:TRIPLE 3-CHAN MUX,SEL	80009	156-0515-02
A1U900	155-0240-00		MICROCKT,LINEAR:SNEEP	80009	155-0240-00
A1U910	156-1191-01		MICROCKT,LINEAR:OVAL BI-FET OP-AMP,8 DIP	80009	156-1191-01
A1U950	155-0242-01		MICROCKT,LINEAR:Z AXIS AUTOFOCUS	80009	155-0242-01
A1U975	156-0382-02		MICROCKT,DGTL:QUAD 2 INP NAND GATE BURN	18324	N74LS00NB
A1U980	156-1724-00		MICROCKT,DGTL:QUAD 2 INPUT OR GATE	04713	MC74F32ND
A1VR112	152-0166-00		SEMICONO OVC,OI:ZEN,SI,6.2V,5%,0.4M,00-7	04713	SZ11738RL
A1VR125	152-0166-00		SEMICONO OVC,OI:ZEN,SI,6.2V,5%,0.4M,00-7	04713	SZ11738RL
A1VR225	152-0166-00		SEMICONO OVC,OI:ZEN,SI,6.2V,5%,0.4M,00-7	04713	SZ11738RL
A1VR550	152-0195-00		SEMICONO OVC,OI:ZEN,SI,5.1V,5%,0.4M,00-7	04713	SZ11755RL
A1M101	131-0566-00		BUS,COND:DUMMY RES,0.094 00 X 0.225L	24546	OMA 07
A1M102	131-0566-00		BUS,COND:DUMMY RES,0.094 00 X 0.225L	24546	OMA 07
A1M103	131-0566-00		BUS,COND:DUMMY RES,0.094 00 X 0.225L	24546	OMA 07
A1M104	131-0566-00		BUS,COND:DUMMY RES,0.094 00 X 0.225L	24546	OMA 07
A1M105	131-0566-00		BUS,COND:DUMMY RES,0.094 00 X 0.225L	24546	OMA 07
A1M106	195-6500-02		LEAD,ELECTRICAL:22 AWG,1.75 L,9-N	TK1544	195-6500-02
A1M107	195-6500-02		LEAD,ELECTRICAL:22 AWG,1.75 L,9-N	TK1544	195-6500-02
A1M108	195-6500-02		LEAD,ELECTRICAL:22 AWG,1.75 L,9-N	TK1544	195-6500-02
A1M109	131-0566-00		BUS,COND:DUMMY RES,0.094 00 X 0.225L	24546	OMA 07
A1M120	131-0566-00		BUS,COND:DUMMY RES,0.094 00 X 0.225L	24546	OMA 07
A1M121	175-4594-01		CA ASSY,SP,ELEC:6,22 AWG,5.25 L	80009	175-4594-01
A1M122	175-4598-00		CA ASSY,SP,ELEC:8,26 AWG,7.0 L,RIBBON	80009	175-4598-00
A1M141	174-0385-00		CA ASSY,SP,ELEC:5,22 AWG,2.6 L,9-N	80009	174-0385-00
A1M918	195-3991-01		LEAD,ELECTRICAL:22 AWG,3.5 L,0-N	80009	195-3991-01
A1M919	195-3991-01		LEAD,ELECTRICAL:22 AWG,3.5 L,0-N	80009	195-3991-01
A1X100	136-0763-00		SKT,PL-IN ELEK:26 LINE CONT IMPD HYBRID	00779	ORDER BY DESC
A1X119	136-0728-00		SKT,PL-IN ELEK:MICROCKT,14 CONTACT	09922	01LB14P-108
A1X191	136-0263-07		SOCKET,PIN TERM:U/M 0.025 SQ PIN (QUANTITY OF 16)	22526	ORDER BY DESC
A1X200	136-0763-00		SKT,PL-IN ELEK:26 LINE CONT IMPD HYBRID	00779	ORDER BY DESC
A1X300	136-0764-00		SKT,PL-IN ELEK:48 LINE CONT IMPD HYBRID	00779	ORDER BY DESC
A1X400	136-0763-00		SKT,PL-IN ELEK:26 LINE CONT IMPD HYBRID	00779	ORDER BY DESC
A1X500	136-0764-00		SKT,PL-IN ELEK:48 LINE CONT IMPD HYBRID	00779	ORDER BY DESC
A1X600	136-0764-00		SKT,PL-IN ELEK:48 LINE CONT IMPD HYBRID	00779	ORDER BY DESC
A1X650	136-0757-00		SKT,PL-IN ELEK:MICROCKT,40 DIP	09922	01LB40P-108
A1X700	136-0764-00		SKT,PL-IN ELEK:48 LINE CONT IMPD HYBRID	00779	ORDER BY DESC
A1X900	136-0764-00		SKT,PL-IN ELEK:48 LINE CONT IMPD HYBRID	00779	ORDER BY DESC
A1X950	136-0764-00		SKT,PL-IN ELEK:48 LINE CONT IMPD HYBRID	00779	ORDER BY DESC
A2	672-1037-11		CIRCUIT 8D ASSY:LV PMR SPLY MODULE	80009	672-1037-11
A2A1	-----		CIRCUIT 8D ASSY:REGULATOR (AVAILABLE AT THE 672-1037-XX LEVEL ONLY)		
A2A1C1016	285-1222-00		CAP,FXD,PLASTIC:0.068UF,20%,250V	55112	158/.068/M/250/H
A2A1C1018	285-1222-00		CAP,FXD,PLASTIC:0.068UF,20%,250V	55112	158/.068/M/250/H
A2A1C1208	281-0775-00		CAP,FXD,CER OI:0.1UF,20%,50V	04222	MA205E104MAA
A2A1C1220	290-0939-00		CAP,FXD,ELCTLT:10UF,+100-10%,100V	56289	672D106H100CG2C
A2A1C1222	281-0783-00		CAP,FXD,CER OI:0.1 UF 20%,100V	04222	MA401C104MAA
A2A1C1226	281-0791-00		CAP,FXD,CER OI:270PF,10%,100V	04222	MA101C271KAA
A2A1C1240	290-0939-00		CAP,FXD,ELCTLT:10UF,+100-10%,100V	56289	672D106H100CG2C
A2A1C1245	281-0783-00		CAP,FXD,CER OI:0.1 UF 20%,100V	04222	MA401C104MAA

2455A Replaceable Electrical Parts
2445A/2455A Service

Component No.	Tektronix Part No.	Serial/Assembly No. Effective Decont	Name & Description	Mfr. Code	Mfr. Part No.
A2A1C1246	281-0791-00		CAP,FXD,CER DI:270PF,10%,100V	04222	MA101C271KAA
A2A1C1260	290-0942-00		CAP,FXD,ELCLTL:100UF,+100-10%,25V	55680	UPA1E101MAH
A2A1C1261	281-0773-00		CAP,FXD,CER DI:0.01UF,10%,100V	04222	MA201C103KAA
A2A1C1270	281-0791-00		CAP,FXD,CER DI:270PF,10%,100V	04222	MA101C271KAA
A2A1C1272	281-0774-00		CAP,FXD,CER DI:0.022MFD,20%,100V	04222	MA201E223MAA
A2A1C1280	290-0942-00		CAP,FXD,ELCLTL:100UF,+100-10%,25V	55680	UPA1E101MAH
A2A1C1290	281-0775-00		CAP,FXD,CER DI:0.1UF,20%,50V	04222	MA205E104MAA
A2A1C1291	290-0778-00		CAP,FXD,ELCLTL:1UF,+50 -10%,50V,NPLZO	54473	ECE-A50N1
A2A1C1300	290-0942-00		CAP,FXD,ELCLTL:100UF,+100-10%,25V	55680	UPA1E101MAH
A2A1C1330	290-0942-00		CAP,FXD,ELCLTL:100UF,+100-10%,25V	55680	UPA1E101MAH
A2A1C1331	281-0775-00		CAP,FXD,CER DI:0.1UF,20%,50V	04222	MA205E104MAA
A2A1C1350	290-0942-00		CAP,FXD,ELCLTL:100UF,+100-10%,25V	55680	UPA1E101MAH
A2A1C1357	281-0773-00		CAP,FXD,CER DI:0.01UF,10%,100V	04222	MA201C103KAA
A2A1C1374	281-0791-00		CAP,FXD,CER DI:270PF,10%,100V	04222	MA101C271KAA
A2A1C1400	290-0943-01		CAP,FXD,ELCLTL:47UF,20%,25V	55680	ULB1E470MPAANA1T
A2A1C1402	290-0943-01		CAP,FXD,ELCLTL:47UF,20%,25V	55680	ULB1E470MPAANA1T
A2A1C1974	290-0778-00		CAP,FXD,ELCLTL:1UF,+50 -10%,50V,NPLZO	54473	ECE-A50N1
A2A1CR1011	152-0750-00		SEMICOND DVC,DI:RECT BRDG,600V,3A,FAST RCVY	05828	RKBPC606-12
A2A1CR1220	152-0066-00		SEMICOND DVC,DI:RECT,SI,400V,1A,DO-41	05828	GP10G-020
A2A1CR1221	152-0066-00		SEMICOND DVC,DI:RECT,SI,400V,1A,DO-41	05828	GP10G-020
A2A1CR1241	152-0066-00		SEMICOND DVC,DI:RECT,SI,400V,1A,DO-41	05828	GP10G-020
A2A1CR1242	152-0066-00		SEMICOND DVC,DI:RECT,SI,400V,1A,DO-41	05828	GP10G-020
A2A1CR1243	152-0066-00		SEMICOND DVC,DI:RECT,SI,400V,1A,DO-41	05828	GP10G-020
A2A1CR1244	152-0066-00		SEMICOND DVC,DI:RECT,SI,400V,1A,DO-41	05828	GP10G-020
A2A1CR1260	152-0066-00		SEMICOND DVC,DI:RECT,SI,400V,1A,DO-41	05828	GP10G-020
A2A1CR1261	152-0066-00		SEMICOND DVC,DI:RECT,SI,400V,1A,DO-41	05828	GP10G-020
A2A1CR1262	152-0141-02		SEMICOND DVC,DI:SM,SI,30V,150MA,30V,DO-35	03508	0A2527 (1N4152)
A2A1CR1263	152-0141-02		SEMICOND DVC,DI:SM,SI,30V,150MA,30V,DO-35	03508	0A2527 (1N4152)
A2A1CR1264	152-0141-02		SEMICOND DVC,DI:SM,SI,30V,150MA,30V,DO-35	03508	0A2527 (1N4152)
A2A1CR1281	152-0141-02		SEMICOND DVC,DI:SM,SI,30V,150MA,30V,DO-35	03508	0A2527 (1N4152)
A2A1CR1282	152-0141-02		SEMICOND DVC,DI:SM,SI,30V,150MA,30V,DO-35	03508	0A2527 (1N4152)
A2A1CR1283	152-0066-00		SEMICOND DVC,DI:RECT,SI,400V,1A,DO-41	05828	GP10G-020
A2A1CR1300	152-0141-02		SEMICOND DVC,DI:SM,SI,30V,150MA,30V,DO-35	03508	0A2527 (1N4152)
A2A1CR1301	152-0141-02		SEMICOND DVC,DI:SM,SI,30V,150MA,30V,DO-35	03508	0A2527 (1N4152)
A2A1CR1302	152-0141-02		SEMICOND DVC,DI:SM,SI,30V,150MA,30V,DO-35	03508	0A2527 (1N4152)
A2A1CR1303	152-0066-00		SEMICOND DVC,DI:RECT,SI,400V,1A,DO-41	05828	GP10G-020
A2A1CR1330	152-0066-00		SEMICOND DVC,DI:RECT,SI,400V,1A,DO-41	05828	GP10G-020
A2A1CR1331	152-0066-00		SEMICOND DVC,DI:RECT,SI,400V,1A,DO-41	05828	GP10G-020
A2A1CR1332	152-0066-00		SEMICOND DVC,DI:RECT,SI,400V,1A,DO-41	05828	GP10G-020
A2A1CR1334	152-0066-00		SEMICOND DVC,DI:RECT,SI,400V,1A,DO-41	05828	GP10G-020
A2A1CR1351	152-0066-00		SEMICOND DVC,DI:RECT,SI,400V,1A,DO-41	05828	GP10G-020
A2A1CR1376	152-0141-02		SEMICOND DVC,DI:SM,SI,30V,150MA,30V,DO-35	03508	0A2527 (1N4152)
A2A1E1001	119-0181-00		ARSR,ELEC SURGE:230,GAS FILLED	25088	81-A230
A2A1E1002	119-0181-00		ARSR,ELEC SURGE:230,GAS FILLED	25088	81-A230
A2A1F1330	159-0185-00		FUSE,CARTRIDGE:5.2 X 20MM,0.75A,125V	TK0946	TSC-750MA
A2A1J121	131-0608-00		TERMINAL,PIN:0.365 L X 0.025 BRZ GLD PL (QUANTITY OF 6)	22526	48283-036
A2A1J122	131-0608-00		TERMINAL,PIN:0.365 L X 0.025 BRZ GLD PL (QUANTITY OF 7)	22526	48283-036
A2A1J201	131-0608-00		TERMINAL,PIN:0.365 L X 0.025 BRZ GLD PL (QUANTITY OF 4)	22526	48283-036
A2A1J202	131-0608-00		TERMINAL,PIN:0.365 L X 0.025 BRZ GLD PL (QUANTITY OF 4)	22526	48283-036
A2A1J203	131-2925-00		CONN,RCPT,ELEC:CKT BD,1 X 6,0.2 SPACING	27264	10-10-1064
A2A1J204	131-1048-00		TERM,QIK DISC.:CKT BD MT,0.11 X 0.02 BL	00779	61134-1
A2A1J205	131-1048-00		TERM,QIK DISC.:CKT BD MT,0.11 X 0.02 BL	00779	61134-1
A2A1J206	131-1048-00		TERM,QIK DISC.:CKT BD MT,0.11 X 0.02 BL	00779	61134-1
A2A1J207	131-1048-00		TERM,QIK DISC.:CKT BD MT,0.11 X 0.02 BL	00779	61134-1
A2A1L1011	108-0473-00		COIL,RF:FIXED,174UH	TK2042	ORDER BY OESCR

2455A Replaceable Electrical Parts
2445A/2455A Service

Component No.	Tektronix Part No.	Serial/Assembly No. Effective Decont	Name & Description	Mfr. Code	Mfr. Part No.
A2A1L1012	108-0473-00		COIL, RF: FIXED, 174UH	TK2042	ORDER BY DESCR
A2A1L1402	108-0443-00		COIL, RF: FIXED, 23.5UH	80009	108-0443-00
A2A1Q1220	151-0497-00		TRANSISTOR: NPN, SI, TO-220	04713	SJE1985
A2A1Q1221	151-0347-00		TRANSISTOR: NPN, SI, TO-92	04713	SPS7951
A2A1Q1222	151-0347-00		TRANSISTOR: NPN, SI, TO-92	04713	SPS7951
A2A1Q1223	151-0347-02		TRANSISTOR: NPN, SI, TO-92	56289	CT7916 (AMMOPACK)
A2A1Q1240	151-0464-00		TRANSISTOR: NPN, SI, TO-220	04713	SJE412
A2A1Q1241	151-0347-00		TRANSISTOR: NPN, SI, TO-92	04713	SPS7951
A2A1Q1243	151-0347-02		TRANSISTOR: NPN, SI, TO-92	56289	CT7916 (AMMOPACK)
A2A1Q1245	151-0347-00		TRANSISTOR: NPN, SI, TO-92	04713	SPS7951
A2A1Q1280	151-0476-00		TRANSISTOR: NPN, SI, TO-220AB	02735	68430
A2A1Q1281	151-0347-02		TRANSISTOR: NPN, SI, TO-92	56289	CT7916 (AMMOPACK)
A2A1Q1300	151-0482-00		TRANSISTOR: PNP, SI, TO-220	04713	SJE1977
A2A1Q1301	151-0342-00		TRANSISTOR: PNP, SI, TO-92	07263	S035928
A2A1Q1351	151-0429-00		TRANSISTOR: PNP, SI, TO-126	04713	SJE957
A2A1Q1354	151-0342-00		TRANSISTOR: PNP, SI, TO-92	07263	S035928
A2A1Q1370	151-0341-01		TRANSISTOR: PNP, SI, TO-92	04713	TO BE ASSIGNED
A2A1Q1376	151-0341-01		TRANSISTOR: PNP, SI, TO-92	04713	TO BE ASSIGNED
A2A1R1010	301-0150-00		RES, FXD, FILM: 15 OHM, 5%, 0.5M	19701	5053CX15R00J
A2A1R1011	315-0560-00		RES, FXD, FILM: 56 OHM, 5%, 0.25M	57668	NTR25J-E56E0
A2A1R1012	315-0560-00		RES, FXD, FILM: 56 OHM, 5%, 0.25M	57668	NTR25J-E56E0
A2A1R1013	315-0683-00		RES, FXD, FILM: 68K OHM, 5%, 0.25M	57668	NTR25J-E68K0
A2A1R1014	313-1363-00		RES, FXD, FILM: 36K OHM, 5%, 0.2M	57668	TR20JE 36K
A2A1R1015	313-1363-00		RES, FXD, FILM: 36K OHM, 5%, 0.2M	57668	TR20JE 36K
A2A1R1016	301-0680-00		RES, FXD, FILM: 68 OHM, 5%, 0.5M	19701	5053CX68R00J
A2A1R1017	313-1474-00		RES, FXD, FILM: 470K OHM, 5%, 0.2M	80009	313-1474-00
A2A1R1018	301-0300-00		RES, FXD, FILM: 30 OHM, 5%, 0.5M	19701	5053CX30R00J
A2A1R1019	301-0150-00		RES, FXD, FILM: 15 OHM, 5%, 0.5M	19701	5053CX15R00J
A2A1R1204	313-1103-00		RES, FXD, FILM: 10K OHM, 5%, 0.2M	57668	TR20JE10K0
A2A1R1208	313-1201-00		RES, FXD, FILM: 200 OHM, 5%, 0.2M	57668	TR20JE200E
A2A1R1212	313-1393-00		RES, FXD, FILM: 39K OHM, 5%, 0.2M	57668	TR20JE 39K
A2A1R1220	304-0822-00		RES, FXD, CMPSN: 8.2K OHM, 10%, 1M	01121	G88221
A2A1R1221	315-0100-02		RES, FXD, CMPSN: 10 OHM, 5%, 0.25M	01121	CB1005
A2A1R1222	313-1102-00		RES, FXD, FILM: 1K OHM, 5%, 0.2M	57668	TR20JED1K0
A2A1R1223	313-1823-00		RES, FXD, FILM: 82K OHM, 5%, 0.2M	57668	TR20JE 82K
A2A1R1226	313-1472-00		RES, FXD, FILM: 4.7K OHM, 5%, 0.2M	57668	TR20JE 04K7
A2A1R1227	321-0634-00		RES, FXD, FILM: 84.65K OHM, 0.25%, 0.125M, TC=T2	19701	5033RC84K65C
A2A1R1228	321-0293-03		RES, FXD, FILM: 11.0K OHM, 0.25%, 0.125M, TC=T2	24546	NC55C1102C
A2A1R1229	313-1683-00		RES, FXD, FILM: 68K OHM, 5%, 0.2M	57668	TR20JE 68K
A2A1R1240	303-0202-00		RES, FXD, CMPSN: 2K OHM, 5%, 1M	01121	G8 2025
A2A1R1241	307-0105-00		RES, FXD, CMPSN: 3.9 OHM, 5%, 0.25M	01121	CB 39G5
A2A1R1242	313-1152-00		RES, FXD, FILM: 1.5K OHM, 5%, 0.2M	57668	TR20JED1K5
A2A1R1243	313-1393-00		RES, FXD, FILM: 39K OHM, 5%, 0.2M	57668	TR20JE 39K
A2A1R1244	313-1104-00		RES, FXD, FILM: 100K OHM, 5%, 0.2M	57668	TR20JE100K
A2A1R1246	313-1472-00		RES, FXD, FILM: 4.7K OHM, 5%, 0.2M	57668	TR20JE 04K7
A2A1R1247	321-0368-00		RES, FXD, FILM: 66.5K OHM, 1%, 0.125M, TC=T0	07716	CEAD66501F
A2A1R1248	321-0319-00		RES, FXD, FILM: 20.5K OHM, 1%, 0.125M, TC=T0	19701	5033ED20K50F
A2A1R1249	313-1473-00		RES, FXD, FILM: 47K OHM, 5%, 0.2M	57668	TR20JE 47K
A2A1R1261	321-0289-00		RES, FXD, FILM: 10.0K OHM, 1%, 0.125M, TC=T0	19701	5033ED10K0F
A2A1R1262	321-0318-00		RES, FXD, FILM: 20.0K OHM, 1%, 0.125M, TC=T0	19701	5033ED20K00F
A2A1R1264	313-1473-00		RES, FXD, FILM: 47K OHM, 5%, 0.2M	57668	TR20JE 47K
A2A1R1270	313-1432-00		RES, FXD, FILM: 4.3K OHM, 5%, 0.2M	57668	TR20JE 04K3
A2A1R1273	313-1473-00		RES, FXD, FILM: 47K OHM, 5%, 0.2M	57668	TR20JE 47K
A2A1R1274	313-1683-00		RES, FXD, FILM: 68K OHM, 5%, 0.2M	57668	TR20JE 68K
A2A1R1280	303-0470-00		RES, FXD, CMPSN: 47 OHM, 5%, 1M	01121	G84705
A2A1R1281	308-0839-00		RES, FXD, MM: 0.1 OHM, 5%, 1.0M	75042	BM-20-R1000J
A2A1R1282	313-1102-00		RES, FXD, FILM: 1K OHM, 5%, 0.2M	57668	TR20JED1K0
A2A1R1283	313-1103-00		RES, FXD, FILM: 10K OHM, 5%, 0.2M	57668	TR20JE10K0
A2A1R1284	321-0318-00		RES, FXD, FILM: 20.0K OHM, 1%, 0.125M, TC=T0	19701	5033ED20K00F

2455A Replaceable Electrical Parts
2445A/2455A Service

Component No.	Tektronix Part No.	Serial/Assembly No. Effective Dscont	Name & Description	Mfr. Code	Mfr. Part No.
A2A1R1285	321-0318-00		RES, FXD, FILM:20.0K OHM, 1%, 0.125M, TC=T0	19701	5033ED20K00F
A2A1R1286	313-1243-00		RES, FXD, FILM:24K OHM, 5%, 0.2M	80009	313-1243-00
A2A1R1287	313-1472-00		RES, FXD, FILM:4.7K OHM, 5%, 0.2M	57668	TR20JE 04K7
A2A1R1291	321-0334-00		RES, FXD, FILM:29.4K OHM, 1%, 0.125M, TC=T0	07716	CEAD29401F
A2A1R1292	311-1138-00		RES, VAR, NONMM:TRMR, 1K OHM, 0.5M	32997	3386J-T07-102
A2A1R1293	321-0639-00		RES, FXD, FILM:9.6K OHM, 1%, 0.125M, TC=T0	19701	5043ED9K600F
A2A1R1300	303-0470-00		RES, FXD, CMPSN:47 OHM, 5%, 1M	01121	G84705
A2A1R1301	308-0839-00		RES, FXD, MM:0.1 OHM, 5%, 1.0M	75042	BM-20-R1000J
A2A1R1302	313-1102-00		RES, FXD, FILM:1K OHM, 5%, 0.2M	57668	TR20JE01K0
A2A1R1304	313-1243-00		RES, FXD, FILM:24K OHM, 5%, 0.2M	80009	313-1243-00
A2A1R1305	321-0289-06		RES, FXD, FILM:10.0K OHM, 0.25%, 0.125M, TC=T9	19701	5033RE10K00C
A2A1R1306	321-0318-03		RES, FXD, FILM:20.0K OHM, 0.125%, 0.125M, TC=T2	19701	5033RC20K00C
A2A1R1307	313-1472-00		RES, FXD, FILM:4.7K OHM, 5%, 0.2M	57668	TR20JE 04K7
A2A1R1309	313-1222-00		RES, FXD, FILM:2.2K OHM, 5%, 0.2M	57668	TR20JE 02K2
A2A1R1331	321-0685-00		RES, FXD, FILM:30K OHM, 0.5%, 0.125M, TC=T2	19701	5033RC30K00D
A2A1R1332	321-0318-03		RES, FXD, FILM:20.0K OHM, 0.125%, 0.125M, TC=T2	19701	5033RC20K00C
A2A1R1333	313-1751-00		RES, FXD, FILM:750 OHM, 5%, 0.2M	57668	TR20JE 750E
A2A1R1334	313-1103-00		RES, FXD, FILM:10K OHM, 5%, 0.2M	57668	TR20JE10K0
A2A1R1351	313-1202-00		RES, FXD, FILM:2K OHM, 5%, 0.2M	57668	TR20JE02K0
A2A1R1352	301-0150-00		RES, FXD, FILM:15 OHM, 5%, 0.5M	19701	5053CX15R00J
A2A1R1353	301-0150-00		RES, FXD, FILM:15 OHM, 5%, 0.5M	19701	5053CX15R00J
A2A1R1354	313-1222-00		RES, FXD, FILM:2.2K OHM, 5%, 0.2M	57668	TR20JE 02K2
A2A1R1355	313-1682-00		RES, FXD, FILM:6.8K OHM, 5%, 0.2M	57668	TR20JE 06K8
A2A1R1356	313-1512-00		RES, FXD, CMPSN:5.1K OHM, 5%, 0.2M	57668	TR20JE 5K1
A2A1R1357	321-0318-03		RES, FXD, FILM:20.0K OHM, 0.125%, 0.125M, TC=T2	19701	5033RC20K00C
A2A1R1358	321-0689-00		RES, FXD, FILM:24.9K OHM, 0.5%, 0.125M, TC=T0	19701	5033R024K90D
A2A1R1359	313-1682-00		RES, FXD, FILM:6.8K OHM, 5%, 0.2M	57668	TR20JE 06K8
A2A1R1370	321-0363-00		RES, FXD, FILM:59.0K OHM, 1%, 0.125M, TC=T0	07716	CEAD59001F
A2A1R1372	321-0299-00		RES, FXD, FILM:12.7K OHM, 1%, 0.125M, TC=T0	19701	5033ED12K70F
A2A1R1374	313-1103-00		RES, FXD, FILM:10K OHM, 5%, 0.2M	57668	TR20JE10K0
A2A1R1376	321-0318-03		RES, FXD, FILM:20.0K OHM, 0.125%, 0.125M, TC=T2	19701	5033RC20K00C
A2A1R1378	313-1202-00		RES, FXD, FILM:2K OHM, 5%, 0.2M	57668	TR20JE02K0
A2A1R1400	315-0101-03		RES, FXD, CMPSN:100 OHM, 5%, 0.25M	01121	C81015
A2A1R1402	315-0101-03		RES, FXD, CMPSN:100 OHM, 5%, 0.25M	01121	C81015
A2A1RT1010	307-0350-00		RES, THERMAL:7.5 OHM, 10%, 3.9%/DEG C	80009	307-0350-00
A2A1RT1016	307-0746-00		RES, THERMAL:5 OHM, 10%, 7A/DEG C	15454	SG200-S
A2A1S350	260-1848-00		SWITCH, PUSH:DPDT, 4A, 250VAC	31918	NE15/FZU103EE
A2A1T1229	120-1401-00		XFMR, TRIGGER:LINE, 1:1 TURNS RATIO	54937	DMI 500-2044
A2A1TP201	131-0608-00		TERMINAL, PIN:0.365 L X 0.025 BRZ GLD PL	22526	48283-036
A2A1U1260	156-1161-00		MICROCKT, LINEAR:VOLTAGE REGULATOR, PDS, ADJ	12969	UC317T
A2A1U1270	156-0495-02		MICROCKT, LINEAR:QUAD OPNL AMPL, SELECTED	01295	LM324J4
A2A1U1281	156-0158-07		MICROCKT, LINEAR:DUAL OPNL AMPL, SCREENED	01295	MC1458JG4
A2A1U1290	156-1173-00		MICROCKT, LINEAR:VOLTAGE REFERENCE	04713	MC1403UD5
A2A1U1300	156-0495-02		MICROCKT, LINEAR:QUAD OPNL AMPL, SELECTED	01295	LM324J4
A2A1U1330	156-0872-00		MICROCKT, LINEAR:VOLTAGE REGULATOR	04713	MC7912CT
A2A1U1371	156-0495-02		MICROCKT, LINEAR:QUAD OPNL AMPL, SELECTED	01295	LM324J4
A2A1VR1293	152-0055-00		SEMICOND DVC, DI:ZEN, SI, 11V, 5%, 0.4M, DO-7	14433	Z5407
A2A1M251	175-4585-00		CA ASSY, SP, ELEC:20, 28 AWG, 13.0 L	80009	175-4585-00
A3	-----		CIRCUIT BD ASSY:INVERTER (AVAILABLE AT THE 672-1037-XX LEVEL ONLY)		
A3C1020	285-1192-00		CAP, FXD, PPR DI:0.0022 UF, 20%, 250VAC	TK0515	PME271Y510
A3C1021	290-0971-00		CAP, FXD, ELCTLT:290UF +50-10%, 200V	56289	39DX1314
A3C1022	290-0971-00		CAP, FXD, ELCTLT:290UF +50-10%, 200V	56289	39DX1314
A3C1023	281-0773-00		CAP, FXD, CER DI:0.01UF, 10%, 100V	04222	MA201C103KAA
A3C1025	290-0942-00		CAP, FXD, ELCTLT:100UF, +100-10%, 25V	55680	UPA1E101MAH
A3C1032	281-0812-00		CAP, FXD, CER DI:1000PF, 10%, 100V	04222	MA101C102KAA

2455A Replaceable Electrical Parts
2445A/2455A Service

Component No.	Tektronix Part No.	Serial/Assembly No. Effective Decont	Name & Description	Mfr. Code	Mfr. Part No.
A3C1033	281-0772-00		CAP,FXD,CER DI:4700PF,10%,100V	04222	MA201C472KAA
A3C1034	290-0524-00		CAP,FXD,ELCTLT:4.7UF,20%,10V	05397	T368A475M010AZ
A3C1035	281-0772-00		CAP,FXD,CER DI:4700PF,10%,100V	04222	MA201C472KAA
A3C1040	281-0773-00		CAP,FXD,CER DI:0.01UF,10%,100V	04222	MA201C103KAA
A3C1048	281-0826-00		CAP,FXD,CER DI:2200PF,5%,100V	20932	401EM100AD222K
A3C1050	285-1254-00		CAP,FXD,PLASTIC:0.22UF,10%,400MVOC	56289	730P0167
A3C1051	285-1192-00		CAP,FXD,PPR DI:0.0022 UF,20%,250VAC	TK0515	PME271Y510
A3C1052	285-1196-00		CAP,FXD,PPR DI:0.01UF,20%,250V	TK0515	PME 265 M0 510
A3C1062	281-0850-00		CAP,FXD,CER DI:820PF,5%,50VDC	04222	MA101A821JAA
A3C1065	285-1190-00		CAP,FXD,MTLZD:0.056 UF,5%,250 V	05292	PMT3R ADVISE
A3C1066	290-0782-01		CAP,FXD,ELCTLT:4.7UF,20%,35VDC	55680	ULB1V4R7MPA1TD
A3C1067	281-0850-00		CAP,FXD,CER DI:820PF,5%,50VDC	04222	MA101A821JAA
A3C1071	281-0772-00		CAP,FXD,CER DI:4700PF,10%,100V	04222	MA201C472KAA
A3C1072	290-0806-00		CAP,FXD,ELCTLT:3.3UF,+75-10%,350VDC	55680	UNJ2V3R3TPA
A3C1075	283-0421-00		CAP,FXD,CER DI:0.1UF,+80-20%,50V	04222	ND015C104MAA
A3C1101	290-0942-00		CAP,FXD,ELCTLT:100UF,+100-10%,25V	55680	UPA1E101MAH
A3C1102	290-0942-00		CAP,FXD,ELCTLT:100UF,+100-10%,25V	55680	UPA1E101MAH
A3C1110	290-0800-00		CAP,FXD,ELCTLT:250UF,+100-10%,20V	56289	6720257H0200M5C
A3C1111	290-0800-00		CAP,FXD,ELCTLT:250UF,+100-10%,20V	56289	6720257H0200M5C
A3C1112	290-0782-01		CAP,FXD,ELCTLT:4.7UF,20%,35VDC	55680	ULB1V4R7MPA1TD
A3C1113	290-0798-00		CAP,FXD,ELCTLT:180UF,+100-10%,40V	56289	6720187H0400M5C
A3C1114	290-0800-00		CAP,FXD,ELCTLT:250UF,+100-10%,20V	56289	6720257H0200M5C
A3C1115	290-0800-00		CAP,FXD,ELCTLT:250UF,+100-10%,20V	56289	6720257H0200M5C
A3C1116	290-0798-00		CAP,FXD,ELCTLT:180UF,+100-10%,40V	56289	6720187H0400M5C
A3C1120	290-0939-00		CAP,FXD,ELCTLT:10UF,+100-10%,100V	56289	6720106H100CG2C
A3C1130	290-0939-00		CAP,FXD,ELCTLT:10UF,+100-10%,100V	56289	6720106H100CG2C
A3C1132	290-0880-00		CAP,FXD,ELCTLT:10UF,+50-10%,160V	54473	ECE-A160V10U
A3CR1022	152-0333-00		SEMICONO DVC,DI:SM,SI,55V,200MA,00-35	07263	FDH-6012
A3CR1023	152-0141-02		SEMICONO DVC,DI:SM,SI,30V,150MA,30V,00-35	03508	DA2527 (1M4152)
A3CR1028	152-0141-02		SEMICONO DVC,DI:SM,SI,30V,150MA,30V,00-35	03508	DA2527 (1M4152)
A3CR1030	152-0141-02		SEMICONO DVC,DI:SM,SI,30V,150MA,30V,00-35	03508	DA2527 (1M4152)
A3CR1034	152-0141-02		SEMICONO DVC,DI:SM,SI,30V,150MA,30V,00-35	03508	DA2527 (1M4152)
A3CR1035	152-0141-02		SEMICONO DVC,DI:SM,SI,30V,150MA,30V,00-35	03508	DA2527 (1M4152)
A3CR1040	152-0075-00		SEMICONO DVC,DI:SM,GE,22V,80MM,00-7	14433	G866
A3CR1050	152-0661-01		SEMICONO DVC,DI:RECT,SI,600V,3A,FAST RECOV	04713	S.R.3523-1RL
A3CR1060	152-0040-00		SEMICONO DVC,DI:RECT,SI,600V,1A,00-41	80009	152-0040-00
A3CR1062	152-0333-00		SEMICONO DVC,DI:SM,SI,55V,200MA,00-35	07263	FDH-6012
A3CR1063	152-0333-00		SEMICONO DVC,DI:SM,SI,55V,200MA,00-35	07263	FDH-6012
A3CR1064	152-0333-00		SEMICONO DVC,DI:SM,SI,55V,200MA,00-35	07263	FDH-6012
A3CR1065	152-0333-00		SEMICONO DVC,DI:SM,SI,55V,200MA,00-35	07263	FDH-6012
A3CR1070	152-0040-00		SEMICONO DVC,DI:RECT,SI,600V,1A,00-41	80009	152-0040-00
A3CR1072	152-0066-00		SEMICONO DVC,DI:RECT,SI,400V,1A,00-41	05828	GP10G-020
A3CR1101	152-0400-00		SEMICONO DVC,DI:RECT,SI,400V,1A	04713	SR1977K
A3CR1102	152-0400-00		SEMICONO DVC,DI:RECT,SI,400V,1A	04713	SR1977K
A3CR1103	152-0400-00		SEMICONO DVC,DI:RECT,SI,400V,1A	04713	SR1977K
A3CR1104	152-0400-00		SEMICONO DVC,DI:RECT,SI,400V,1A	04713	SR1977K
A3CR1105	152-0400-00		SEMICONO DVC,DI:RECT,SI,400V,1A	04713	SR1977K
A3CR1106	152-0400-00		SEMICONO DVC,DI:RECT,SI,400V,1A	04713	SR1977K
A3CR1110	152-0794-00		SEMICONO DVC,DI:RECT,SI,10A,30V,T0-220	81483	95-4269
A3CR1113	152-0946-00		SEMICONO DVC,DI:RECT,SI,40V,3.0A	80009	152-0946-00
A3CR1114	152-0946-00		SEMICONO DVC,DI:RECT,SI,40V,3.0A	80009	152-0946-00
A3CR1115	152-0946-00		SEMICONO DVC,DI:RECT,SI,40V,3.0A	80009	152-0946-00
A3CR1116	152-0946-00		SEMICONO DVC,DI:RECT,SI,40V,3.0A	80009	152-0946-00
A3CR1121	152-0400-00		SEMICONO DVC,DI:RECT,SI,400V,1A	04713	SR1977K
A3CR1122	152-0400-00		SEMICONO DVC,DI:RECT,SI,400V,1A	04713	SR1977K
A3CR1123	152-0400-00		SEMICONO DVC,DI:RECT,SI,400V,1A	04713	SR1977K
A3CR1124	152-0400-00		SEMICONO DVC,DI:RECT,SI,400V,1A	04713	SR1977K
A3CR1131	152-0400-00		SEMICONO DVC,DI:RECT,SI,400V,1A	04713	SR1977K
A3CR1132	152-0400-00		SEMICONO DVC,DI:RECT,SI,400V,1A	04713	SR1977K

2455A Replaceable Electrical Parts
2445A/2455A Service

Component No.	Tektronix Part No.	Serial/Assembly No. Effective Dscont	Name & Description	Mfr. Code	Mfr. Part No.
A3F1101	159-0255-00		FUSE,CARTRIDGE:FAST BLOW,4A,125V	80009	159-0255-00
A3F1102	159-0059-00		FUSE,WIRE LEAD:5A,125V	71400	A5
A3J301	131-0608-00		TERMINAL,PIN:0.365 L X 0.025 BRZ GLD PL (QUANTITY OF 3)	22526	48283-036
A3J302	131-0608-00		TERMINAL,PIN:0.365 L X 0.025 BRZ GLD PL (QUANTITY OF 3)	22526	48283-036
A3J303	131-2926-00		CONN,RCPT,ELEC:CKT B0,1 X 2,0.2 SPACING	27264	10-10-1024
A3L1110	108-0554-00		COIL,RF:FIXED,5UH,+/-20%	TK1345	108-0554-00
A3L1113	108-1144-00		COIL,RF:FIXED,27 UH,20%	34479	RL1284
A3L1114	108-1144-00		COIL,RF:FIXED,27 UH,20%	34479	RL1284
A3L1115	108-1144-00		COIL,RF:FIXED,27 UH,20%	34479	RL1284
A3L1116	108-1144-00		COIL,RF:FIXED,27 UH,20%	34479	RL1284
A3Q1021	151-0301-00		TRANSISTOR:PMP,SI,TO-18	04713	ST898
A3Q1022	151-0192-00		TRANSISTOR:SELECTED	04713	SPS8801
A3Q1029	151-0254-00		TRANSISTOR:DARLINGTON,NPN,SI	03508	X38L3118
A3Q1030	151-0301-00		TRANSISTOR:PMP,SI,TO-18	04713	ST898
A3Q1040	151-0302-00		TRANSISTOR:NPN,SI,TO-18	04713	ST899
A3Q1050	151-1152-00		TRANSISTOR:MOSFE,N-CHANNEL,SI,TO-220	04713	IRF820
A3Q1060	151-1152-00		TRANSISTOR:MOSFE,N-CHANNEL,SI,TO-220	04713	IRF820
A3Q1062	151-0302-00		TRANSISTOR:NPN,SI,TO-18	04713	ST899
A3Q1070	151-1152-00		TRANSISTOR:MOSFE,N-CHANNEL,SI,TO-220	04713	IRF820
A3Q1110	151-0188-00		TRANSISTOR:PMP,SI,TO-92	80009	151-0188-00
A3R1018	313-1394-00		RES,FXD,FILM:390K,5%,0.2M	57668	TR20JE 390K
A3R1019	313-1394-00		RES,FXD,FILM:390K,5%,0.2M	57668	TR20JE 390K
A3R1020	301-0274-00		RES,FXD,FILM:270K OHM,5%,0.5M	19701	5053CX270K0J
A3R1022	313-1104-00		RES,FXD,FILM:100K OHM,5%,0.2M	57668	TR20JE100K
A3R1023	313-1122-00		RES,FXD,FILM:1.2K OHM,5%,0.2M	57668	TR20JE01K2
A3R1024	313-1473-00		RES,FXD,FILM:47K OHM,5%,0.2M	57668	TR20JE 47K
A3R1025	313-1302-00		RES,FXD,FILM:3K OHM,5%,0.2M	57668	TR20JE 03K0
A3R1027	321-0431-00		RES,FXD,FILM:301K OHM,1%,0.125M,TC=TO	07716	CEA030102F
A3R1028	321-0481-04		RES,FXD,FILM:1M OHM,0.1%,0.125M,TC=T2	91637	CMF551160100038
A3R1029	313-1152-00		RES,FXD,FILM:1.5K OHM,5%,0.2M	57668	TR20JE01K5
A3R1030	313-1102-00		RES,FXD,FILM:1K OHM,5%,0.2M	57668	TR20JE01K0
A3R1031	313-1334-00		RES,FXD,FILM:330K OHM,5%,0.2M	80009	313-1334-00
A3R1032	321-0335-00		RES,FXD,FILM:30.1K OHM,1%,0.125M,TC=TO	57668	R814FXE30K1
A3R1033	313-1104-00		RES,FXD,FILM:100K OHM,5%,0.2M	57668	TR20JE100K
A3R1034	313-1102-00		RES,FXD,FILM:1K OHM,5%,0.2M	57668	TR20JE01K0
A3R1035	313-1103-00		RES,FXD,FILM:10K OHM,5%,0.2M	57668	TR20JE10K0
A3R1036	313-1103-00		RES,FXD,FILM:10K OHM,5%,0.2M	57668	TR20JE10K0
A3R1037	313-1272-00		RES,FXD,FILM:2.7K OHM,5%,0.2M	57668	TR20JE 02K7
A3R1040	313-1103-00		RES,FXD,FILM:10K OHM,5%,0.2M	57668	TR20JE10K0
A3R1041	313-1471-00		RES,FXD,FILM:470 OHM,5%,0.2M	57668	TR20JE 470E
A3R1042	313-1102-00		RES,FXD,FILM:1K OHM,5%,0.2M	57668	TR20JE01K0
A3R1044	321-0334-00		RES,FXD,FILM:29.4K OHM,1%,0.125M,TC=TO	07716	CEA029401F
A3R1045	321-0289-00		RES,FXD,FILM:10.0K OHM,1%,0.125M,TC=TO	19701	5033ED10K0F
A3R1046	321-0422-00		RES,FXD,FILM:243K OHM,1%,0.125M,TC=TO	07716	CEA024302F
A3R1050	308-0843-00		RES,FXD,MM:0.2 OHM,5%,1/0M	91637	RS1A-90-R2J
A3R1052	313-1470-00		RES,FXD,FILM:47 OHM,5%,0.2M	57668	TR20JE 47E
A3R1060	313-1470-00		RES,FXD,FILM:47 OHM,5%,0.2M	57668	TR20JE 47E
A3R1061	313-1202-00		RES,FXD,FILM:2K OHM,5%,0.2M	57668	TR20JE02K0
A3R1062	313-1682-00		RES,FXD,FILM:6.8K OHM,5%,0.2M	57668	TR20JE 06K8
A3R1063	313-1202-00		RES,FXD,FILM:2K OHM,5%,0.2M	57668	TR20JE02K0
A3R1064	313-1202-00		RES,FXD,FILM:2K OHM,5%,0.2M	57668	TR20JE02K0
A3R1065	315-0154-00		RES,FXD,FILM:150K OHM,5%,0.25M	57668	NTR25J-E150K
A3R1066	313-1202-00		RES,FXD,FILM:2K OHM,5%,0.2M	57668	TR20JE02K0
A3R1067	313-1682-00		RES,FXD,FILM:6.8K OHM,5%,0.2M	57668	TR20JE 06K8
A3R1068	313-1202-00		RES,FXD,FILM:2K OHM,5%,0.2M	57668	TR20JE02K0
A3R1069	303-0363-00		RES,FXD,CMPSM:36K OHM,5%,1M	01121	G83635
A3R1070	313-1470-00		RES,FXD,FILM:47 OHM,5%,0.2M	57668	TR20JE 47E

2455A Replaceable Electrical Parts
2445A/2455A Service

Component No.	Tektronix Part No.	Serial/Assembly No. Effective Dscont	Name & Description	Mfr. Code	Mfr. Part No.
A3R1071	315-0431-00		RES,FXD,FILM:430 OHM,5%,0.25M	19701	5043CX430R0J
A3R1072	321-0318-03		RES,FXD,FILM:20.0K OHM,0.125%,0.125M,TC=T2	19701	5033RC20K00C
A3R1075	313-1472-00		RES,FXD,FILM:4.7K OHM,5%,0.2M	57668	TR20JE 04K7
A3R1110	321-0219-00		RES,FXD,FILM:1.87K OHM,1%,0.125M,TC=TO	07716	CEAD18700F
A3R1111	315-0510-00		RES,FXD,FILM:51 OHM,5%,0.25M	19701	5043CX51R00J
A3R1112	321-0271-00		RES,FXD,FILM:6.49K OHM,1%,0.125M,TC=TO	07716	CEAD64900F
A3R1113	321-0271-00		RES,FXD,FILM:6.49K OHM,1%,0.125M,TC=TO	07716	CEAD64900F
A3R1114	321-0297-00		RES,FXD,FILM:12.1K OHM,1%,0.125M,TC=TO	07716	CEAD12101F
A3R1115	301-0301-00		RES,FXD,FILM:300 OHM,5%,0.5M	19701	5053CX300R0J
A3R1129	313-1474-00		RES,FXD,FILM:470K OHM,5%,0.2M	80009	313-1474-00
A3R1130	313-1273-00		RES,FXD,FILM:27K OHM,5%,0.2M	57668	TR20JE 27K
A3RL1060	108-0329-00		COIL,RF:FIXED,2,45UH	TK2042	ORDER BY OESCR
A3RT1110	307-0124-00		RES,THERMAL:5K OHM,10%,NTC	15454	10C502K-220-EC
A3S1020	260-0907-01		SWITCH,THRMSTC:NC,OP 97.8,CL 75.6,10A,240V	93410	430-1537
A3T1020	120-1244-00		TRANSFORMER,RF:COMMON MODE,13MH,0.5A	20462	4096
A3T1060	120-1437-00		XFMR,PMR,STPON:	02113	C1310
A3U1029	156-0885-05		CPLR,OPTOELECTR:LED,5KV,ISOLATION	09019	H11AX1139R
A3U1030	156-1627-00		MICROCKT,LINEAR:PULSE WIDTH MODULATED CONT CIRCUIT,SWITCHING POWER SUPPLY,SCRN	12969	UC494ACN
A3U1040	156-0885-05		CPLR,OPTOELECTR:LED,5KV,ISOLATION	09019	H11AX1139R
A3U1064	156-0366-02		MICROCKT,DGTL:DUAL 0 FLIP-FLOP,SCREENED	02735	CD40138FX
A3U1066	156-0328-00		MICROCKT,DGTL:DUAL MOS CLOCK DRIVER,SCRN	04713	MHW0026CP10
A3U1110	156-1161-00		MICROCKT,LINEAR:VOLTAGE REGULATOR,POS,ADJ	12969	UC317T
A3VR1020	152-0166-00		SEMICOND OVC,OI:ZEN,SI,6.2V,5%,0.4M,DO-7	04713	SZ11738RL
A3VR1062	152-0168-00		SEMICOND OVC,OI:ZEN,SI,12V,5%,0.4M,DO-7638	14552	T0331689
A3M1021	131-0566-00		BUS,COND:DUMMY RES,0.094 00 X 0.225L	24546	OMA 07
A3M1022	131-0566-00		BUS,COND:DUMMY RES,0.094 00 X 0.225L	24546	OMA 07
A3M1050	131-0566-00		BUS,COND:DUMMY RES,0.094 00 X 0.225L	24546	OMA 07
A3M1060	131-0566-00		BUS,COND:DUMMY RES,0.094 00 X 0.225L	24546	OMA 07
A3M1102	131-0566-00		BUS,COND:DUMMY RES,0.094 00 X 0.225L	24546	OMA 07
A3Y1050	120-1417-00		TRANSFORMER,RF:POWER HIGH FREQUENCY	54937	500-2311
A4	670-9493-00		CIRCUIT 80 ASSY:READOUT	80009	670-9493-00
A4C2830	281-0909-00		CAP,FXD,CER OI:0.022UF,20%,50V	54583	WA12X7R1H223M-T
A4C2835	281-0909-00		CAP,FXD,CER OI:0.022UF,20%,50V	54583	WA12X7R1H223M-T
A4C2851	281-0909-00		CAP,FXD,CER OI:0.022UF,20%,50V	54583	WA12X7R1H223M-T
A4C2855	281-0909-00		CAP,FXD,CER OI:0.022UF,20%,50V	54583	WA12X7R1H223M-T
A4C2860	281-0909-00		CAP,FXD,CER OI:0.022UF,20%,50V	54583	WA12X7R1H223M-T
A4C2885	281-0909-00		CAP,FXD,CER OI:0.022UF,20%,50V	54583	WA12X7R1H223M-T
A4C2901	281-0909-00		CAP,FXD,CER OI:0.022UF,20%,50V	54583	WA12X7R1H223M-T
A4C2911	281-0773-00		CAP,FXD,CER OI:0.01UF,10%,100V	04222	WA201C103KAA
A4C2913	281-0909-00		CAP,FXD,CER OI:0.022UF,20%,50V	54583	WA12X7R1H223M-T
A4C2926	281-0909-00		CAP,FXD,CER OI:0.022UF,20%,50V	54583	WA12X7R1H223M-T
A4C2940	281-0909-00		CAP,FXD,CER OI:0.022UF,20%,50V	54583	WA12X7R1H223M-T
A4C2950	281-0909-00		CAP,FXD,CER OI:0.022UF,20%,50V	54583	WA12X7R1H223M-T
A4C2960	281-0909-00		CAP,FXD,CER OI:0.022UF,20%,50V	54583	WA12X7R1H223M-T
A4C2970	281-0909-00		CAP,FXD,CER OI:0.022UF,20%,50V	54583	WA12X7R1H223M-T
A4C2980	281-0909-00		CAP,FXD,CER OI:0.022UF,20%,50V	54583	WA12X7R1H223M-T
A4C2990	281-0909-00		CAP,FXD,CER OI:0.022UF,20%,50V	54583	WA12X7R1H223M-T
A4R2805	313-1472-00		RES,FXD,FILM:4.7K OHM,5%,0.2M	57668	TR20JE 04K7
A4R2830	313-1101-00		RES,FXD,FILM:100 OHM,5%,0.2M	57668	TR20JE100E
A4R2841	313-1103-00		RES,FXD,FILM:10K OHM,5%,0.2M	57668	TR20JE10K0
A4R2842	313-1103-00		RES,FXD,FILM:10K OHM,5%,0.2M	57668	TR20JE10K0
A4R2843	313-1472-00		RES,FXD,FILM:4.7K OHM,5%,0.2M	57668	TR20JE 04K7
A4R2844	313-1472-00		RES,FXD,FILM:4.7K OHM,5%,0.2M	57668	TR20JE 04K7
A4R2850	313-1472-00		RES,FXD,FILM:4.7K OHM,5%,0.2M	57668	TR20JE 04K7
A4R2901	313-1103-00		RES,FXD,FILM:10K OHM,5%,0.2M	57668	TR20JE10K0

2455A Replaceable Electrical Parts
2445A/2455A Service

Component No.	Tektronix Part No.	Serial/Assembly No. Effective Dscont	Name & Description	Mfr. Code	Mfr. Part No.
A4R2902	313-1102-00		RES,FXD,FILM:1K OHM,5%,0.2M	57668	TR20JE01K0
A4R2903	321-1296-03		RES,FXD,FILM:12.0K OHM,0.25%,0.125M,TC=T2	07716	CEAC12001C
A4R2905	321-0816-03		RES,FXD,FILM:5K OHM,0.25%,0.125M,TC=T2	19701	5033RC5K000C
A4R2910	321-0685-00		RES,FXD,FILM:30K OHM,0.5%,0.125M,TC=T2	19701	5033RC30K000
A4R2911	321-0685-00		RES,FXD,FILM:30K OHM,0.5%,0.125M,TC=T2	19701	5033RC30K000
A4R2912	313-1102-00		RES,FXD,FILM:1K OHM,5%,0.2M	57668	TR20JE01K0
A4R2913	321-0198-00		RES,FXD,FILM:1.13K OHM,1%,0.125M,TC=T0	07716	CEAD11300F
A4R2914	321-0306-00		RES,FXD,FILM:15.0K OHM,1%,0.125M,TC=T0	19701	5033ED15J00F
A4R2915	313-1202-00		RES,FXD,FILM:2K OHM,5%,0.2M	57668	TR20JE02K0
A4R2916	322-3414-00		RES,FXD,FILM:200K OHM,1%,0.2M,TC=T0	91637	CCF50G20002F
A4R2917	322-3385-00		RES,FXD,FILM:100K OHM,1%,0.2M,TC=T0	57668	CRB20 FXE 100K
A4R2918	311-2270-00		RES,VAR,NONMM:TRMR,10K OHM,20%,0.5M	TK1450	GF06VT 10 K OHM
A4R2919	322-3385-00		RES,FXD,FILM:100K OHM,1%,0.2M,TC=T0	57668	CRB20 FXE 100K
A4R2920	313-1334-00		RES,FXD,FILM:330K OHM,5%,0.2M	80009	313-1334-00
A4R2921	321-0724-03		RES,FXD,FILM:13.6K OHM,0.125%,0.125M,TC=T2	24546	NC55C1362C
A4R2922	321-0756-00		RES,FXD,FILM:50K OHM,1%,0.125M,TC=T0	24546	NA550S002F
A4R2923	321-0385-00		RES,FXD,FILM:100K OHM,1%,0.125M,TC=T0	19701	5033ED100K0F
A4R2924	321-0414-00		RES,FXD,FILM:200K OHM,1%,0.125M,TC=T0	07716	CEA020002F
A4R2925	321-0235-02		RES,FXD,FILM:2.74K OHM,0.5%,0.125M,TC=T2	24546	NC55C27410
A4R2926	322-3214-00		RES,FXD,FILM:1.65K OHM,1%,0.2M,TC=T0	57668	CRB 20 FXE 1K65
A4R2927	313-1203-00		RES,FXD,FILM:20K OHM,5%,0.2M	57668	TR20JE20K
A4R2928	313-1472-00		RES,FXD,FILM:4.7K OHM,5%,0.2M	57668	TR20JE 04K7
A4R2929	313-1472-00		RES,FXD,FILM:4.7K OHM,5%,0.2M	57668	TR20JE 04K7
A4R2930	313-1152-00		RES,FXD,FILM:1.5K OHM,5%,0.2M	57668	TR20JE01K5
A4R2931	311-2258-00		RES,VAR,NONMM:TRMR,1K OHM,20%,0.5M	TK1450	GF06VT 1 K OHM
A4R2932	322-3414-00		RES,FXD,FILM:200K OHM,1%,0.2M,TC=T0	91637	CCF50G20002F
A4R2933	322-3385-00		RES,FXD,FILM:100K OHM,1%,0.2M,TC=T0	57668	CRB20 FXE 100K
A4R2940	313-1102-00		RES,FXD,FILM:1K OHM,5%,0.2M	57668	TR20JE01K0
A4R2945	313-1471-00		RES,FXD,FILM:470 OHM,5%,0.2M	57668	TR20JE 470E
A4R2975	313-1472-00		RES,FXD,FILM:4.7K OHM,5%,0.2M	57668	TR20JE 04K7
A4R2985	313-1102-00		RES,FXD,FILM:1K OHM,5%,0.2M	57668	TR20JE01K0
A4U2800	156-0514-01		MICROCKT,DGTL:DIFF 4-CHANNEL MUX,SEL	80009	156-0514-01
A4U2805	156-0514-01		MICROCKT,DGTL:DIFF 4-CHANNEL MUX,SEL	80009	156-0514-01
A4U2810	156-0382-02		MICROCKT,DGTL:QUAD 2 INP NAND GATE BURN	18324	N74LS00NB
A4U2820	156-1191-01		MICROCKT,LINEAR:DUAL BI-FET OP-AMP,8 DIP	80009	156-1191-01
A4U2830	156-1172-01		MICROCKT,DGTL:DUAL 4 BIT BIN CNTR	01295	SN74LS393NP3
A4U2835	156-0479-02		MICROCKT,DGTL:QUAD 2-INP OR GATE	01295	SN74LS32NP3
A4U2850	156-0388-03		MICROCKT,DGTL:DUAL D FLIP-FLOP	01295	SN74LS74ANP3
A4U2855	156-0383-02		MICROCKT,DGTL:QUAD 2-INP NOR GATE	18324	N74LS02NB
A4U2860	156-0975-02		MICROCKT,DGTL:UNIV SHIFT/STORAGE REGISTER	34335	DM74LS299N-8
A4U2865	156-0796-01		MICROCKT,DGTL:8 STG SHF & STORE BUS RGTR	02735	CD40948FX
A4U2870	156-1172-01		MICROCKT,DGTL:DUAL 4 BIT BIN CNTR	01295	SN74LS393NP3
A4U2880	156-0388-03		MICROCKT,DGTL:DUAL D FLIP-FLOP	01295	SN74LS74ANP3
A4U2885	156-0386-02		MICROCKT,DGTL:TRIPLE 3-INP NAND GATE	07263	74LS10PCQR
A4U2890	156-0382-02		MICROCKT,DGTL:QUAD 2 INP NAND GATE BURN	18324	N74LS00NB
A4U2900	156-0386-02		MICROCKT,DGTL:TRIPLE 3-INP NAND GATE	07263	74LS10PCQR
A4U2905	156-0982-03		MICROCKT,DGTL:OCTAL-D-EDGE TRIG FF	01295	SN74LS374N3
A4U2910	156-1555-00		MICROCKT,LINEAR:D/A CONVERTER	34335	AM6080PC
A4U2920	156-1594-00		MICROCKT,DGTL:NMOS,2048 X 8 SRAM	TK1015	HM6116P-3(OP-24)
A4U2930	160-1631-02		MICROCKT,DGTL:4096 X 8 EPROM,PRGM	80009	160-1631-02
A4U2935	156-0956-02		MICROCKT,DGTL:OCTAL BFR M/3 STATE OUT	01295	SN74LS24ANP3
A4U2940	156-1172-01		MICROCKT,DGTL:DUAL 4 BIT BIN CNTR	01295	SN74LS393NP3
A4U2950	156-0388-03		MICROCKT,DGTL:DUAL D FLIP-FLOP	01295	SN74LS74ANP3
A4U2960	156-0796-01		MICROCKT,DGTL:8 STG SHF & STORE BUS RGTR	02735	CD40948FX
A4U2965	156-0382-02		MICROCKT,DGTL:QUAD 2 INP NAND GATE BURN	18324	N74LS00NB
A4U2970	156-0480-02		MICROCKT,DGTL:QUAD 2-INP & GATE	01295	SN74LS08NP3
A4U2980	156-0382-02		MICROCKT,DGTL:QUAD 2 INP NAND GATE BURN	18324	N74LS00NB
A4U2985	156-0768-01		MICROCKT,DGTL:BI-DIRECT UNIV SR,SCREENED	01295	SN74LS194ANP3
A4U2990	156-0381-02		MICROCKT,DGTL:QUAD 2-INP EXCL OR GATE	07263	74LS86PCQR

2455A Replaceable Electrical Parts
2445A/2455A Service

Component No.	Tektronix Part No.	Serial/Assembly No. Effective	Discont	Name & Description	Mfr. Code	Mfr. Part No.
A4U2995	156-0651-02			MICROCKT,OGTL:8-BIT PRL-OUT SER SHF RGTR	01295	SN74LS164NP3
A4VR2805	152-0217-00			SEMICONO OVC,DI:ZEN,S1,8.2V,5%,0.4M,00-7	04713	SZG20
A4VR2925	152-0662-00			SEMICONO OVC,DI:ZEN,S1,5V,1%,400MM,00-7	04713	SZG195RL
A4M411	175-4581-01			CA ASSY,SP,ELEC:26,28 AMG,2.25 L,RIBBON	22526	ORDER BY DESC
A4M2851	131-0566-00			BUS,COND:DUMMY RES,0.094 00 X 0.225L	24546	OMA 07
A4M2913	131-0566-00			BUS,COND:DUMMY RES,0.094 00 X 0.225L	24546	OMA 07
A5	670-9052-00			CIRCUIT 80 ASSY:DIGITAL CONTROL	80009	670-9052-00
A5BT2570	146-0049-00			BATTERY,STORAGE:3.5V,750MAH	81855	LTC-7P
A5C2010	290-0943-01			CAP,FXD,ELCTLT:47UF,20%,25V	55680	ULB1E470MPAANA1T
A5C2011	290-0943-01			CAP,FXD,ELCTLT:47UF,20%,25V	55680	ULB1E470MPAANA1T
A5C2101	281-0909-00			CAP,FXD,CER DI:0.022UF,20%,50V	54583	MA12X7R1H223M-T
A5C2110	281-0814-00			CAP,FXD,CER DI:100 PF,10%,100V	04222	MA101A101KAA
A5C2111	281-0909-00			CAP,FXD,CER DI:0.022UF,20%,50V	54583	MA12X7R1H223M-T
A5C2112	281-0909-00			CAP,FXD,CER DI:0.022UF,20%,50V	54583	MA12X7R1H223M-T
A5C2113	290-0943-01			CAP,FXD,ELCTLT:47UF,20%,25V	55680	ULB1E470MPAANA1T
A5C2160	281-0909-00			CAP,FXD,CER DI:0.022UF,20%,50V	54583	MA12X7R1H223M-T
A5C2220	281-0909-00			CAP,FXD,CER DI:0.022UF,20%,50V	54583	MA12X7R1H223M-T
A5C2221	281-0909-00			CAP,FXD,CER DI:0.022UF,20%,50V	54583	MA12X7R1H223M-T
A5C2230	281-0909-00			CAP,FXD,CER DI:0.022UF,20%,50V	54583	MA12X7R1H223M-T
A5C2240	281-0909-00			CAP,FXD,CER DI:0.022UF,20%,50V	54583	MA12X7R1H223M-T
A5C2320	281-0909-00			CAP,FXD,CER DI:0.022UF,20%,50V	54583	MA12X7R1H223M-T
A5C2321	285-1301-01			CAP,FXD,MTLZD:0.47UF,10%,50V	55112	1850.47K50A8B
A5C2322	285-1348-00			CAP,FXD,MTLZD:0.22UF,10%,63V	55112	1850.22K63A8B
A5C2330	285-1301-01			CAP,FXD,MTLZD:0.47UF,10%,50V	55112	1850.47K50A8B
A5C2331	285-1348-00			CAP,FXD,MTLZD:0.22UF,10%,63V	55112	1850.22K63A8B
A5C2332	285-1300-01			CAP,FXD,MTLZD:0.1UF,10%,63V	55112	185/0.1/K/63/ABA
A5C2333	285-1300-01			CAP,FXD,MTLZD:0.1UF,10%,63V	55112	185/0.1/K/63/ABA
A5C2340	281-0909-00			CAP,FXD,CER DI:0.022UF,20%,50V	54583	MA12X7R1H223M-T
A5C2350	290-0527-00			CAP,FXD,ELCTLT:15UF,20%,20V	05397	T3688156M020AS
A5C2351	281-0909-00			CAP,FXD,CER DI:0.022UF,20%,50V	54583	MA12X7R1H223M-T
A5C2360	281-0909-00			CAP,FXD,CER DI:0.022UF,20%,50V	54583	MA12X7R1H223M-T
A5C2420	290-0943-01			CAP,FXD,ELCTLT:47UF,20%,25V	55680	ULB1E470MPAANA1T
A5C2421	285-1300-01			CAP,FXD,MTLZD:0.1UF,10%,63V	55112	185/0.1/K/63/ABA
A5C2422	281-0791-00			CAP,FXD,CER DI:270PF,10%,100V	04222	MA101C271KAA
A5C2430	285-1301-01			CAP,FXD,MTLZD:0.47UF,10%,50V	55112	1850.47K50A8B
A5C2431	285-1348-00			CAP,FXD,MTLZD:0.22UF,10%,63V	55112	1850.22K63A8B
A5C2432	285-1348-00			CAP,FXD,MTLZD:0.22UF,10%,63V	55112	1850.22K63A8B
A5C2450	281-0909-00			CAP,FXD,CER DI:0.022UF,20%,50V	54583	MA12X7R1H223M-T
A5C2470	290-0527-00			CAP,FXD,ELCTLT:15UF,20%,20V	05397	T3688156M020AS
A5C2501	281-0909-00			CAP,FXD,CER DI:0.022UF,20%,50V	54583	MA12X7R1H223M-T
A5C2510	281-0909-00			CAP,FXD,CER DI:0.022UF,20%,50V	54583	MA12X7R1H223M-T
A5C2511	281-0791-00			CAP,FXD,CER DI:270PF,10%,100V	04222	MA101C271KAA
A5C2520	281-0909-00			CAP,FXD,CER DI:0.022UF,20%,50V	54583	MA12X7R1H223M-T
A5C2521	281-0909-00			CAP,FXD,CER DI:0.022UF,20%,50V	54583	MA12X7R1H223M-T
A5C2530	281-0909-00			CAP,FXD,CER DI:0.022UF,20%,50V	54583	MA12X7R1H223M-T
A5C2550	281-0819-00			CAP,FXD,CER DI:33 PF,5%,50V	04222	GC105A330J
A5C2551	281-0816-00			CAP,FXD,CER DI:82 PF,5%,100V	04222	MA106A820JAA
A5C2552	281-0909-00			CAP,FXD,CER DI:0.022UF,20%,50V	54583	MA12X7R1H223M-T
A5C2601	281-0909-00			CAP,FXD,CER DI:0.022UF,20%,50V	54583	MA12X7R1H223M-T
A5C2610	281-0909-00			CAP,FXD,CER DI:0.022UF,20%,50V	54583	MA12X7R1H223M-T
A5C2620	281-0909-00			CAP,FXD,CER DI:0.022UF,20%,50V	54583	MA12X7R1H223M-T
A5C2621	285-1300-01			CAP,FXD,MTLZD:0.1UF,10%,63V	55112	185/0.1/K/63/ABA
A5C2622	285-1348-00			CAP,FXD,MTLZD:0.22UF,10%,63V	55112	1850.22K63A8B
A5C2630	285-1300-01			CAP,FXD,MTLZD:0.1UF,10%,63V	55112	185/0.1/K/63/ABA
A5C2631	285-1348-00			CAP,FXD,MTLZD:0.22UF,10%,63V	55112	1850.22K63A8B
A5C2632	281-0909-00			CAP,FXD,CER DI:0.022UF,20%,50V	54583	MA12X7R1H223M-T

2455A Replaceable Electrical Parts
2445A/2455A Service

Component No.	Tektronix Part No.	Serial/Assembly No. Effective Dscont	Name & Description	Mfr. Code	Mfr. Part No.
A5C2640	285-1300-01		CAP,FXD,MTLZD:0.1UF,10%,63V	55112	185/0.1/K/63/AB4
A5C2650	281-0909-00		CAP,FXD,CER DI:0.022UF,20%,50V	54583	MA12X7R1H223M-T
A5C2660	281-0909-00		CAP,FXD,CER DI:0.022UF,20%,50V	54583	MA12X7R1H223M-T
A5C2720	285-1301-01		CAP,FXD,MTLZD:0.47UF,10%,50V	55112	1850.47K50A8B
A5C2721	285-1348-00		CAP,FXD,MTLZD:0.22UF,10%,63V	55112	1850.22K63A8B
A5C2730	285-1348-00		CAP,FXD,MTLZD:0.22UF,10%,63V	55112	1850.22K63A8B
A5C2731	285-1301-01		CAP,FXD,MTLZD:0.47UF,10%,50V	55112	1850.47K50A8B
A5C2732	285-1301-01		CAP,FXD,MTLZD:0.47UF,10%,50V	55112	1850.47K50A8B
A5C2733	285-1301-01		CAP,FXD,MTLZD:0.47UF,10%,50V	55112	1850.47K50A8B
A5C2740	281-0909-00		CAP,FXD,CER DI:0.022UF,20%,50V	54583	MA12X7R1H223M-T
A5C2800	281-0812-00		CAP,FXD,CER DI:1000PF,10%,100V	04222	MA101C102KAA
A5CR2070	152-0141-02		SEMICON DVC,DI:SM,SI,30V,150MA,30V,DO-35	03508	DA2527 (1N4152)
A5CR2071	152-0141-02		SEMICON DVC,DI:SM,SI,30V,150MA,30V,DO-35	03508	DA2527 (1N4152)
A5CR2170	152-0141-02		SEMICON DVC,DI:SM,SI,30V,150MA,30V,DO-35	03508	DA2527 (1N4152)
A5CR2230	152-0141-02		SEMICON DVC,DI:SM,SI,30V,150MA,30V,DO-35	03508	DA2527 (1N4152)
A5CR2231	152-0141-02		SEMICON DVC,DI:SM,SI,30V,150MA,30V,DO-35	03508	DA2527 (1N4152)
A5CR2232	152-0141-02		SEMICON DVC,DI:SM,SI,30V,150MA,30V,DO-35	03508	DA2527 (1N4152)
A5CR2233	152-0141-02		SEMICON DVC,DI:SM,SI,30V,150MA,30V,DO-35	03508	DA2527 (1N4152)
A5CR2370	152-0322-00		SEMICON DVC,DI:SCHOTTKY BARRIER,SI,15V	50434	5082-2672
A5CR2371	152-0322-00		SEMICON DVC,DI:SCHOTTKY BARRIER,SI,15V	50434	5082-2672
A5CR2420	152-0141-02		SEMICON DVC,DI:SM,SI,30V,150MA,30V,DO-35	03508	DA2527 (1N4152)
A5CR2610	152-0141-02		SEMICON DVC,DI:SM,SI,30V,150MA,30V,DO-35	03508	DA2527 (1N4152)
A5CR2620	152-0141-02		SEMICON DVC,DI:SM,SI,30V,150MA,30V,DO-35	03508	DA2527 (1N4152)
A5CR2621	152-0141-02		SEMICON DVC,DI:SM,SI,30V,150MA,30V,DO-35	03508	DA2527 (1N4152)
A5CR2622	152-0141-02		SEMICON DVC,DI:SM,SI,30V,150MA,30V,DO-35	03508	DA2527 (1N4152)
A5CR2630	152-0141-02		SEMICON DVC,DI:SM,SI,30V,150MA,30V,DO-35	03508	DA2527 (1N4152)
A5CR2631	152-0141-02		SEMICON DVC,DI:SM,SI,30V,150MA,30V,DO-35	03508	DA2527 (1N4152)
A5CR2640	152-0141-02		SEMICON DVC,DI:SM,SI,30V,150MA,30V,DO-35	03508	DA2527 (1N4152)
A5CR2770	152-0322-00		SEMICON DVC,DI:SCHOTTKY BARRIER,SI,15V	50434	5082-2672
A5J251	131-3360-00		CONN,RCPT,ELEC:HEADER,RTANG,20 PIN	53387	3592-6002
A5J500	131-3364-00		CONN,RCPT,ELEC:HEADER,STRAIGHT,34 PIN	53387	3594-6002
A5J501	131-0608-00		TERMINAL,PIN:0.365 L X 0.025 BRZ GLD PL (QUANTITY OF 3)	22526	48283-036
A5J503	131-0608-00		TERMINAL,PIN:0.365 L X 0.025 BRZ GLD PL (QUANTITY OF 3)	22526	48283-036
A5J651	131-3360-00		CONN,RCPT,ELEC:HEADER,RTANG,20 PIN	53387	3592-6002
A5J652	131-3360-00		CONN,RCPT,ELEC:HEADER,RTANG,20 PIN	53387	3592-6002
A5Q2070	151-0342-00		TRANSISTOR:PMP,SI,TO-92	07263	5035928
A5Q2270	151-0342-00		TRANSISTOR:PMP,SI,TO-92	07263	5035928
A5Q2320	151-0341-01		TRANSISTOR:PMP,SI,TO-92	04713	TO BE ASSIGNED
A5R2001	313-1101-00		RES,FXD,FILM:100 OHM,5%,0.2M	57668	TR20JE100E
A5R2002	313-1101-00		RES,FXD,FILM:100 OHM,5%,0.2M	57668	TR20JE100E
A5R2004	313-1101-00		RES,FXD,FILM:100 OHM,5%,0.2M	57668	TR20JE100E
A5R2005	313-1101-00		RES,FXD,FILM:100 OHM,5%,0.2M	57668	TR20JE100E
A5R2006	313-1101-00		RES,FXD,FILM:100 OHM,5%,0.2M	57668	TR20JE100E
A5R2007	313-1101-00		RES,FXD,FILM:100 OHM,5%,0.2M	57668	TR20JE100E
A5R2010	311-2234-00		RES,VAR,MONOM:TRMR,5K OHM,20%,0.5M	TK1450	GF06UT 5K
A5R2011	322-3431-00		RES,FXD,FILM:301K OHM,1%,0.2M,TC=TO	57668	CR820 FXE 301K
A5R2012	322-3289-02		RES,FXD,FILM:10K OHM,0.5%,0.2M,TC=T2	57668	CR8 20 DYE 10K0
A5R2013	322-3289-02		RES,FXD,FILM:10K OHM,0.5%,0.2M,TC=T2	57668	CR8 20 DYE 10K0
A5R2101	313-1101-00		RES,FXD,FILM:100 OHM,5%,0.2M	57668	TR20JE100E
A5R2102	313-1101-00		RES,FXD,FILM:100 OHM,5%,0.2M	57668	TR20JE100E
A5R2103	313-1101-00		RES,FXD,FILM:100 OHM,5%,0.2M	57668	TR20JE100E
A5R2104	313-1101-00		RES,FXD,FILM:100 OHM,5%,0.2M	57668	TR20JE100E
A5R2110	313-1103-00		RES,FXD,FILM:10K OHM,5%,0.2M	57668	TR20JE10K0
A5R2170	313-1512-00		RES,FXD,CMPSN:5.1K OHM,5%,0.2M	57668	TR20JE 5K1
A5R2170	322-3235-00		RES,FXD,FILM:2.74K OHM,1%,0.2M,TC=TO	57668	CR820 FXE 2K74
A5R2171	313-1102-00		RES,FXD,FILM:1K OHM,5%,0.2M	57668	TR20JED1K0
A5R2172	313-1102-00		RES,FXD,FILM:1K OHM,5%,0.2M	57668	TR20JED1K0

2455A Replaceable Electrical Parts
2445A/2455A Service

Component No.	Tektronix Part No.	Serial/Assembly No. Effective Dscont	Name & Description	Mfr. Code	Mfr. Part No.
A5R2201	313-1103-00		RES, FXD, FILM: 10K OHM, 5%, 0.2M	57668	TR20JE10K0
A5R2202	313-1103-00		RES, FXD, FILM: 10K OHM, 5%, 0.2M	57668	TR20JE10K0
A5R2203	313-1103-00		RES, FXD, FILM: 10K OHM, 5%, 0.2M	57668	TR20JE10K0
A5R2204	313-1103-00		RES, FXD, FILM: 10K OHM, 5%, 0.2M	57668	TR20JE10K0
A5R2205	313-1103-00		RES, FXD, FILM: 10K OHM, 5%, 0.2M	57668	TR20JE10K0
A5R2206	313-1103-00		RES, FXD, FILM: 10K OHM, 5%, 0.2M	57668	TR20JE10K0
A5R2220	313-1102-00		RES, FXD, FILM: 1K OHM, 5%, 0.2M	57668	TR20JED1K0
A5R2230	322-3482-02		RES, FXD, FILM: 14.2K OHM, 0.5%, 0.2M, TC=T0	57668	CR8 20 DYE 14K2
A5R2231	313-1102-00		RES, FXD, FILM: 1K OHM, 5%, 0.2M	57668	TR20JED1K0
A5R2232	313-1102-00		RES, FXD, FILM: 1K OHM, 5%, 0.2M	57668	TR20JED1K0
A5R2240	313-1103-00		RES, FXD, FILM: 10K OHM, 5%, 0.2M	57668	TR20JE10K0
A5R2241	313-1104-00		RES, FXD, FILM: 100K OHM, 5%, 0.2M	57668	TR20JE100K
A5R2242	313-1104-00		RES, FXD, FILM: 100K OHM, 5%, 0.2M	57668	TR20JE100K
A5R2243	313-1103-00		RES, FXD, FILM: 10K OHM, 5%, 0.2M	57668	TR20JE10K0
A5R2244	313-1103-00		RES, FXD, FILM: 10K OHM, 5%, 0.2M	57668	TR20JE10K0
A5R2250	313-1102-00		RES, FXD, FILM: 1K OHM, 5%, 0.2M	57668	TR20JED1K0
A5R2251	313-1102-00		RES, FXD, FILM: 1K OHM, 5%, 0.2M	57668	TR20JED1K0
A5R2301	313-1103-00		RES, FXD, FILM: 10K OHM, 5%, 0.2M	57668	TR20JE10K0
A5R2302	313-1103-00		RES, FXD, FILM: 10K OHM, 5%, 0.2M	57668	TR20JE10K0
A5R2303	313-1103-00		RES, FXD, FILM: 10K OHM, 5%, 0.2M	57668	TR20JE10K0
A5R2304	313-1103-00		RES, FXD, FILM: 10K OHM, 5%, 0.2M	57668	TR20JE10K0
A5R2305	313-1103-00		RES, FXD, FILM: 10K OHM, 5%, 0.2M	57668	TR20JE10K0
A5R2306	313-1103-00		RES, FXD, FILM: 10K OHM, 5%, 0.2M	57668	TR20JE10K0
A5R2320	313-1203-00		RES, FXD, FILM: 20K OHM, 5%, 0.2M	57668	TR20JE20K
A5R2330	322-3360-02		RES, FXD, FILM: 54.9K OHM, 0.5%, 0.2M, TC=T2	57668	CR820 DYE 54K9
A5R2331	322-3235-00		RES, FXD, FILM: 2.74K OHM, 1%, 0.2M, TC=T0	57668	CR820 FXE 2K74
A5R2332	322-3193-00		RES, FXD, FILM: 1K OHM, 1%, 0.2M, TC=T0	57668	CR820 FXE 1K00
A5R2333	322-3235-00		RES, FXD, FILM: 2.74K OHM, 1%, 0.2M, TC=T0	57668	CR820 FXE 2K74
A5R2334	322-3193-00		RES, FXD, FILM: 1K OHM, 1%, 0.2M, TC=T0	57668	CR820 FXE 1K00
A5R2340	313-1103-00		RES, FXD, FILM: 10K OHM, 5%, 0.2M	57668	TR20JE10K0
A5R2341	313-1103-00		RES, FXD, FILM: 10K OHM, 5%, 0.2M	57668	TR20JE10K0
A5R2342	313-1103-00		RES, FXD, FILM: 10K OHM, 5%, 0.2M	57668	TR20JE10K0
A5R2343	313-1104-00		RES, FXD, FILM: 100K OHM, 5%, 0.2M	57668	TR20JE100K
A5R2344	313-1104-00		RES, FXD, FILM: 100K OHM, 5%, 0.2M	57668	TR20JE100K
A5R2345	313-1102-00		RES, FXD, FILM: 1K OHM, 5%, 0.2M	57668	TR20JED1K0
A5R2346	313-1103-00		RES, FXD, FILM: 10K OHM, 5%, 0.2M	57668	TR20JE10K0
A5R2370	313-1102-00		RES, FXD, FILM: 1K OHM, 5%, 0.2M	57668	TR20JED1K0
A5R2401	313-1103-00		RES, FXD, FILM: 10K OHM, 5%, 0.2M	57668	TR20JE10K0
A5R2402	313-1103-00		RES, FXD, FILM: 10K OHM, 5%, 0.2M	57668	TR20JE10K0
A5R2403	313-1103-00		RES, FXD, FILM: 10K OHM, 5%, 0.2M	57668	TR20JE10K0
A5R2404	313-1103-00		RES, FXD, FILM: 10K OHM, 5%, 0.2M	57668	TR20JE10K0
A5R2405	313-1104-00		RES, FXD, FILM: 100K OHM, 5%, 0.2M	57668	TR20JE100K
A5R2406	313-1104-00		RES, FXD, FILM: 100K OHM, 5%, 0.2M	57668	TR20JE100K
A5R2407	313-1103-00		RES, FXD, FILM: 10K OHM, 5%, 0.2M	57668	TR20JE10K0
A5R2408	313-1103-00		RES, FXD, FILM: 10K OHM, 5%, 0.2M	57668	TR20JE10K0
A5R2409	313-1103-00		RES, FXD, FILM: 10K OHM, 5%, 0.2M	57668	TR20JE10K0
A5R2410	313-1104-00		RES, FXD, FILM: 100K OHM, 5%, 0.2M	57668	TR20JE100K
A5R2411	313-1103-00		RES, FXD, FILM: 10K OHM, 5%, 0.2M	57668	TR20JE10K0
A5R2412	313-1104-00		RES, FXD, FILM: 100K OHM, 5%, 0.2M	57668	TR20JE100K
A5R2413	313-1103-00		RES, FXD, FILM: 10K OHM, 5%, 0.2M	57668	TR20JE10K0
A5R2414	313-1103-00		RES, FXD, FILM: 10K OHM, 5%, 0.2M	57668	TR20JE10K0
A5R2415	313-1103-00		RES, FXD, FILM: 10K OHM, 5%, 0.2M	57668	TR20JE10K0
A5R2416	313-1103-00		RES, FXD, FILM: 10K OHM, 5%, 0.2M	57668	TR20JE10K0
A5R2417	313-1103-00		RES, FXD, FILM: 10K OHM, 5%, 0.2M	57668	TR20JE10K0
A5R2420	313-1103-00		RES, FXD, FILM: 10K OHM, 5%, 0.2M	57668	TR20JE10K0
A5R2421	322-3300-02		RES, FXD, FILM: 13K OHM, 0.5%, 0.2M, TC=T2	57668	CR820 DYE 13K0
A5R2422	322-3482-02		RES, FXD, FILM: 14.2K OHM, 0.5%, 0.2M, TC=T0	57668	CR8 20 DYE 14K2
A5R2430	322-3289-02		RES, FXD, FILM: 10K OHM, 0.5%, 0.2M, TC=T2	57668	CR8 20 DYE 10K0
A5R2431	313-1101-00		RES, FXD, FILM: 100 OHM, 5%, 0.2M	57668	TR20JE100E

2455A Replaceable Electrical Parts
2445A/2455A Service

Component No.	Tektronix Part No.	Serial/Assembly No. Effective Dscnt	Name & Description	Mfr. Code	Mfr. Part No.
A5R2432	322-3325-00		RES,FXD,FILM:23.7K OHM,1%,0.2M,TC=TO	57668	CRB20 FXE 23K7
A5R2433	322-3289-02		RES,FXD,FILM:10K OHM,0.5%,0.2M,TC=T2	57668	CRB 20 DYE 10K0
A5R2434	322-3289-02		RES,FXD,FILM:10K OHM,0.5%,0.2M,TC=T2	57668	CRB 20 DYE 10K0
A5R2440	313-1104-00		RES,FXD,FILM:100K OHM,5%,0.2M	57668	TR20JE100K
A5R2441	313-1104-00		RES,FXD,FILM:100K OHM,5%,0.2M	57668	TR20JE100K
A5R2442	313-1104-00		RES,FXD,FILM:100K OHM,5%,0.2M	57668	TR20JE100K
A5R2443	313-1103-00		RES,FXD,FILM:10K OHM,5%,0.2M	57668	TR20JE10K0
A5R2444	313-1103-00		RES,FXD,FILM:10K OHM,5%,0.2M	57668	TR20JE10K0
A5R2470	313-1681-00		RES,FXD,FILM:680 OHM,5%,0.2M	57668	TR20JE 680E
A5R2471	313-1681-00		RES,FXD,FILM:680 OHM,5%,0.2M	57668	TR20JE 680E
A5R2501	313-1103-00		RES,FXD,FILM:10K OHM,5%,0.2M	57668	TR20JE10K0
A5R2502	313-1103-00		RES,FXD,FILM:10K OHM,5%,0.2M	57668	TR20JE10K0
A5R2503	313-1103-00		RES,FXD,FILM:10K OHM,5%,0.2M	57668	TR20JE10K0
A5R2504	313-1103-00		RES,FXD,FILM:10K OHM,5%,0.2M	57668	TR20JE10K0
A5R2505	313-1103-00		RES,FXD,FILM:10K OHM,5%,0.2M	57668	TR20JE10K0
A5R2506	322-3235-00		RES,FXD,FILM:2.74K OHM,1%,0.2M,TC=TO	57668	CRB20 FXE 2K74
A5R2510	313-1103-00		RES,FXD,FILM:10K OHM,5%,0.2M	57668	TR20JE10K0
A5R2511	313-1102-00		RES,FXD,FILM:1K OHM,5%,0.2M	57668	TR20JE01K0
A5R2512	313-1102-00		RES,FXD,FILM:1K OHM,5%,0.2M	57668	TR20JE01K0
A5R2513	313-1103-00		RES,FXD,FILM:10K OHM,5%,0.2M	57668	TR20JE10K0
A5R2520	322-3177-02		RES,FXD,FILM:681 OHM,0.5%,0.2M,TC=T2	57668	CRB 20 DYE 681E
A5R2521	322-3177-02		RES,FXD,FILM:681 OHM,0.5%,0.2M,TC=T2	57668	CRB 20 DYE 681E
A5R2522	313-1103-00		RES,FXD,FILM:10K OHM,5%,0.2M	57668	TR20JE10K0
A5R2523	313-1683-00		RES,FXD,FILM:68K OHM,5%,0.2M	57668	TR20JE 68K
A5R2524	313-1683-00		RES,FXD,FILM:68K OHM,5%,0.2M	57668	TR20JE 68K
A5R2530	315-0106-00		RES,FXD,FILM:10M OHM,5%,0.25M	01121	CB1065
A5R2531	313-1101-00		RES,FXD,FILM:100 OHM,5%,0.2M	57668	TR20JE100E
A5R2532	313-1683-00		RES,FXD,FILM:68K OHM,5%,0.2M	57668	TR20JE 68K
A5R2533	322-3235-00		RES,FXD,FILM:2.74K OHM,1%,0.2M,TC=TO	57668	CRB20 FXE 2K74
A5R2534	322-3235-00		RES,FXD,FILM:2.74K OHM,1%,0.2M,TC=TO	57668	CRB20 FXE 2K74
A5R2535	322-3235-00		RES,FXD,FILM:2.74K OHM,1%,0.2M,TC=TO	57668	CRB20 FXE 2K74
A5R2536	313-1103-00		RES,FXD,FILM:10K OHM,5%,0.2M	57668	TR20JE10K0
A5R2537	313-1102-00		RES,FXD,FILM:1K OHM,5%,0.2M	57668	TR20JE01K0
A5R2540	313-1103-00		RES,FXD,FILM:10K OHM,5%,0.2M	57668	TR20JE10K0
A5R2541	313-1102-00		RES,FXD,FILM:1K OHM,5%,0.2M	57668	TR20JE01K0
A5R2542	313-1103-00		RES,FXD,FILM:10K OHM,5%,0.2M	57668	TR20JE10K0
A5R2543	313-1102-00		RES,FXD,FILM:1K OHM,5%,0.2M	57668	TR20JE01K0
A5R2544	313-1681-00		RES,FXD,FILM:680 OHM,5%,0.2M	57668	TR20JE 680E
A5R2545	313-1331-00		RES,FXD,FILM:330 OHM,5%,0.2M	57668	TR20JE 330E
A5R2560	313-1222-00		RES,FXD,FILM:2.2K OHM,5%,0.2M	57668	TR20JE 02K2
A5R2601	313-1681-00		RES,FXD,FILM:680 OHM,5%,0.2M	57668	TR20JE 680E
A5R2602	313-1103-00		RES,FXD,FILM:10K OHM,5%,0.2M	57668	TR20JE10K0
A5R2603	313-1103-00		RES,FXD,FILM:10K OHM,5%,0.2M	57668	TR20JE10K0
A5R2604	322-3193-00		RES,FXD,FILM:1K OHM,1%,0.2M,TC=TO	57668	CRB20 FXE 1K00
A5R2610	313-1103-00		RES,FXD,FILM:10K OHM,5%,0.2M	57668	TR20JE10K0
A5R2611	313-1104-00		RES,FXD,FILM:100K OHM,5%,0.2M	57668	TR20JE100K
A5R2612	313-1512-00		RES,FXD,CMP5N:5.1K OHM,5%,0.2M	57668	TR20JE 5K1
A5R2613	313-1103-00		RES,FXD,FILM:10K OHM,5%,0.2M	57668	TR20JE10K0
A5R2620	313-1103-00		RES,FXD,FILM:10K OHM,5%,0.2M	57668	TR20JE10K0
A5R2621	313-1222-00		RES,FXD,FILM:2.2K OHM,5%,0.2M	57668	TR20JE 02K2
A5R2622	313-1101-00		RES,FXD,FILM:100 OHM,5%,0.2M	57668	TR20JE100E
A5R2623	313-1222-00		RES,FXD,FILM:2.2K OHM,5%,0.2M	57668	TR20JE 02K2
A5R2624	313-1512-00		RES,FXD,CMP5N:5.1K OHM,5%,0.2M	57668	TR20JE 5K1
A5R2630	322-3193-00		RES,FXD,FILM:1K OHM,1%,0.2M,TC=TO	57668	CRB20 FXE 1K00
A5R2631	322-3235-00		RES,FXD,FILM:2.74K OHM,1%,0.2M,TC=TO	57668	CRB20 FXE 2K74
A5R2632	322-3193-00		RES,FXD,FILM:1K OHM,1%,0.2M,TC=TO	57668	CRB20 FXE 1K00
A5R2640	313-1103-00		RES,FXD,FILM:10K OHM,5%,0.2M	57668	TR20JE10K0
A5R2641	313-1103-00		RES,FXD,FILM:10K OHM,5%,0.2M	57668	TR20JE10K0
A5R2642	313-1103-00		RES,FXD,FILM:10K OHM,5%,0.2M	57668	TR20JE10K0

2455A Replaceable Electrical Parts
2445A/2455A Service

Component No.	Tektronix Part No.	Serial/Assembly No. Effective Dscont	Name & Description	Mfr. Code	Mfr. Part No.
A5R2643	313-1103-00		RES,FXD,FILM:10K OHM,5%,0.2M	57668	TR20JE10K0
A5R2644	313-1103-00		RES,FXD,FILM:10K OHM,5%,0.2M	57668	TR20JE10K0
A5R2645	313-1103-00		RES,FXD,FILM:10K OHM,5%,0.2M	57668	TR20JE10K0
A5R2660	313-1103-00		RES,FXD,FILM:10K OHM,5%,0.2M	57668	TR20JE10K0
A5R2661	313-1103-00		RES,FXD,FILM:10K OHM,5%,0.2M	57668	TR20JE10K0
A5R2701	313-1103-00		RES,FXD,FILM:10K OHM,5%,0.2M	57668	TR20JE10K0
A5R2702	313-1103-00		RES,FXD,FILM:10K OHM,5%,0.2M	57668	TR20JE10K0
A5R2703	313-1103-00		RES,FXD,FILM:10K OHM,5%,0.2M	57668	TR20JE10K0
A5R2704	313-1103-00		RES,FXD,FILM:10K OHM,5%,0.2M	57668	TR20JE10K0
A5R2705	313-1103-00		RES,FXD,FILM:10K OHM,5%,0.2M	57668	TR20JE10K0
A5R2706	313-1103-00		RES,FXD,FILM:10K OHM,5%,0.2M	57668	TR20JE10K0
A5R2707	313-1103-00		RES,FXD,FILM:10K OHM,5%,0.2M	57668	TR20JE10K0
A5R2708	313-1103-00		RES,FXD,FILM:10K OHM,5%,0.2M	57668	TR20JE10K0
A5R2709	313-1103-00		RES,FXD,FILM:10K OHM,5%,0.2M	57668	TR20JE10K0
A5R2710	313-1103-00		RES,FXD,FILM:10K OHM,5%,0.2M	57668	TR20JE10K0
A5R2711	313-1103-00		RES,FXD,FILM:10K OHM,5%,0.2M	57668	TR20JE10K0
A5R2712	313-1103-00		RES,FXD,FILM:10K OHM,5%,0.2M	57668	TR20JE10K0
A5R2720	313-1103-00		RES,FXD,FILM:10K OHM,5%,0.2M	57668	TR20JE10K0
A5R2721	313-1203-00		RES,FXD,FILM:20K OHM,5%,0.2M	57668	TR20JE20K
A5R2730	313-1203-00		RES,FXD,FILM:20K OHM,5%,0.2M	57668	TR20JE20K
A5R2731	315-0107-00		RES,FXD,FILM:100M OHM,5%,0.25M	01121	CB1075
A5R2732	315-0107-00		RES,FXD,FILM:100M OHM,5%,0.25M	01121	CB1075
A5R2733	322-3235-00		RES,FXD,FILM:2.74K OHM,1%,0.2M,TC=TO	57668	CRB20 FXE 2K74
A5R2734	313-1102-00		RES,FXD,FILM:1K OHM,5%,0.2M	57668	TR20JED1K0
A5R2735	313-1102-00		RES,FXD,FILM:1K OHM,5%,0.2M	57668	TR20JED1K0
A5R2740	322-3193-00		RES,FXD,FILM:1K OHM,1%,0.2M,TC=TO	57668	CRB20 FXE 1K00
A5R2741	313-1101-00		RES,FXD,FILM:100 OHM,5%,0.2M	57668	TR20JE100E
A5R2742	313-1103-00		RES,FXD,FILM:10K OHM,5%,0.2M	57668	TR20JE10K0
A5R2770	313-1103-00		RES,FXD,FILM:10K OHM,5%,0.2M	57668	TR20JE10K0
A5TP2070	131-0608-00		TERMINAL,PIN:0.365 L X 0.025 BRZ GLD PL	22526	48283-036
A5TP2420	131-0608-00		TERMINAL,PIN:0.365 L X 0.025 BRZ GLD PL	22526	48283-036
A5TP2421	131-0608-00		TERMINAL,PIN:0.365 L X 0.025 BRZ GLD PL	22526	48283-036
A5TP2701	131-0608-00		TERMINAL,PIN:0.365 L X 0.025 BRZ GLD PL	22526	48283-036
A5U2101	156-1589-00		MICROCKT,LINEAR:DAC,12 BIT,HIGH SPEED,MONO	06665	DAC312FR
A5U2140	156-1342-01		MICROCKT,DGTL:NMOS,MPU,8-BIT M/CLK	04713	SC67127P
A5U2160	160-3302-03		MICROCKT,DGTL:65536 X 8 EPROM,PRGM	80009	160-3302-03
A5U2201	156-0865-02		MICROCKT,DGTL:OCTAL D FF M/CLEAR	01295	SN74LS273NP3
A5U2210	156-0391-02		MICROCKT,DGTL:HEX LATCH M/CLEAR	01295	SN74LS174NP3
A5U2220	156-0956-02		MICROCKT,DGTL:OCTAL BFR M/3 STATE OUT	01295	SN74LS244NP3
A5U2240	156-2396-00		MICROCKT,DGTL:RESET GENERATOR,5V SUPPLY	01295	TL7705 ACP
A5U2250	160-3635-01		MICROCKT,DGTL:OCTAL 16-IN AOI GATE ARRAY	80009	160-3635-01
A5U2260	160-3303-03		MICROCKT,DGTL:65536 X 8 EPROM,PRGM	80009	160-3303-03
A5U2301	156-0865-02		MICROCKT,DGTL:OCTAL D FF M/CLEAR	01295	SN74LS273NP3
A5U2310	156-0391-02		MICROCKT,DGTL:HEX LATCH M/CLEAR	01295	SN74LS174NP3
A5U2350	156-0956-02		MICROCKT,DGTL:OCTAL BFR M/3 STATE OUT	01295	SN74LS244NP3
A5U2401	156-0513-03		MICROCKT,LINEAR:CMOS,8 CHAN ANALOG MUX	04713	MC140518CL
A5U2410	156-1486-00		MICROCKT,DGTL:8 CHANNEL DATA SEL,SCREENED	02735	CD45128FX
A5U2420	156-1200-01		MICROCKT,LINEAR:OPERATIONAL AMPL,QUAD BIFET	80009	156-1200-01
A5U2430	156-1200-01		MICROCKT,LINEAR:OPERATIONAL AMPL,QUAD BIFET	80009	156-1200-01
A5U2440	156-0388-03		MICROCKT,DGTL:DUAL D FLIP-FLOP	01295	SN74LS74NP3
A5U2450	156-1065-01		MICROCKT,DGTL:OCTAL D TYPE TRANS LATCHES	04713	SN74LS373 NJ/J0
A5U2460	156-2473-00		MICROCKT,DGTL:8192 X 8 SRAM,LOW STANDBY PMR	TK0961	uPD4464C-20
A5U2501	156-0513-03		MICROCKT,LINEAR:CMOS,8 CHAN ANALOG MUX	04713	MC140518CL
A5U2510	156-1126-01		MICROCKT,LINEAR:VOLTAGE COMPARATOR,SELECTED	01295	LM311J64
A5U2520	156-1191-01		MICROCKT,LINEAR:DUAL BI-FET OP-AMP,8 OIP	80009	156-1191-01
A5U2521	156-0513-03		MICROCKT,LINEAR:CMOS,8 CHAN ANALOG MUX	04713	MC140518CL
A5U2530	156-0513-03		MICROCKT,LINEAR:CMOS,8 CHAN ANALOG MUX	04713	MC140518CL
A5U2540	156-1722-00		MICROCKT,DGTL:HEX INVERTER	04713	MC74F04ND
A5U2550	156-0469-02		MICROCKT,DGTL:3/8 LINE DCOR	01295	SN74LS138NP3

Component No.	Tektronix Part No.	Serial/Assembly No. Effective Dscont	Name & Description	Mfr. Code	Mfr. Part No.
A5U2601	156-0513-03		MICROCKT, LINEAR: CMOS, 8 CHAN ANALOG MIX	04713	MC140518CL
A5U2620	156-1200-01		MICROCKT, LINEAR: OPERATIONAL AMPL, QUAD BIFET	80009	156-1200-01
A5U2630	156-1200-01		MICROCKT, LINEAR: OPERATIONAL AMPL, QUAD BIFET	80009	156-1200-01
A5U2640	156-0895-01		MICROCKT, DGTL: 14 BIT BINARY COUNTER, BURN-IN	02735	CD40208FX
A5U2650	156-0804-02		MICROCKT, DGTL: QUADRUPLE S-R LATCH	01295	SN74LS279NP3/JP4
A5U2660	156-1026-02		MICROCKT, DGTL: 4/1 LINE DECODER, SCRN	01295	SN74LS154N P3
A5VR2420	152-0278-00		SEMICON DVC, DI: ZEN, SI, 3V, 5%, 0.4M, D0-7	04713	5ZG35009K20
A5M511	174-0002-00		CA ASSY, SP, ELEC: 26, 28 ANG, 2.0 L	80009	174-0002-00
A5M512	174-0001-00		CA ASSY, SP, ELEC: 34, 28 ANG, 2.0 L	80009	174-0001-00
A5M2070	131-0566-00		BUS, COND: DUMMY RES, 0.094 00 X 0.225L	24546	0MA 07
A5M2240	131-1817-00		BUS, CONDUCTOR: 22ANG, BARE, 2.25 L	80009	131-1817-00
A5M2810	131-1817-00		BUS, CONDUCTOR: 22ANG, BARE, 2.25 L	80009	131-1817-00
A5M2701	131-0566-00		BUS, COND: DUMMY RES, 0.094 00 X 0.225L	24546	0MA 07
A5Y2540	158-0248-00		XTAL UNIT, QTZ: 10MHZ, 0.01%, SERIES	14301	HC-18/U
A6	614-0448-00		FRONT PNL ASSY: STANDARD	80009	614-0448-00
A6P3001	131-3478-01		CONN, RCPT, ELEC: VERT, 2 X 10, 0.1 SPACING	80009	131-3478-01
A6R3007	311-2318-00		RES, VAR, NONWH: 5K OHM, 30%, 0.5M	32997	ADVISE
A6R3008	311-2316-00		RES, VAR, NONWH: 2K OHM, 20%, 0.5M	32997	ADVISE
A6R3009	311-2317-00		RES, VAR, NONWH: 5K OHM, 30%, 0.25M	32997	ADVISE
A6R3010	311-2318-00		RES, VAR, NONWH: 5K OHM, 30%, 0.5M	32997	ADVISE
A6R3011	311-2316-00		RES, VAR, NONWH: 2K OHM, 20%, 0.5M	32997	ADVISE
A6R3012	311-2317-00		RES, VAR, NONWH: 5K OHM, 30%, 0.25M	32997	ADVISE
A6R3013	311-2316-00		RES, VAR, NONWH: 2K OHM, 20%, 0.5M	32997	ADVISE
A6R3014	311-2318-00		RES, VAR, NONWH: 5K OHM, 30%, 0.5M	32997	ADVISE
A6R3015	311-2316-00		RES, VAR, NONWH: 2K OHM, 20%, 0.5M	32997	ADVISE
A6R3016	311-2316-00		RES, VAR, NONWH: 2K OHM, 20%, 0.5M	32997	ADVISE
A6R3017	311-2316-00		RES, VAR, NONWH: 2K OHM, 20%, 0.5M	32997	ADVISE
A6R3018	311-2318-00		RES, VAR, NONWH: 5K OHM, 30%, 0.5M	32997	ADVISE
A6R3019	311-2316-00		RES, VAR, NONWH: 2K OHM, 20%, 0.5M	32997	ADVISE
A6A1	-----		CIRCUIT BD ASSY: SYNCHRONIZER		
A6A1C3001	281-0909-00		CAP, FXD, CER DI: 0.022UF, 20%, 50V	54583	MA12X7R1H223M-T
A6A1C3002	281-0909-00		CAP, FXD, CER DI: 0.022UF, 20%, 50V	54583	MA12X7R1H223M-T
A6A1C3019	281-0909-00		CAP, FXD, CER DI: 0.022UF, 20%, 50V	54583	MA12X7R1H223M-T
A6A1CR3001	152-0141-02		SEMICON DVC, DI: SM, SI, 30V, 150MA, 30V, D0-35	03508	DA2527 (1N4152)
A6A1CR3002	152-0141-02		SEMICON DVC, DI: SM, SI, 30V, 150MA, 30V, D0-35	03508	DA2527 (1N4152)
A6A1CR3003	152-0141-02		SEMICON DVC, DI: SM, SI, 30V, 150MA, 30V, D0-35	03508	DA2527 (1N4152)
A6A1CR3004	152-0141-02		SEMICON DVC, DI: SM, SI, 30V, 150MA, 30V, D0-35	03508	DA2527 (1N4152)
A6A1CR3005	152-0141-02		SEMICON DVC, DI: SM, SI, 30V, 150MA, 30V, D0-35	03508	DA2527 (1N4152)
A6A1CR3006	152-0141-02		SEMICON DVC, DI: SM, SI, 30V, 150MA, 30V, D0-35	03508	DA2527 (1N4152)
A6A1CR3007	152-0141-02		SEMICON DVC, DI: SM, SI, 30V, 150MA, 30V, D0-35	03508	DA2527 (1N4152)
A6A1CR3008	152-0141-02		SEMICON DVC, DI: SM, SI, 30V, 150MA, 30V, D0-35	03508	DA2527 (1N4152)
A6A1CR3009	152-0141-02		SEMICON DVC, DI: SM, SI, 30V, 150MA, 30V, D0-35	03508	DA2527 (1N4152)
A6A1CR3010	152-0141-02		SEMICON DVC, DI: SM, SI, 30V, 150MA, 30V, D0-35	03508	DA2527 (1N4152)
A6A1CR3011	152-0141-02		SEMICON DVC, DI: SM, SI, 30V, 150MA, 30V, D0-35	03508	DA2527 (1N4152)
A6A1CR3012	152-0141-02		SEMICON DVC, DI: SM, SI, 30V, 150MA, 30V, D0-35	03508	DA2527 (1N4152)
A6A1CR3013	152-0141-02		SEMICON DVC, DI: SM, SI, 30V, 150MA, 30V, D0-35	03508	DA2527 (1N4152)
A6A1CR3014	152-0141-02		SEMICON DVC, DI: SM, SI, 30V, 150MA, 30V, D0-35	03508	DA2527 (1N4152)
A6A1CR3015	152-0141-02		SEMICON DVC, DI: SM, SI, 30V, 150MA, 30V, D0-35	03508	DA2527 (1N4152)
A6A1CR3016	152-0141-02		SEMICON DVC, DI: SM, SI, 30V, 150MA, 30V, D0-35	03508	DA2527 (1N4152)
A6A1CR3017	152-0141-02		SEMICON DVC, DI: SM, SI, 30V, 150MA, 30V, D0-35	03508	DA2527 (1N4152)
A6A1CR3018	152-0141-02		SEMICON DVC, DI: SM, SI, 30V, 150MA, 30V, D0-35	03508	DA2527 (1N4152)
A6A1CR3019	152-0141-02		SEMICON DVC, DI: SM, SI, 30V, 150MA, 30V, D0-35	03508	DA2527 (1N4152)
A6A1CR3020	152-0141-02		SEMICON DVC, DI: SM, SI, 30V, 150MA, 30V, D0-35	03508	DA2527 (1N4152)
A6A1CR3021	152-0141-02		SEMICON DVC, DI: SM, SI, 30V, 150MA, 30V, D0-35	03508	DA2527 (1N4152)

2455A Replaceable Electrical Parts
 2445A/2455A Service

Component No.	Tektronix Part No.	Serial/Assembly No. Effective Decont	Name & Description	Mfr. Code	Mfr. Part No.
A6A1CR3022	152-0141-02		SEMICOND DVC,DI:SM,SI,30V,150MA,30V,DO-35	03508	DA2527 (1M4152)
A6A1CR3023	152-0141-02		SEMICOND DVC,DI:SM,SI,30V,150MA,30V,DO-35	03508	DA2527 (1M4152)
A6A1CR3024	152-0141-02		SEMICOND DVC,DI:SM,SI,30V,150MA,30V,DO-35	03508	DA2527 (1M4152)
A6A1CR3025	152-0141-02		SEMICOND DVC,DI:SM,SI,30V,150MA,30V,DO-35	03508	DA2527 (1M4152)
A6A1CR3026	152-0141-02		SEMICOND DVC,DI:SM,SI,30V,150MA,30V,DO-35	03508	DA2527 (1M4152)
A6A1CR3027	152-0141-02		SEMICOND DVC,DI:SM,SI,30V,150MA,30V,DO-35	03508	DA2527 (1M4152)
A6A1CR3028	152-0141-02		SEMICOND DVC,DI:SM,SI,30V,150MA,30V,DO-35	03508	DA2527 (1M4152)
A6A1CR3029	152-0141-02		SEMICOND DVC,DI:SM,SI,30V,150MA,30V,DO-35	03508	DA2527 (1M4152)
A6A1CR3030	152-0141-02		SEMICOND DVC,DI:SM,SI,30V,150MA,30V,DO-35	03508	DA2527 (1M4152)
A6A1CR3031	152-0141-02		SEMICOND DVC,DI:SM,SI,30V,150MA,30V,DO-35	03508	DA2527 (1M4152)
A6A1CR3032	152-0141-02		SEMICOND DVC,DI:SM,SI,30V,150MA,30V,DO-35	03508	DA2527 (1M4152)
A6A1CR3033	152-0141-02		SEMICOND DVC,DI:SM,SI,30V,150MA,30V,DO-35	03508	DA2527 (1M4152)
A6A1CR3034	152-0141-02		SEMICOND DVC,DI:SM,SI,30V,150MA,30V,DO-35	03508	DA2527 (1M4152)
A6A1CR3035	152-0141-02		SEMICOND DVC,DI:SM,SI,30V,150MA,30V,DO-35	03508	DA2527 (1M4152)
A6A1CR3036	152-0141-02		SEMICOND DVC,DI:SM,SI,30V,150MA,30V,DO-35	03508	DA2527 (1M4152)
A6A1CR3037	152-0141-02		SEMICOND DVC,DI:SM,SI,30V,150MA,30V,DO-35	03508	DA2527 (1M4152)
A6A1CR3038	152-0141-02		SEMICOND DVC,DI:SM,SI,30V,150MA,30V,DO-35	03508	DA2527 (1M4152)
A6A1CR3039	152-0141-02		SEMICOND DVC,DI:SM,SI,30V,150MA,30V,DO-35	03508	DA2527 (1M4152)
A6A1CR3040	152-0141-02		SEMICOND DVC,DI:SM,SI,30V,150MA,30V,DO-35	03508	DA2527 (1M4152)
A6A1CR3041	152-0141-02		SEMICOND DVC,DI:SM,SI,30V,150MA,30V,DO-35	03508	DA2527 (1M4152)
A6A1CR3042	152-0141-02		SEMICOND DVC,DI:SM,SI,30V,150MA,30V,DO-35	03508	DA2527 (1M4152)
A6A1CR3043	152-0141-02		SEMICOND DVC,DI:SM,SI,30V,150MA,30V,DO-35	03508	DA2527 (1M4152)
A6A1DS3001	150-1161-00		LT EMITTING DIO:YELLOW	50434	QLMP 1487
A6A1DS3002	150-1160-00		LT EMITTING DIO:GREEN	50434	QLMP 1587
A6A1DS3003	150-1160-00		LT EMITTING DIO:GREEN	50434	QLMP 1587
A6A1DS3004	150-1160-00		LT EMITTING DIO:GREEN	50434	QLMP 1587
A6A1DS3005	150-1160-00		LT EMITTING DIO:GREEN	50434	QLMP 1587
A6A1DS3006	150-1161-00		LT EMITTING DIO:YELLOW	50434	QLMP 1487
A6A1DS3007	150-1160-00		LT EMITTING DIO:GREEN	50434	QLMP 1587
A6A1DS3008	150-1160-00		LT EMITTING DIO:GREEN	50434	QLMP 1587
A6A1DS3009	150-1160-00		LT EMITTING DIO:GREEN	50434	QLMP 1587
A6A1DS3010	150-1160-00		LT EMITTING DIO:GREEN	50434	QLMP 1587
A6A1DS3011	150-1160-00		LT EMITTING DIO:GREEN	50434	QLMP 1587
A6A1DS3012	150-1161-00		LT EMITTING DIO:YELLOW	50434	QLMP 1487
A6A1DS3013	150-1160-00		LT EMITTING DIO:GREEN	50434	QLMP 1587
A6A1DS3014	150-1160-00		LT EMITTING DIO:GREEN	50434	QLMP 1587
A6A1DS3015	150-1160-00		LT EMITTING DIO:GREEN	50434	QLMP 1587
A6A1DS3016	150-1160-00		LT EMITTING DIO:GREEN	50434	QLMP 1587
A6A1DS3017	150-1161-00		LT EMITTING DIO:YELLOW	50434	QLMP 1487
A6A1DS3018	150-1160-00		LT EMITTING DIO:GREEN	50434	QLMP 1587
A6A1DS3019	150-1161-00		LT EMITTING DIO:YELLOW	50434	QLMP 1487
A6A1DS3020	150-1160-00		LT EMITTING DIO:GREEN	50434	QLMP 1587
A6A1DS3021	150-1161-00		LT EMITTING DIO:YELLOW	50434	QLMP 1487
A6A1DS3022	150-1161-00		LT EMITTING DIO:YELLOW	50434	QLMP 1487
A6A1DS3023	150-1160-00		LT EMITTING DIO:GREEN	50434	QLMP 1587
A6A1DS3024	150-1160-00		LT EMITTING DIO:GREEN	50434	QLMP 1587
A6A1DS3025	150-1160-00		LT EMITTING DIO:GREEN	50434	QLMP 1587
A6A1DS3026	150-1160-00		LT EMITTING DIO:GREEN	50434	QLMP 1587
A6A1DS3027	150-1161-00		LT EMITTING DIO:YELLOW	50434	QLMP 1487
A6A1DS3028	150-1161-00		LT EMITTING DIO:YELLOW	50434	QLMP 1487
A6A1DS3029	150-1160-00		LT EMITTING DIO:GREEN	50434	QLMP 1587
A6A1DS3030	150-1160-00		LT EMITTING DIO:GREEN	50434	QLMP 1587
A6A1DS3031	150-1160-00		LT EMITTING DIO:GREEN	50434	QLMP 1587
A6A1DS3032	150-1160-00		LT EMITTING DIO:GREEN	50434	QLMP 1587
A6A1DS3033	150-1161-00		LT EMITTING DIO:YELLOW	50434	QLMP 1487
A6A1DS3034	150-1160-00		LT EMITTING DIO:GREEN	50434	QLMP 1587
A6A1DS3035	150-1160-00		LT EMITTING DIO:GREEN	50434	QLMP 1587
A6A1DS3036	150-1161-00		LT EMITTING DIO:YELLOW	50434	QLMP 1487
A6A1DS3037	150-1160-00		LT EMITTING DIO:GREEN	50434	QLMP 1587

2455A Replaceable Electrical Parts
2445A/2455A Service

Component No.	Tektronix Part No.	Serial/Assembly No. Effective Dscont	Name & Description	Mfr. Code	Mfr. Part No.
A6A1D53038	150-1160-00		LT EMITTING DIO:GREEN	50434	QLMP 1587
A6A1D53039	150-1160-00		LT EMITTING DIO:GREEN	50434	QLMP 1587
A6A1D53040	150-1160-00		LT EMITTING DIO:GREEN	50434	QLMP 1587
A6A1D53041	150-1161-00		LT EMITTING DIO:YELLOW	50434	QLMP 1487
A6A1D53042	150-1160-00		LT EMITTING DIO:GREEN	50434	QLMP 1587
A6A1D53043	150-1161-00		LT EMITTING DIO:YELLOW	50434	QLMP 1487
A6A1D53044	150-1161-00		LT EMITTING DIO:YELLOW	50434	QLMP 1487
A6A1D53045	150-1161-00		LT EMITTING DIO:YELLOW	50434	QLMP 1487
A6A1D53046	150-1160-00		LT EMITTING DIO:GREEN	50434	QLMP 1587
A6A1D53047	150-1160-00		LT EMITTING DIO:GREEN	50434	QLMP 1587
A6A1D53048	150-1160-00		LT EMITTING DIO:GREEN	50434	QLMP 1587
A6A1D53049	150-1160-00		LT EMITTING DIO:GREEN	50434	QLMP 1587
A6A1R3001	307-0486-00		RES NTWK,FXD,FI:100 OHM,20%,1.125M	11236	750-101-R100 OHM
A6A1R3002	307-0695-00		RES NTWK,FXD,FI:9,150 OHM,ZX,0.2M EA	11236	750-101-R150 OHM
A6A1R3003	307-0486-00		RES NTWK,FXD,FI:100 OHM,20%,1.125M	11236	750-101-R100 OHM
A6A1R3004	313-1151-00		RES,FXD,FILM:150 OHM,5%,0.2M	57668	TR20JE150E
A6A1R3005	313-1151-00		RES,FXD,FILM:150 OHM,5%,0.2M	57668	TR20JE150E
A6A1R3006	313-1101-00		RES,FXD,FILM:100 OHM,5%,0.2M	57668	TR20JE100E
A6A1S3001	260-2280-00		SM,PUSH BUTTON:MINI MOM,SPST,NORM OPEN	80009	260-2280-00
A6A1S3002	260-2280-00		SM,PUSH BUTTON:MINI MOM,SPST,NORM OPEN	80009	260-2280-00
A6A1S3003	260-2280-00		SM,PUSH BUTTON:MINI MOM,SPST,NORM OPEN	80009	260-2280-00
A6A1S3004	260-2283-00		SWITCH,ROTARY:VOLTS/DIV	80009	260-2283-00
A6A1S3005	260-2280-00		SM,PUSH BUTTON:MINI MOM,SPST,NORM OPEN	80009	260-2280-00
A6A1S3006	260-2280-00		SM,PUSH BUTTON:MINI MOM,SPST,NORM OPEN	80009	260-2280-00
A6A1S3007	260-2280-00		SM,PUSH BUTTON:MINI MOM,SPST,NORM OPEN	80009	260-2280-00
A6A1S3008	260-2280-00		SM,PUSH BUTTON:MINI MOM,SPST,NORM OPEN	80009	260-2280-00
A6A1S3009	260-2280-00		SM,PUSH BUTTON:MINI MOM,SPST,NORM OPEN	80009	260-2280-00
A6A1S3010	260-2280-00		SM,PUSH BUTTON:MINI MOM,SPST,NORM OPEN	80009	260-2280-00
A6A1S3011	260-2280-00		SM,PUSH BUTTON:MINI MOM,SPST,NORM OPEN	80009	260-2280-00
A6A1S3012	260-2280-00		SM,PUSH BUTTON:MINI MOM,SPST,NORM OPEN	80009	260-2280-00
A6A1S3013	260-2283-00		SWITCH,ROTARY:VOLTS/DIV	80009	260-2283-00
A6A1S3014	260-2280-00		SM,PUSH BUTTON:MINI MOM,SPST,NORM OPEN	80009	260-2280-00
A6A1S3015	260-2280-00		SM,PUSH BUTTON:MINI MOM,SPST,NORM OPEN	80009	260-2280-00
A6A1S3016	260-2280-00		SM,PUSH BUTTON:MINI MOM,SPST,NORM OPEN	80009	260-2280-00
A6A1S3017	260-2280-00		SM,PUSH BUTTON:MINI MOM,SPST,NORM OPEN	80009	260-2280-00
A6A1S3018	260-2280-00		SM,PUSH BUTTON:MINI MOM,SPST,NORM OPEN	80009	260-2280-00
A6A1S3019	260-2283-00		SWITCH,ROTARY:VOLTS/DIV	80009	260-2283-00
A6A1S3020	260-2280-00		SM,PUSH BUTTON:MINI MOM,SPST,NORM OPEN	80009	260-2280-00
A6A1S3021	260-2164-01		SWITCH,SLIDE:SPDT,4A,20VAC	09353	1101 AV2 8E2
A6A1S3022	260-2280-00		SM,PUSH BUTTON:MINI MOM,SPST,NORM OPEN	80009	260-2280-00
A6A1S3023	260-2280-00		SM,PUSH BUTTON:MINI MOM,SPST,NORM OPEN	80009	260-2280-00
A6A1S3024	260-2280-00		SM,PUSH BUTTON:MINI MOM,SPST,NORM OPEN	80009	260-2280-00
A6A1S3025	260-2280-00		SM,PUSH BUTTON:MINI MOM,SPST,NORM OPEN	80009	260-2280-00
A6A1S3026	260-2280-00		SM,PUSH BUTTON:MINI MOM,SPST,NORM OPEN	80009	260-2280-00
A6A1S3027	260-2280-00		SM,PUSH BUTTON:MINI MOM,SPST,NORM OPEN	80009	260-2280-00
A6A1S3028	260-2280-00		SM,PUSH BUTTON:MINI MOM,SPST,NORM OPEN	80009	260-2280-00
A6A1S3029	260-2280-00		SM,PUSH BUTTON:MINI MOM,SPST,NORM OPEN	80009	260-2280-00
A6A1S3030	260-2280-00		SM,PUSH BUTTON:MINI MOM,SPST,NORM OPEN	80009	260-2280-00
A6A1S3031	260-2280-00		SM,PUSH BUTTON:MINI MOM,SPST,NORM OPEN	80009	260-2280-00
A6A1S3032	260-2280-00		SM,PUSH BUTTON:MINI MOM,SPST,NORM OPEN	80009	260-2280-00
A6A1S3033	260-2280-00		SM,PUSH BUTTON:MINI MOM,SPST,NORM OPEN	80009	260-2280-00
A6A1S3034	260-2280-00		SM,PUSH BUTTON:MINI MOM,SPST,NORM OPEN	80009	260-2280-00
A6A1U3001	156-2120-00		MICROCKT,DGTL:SERIAL-IN PARALLEL-OUT SHIFT	07263	74F164PCQR/DCQR
A6A1U3002	156-2120-00		MICROCKT,DGTL:SERIAL-IN PARALLEL-OUT SHIFT	07263	74F164PCQR/DCQR
A6A1U3003	156-2120-00		MICROCKT,DGTL:SERIAL-IN PARALLEL-OUT SHIFT	07263	74F164PCQR/DCQR
A6A1U3004	156-2120-00		MICROCKT,DGTL:SERIAL-IN PARALLEL-OUT SHIFT	07263	74F164PCQR/DCQR
A6A1U3005	156-2120-00		MICROCKT,DGTL:SERIAL-IN PARALLEL-OUT SHIFT	07263	74F164PCQR/DCQR
A6A1U3006	156-2120-00		MICROCKT,DGTL:SERIAL-IN PARALLEL-OUT SHIFT	07263	74F164PCQR/DCQR

2455A Replaceable Electrical Parts
2445A/2455A Service

Component No.	Tektronix Part No.	Serial/Assembly No. Effective Dscont	Name & Description	Mfr. Code	Mfr. Part No.
A8	670-7280-00		CIRCUIT BD ASSY:SCALE ILLUM	80009	670-7280-00
A805100	150-0057-01		LAMP, INCAND:5V,0.115A,MIRE LD,AGED & SEL	71744	7153 AS 15
A805101	150-0057-01		LAMP, INCAND:5V,0.115A,MIRE LD,AGED & SEL	71744	7153 AS 15
A805102	150-0057-01		LAMP, INCAND:5V,0.115A,MIRE LD,AGED & SEL	71744	7153 AS 15
A9	670-7277-08		CIRCUIT BD ASSY:HIGH VOLTAGE	80009	670-7277-08
A9C91	283-0084-00		CAP,FXD,CER 01:270PF,5%,1000V	59660	838533X5F02715
A9C1812	285-1236-00		CAP,FXD,PLASTIC:0.022UF,20%,400V	14752	23001E223M
A9C1813	285-1236-00		CAP,FXD,PLASTIC:0.022UF,20%,400V	14752	23001E223M
A9C1870	281-0773-00		CAP,FXD,CER 01:0.01UF,10%,100V	04222	MA201C103KAA
A9C1886	285-1236-00		CAP,FXD,PLASTIC:0.022UF,20%,400V	14752	23001E223M
A9C1888	285-1236-00		CAP,FXD,PLASTIC:0.022UF,20%,400V	14752	23001E223M
A9C1889	285-1236-00		CAP,FXD,PLASTIC:0.022UF,20%,400V	14752	23001E223M
A9C1890	281-0775-00		CAP,FXD,CER 01:0.1UF,20%,50V	04222	MA205E104MAA
A9C1891	281-0775-00		CAP,FXD,CER 01:0.1UF,20%,50V	04222	MA205E104MAA
A9C1912	281-0798-00		CAP,FXD,CER 01:51PF,1%,100V	04222	MA101A510GAA
A9C1915	281-0783-00		CAP,FXD,CER 01:0.1 UF 20%,100V	04222	MA401C104MAA
A9C1932	281-0775-00		CAP,FXD,CER 01:0.1UF,20%,50V	04222	MA205E104MAA
A9C1950	281-0766-00		CAP,FXD,CER 01:100PF,20%,200V	04222	MA106A101MAA
A9C1951	290-0269-01		CAP,FXD,ELCTLT:0.22UF,5%,35V,1KHZ,TANTULUM	56289	1730224X5035U
A9C1971	285-1236-00		CAP,FXD,PLASTIC:0.022UF,20%,400V	14752	23001E223M
A9C1972	290-0747-00		CAP,FXD,ELCTLT:100UF,+50-10%,25V	54473	ECE-825V100L
A9C1973	281-0826-00		CAP,FXD,CER 01:2200PF,5%,100V	20932	401EM100A0222K
A9C1980	281-0771-00		CAP,FXD,CER 01:2200PF,220%,200V	04222	MA106E222MAA
A9C1990	285-1096-00		CAP,FXD,PLASTIC:1UF,10%,50V	14752	23081A105K
A9C1991	281-0826-00		CAP,FXD,CER 01:2200PF,5%,100V	20932	401EM100A0222K
A9CR1894	152-0400-00		SEMICOND DVC,DI:RECT,SI,400V,1A	04713	SR1977K
A9CR1895	152-0400-00		SEMICOND DVC,DI:RECT,SI,400V,1A	04713	SR1977K
A9CR1915	152-0061-00		SEMICOND DVC,DI:SM,SI,175V,0.1A,DO-35	07263	FDH2161
A9CR1930	152-0061-00		SEMICOND DVC,DI:SM,SI,175V,0.1A,DO-35	07263	FDH2161
A9CR1950	152-0061-00		SEMICOND DVC,DI:SM,SI,175V,0.1A,DO-35	07263	FDH2161
A9CR1953	152-0061-00		SEMICOND DVC,DI:SM,SI,175V,0.1A,DO-35	07263	FDH2161
A9CR1990	152-0141-02		SEMICOND DVC,DI:SM,SI,30V,150MA,30V,DO-35	03508	DA2527 (1N4152)
A9DS90	150-0030-00		LAMP,GLOW:60-90V MAX,0.7MA,A2B-T,MIRE LEADS	58224	A2B-T
A9DS91	150-0030-00		LAMP,GLOW:60-90V MAX,0.7MA,A2B-T,MIRE LEADS	58224	A2B-T
A9J901	131-0589-00		TERMINAL,PIN:0.46 L X 0.025 SQ PH BR/ (QUANTITY OF 9)	22526	48283-029
A9J902	131-0589-00		TERMINAL,PIN:0.46 L X 0.025 SQ PH BRZ (QUANTITY OF 2)	22526	48283-029
A9J903	131-0589-00		TERMINAL,PIN:0.46 L X 0.025 SQ PH BRZ (QUANTITY OF 2)	22526	48283-029
A9J904	131-0589-00		TERMINAL,PIN:0.46 L X 0.025 SQ PH BRZ	22526	48283-029
A9L1921	108-0262-00		COIL,RF:FIXED,510MH	80009	108-0262-00
A9L1974	108-0318-00		COIL,RF:FIXED,100UH	32159	81000M
A9P191	131-3461-00		HEADER,MICROCKT:14 PIN,0.5 L,GOLD PL	80009	131-3461-00
A9P900	-----		(SUBPART OF A9M900)		
A9Q1851	151-0443-00		TRANSISTOR:PMP,SI,TO-92	04713	SPS7950
A9Q1852	151-0443-00		TRANSISTOR:PMP,SI,TO-92	04713	SPS7950
A9Q1890	151-0443-00		TRANSISTOR:PMP,SI,TO-92	04713	SPS7950
A9Q1891	151-0745-00		TRANSISTOR:PMP,SI,TO-220	61271	2SA10776
A9Q1980	151-0444-00		TRANSISTOR:PNP,SI,TO-92	04713	SPS797
A9R1812	315-0100-02		RES,FXD,CMPSN:10 OHM,5%,0.25M	01121	CB1005
A9R1813	315-0100-02		RES,FXD,CMPSN:10 OHM,5%,0.25M	01121	CB1005
A9R1833	313-1103-00		RES,FXD,FILM:10K OHM,5%,0.2M	57668	TR20JE10K0
A9R1834	313-1103-00		RES,FXD,FILM:10K OHM,5%,0.2M	57668	TR20JE10K0
A9R1842	311-2234-00		RES,VAR,NONHM:TRMR,5K OHM,20%,0.5M	TK1450	GFD0UT 5K

2455A Replaceable Electrical Parts
2445A/2455A Service

Component No.	Tektronix Part No.	Serial/Assembly No. Effective Dscont	Name & Description	Mfr. Code	Mfr. Part No.
A9R1848	311-2234-00		RES,VAR,NONMM:TRMR,5K OHM,20%,0.5M	TK1450	GF06UT 5K
A9R1853	321-0447-00		RES,FXD,FILM:442K OHM,1%,0.125M,TC=TO	24546	NA5504423F
A9R1854	321-0435-00		RES,FXD,FILM:332K OHM,1%,0.125M,TC=TO	07716	CEAD33202F
A9R1855	321-0407-00		RES,FXD,FILM:169K OHM,1%,0.125M,TC=TO	07716	CEAD16902F
A9R1856	321-0367-00		RES,FXD,FILM:64.9K OHM,1%,0.125M,TC=TO	07716	CEAD64901F
A9R1857	321-0364-00		RES,FXD,FILM:60.4K OHM,1%,0.125M,TC=TO	19701	5043ED60K40F
A9R1858	313-1105-00		RES,FXD,FILM:1M OHM,5%,0.2M	57668	TR20JE1M
A9R1864	311-2236-00		RES,VAR,NONMM:TRMR,20K OHM,20%,0.5M LINEAR	TK1450	GF06UT 20K
A9R1870	311-2239-00		RES,VAR,NONMM:TRMR,100K OHM,20%,0.5M LINEAR	TK1450	GF06UT 100K
A9R1871	315-0154-00		RES,FXD,FILM:150K OHM,5%,0.25M	57668	NTR25J-E150K
A9R1872	315-0184-00		RES,FXD,FILM:180K OHM,5%,0.25M	19701	5043CX180K0J
A9R1873	313-1103-00		RES,FXD,FILM:10K OHM,5%,0.2M	57668	TR20JE10K0
A9R1878	311-2239-00		RES,VAR,NONMM:TRMR,100K OHM,20%,0.5M LINEAR	TK1450	GF06UT 100K
A9R1880	315-0434-00		RES,FXD,FILM:430K OHM,5%,0.25M	57668	NTR25J-E430K
A9R1881	321-0385-00		RES,FXD,FILM:100K OHM,1%,0.125M,TC=TO	19701	5033ED100K0F
A9R1890	313-1473-00		RES,FXD,FILM:47K OHM,5%,0.2M	57668	TR20JE 47K
A9R1891	321-0481-04		RES,FXD,FILM:1M OHM,0.1%,0.125M,TC=T2	91637	CMF55116D10003B
A9R1892	321-0639-00		RES,FXD,FILM:9.6K OHM,1%,0.125M,TC=TO	19701	5043ED9K600F
A9R1892	321-0693-00		RES,FXD,FILM:68.1K OHM,0.5%,0.125M,TC=TO	19701	5033RD6812DB2980
A9R1893	321-0481-04		RES,FXD,FILM:1M OHM,0.1%,0.125M,TC=T2	91637	CMF55116D10003B
A9R1895	313-1302-00		RES,FXD,FILM:3K OHM,5%,0.2M	57668	TR20JE 03K0
A9R1896	315-0100-02		RES,FXD,CMPSM:10 OHM,5%,0.25M	01121	CB1005
A9R1897	313-1102-00		RES,FXD,FILM:1K OHM,5%,0.2M	57668	TR20JE01K0
A9R1898	313-1102-00		RES,FXD,FILM:1K OHM,5%,0.2M	57668	TR20JE01K0
A9R1901	315-0101-03		RES,FXD,CMPSM:100 OHM,5%,0.25M	01121	CB1015
A9R1910	321-0271-00		RES,FXD,FILM:6.49K OHM,1%,0.125M,TC=TO	07716	CEAD64900F
A9R1911	321-0245-00		RES,FXD,FILM:3.48K OHM,1%,0.125M,TC=TO	19701	5033ED3K48F
A9R1913	315-0101-03		RES,FXD,CMPSM:100 OHM,5%,0.25M	01121	CB1015
A9R1920	315-0152-00		RES,FXD,FILM:1.5K OHM,5%,0.25M	57668	NTR25J-E1K15
A9R1922	315-0331-03		RES,FXD,CMPSM:330 OHM 5%,0.25M	01121	CB3315
A9R1941	313-1201-00		RES,FXD,FILM:200 OHM,5%,0.2M	57668	TR20JE200E
A9R1944	321-0306-00		RES,FXD,FILM:15.0K OHM,1%,0.125M,TC=TO	19701	5033ED15J00F
A9R1945	321-0963-07		RES,FXD,FILM:98.73K OHM,0.1%,0.125M,TC=T9	07716	CEA 98.73KOHM 1%
A9R1950	313-1103-00		RES,FXD,FILM:10K OHM,5%,0.2M	57668	TR20JE10K0
A9R1951	313-1220-00		RES,FXD,FILM:22 OHM,5%,0.2M	57668	TR20JE22E
A9R1952	313-0202-00		RES,FXD,FILM:2K OHM,5%,0.166M	80009	313-0202-00
A9R1953	313-1393-00		RES,FXD,FILM:39K OHM,5%,0.2M	57668	TR20JE 39K
A9R1971	313-1202-00		RES,FXD,FILM:2K OHM,5%,0.2M	57668	TR20JE02K0
A9R1972	313-1224-00		RES,FXD,FILM:220K,5%,0.2M	57668	TR20JE 220K
A9R1973	313-1124-00		RES,FXD,FILM:120K OHM,5%,0.2M	57668	TR20JE120K
A9R1990	321-0693-00		RES,FXD,FILM:68.1K OHM,0.5%,0.125M,TC=TO	19701	5033RD6812DB2980
A9R1991	315-0107-00		RES,FXD,FILM:100M OHM,5%,0.25M	01121	CB1075
A9R1992	313-1394-00		RES,FXD,FILM:390K,5%,0.2M	57668	TR20JE 390K
A9R1994	321-0402-00		RES,FXD,FILM:150K OHM,1%,0.125M,TC=TO	19701	5033ED150K0F
A9T1970	120-1418-01		XFWR,PMR,SDN&SU:HIGH VOLTAGE	80009	120-1418-01
A9U1062	156-0411-02		MICROCKT,LINER:QUAD COMPARATOR,SCREENED	04713	LM339J05
A9U1830	152-0805-00		SEMICOND DVC,DI:HV MULTR,4.67KV IN,14KV OUT	S4431	MSR8506
A9U1890	156-1191-01		MICROCKT,LINER:DUAL BI-FET OP-AMP,8 DIP	80009	156-1191-01
A9U1956	156-0158-07		MICROCKT,LINER:DUAL OPNL AMPL,SCREENED	01295	MC1458JG4
A9VR1891	152-0282-00		SEMICOND DVC,DI:ZEN,SI,30V,5%,0.4M,00-7	04713	SZ635009K13
A9W900	198-4603-01		WIRE SET,ELEC:M/CRT SOCKET	80009	198-4603-01
A9W1909	131-0566-00		BUS,COND:DUMMY RES,0.094 OD X 0.225L	24546	0MA 07
A14	670-8000-00		CIRCUIT BD ASSY:DYNAMIC CENTERING	80009	670-8000-00
A14C3401	281-0775-00		CAP,FXD,CER DI:0.1UF,20%,50V	04222	MA205E104MAA
A14J141	131-0608-00		TERMINAL,PIN:0.365 L X 0.025 BRZ GLD PL (QUANTITY OF 5)	22526	48283-036

2455A Replaceable Electrical Parts
2445A/2455A Service

Component No.	Tektronix Part No.	Serial/Assembly No. Effective Dscont	Name & Description	Mfr. Code	Mfr. Part No.
A14R3401	311-1137-00		RES,VAR,NONNM:TRMR,5K OHM,0.5M	01121	E2C502
A14R3402	313-1222-00		RES,FXD,FILM:2.2K OHM,5%,0.2M	57668	TR20JE 02K2
A14R3403	313-1750-00		RES,FXD,FILM:75 OHM,5%,0.2M	57668	TR20JE 75E
A14R3404	321-0284-00		RES,FXD,FILM:8.87K OHM,1%,0.125M,TC=TO	19701	5043ED8K870F
A14R3405	313-1750-00		RES,FXD,FILM:75 OHM,5%,0.2M	57668	TR20JE 75E
A14R3407	311-1137-00		RES,VAR,NONNM:TRMR,5K OHM,0.5M	01121	E2C502
A14R3408	321-0284-00		RES,FXD,FILM:8.87K OHM,1%,0.125M,TC=TO	19701	5043ED8K870F
A14R3409	313-1222-00		RES,FXD,FILM:2.2K OHM,5%,0.2M	57668	TR20JE 02K2
A14R3410	313-1103-00		RES,FXD,FILM:10K OHM,5%,0.2M	57668	TR20JE10K0
A14R3411	313-1103-00		RES,FXD,FILM:10K OHM,5%,0.2M	57668	TR20JE10K0
A14U3401	156-0130-00		MICROCKT,LINEAR:MODULATOR/DEMODULATOR	80009	156-0130-00
A14U3402	156-0130-00		MICROCKT,LINEAR:MODULATOR/DEMODULATOR	80009	156-0130-00
A14VR3401	152-0227-00		SEMICONO DVC,DI:ZEN,SI,6.2V,5%,0.4M,00-7	04713	SZ13903
C10	281-0697-00		CAP,FXD,CER DI:5000PF,+100-0%,100V	72982	2425-003M5M0502I
F90	159-0021-00		FUSE,CARTRIDGE:3AG,2A,250V,FAST BLOW	71400	AGC-CN-2
L90	119-1478-01		COIL,TUBE DEFL:FXD,TRACE ROTATION	80009	119-1478-01
S90	260-1967-00		SWITCH,SLIDE:DPDT 5A/250V 10A/125V MKD	TK0935	4021.0512
V900	154-0850-01		CRT ASSEMBLY:FINISHED 2445	80009	154-0850-01

DIAGRAMS AND CIRCUIT BOARD ILLUSTRATIONS

Symbols

Graphic symbols and class designation letters are based on ANSI Standard Y32.2-1975.

Logic symbology is based on ANSI Y32.14-1973 in terms of positive logic. Logic symbols depict the logic function performed and may differ from the manufacturer's data.

The overline on a signal name indicates that the signal performs its intended function when it is in the low state.

Abbreviations are based on ANSI Y1.1-1972.

Other ANSI standards that are used in the preparation of diagrams by Tektronix, Inc. are:

- Y14.15, 1966 Drafting Practices.
- Y14.2, 1973 Line Conventions and Lettering.
- Y10.5, 1968 Letter Symbols for Quantities Used in Electrical Science and Electrical Engineering.

American National Standard Institute
1430 Broadway
New York, New York 10018

Component Values

Electrical components shown on the diagrams are in the following units unless noted otherwise:

Capacitors = Values one or greater are in picofarads (pF).
Values less than one are in microfarads (μ F).

Resistors = Ohms (Ω).

———— The information and special symbols below may appear in this manual. ————

Assembly Numbers and Grid Coordinates

Each assembly in the instrument is assigned an assembly number (e.g., A20). The assembly number appears on the circuit board outline on the diagram, in the title for the circuit board component location illustration, and in the lookup table for the schematic diagram and corresponding component locator illustration. The Replaceable Electrical Parts list is arranged by assemblies in numerical sequence; the components are listed by component number *(see following illustration for constructing a component number).

The schematic diagram and circuit board component location illustration have grids. A lookup table with the grid coordinates is provided for ease of locating the component. Only the components illustrated on the facing diagram are listed in the lookup table. When more than one schematic diagram is used to illustrate the circuitry on a circuit board, the circuit board illustration may only appear opposite the first diagram on which it was illustrated; the lookup table will list the diagram number of other diagrams that the circuitry of the circuit board appears on.

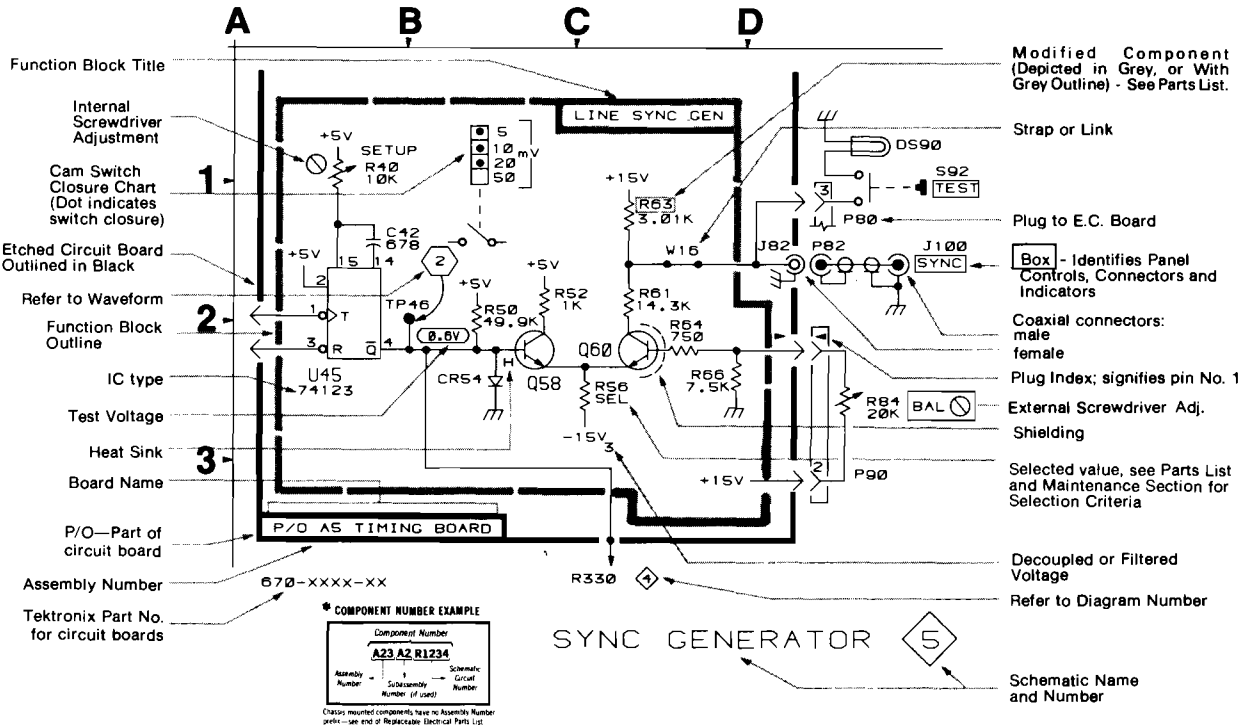

COLOR CODE

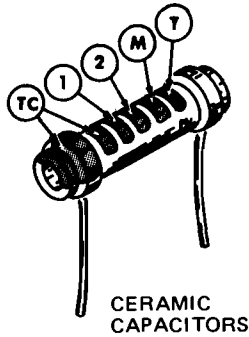
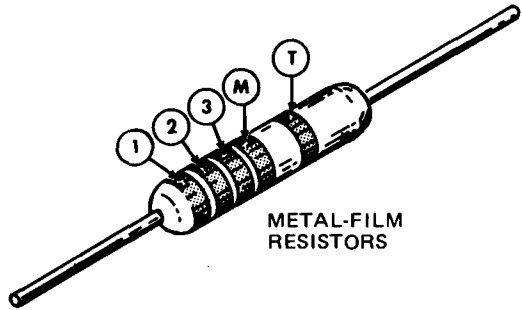
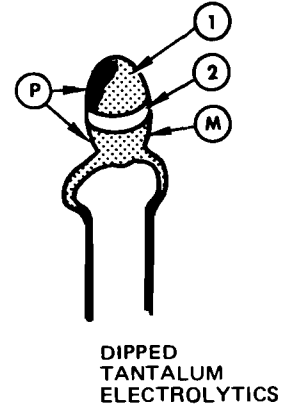
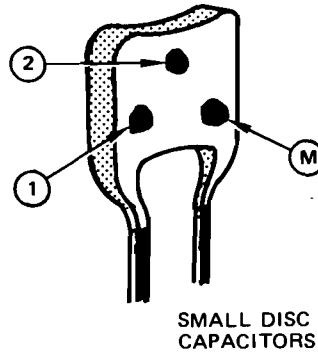
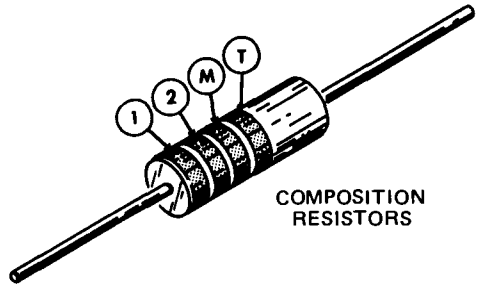

① ② and ③ - 1st, 2nd, and 3rd significant figures

Ⓜ - multiplier Ⓣ - tolerance

ⓉⓈ - temperature coefficient

Ⓟ - polarity and voltage rating

Ⓣ and/or ⓉⓈ color code may not be present on some capacitors

COLOR	SIGNIFICANT FIGURES	RESISTORS		CAPACITORS			DIPPED TANTALUM VOLTAGE RATING
		MULTIPLIER	TOLERANCE	MULTIPLIER	TOLERANCE		
					over 10 pF	under 10 pF	
BLACK	0	1	----	1	±20%	±2 pF	4 VDC
BROWN	1	10	±1%	10	±1%	±0.1 pF	6 VDC
RED	2	10 ² or 100	±2%	10 ² or 100	±2%	----	10 VDC
ORANGE	3	10 ³ or 1 K	±3%	10 ³ or 1000	±3%	----	15 VDC
YELLOW	4	10 ⁴ or 10 K	±4%	10 ⁴ or 10,000	+100% -9%	----	20 VDC
GREEN	5	10 ⁵ or 100 K	±½%	10 ⁵ or 100,000	±5%	±0.5 pF	25 VDC
BLUE	6	10 ⁶ or 1 M	±¼%	10 ⁶ or 1,000,000	----	----	35 VDC
VIOLET	7	----	±1/10%	----	----	----	50 VDC
GRAY	8	----	----	10 ⁻² or 0.01	+80% -20%	±0.25 pF	----
WHITE	9	----	----	10 ⁻¹ or 0.1	±10%	±1 pF	3 VDC
GOLD	-	10 ⁻¹ or 0.1	±5%	----	----	----	----
SILVER	-	10 ⁻² or 0.01	±10%	----	----	----	----
NONE	-	----	±20%	----	±10%	±1 pF	----

(1861-20A) 2662-48

Figure 10-1. Color codes for resistors and capacitors.

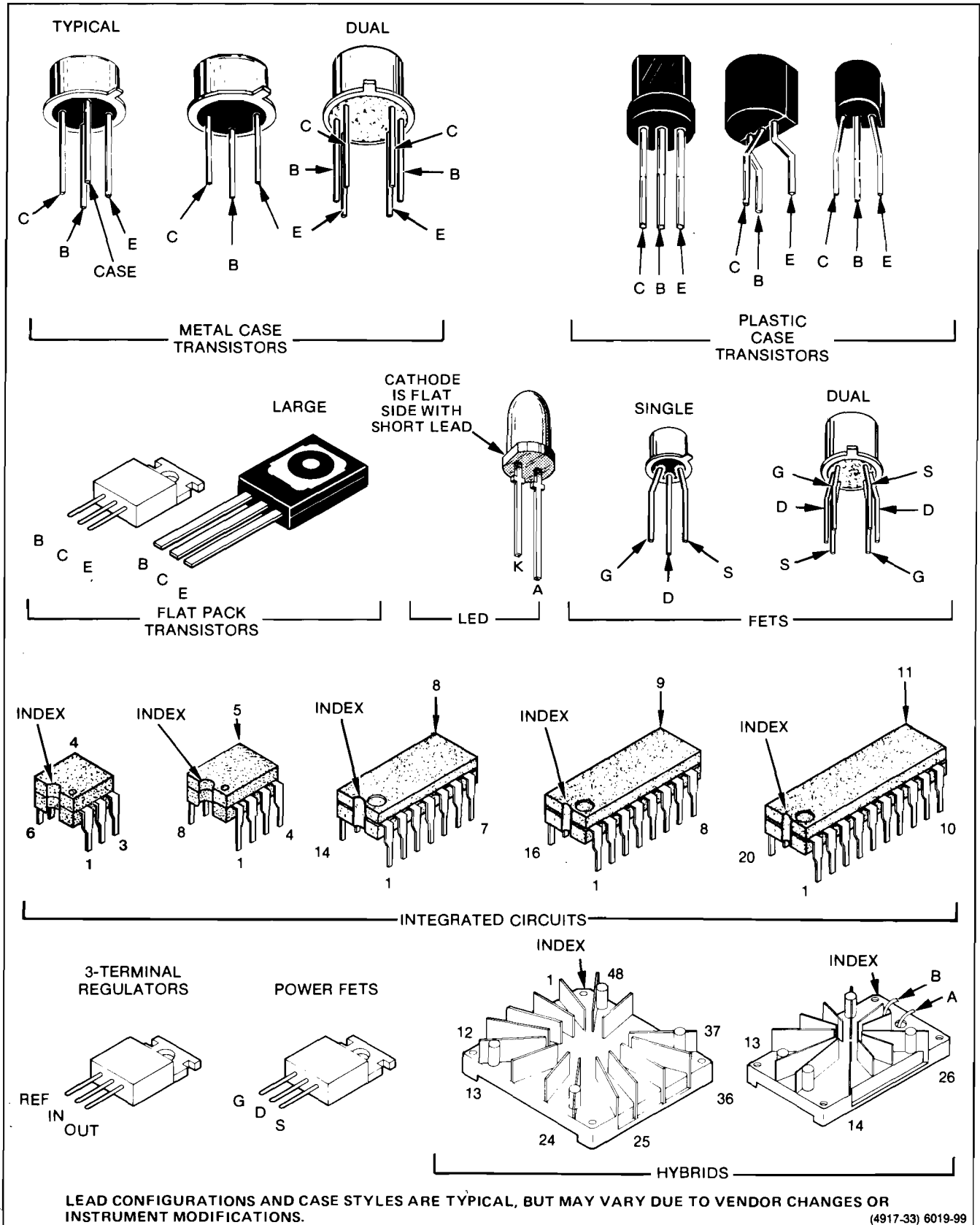

Figure 10-2. Semiconductor lead configurations.

2445A/2455A Service

To identify any component mounted on a circuit board and to locate that component in the appropriate schematic diagram

1. Locate the Circuit Board Illustration

- a. In the instrument identify the Assembly Number of the circuit board in question. The Assembly Number is usually printed on the upper left corner of the circuit board on the component side.
- b. In the manual locate and pull out tabbed page whose title corresponds with the Assembly Number of the circuit board. Circuit board assembly numbers and board nomenclature are printed on the back side of the tabs (facing the rear of the manual).

2. Determine the Circuit Number

- a. Compare the circuit board with its illustration and locate the desired component by area and shape on the illustration.
- b. Scan the table adjacent to the Circuit Board Illustration and find the Circuit Number of the desired component.
- c. Determine the Schematic Diagram Number in which the component is located.

A6 CRT BOARD

COMPONENTS LOCATED ON SCHEMATIC DIAGRAM 10			
C602	Q632	Q658	R625
C603	C641	R626	R627
C609	C643	R604	R627
C671	C651	R605	R630
C615		R608	R632
C616	Q606	R609	
C617	Q610	R610	
C618	Q615	R614	
C619	Q645	R616	
C624	Q656	R623	
C626	Q665	R624	

COMPONENTS LOCATED ON SCHEMATIC DIAGRAM 11			
C670	Q670	R677	
C671	Q672	R679	
C673	Q673	R680	
C680			
C681	R671	U617	
P603	R673	U618	
P607	R674	U619	
Q669	R675		

COMPONENT LOCATION TABLE

CRT CIRCUIT DIAGRAM 10

A6 ASSEMBLY					
CIRCUIT NUMBER	SCHEM LOCATION	BOARD LOCATION	CIRCUIT NUMBER	SCHEM LOCATION	BOARD LOCATION
C602	2C	3C	Q656	2F	2B
C603	1C	1G	Q665	1G	1B
C609	4E	2D	Q668	2G	2B
C612	7C	3E			
C615	7C	3D	R604	4C	1E
C616	2C	3C	R605	5D	1E
C617	7D	3D	R608	4E	1D
C618	7E	3E	R609	4E	2D
C619	6E	3C	R610	7B	3E
C624	4F	3D	R614	7C	3D
C626	7G	2D	R616	1C	3D
C632	8G	1F	R623	4D	2E
C643	3D	4B	R625	7F	2D
C651	3E	3B	R626	7F	2D
			R627	7G	1D
			R630	4F	1D

Q605					
Q606	4E	2D			
Q610	7C	3D	TP624	3B	2D
Q615	7D	3D			
Q645	3E	3B	U615	1D	3C

CHASSIS MOUNTED PARTS					
CIRCUIT NUMBER	SCHEM LOCATION	BOARD LOCATION	CIRCUIT NUMBER	SCHEM LOCATION	BOARD LOCATION
L635	51	CHASSIS	V635	6J	CHASSIS

MANUAL BINDER

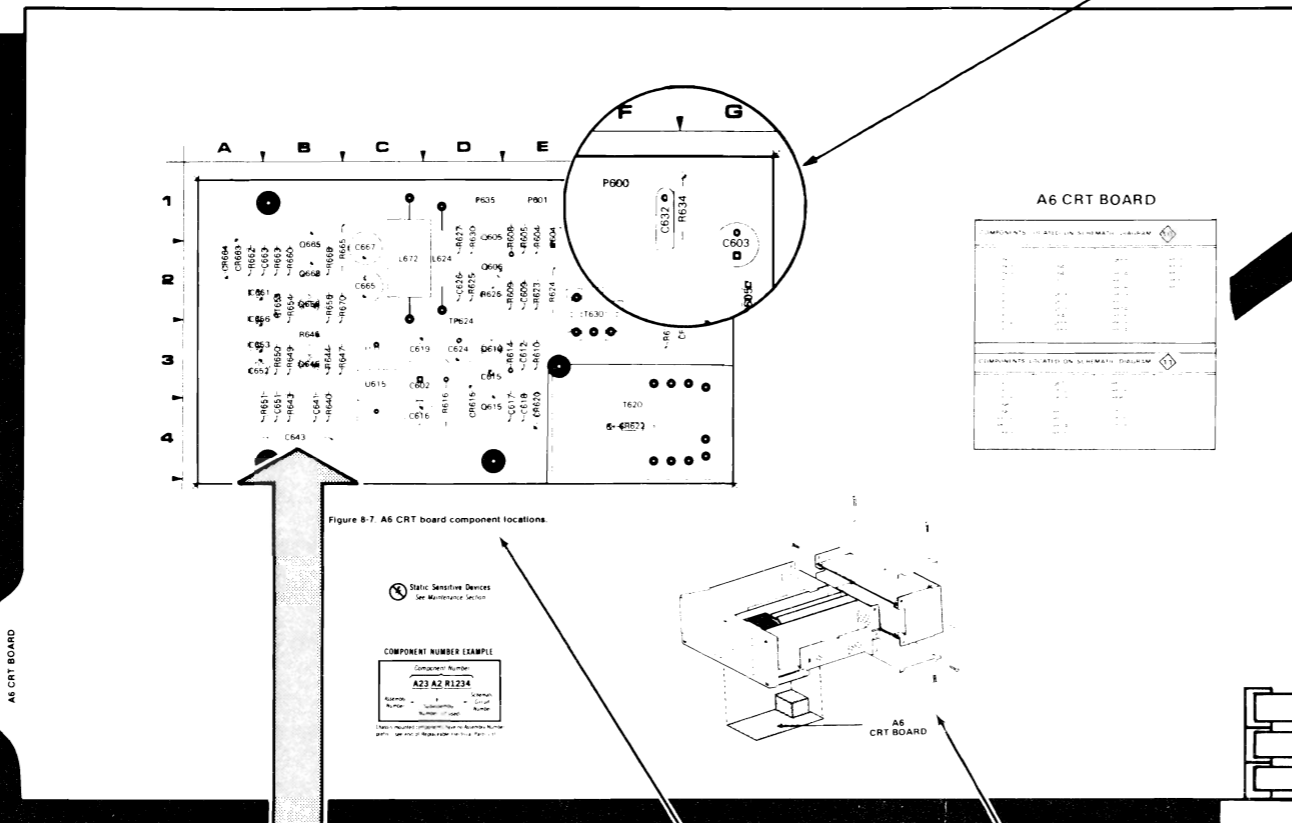

PULL OUT PAGE TABS FOR CIRCUIT BOARD ILLUSTRATION

5. Locate the Component on the Circuit Board

- a. In the manual, locate and pull out the tabbed page whose title and Assembly Number correspond with the desired circuit board. This information is on the back side of the tabs.
- b. Using the Circuit Number and grid coordinates, locate the component on the Circuit Board Illustration.
- c. In the circuit board location illustration, determine the location of the circuit board in the instrument.
- d. Find the circuit board in the instrument and compare it with its illustration in the manual to locate the desired component on the board.

4. Determine the Circuit Board Illustration and Component Location

- a. From the schematic diagram, determine the Assembly Number of the circuit board on which the component is mounted. This information is boxed and located in a corner of the heavy line that distinguishes the board outline.
- b. Scan the Component Location Table for the Assembly Number just determined and find the Circuit Number of the desired component.
- c. Under the BOARD LOCATION column, read the grid coordinates for the desired component.

Figure 10-3. Locating components on schematic diagrams and circuit board illustrations.

Determine the Circuit Number

- Compare the circuit board with its illustration and locate the desired component by area and shape on the illustration.
- Scan the table adjacent to the Circuit Board Illustration and find the Circuit Number of the desired component.
- Determine the Schematic Diagram Number in which the component is located.

3. Locate the Component on the Schematic Diagram

- Locate and pull out tabbed page whose number and title correspond with the Schematic Diagram Number just determined in the table. Schematic diagram nomenclature and numbers are printed on the front side of the tabs (facing the front of the manual).
- Scan the Component Location Table adjacent to the schematic diagram and find the Circuit Number of the desired component.
- Under the SCHEM LOCATION column, read the grid coordinates for the desired component.
- Using the Circuit Number and grid coordinates, locate the component on the schematic diagram.

A6 CRT BOARD

COMPONENTS LOCATED ON SCHEMATIC DIAGRAM 10

C602	C632	Q668	R625
C603	C641	R626	R626
C609	C643	R627	R627
C615	C651	R630	R630
C616	O606	R608	R608
C617	O610	R609	R609
C618	O615	R610	R610
C619	O645	R614	R614
C624	O656	R616	R616
C626	O665	R623	R623
		R624	R624

COMPONENTS LOCATED ON SCHEMATIC DIAGRAM 11

C670	O670	R677	
C671	O672	R679	
C673	O673	R680	
C680			
C681	R671	U617	
P603	R673	U618	
P607	R674	U619	
Q669	R675		

COMPONENT LOCATION TABLE

CRT CIRCUIT DIAGRAM 10

CIRCUIT NUMBER	SCHEM LOCATION	BOARD LOCATION	CIRCUIT NUMBER	SCHEM LOCATION	BOARD LOCATION
C602	2C	3C	Q656	2F	2B
C603	1C	1G	Q665	1G	1B
C609	4E	2C	Q668	2G	2B
C612	7C	3E			
C615	7C	3D	R604	4C	1E
C616	2C	3C	R605	5D	1E
C617	7D	3D	R608	4E	1D
C618	7E	3E	R609	4E	2D
C619	6E	3C	R610	7B	3E
C624	4F	3D	R614	7C	3D
C626	7G	2D	R616	1C	3D
C632	8G	1F	R623	4D	2E
C643	3D	4B	R625	7F	2D
C651	3E	3B	R626	7F	2D
			R627	7G	1D
			R630	4E	1D

CHASSIS MOUNTED PARTS

CIRCUIT NUMBER	SCHEM LOCATION	BOARD LOCATION	CIRCUIT NUMBER	SCHEM LOCATION	BOARD LOCATION
Q605					
Q606	4E	2D	TP624	3B	2D
Q610	7C	3D			
Q615	7D	3D	U615	1D	3C
Q645	3E	3B			

CHASSIS MOUNTED PARTS

CIRCUIT NUMBER	SCHEM LOCATION	BOARD LOCATION	CIRCUIT NUMBER	SCHEM LOCATION	BOARD LOCATION
L635	51	CHASSIS	V635	6J	CHASSIS

CRT CIRCUIT DIAGRAM 10

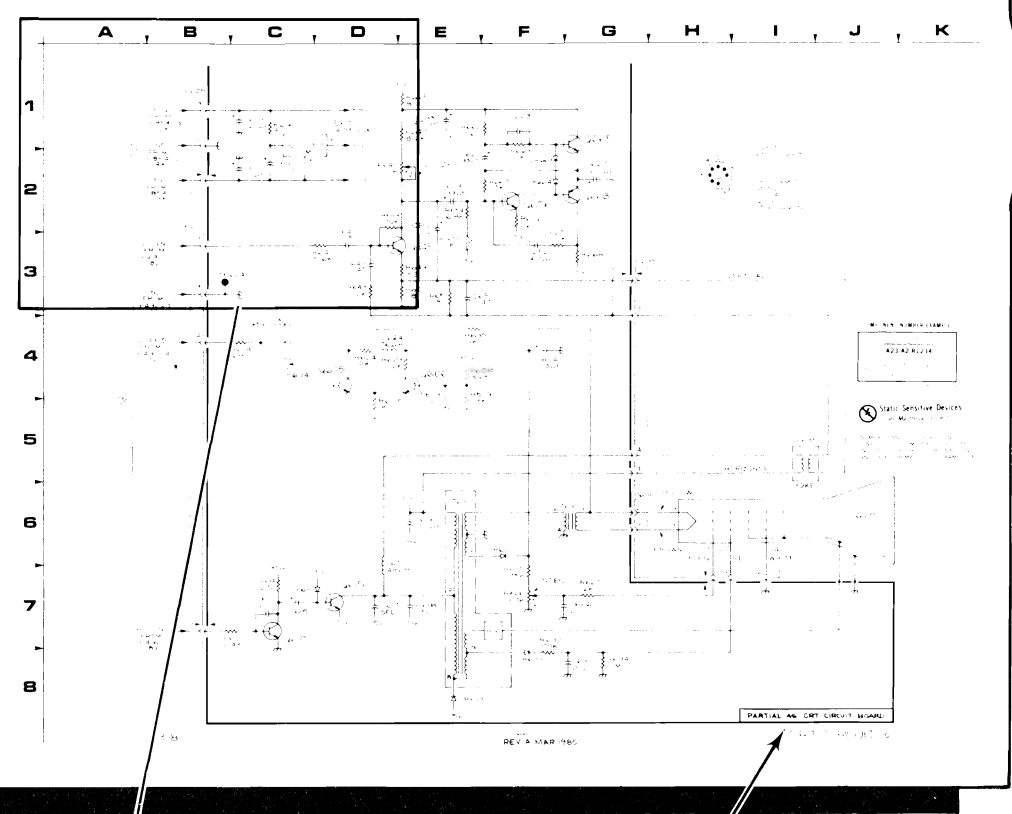

PARTIAL A6 CRT CIRCUIT BOARD

CRT CIRCUIT 10

SCHEMATIC DIAGRAM NAME AND NUMBER

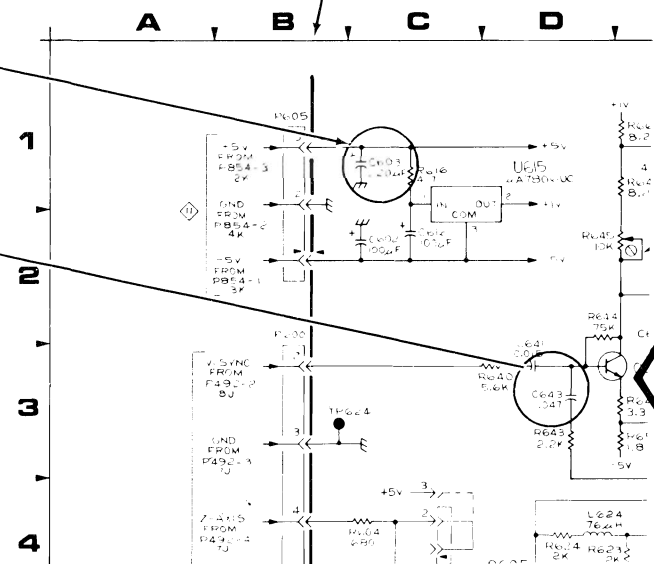

To identify any component in a schematic diagram and to locate that component on its respective circuit board.

Board Illustration and Component

diagram, determine the Assembly board on which the component is located. The component location is boxed and located in a corner of the illustration that distinguishes the board outline.

Component Location Table for the Assembly board and find the Circuit Number of the desired component.

Under the SCHEM LOCATION column, read the grid coordinates for the desired component.

Locate components on schematic diagrams and circuit board illustrations.

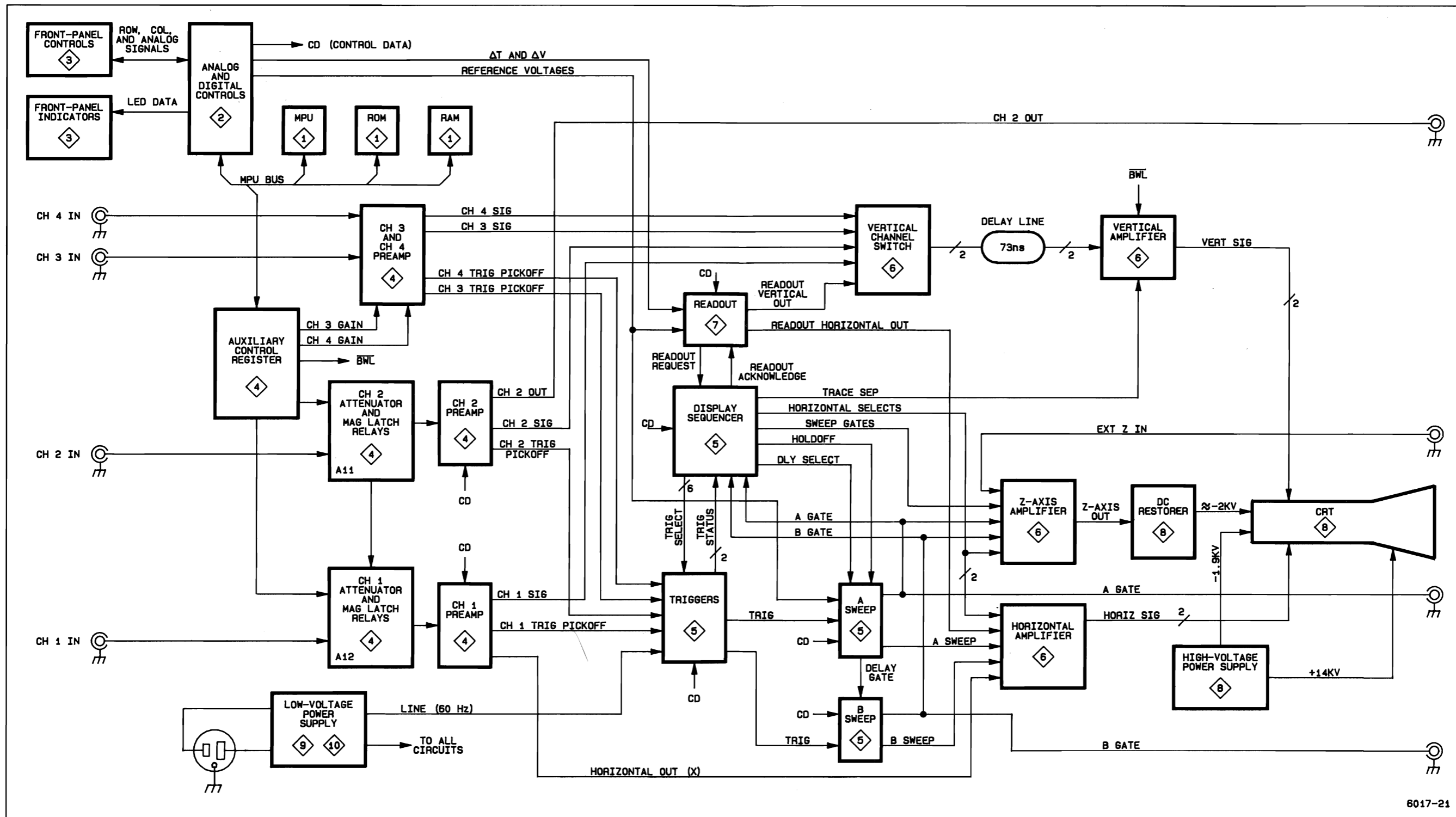

BLOCK DIAGRAM
FIG. 10-4

Figure 10-4. Instrument block diagram.

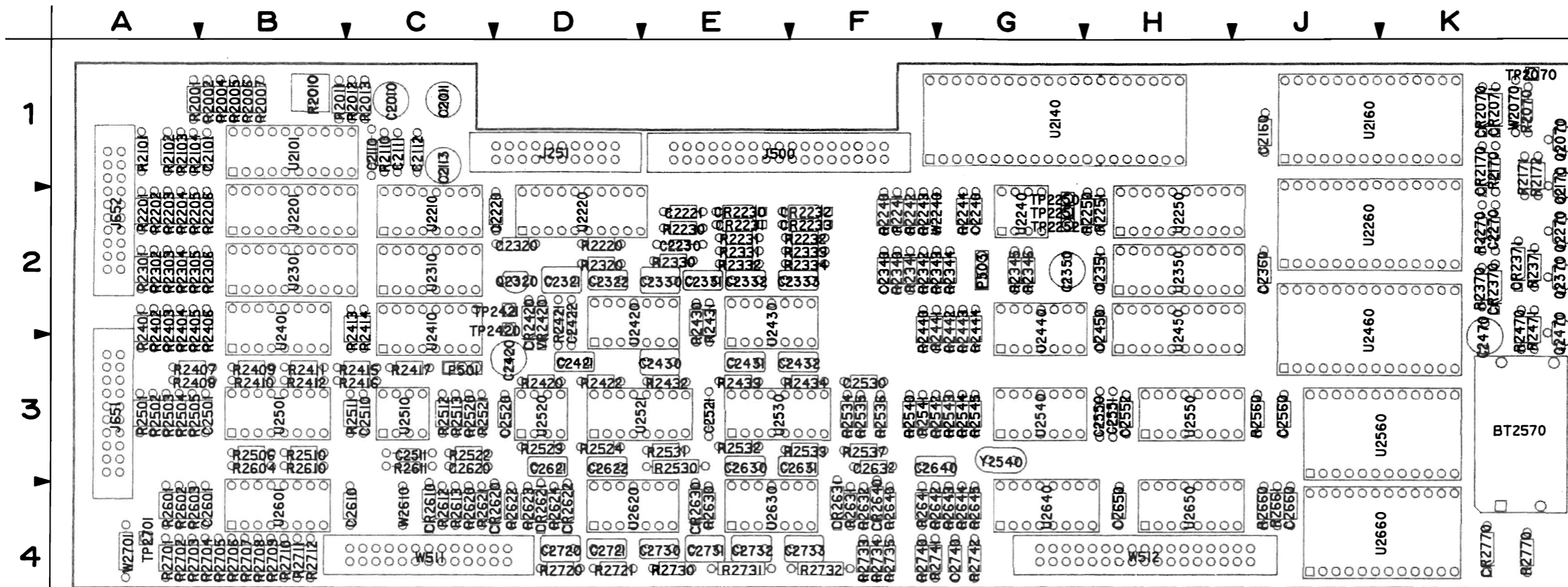
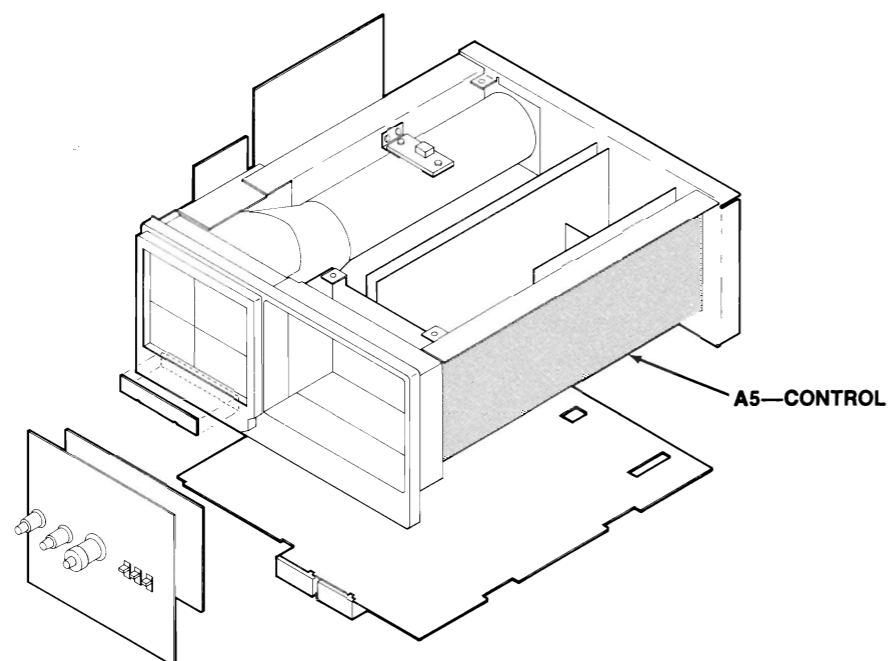

Figure 10-5. A5—Control board.

(6019-94) 6017-17



 Static Sensitive Devices
See Maintenance Section

COMPONENT NUMBER EXAMPLE

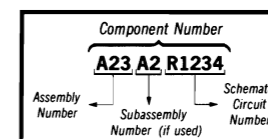

Chassis-mounted components have no Assembly Number prefix—see end of Replaceable Electrical Parts List.

A5—CONTROL BOARD

CIRCUIT NUMBER	SCHEM NUMBER	CIRCUIT NUMBER	SCHEM NUMBER	CIRCUIT NUMBER	SCHEM NUMBER	CIRCUIT NUMBER	SCHEM NUMBER	CIRCUIT NUMBER	SCHEM NUMBER
8T2570	1	CR2420	2	R2320	2	R2540	2	U2210	2
C2010	2	CR2610	2	R2330	2	R2541	1	U2210	12
C2011	12	CR2620	2	R2331	2	R2542	1	U2220	2
C2101	12	CR2621	2	R2332	2	R2543	1	U2220	12
C2110	2	CR2622	2	R2333	2	R2544	1	U2240	1
C2111	12	CR2630	2	R2334	2	R2545	1	U2240	12
C2112	12	CR2631	2	R2340	2	R2560	1	U2250	1
C2113	12	CR2640	2	R2341	2	R2601	2	U2250	12
C2160	12	CR2770	1	R2342	1	R2602	2	U2260	1
C2220	12	J251	1	R2343	1	R2603	2	U2260	12
C2221	12	J251	12	R2344	1	R2604	2	U2301	2
C2230	2	J500	1	R2345	1	R2610	2	U2301	12
C2240	1	J500	1	R2346	1	R2611	2	U2310	1
C2270	1	J651	2	R2370	1	R2612	2	U2310	2
C2320	12	J651	2	R2371	1	R2613	2	U2350	1
C2321	2	J651	2	R2401	2	R2620	2	U2350	1
C2322	2	J652	1	R2402	2	R2621	2	U2401	2
C2330	2	J652	2	R2403	2	R2622	2	U2401	12
C2331	12	J652	12	R2404	2	R2623	2	U2410	2
C2332	2	P501	2	R2405	2	R2624	2	U2410	12
C2333	2	P503	1	R2406	2	R2630	2	U2420	2
C2340	1	Q2070	1	R2407	2	R2631	2	U2420	12
C2350	1	Q2170	1	R2408	2	R2632	2	U2430	2
C2351	1	Q2270	1	R2409	2	R2640	2	U2430	12
C2360	1	Q2320	2	R2410	2	R2641	2	U2440	1
C2420	2	Q2370	1	R2411	2	R2642	2	U2440	12
C2421	2	Q2470	1	R2412	2	R2643	2	U2450	1
C2422	2	R2001	2	R2413	2	R2644	2	U2450	1
C2430	2	R2002	2	R2414	2	R2645	2	U2460	1
C2431	2	R2004	2	R2415	2	R2660	1	U2501	2
C2432	2	R2005	2	R2416	2	R2661	1	U2501	12
C2450	12	R2006	2	R2417	2	R2701	2	U2510	2
C2470	1	R2007	2	R2420	2	R2702	2	U2510	12
C2501	12	R2010	2	R2421	2	R2703	2	U2520	2
C2510	12	R2011	2	R2422	2	R2704	2	U2520	12
C2511	2	R2012	2	R2430	2	R2705	2	U2521	2
C2520	12	R2013	2	R2431	2	R2706	2	U2521	12
C2521	2	R2070	1	R2432	2	R2707	2	U2530	2
C2530	12	R2101	2	R2433	2	R2708	2	U2530	12
C2550	1	R2102	2	R2434	2	R2709	2	U2540	1
C2551	1	R2103	2	R2440	1	R2710	2	U2540	12
C2552	12	R2104	2	R2441	1	R2711	2	U2550	1
C2560	1	R2110	2	R2442	1	R2712	2	U2550	12
C2601	12	R2170	1	R2443	1	R2720	2	U2560	1
C2610	12	R2171	1	R2444	1	R2721	2	U2601	2
C2620	12	R2172	1	R2470	1	R2730	2	U2601	12
C2621	2	R2201	2	R2471	1	R2731	2	U2620	2
C2622	2	R2202	2	R2501	2	R2732	2	U2620	12
C2630	2	R2203	2	R2502	2	R2733	2	U2630	2
C2631	2	R2204	2	R2503	2	R2734	2	U2630	12
C2632	12	R2205	2	R2504	2	R2735	2	U2640	1
C2640	1	R2206	2	R2505	2	R2740	2	U2640	12
C2650	12	R2220	2	R2506	2	R2741	2	U2650	1
C2660	12	R2230	2	R2510	2	R2742	1	U2650	1
C2720	2	R2231	2	R2511	2	R2770	1	U2650	12
C2721	2	R2232	2	R2512	2	TP2070	12	U2660	1
C2730	2	R2240	1	R2513	2	TP2250	1	U2660	12
C2731	2	R2241	1	R2520	2	TP2251	1	VR2420	2
C2732	2	R2242	1	R2521	2	TP2252	1	W511	2
C2733	2	R2243	1	R2522	2	TP2420	2	W511	12
C2740	12	R2244	1	R2523	2	TP2421	2	W512	1
CR2070	1	R2250	1	R2524	2	TP2701	12	W512	2
CR2071	1	R2251	1	R2530	2	U2101	2	W512	2
CR2170	1	R2270	1	R2531	2	U2101	12	W512	12
CR2230	2	R2301	2	R2532	2	U2140	1	W2070	12
CR2231	2	R2302	2	R2533	2	U2140	12	W2240	1
CR2232	2	R2303	2	R2534	2	U2160	1	W2610	12
CR2233	2	R2304	2	R2535	2	U2160	12	W2701	12
CR2370	1	R2305	2	R2536	2	U2201	2	Y2540	1
CR2371	1	R2306	2	R2537	2	U2201	12		

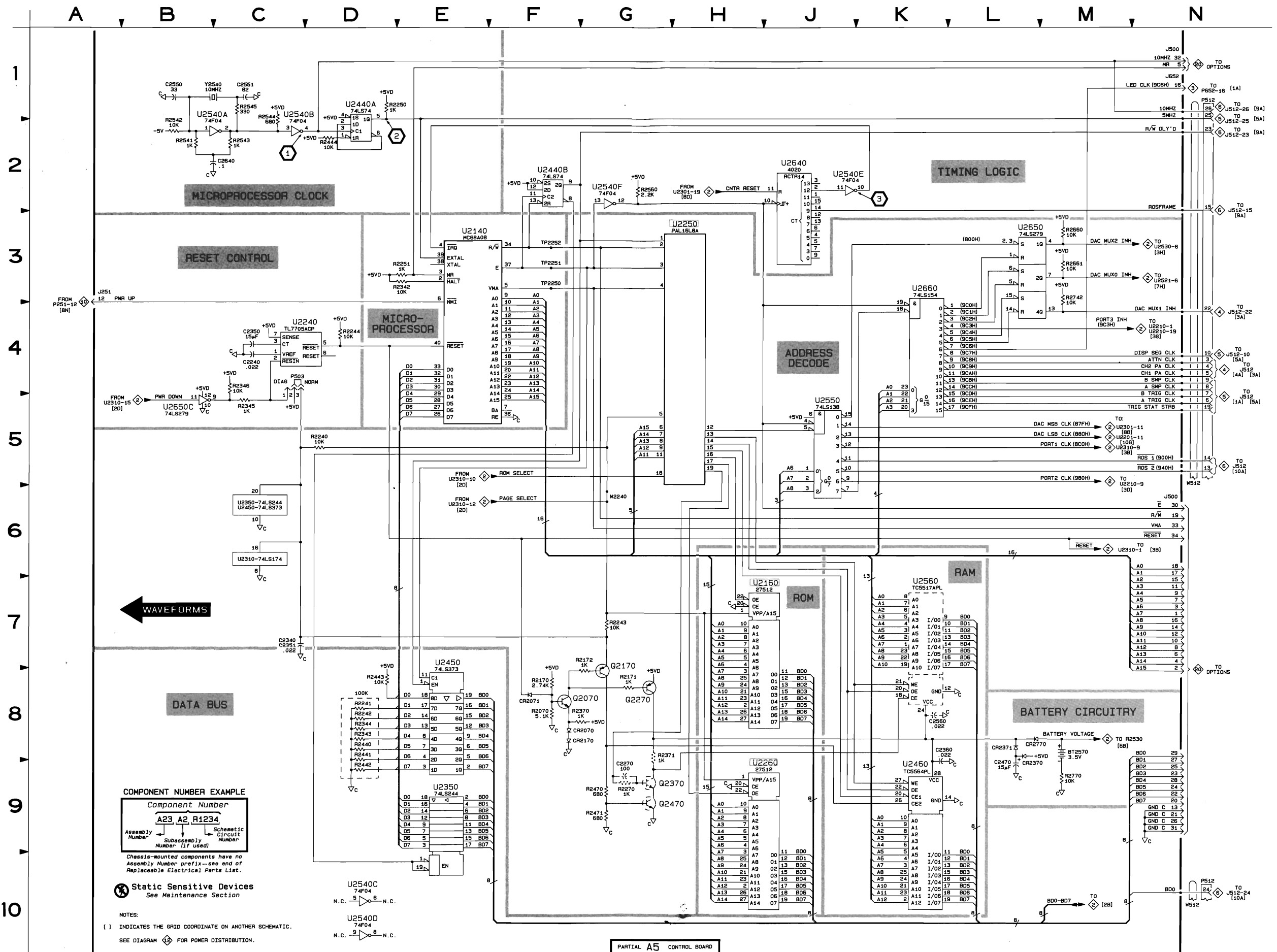

PROCESSOR & DIGITAL CONTROL

ANALOG CONTROL DIAGRAM 2

ASSEMBLY A5											
CIRCUIT NUMBER	SCHEM LOCATION	BOARD LOCATION	CIRCUIT NUMBER	SCHEM LOCATION	BOARD LOCATION	CIRCUIT NUMBER	SCHEM LOCATION	BOARD LOCATION	CIRCUIT NUMBER	SCHEM LOCATION	BOARD LOCATION
C2010	10E	1C	R2011	10E	1B	R2502	6D	3A	R2721	8J	4D
C2110	10F	1C	R2012	10E	1C	R2503	6D	3A	R2730	7J	4E
C2230	6M	2E	R2013	10E	1C	R2504	6D	3A	R2731	4J	4E
C2321	6J	2D	R2101	10N	1A	R2505	6D	3A	R2732	4L	4F
C2322	5J	2D	R2102	10N	1A	R2506	6D	3B	R2733	4K	4F
C2330	6J	2E	R2103	9N	1A	R2510	2F	3B	R2734	3L	4F
C2332	2J	2E	R2104	9N	1A	R2511	3F	3C	R2735	4M	4F
C2333	3J	2F	R2110	3E	1C	R2512	3G	3C	R2740	4K	4F
C2420	5M	3D	R2201	7C	2A	R2513	3F	3C	R2741	4M	4F
C2421	6J	3D	R2202	7C	2A	R2520	5J	3C			
C2422	5L	2D	R2203	7D	2A	R2521	5K	3C	TP2420	5M	2D
C2430	6J	3E	R2204	7D	2A	R2522	7L	3C	TP2421	5M	2D
C2431	2J	3E	R2205	7D	2A	R2523	7K	3D			
C2432	2J	3F	R2206	10C	2B	R2524	7M	3D	U2101	9F	1B
C2511	3G	3C	R2220	5L	2D	R2530	6C	3E	U2201	9C	2B
C2521	6L	3E	R2230	6L	2E	R2531	2M	3E	U2210	2E	2C
C2621	7J	3D	R2231	2M	2E	R2532	4K	3E	U2220	2H	2D
C2622	7J	3D	R2232	3K	2F	R2533	3M	3F	U2301	8C	2B
C2630	4J	3E	R2301	7D	2A	R2534	2L	3F	U2310	2C	2C
C2631	3J	3F	R2302	7D	2A	R2535	2K	3F	U2401	3F	2B
C2720	8J	4D	R2303	7D	2A	R2536	1D	3F	U2410	7F	2C
C2721	8J	4D	R2304	7D	2A	R2537	3M	3F	U2420A	4L	2D
C2730	7K	4E	R2305	7D	2A	R2540	8G	3F	U2420B	6K	2D
C2731	7J	4E	R2306	9C	2B	R2601	4N	4A	U2420C	6M	2D
C2732	3J	4E	R2320	5J	2D	R2602	4D	4A	U2420D	5K	2D
C2733	4J	4F	R2330	6M	2E	R2603	4D	4A	U2430A	2K	2E
			R2331	3M	2E	R2604	6D	3B	U2430B	2M	2E
CR2230	2M	2E	R2332	3L	2E	R2610	2F	3B	U2430C	3K	2E
CR2231	3N	2E	R2333	3K	2F	R2611	3G	3C	U2430D	2M	2E
CR2232	3L	2F	R2334	3K	2F	R2612	7N	4C	U2501	5F	3B
CR2233	3L	2F	R2340	1C	2F	R2613	8N	4C	U2510	3G	3C
CR2420	5M	2D	R2341	1C	2F	R2620	7M	4C	U2520A	7K	3D
CR2610	3N	4C	R2401	3D	2A	R2621	7L	4C	U2520B	6M	3D
CR2620	7L	4C	R2402	3D	2A	R2622	7M	4D	U2521	6J	3E
CR2621	8M	4D	R2403	3D	2A	R2623	8M	4D	U2530	3J	3E
CR2622	8M	4D	R2404	3D	2A	R2624	8M	4D	U2601	4F	4B
CR2630	7K	4E	R2405	4C	2A	R2630	3L	4E	U2620A	8M	4D
CR2631	4N	4F	R2406	4D	2B	R2631	4M	4F	U2620B	7K	4D
CR2640	3N	4F	R2407	3D	3A	R2632	4L	4F	U2620C	6C	4D
			R2408	4D	3A	R2640	4K	4F	U2620D	7M	4D
J651	3A	3A	R2409	4D	3B	R2641	8G	4F	U2630A	3K	4E
J651	4N	3A	R2410	4D	3B	R2642	8H	4F	U2630B	4M	4E
J651	6A	3A	R2411	4D	3B	R2643	8J	4G	U2630C	3M	4E
J652	1N	2A	R2412	4C	3B	R2644	8J	4G	U2630D	4K	4E
J652	7A	2A	R2413	7C	2C	R2645	8J	4G			
J652	9N	2A	R2414	8D	2C	R2701	6D	4A	VR2420	5L	2D
			R2415	2F	3C	R2702	6D	4A			
P501	7E	3C	R2416	7E	3C	R2703	5C	4A	W511	2N	4C
			R2417	7E	3C	R2704	5D	4B	W511	5A	4C
Q2320	4M	2D	R2420	6M	3D	R2705	5D	4B	W511	5N	4C
			R2421	5L	2D	R2706	5D	4B	W512	1N	4H
R2001	10N	1A	R2422	5L	3D	R2707	5D	4B	W512	2A	4H
R2002	10N	1B	R2430	6K	2E	R2708	5D	4B	W512	4N	4H
R2004	10N	1B	R2431	2M	2E	R2709	5D	4B	W512	6A	4H
R2005	10N	1B	R2432	6K	3E	R2710	5C	4B	W512	8N	4H
R2006	10N	1B	R2433	2K	3E	R2711	5D	4B			
R2007	10N	1B	R2434	2M	3F	R2712	5D	4B			
R2010	10E	1B	R2501	6D	3A	R2720	8N	4D			

Partial A5 also shown on diagrams 1 and 12.

OTHER PARTS											
P511	2N	CHASSIS	P511	5N	CHASSIS	P512	1N	CHASSIS	P512	6A	CHASSIS
P511	4A	CHASSIS	P512	1A	CHASSIS	P512	3N	CHASSIS	P512	8N	CHASSIS

A B C D E F G H J K L M N

1
2
3
4
5
6
7
8
9
10

WAVEFORMS

HARDWARE I/O

DMUX & ANALOG CONTROL

POT SCANNING

FRONT PANEL SCANNING

DAC

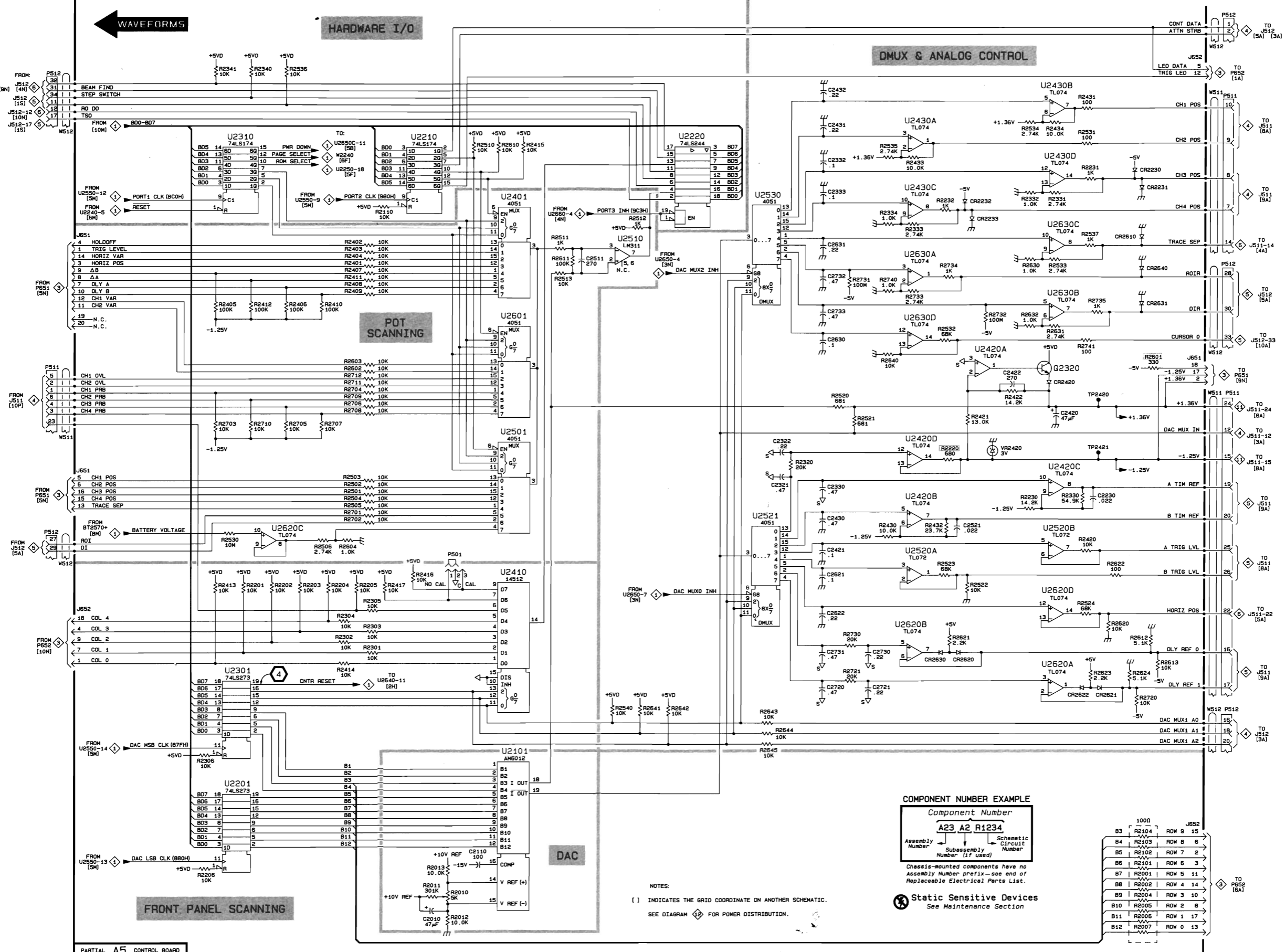

COMPONENT NUMBER EXAMPLE

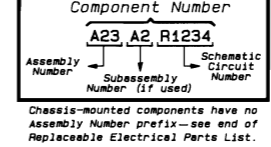

83	R2104	ROW 9 15
84	R2103	ROW 8 6
85	R2102	ROW 7 2
86	R2101	ROW 6 3
87	R2001	ROW 5 11
88	R2002	ROW 4 14
89	R2004	ROW 3 10
90	R2005	ROW 2 8
91	R2006	ROW 1 17
92	R2007	ROW 0 13

NOTES:
[] INDICATES THE GRID COORDINATE ON ANOTHER SCHEMATIC.
SEE DIAGRAM FOR POWER DISTRIBUTION.

Static Sensitive Devices
See Maintenance Section

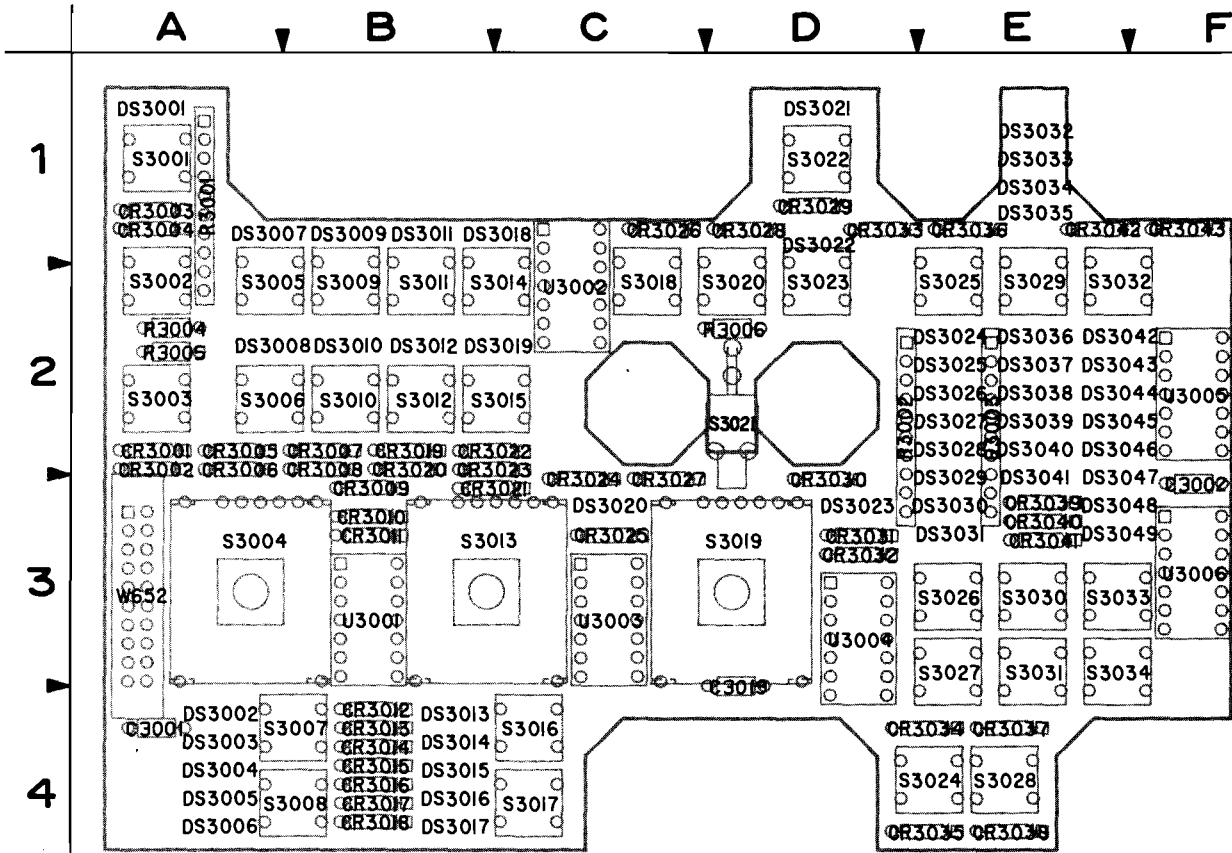
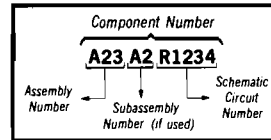

Figure 10-6. A6—Front Panel board.

(6019-93) 6017-19

 Static Sensitive Devices
See Maintenance Section

COMPONENT NUMBER EXAMPLE



Chassis-mounted components have no Assembly Number prefix—see end of Replaceable Electrical Parts List.

A6—FRONT PANEL BOARD

CIRCUIT NUMBER	SCHEM NUMBER	CIRCUIT NUMBER	SCHEM NUMBER	CIRCUIT NUMBER	SCHEM NUMBER	CIRCUIT NUMBER	SCHEM NUMBER
C3001	12	CR3036	3	DS3031	3	S3014	3
C3002	12	CR3037	3	DS3032	3	S3015	3
C3019	12	CR3038	3	DS3033	3	S3016	3
CR3001	3	CR3039	3	DS3034	3	S3017	3
CR3002	3	CR3040	3	DS3035	3	S3018	3
CR3003	3	CR3041	3	DS3036	3	S3019	3
CR3004	3	CR3042	3	DS3037	3	S3020	3
CR3005	3	CR3043	3	DS3038	3	S3021	3
CR3006	3	DS3001	3	DS3039	3	S3022	3
CR3007	3	DS3002	3	DS3040	3	S3023	3
CR3008	3	DS3003	3	DS3041	3	S3024	3
CR3009	3	DS3004	3	DS3042	3	S3025	3
CR3010	3	DS3005	3	DS3043	3	S3026	3
CR3011	3	DS3006	3	DS3044	3	S3027	3
CR3012	3	DS3007	3	DS3045	3	S3028	3
CR3013	3	DS3008	3	DS3046	3	S3029	3
CR3014	3	DS3009	3	DS3047	3	S3030	3
CR3015	3	DS3010	3	DS3048	3	S3031	3
CR3016	3	DS3011	3	DS3049	3	S3032	3
CR3017	3	DS3012	3	R3001	3	S3033	3
CR3018	3	DS3013	3	R3002	3	S3034	3
CR3019	3	DS3014	3	R3003	3	U3001	3
CR3020	3	DS3015	3	R3004	3	U3001	12
CR3021	3	DS3016	3	R3005	3	U3002	3
CR3022	3	DS3017	3	R3006	3	U3002	12
CR3023	3	DS3018	3	S3001	3	U3003	3
CR3024	3	DS3019	3	S3002	3	U3003	12
CR3025	3	DS3020	3	S3003	3	U3004	3
CR3026	3	DS3021	3	S3004	3	U3004	12
CR3027	3	DS3022	3	S3005	3	U3005	3
CR3028	3	DS3023	3	S3006	3	U3005	12
CR3029	3	DS3024	3	S3007	3	U3006	3
CR3030	3	DS3025	3	S3008	3	U3006	12
CR3031	3	DS3026	3	S3009	3	W652	3
CR3032	3	DS3027	3	S3010	3	W652	3
CR3033	3	DS3028	3	S3011	3	W652	12
CR3034	3	DS3029	3	S3012	3		
CR3035	3	DS3030	3	S3013	3		

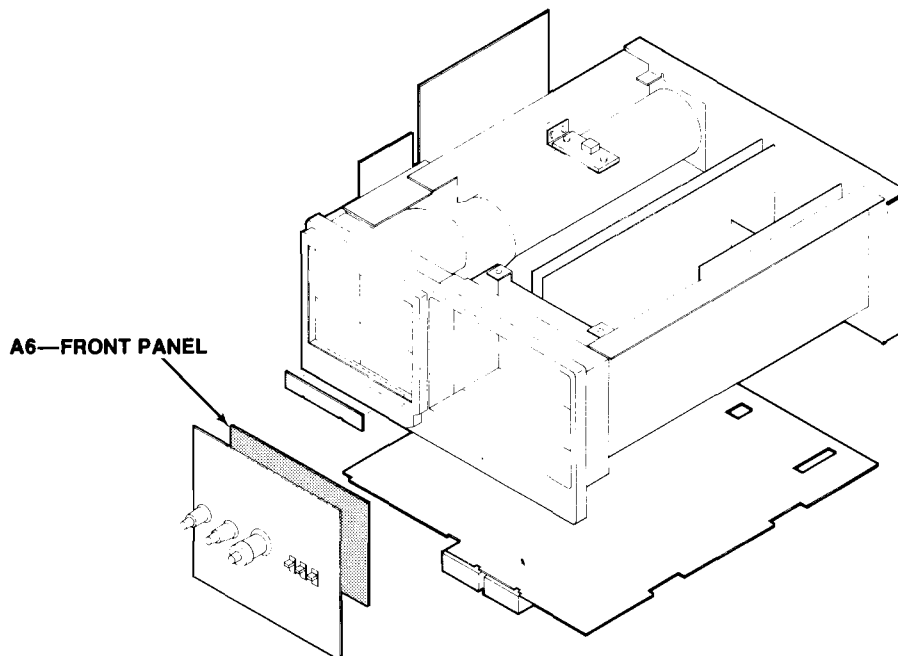

FRONT PANEL CONTROLS DIAGRAM 3

ASSEMBLY A6											
CIRCUIT NUMBER	SCHEM LOCATION	BOARD LOCATION	CIRCUIT NUMBER	SCHEM LOCATION	BOARD LOCATION	CIRCUIT NUMBER	SCHEM LOCATION	BOARD LOCATION	CIRCUIT NUMBER	SCHEM LOCATION	BOARD LOCATION
CR03001	7D	2A	CR3043	3D	1F	DS3041	10K	3E	S3006	6C	2A
CR3002	8D	3A				DS3042	8H	2E	S3007	1C	4B
CR3003	8D	1A	DS3001	2L	1A	DS3043	8H	2E	S3008	1C	4B
CR3004	8D	1A	DS3002	5G	4A	DS3044	8J	2E	S3009	6B	2B
CR3005	4D	2A	DS3003	5G	4A	DS3045	8K	2E	S3010	3D	2B
CR3006	4D	3A	DS3004	5H	4A	DS3046	8K	2E	S3011	6C	2B
CR3007	4D	2B	DS3005	5H	4A	DS3047	4J	3E	S3012	7C	2B
CR3008	4D	3B	DS3006	5J	4A	DS3048	4K	3E	S3013	4C	3B
CR3009	5D	3B	DS3007	2G	1A	DS3049	4K	3E	S3014	6D	2B
CR3010	5D	3B	DS3008	2H	2A				S3015	7D	2B
CR3011	5D	3B	DS3009	2G	1B	R3001	1H	1A	S3016	2D	4C
CR3012	5D	4B	DS3010	2K	2B	R3001	2G	1A	S3017	2C	4C
CR3013	8D	4B	DS3011	2H	1B	R3001	2H	1A	S3018	8C	2C
CR3014	4D	4B	DS3012	2K	2B	R3001	2J	1A	S3019	5C	3D
CR3015	3D	4B	DS3013	5K	4B	R3001	2L	1A	S3020	8C	2D
CR3016	3D	4B	DS3014	5K	4B	R3001	3H	1A	S3021	5D	2D
CR3017	2D	4B	DS3015	5L	4B	R3001	5G	1A	S3022	8B	1D
CR3018	2D	4B	DS3016	7G	4B	R3002	1H	2D	S3023	8B	2D
CR3019	7D	2B	DS3017	7G	4B	R3002	3G	2D	S3024	2B	4E
CR3020	7D	3B	DS3018	2J	1B	R3002	3L	2D	S3025	10D	2E
CR3021	8D	3B	DS3019	4G	2B	R3002	5J	2D	S3026	10C	3E
CR3022	7D	2B	DS3020	4H	3C	R3002	6G	2D	S3027	10C	3E
CR3023	7D	3B	DS3021	4L	1D	R3002	6H	2D	S3028	2B	4E
CR3024	6D	3C	DS3022	4G	1D	R3002	8H	2D	S3029	8D	2E
CR3025	5D	3C	DS3023	4H	3D	R3002	9G	2D	S3030	10B	3E
CR3026	9D	1C	DS3024	7L	2E	R3003	1G	2E	S3031	10B	3E
CR3027	6D	3C	DS3025	7K	2E	R3003	1J	2E	S3032	2C	2E
CR3028	9D	1D	DS3026	7K	2E	R3003	1K	2E	S3033	1B	3E
CR3029	9D	1D	DS3027	7J	2E	R3003	1L	2E	S3034	1B	3E
CR3030	6D	3D	DS3028	10K	2E	R3003	6H	2E			
CR3031	6D	3D	DS3029	8G	3E	R3003	9G	2E	U3001	5F	3B
CR3032	10D	3D	DS3030	8G	3E	R3003	9H	2E	U3002	2F	2C
CR3033	9D	1D	DS3031	10L	3E	R3003	9J	2E	U3003	4F	3C
CR3034	10D	4E	DS3032	1F	1E	R3004	2K	2A	U3004	7F	3D
CR3035	3D	4E	DS3033	7H	1E	R3005	2K	2A	U3005	8F	2F
CR3036	10D	1E	DS3034	8L	1E	R3006	3H	2D	U3006	10F	3F
CR3037	10D	4E	DS3035	7H	1E				W652	10A	3A
						S3001	7B	1A	W652	10N	3A
CR3038	3D	4E	DS3036	10G	2E	S3002	7B	2A			
CR3039	2D	3E	DS3037	10G	2E	S3003	7C	2A			
CR3040	10D	3E	DS3038	10H	2E	S3004	3C	3A			
CR3041	2D	3E	DS3039	10H	2E	S3005	6B	2A			
CR3042	9D	1E	DS3040	10J	2E						
Partial A6 also shown on diagram 12.											
OTHER PARTS											
P651	1N	CHASSIS	R3008	2M	CHASSIS	R3013	8M	CHASSIS	R3018	6M	CHASSIS
P652	10N	CHASSIS	R3009	4M	CHASSIS	R3014	2M	CHASSIS	R3019	4M	CHASSIS
P652	1A	CHASSIS	R3010	7M	CHASSIS	R3015	1M	CHASSIS			
			R3011	6M	CHASSIS	R3016	7M	CHASSIS	W651	9N	CHASSIS
R3007	5M	CHASSIS	R3012	5M	CHASSIS	R3017	3M	CHASSIS			

A B C D E F G H J K L M N

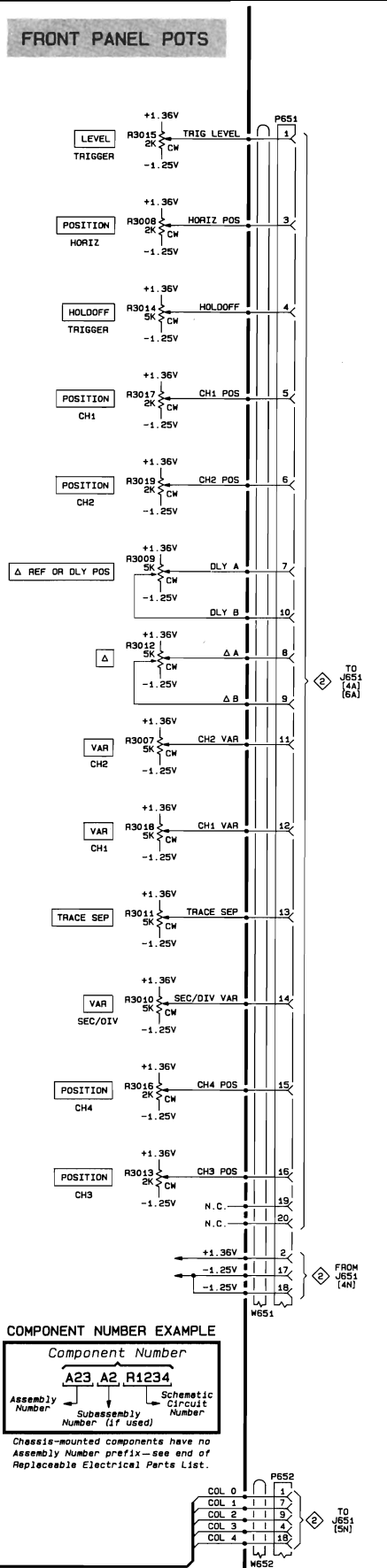
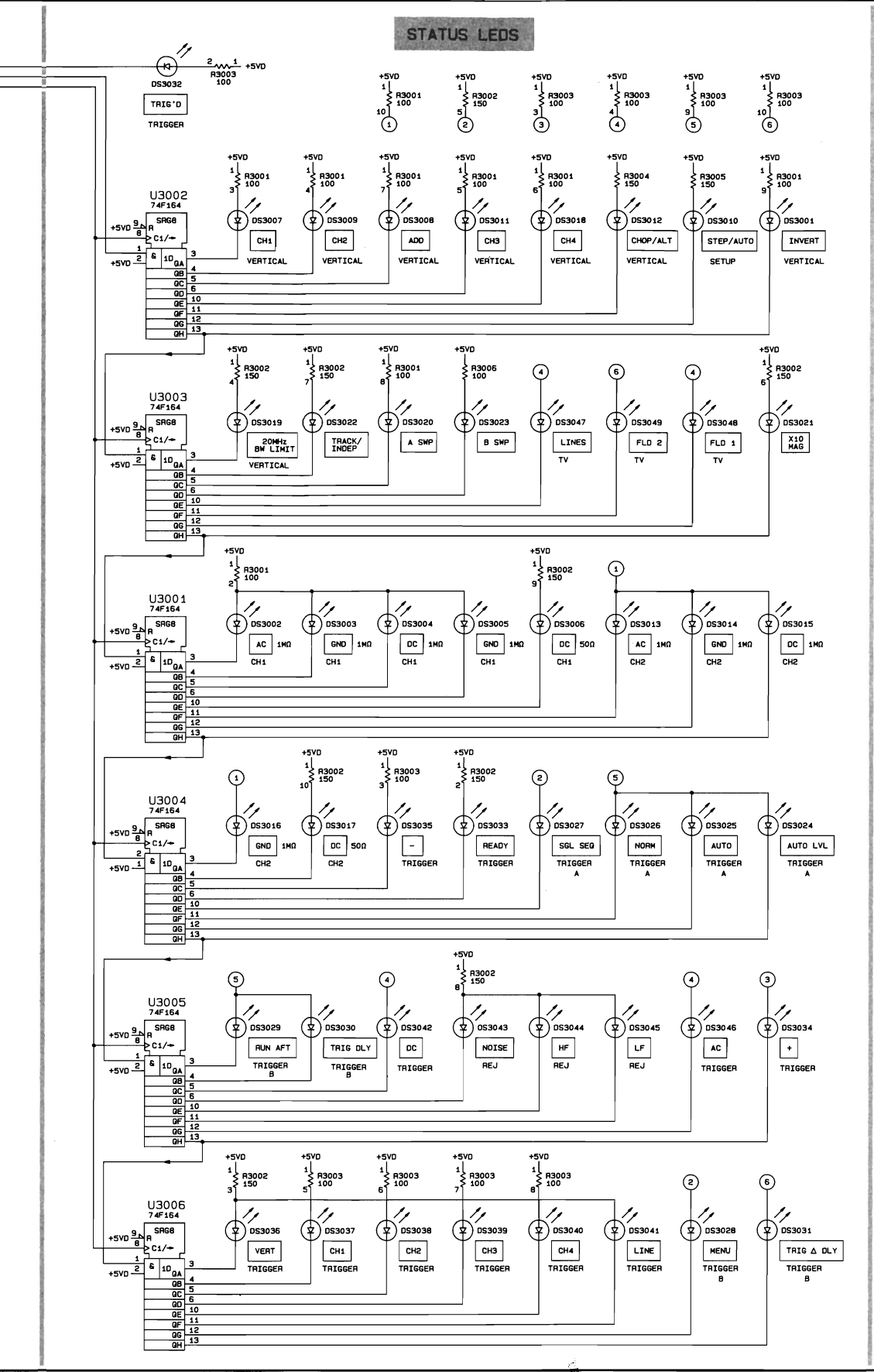
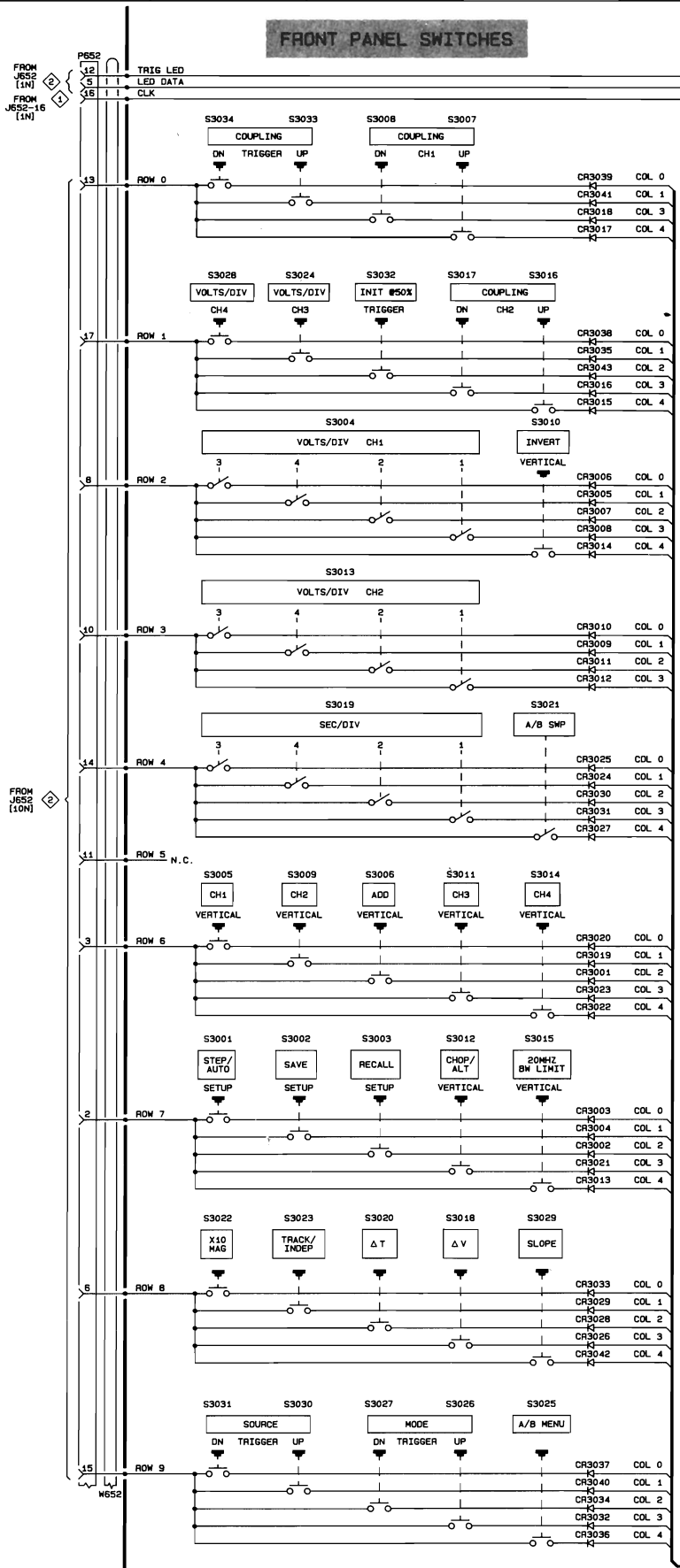

COMPONENT NUMBER EXAMPLE

Component Number
A23 A2 R1234

Assembly Number Schematic Circuit Number
 Subassembly Number (if used)

Chassis-mounted components have no Assembly Number prefix—see end of Replaceable Electrical Parts List.

Static Sensitive Devices
 See Maintenance Section

FRONT PANEL CONTROLS

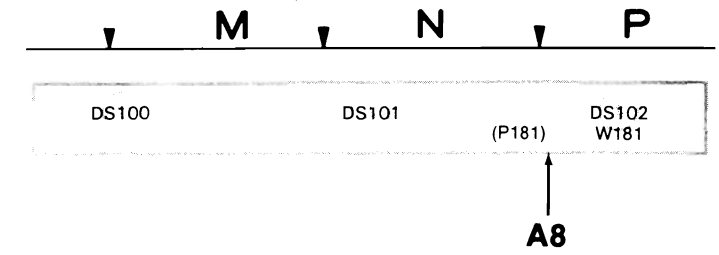
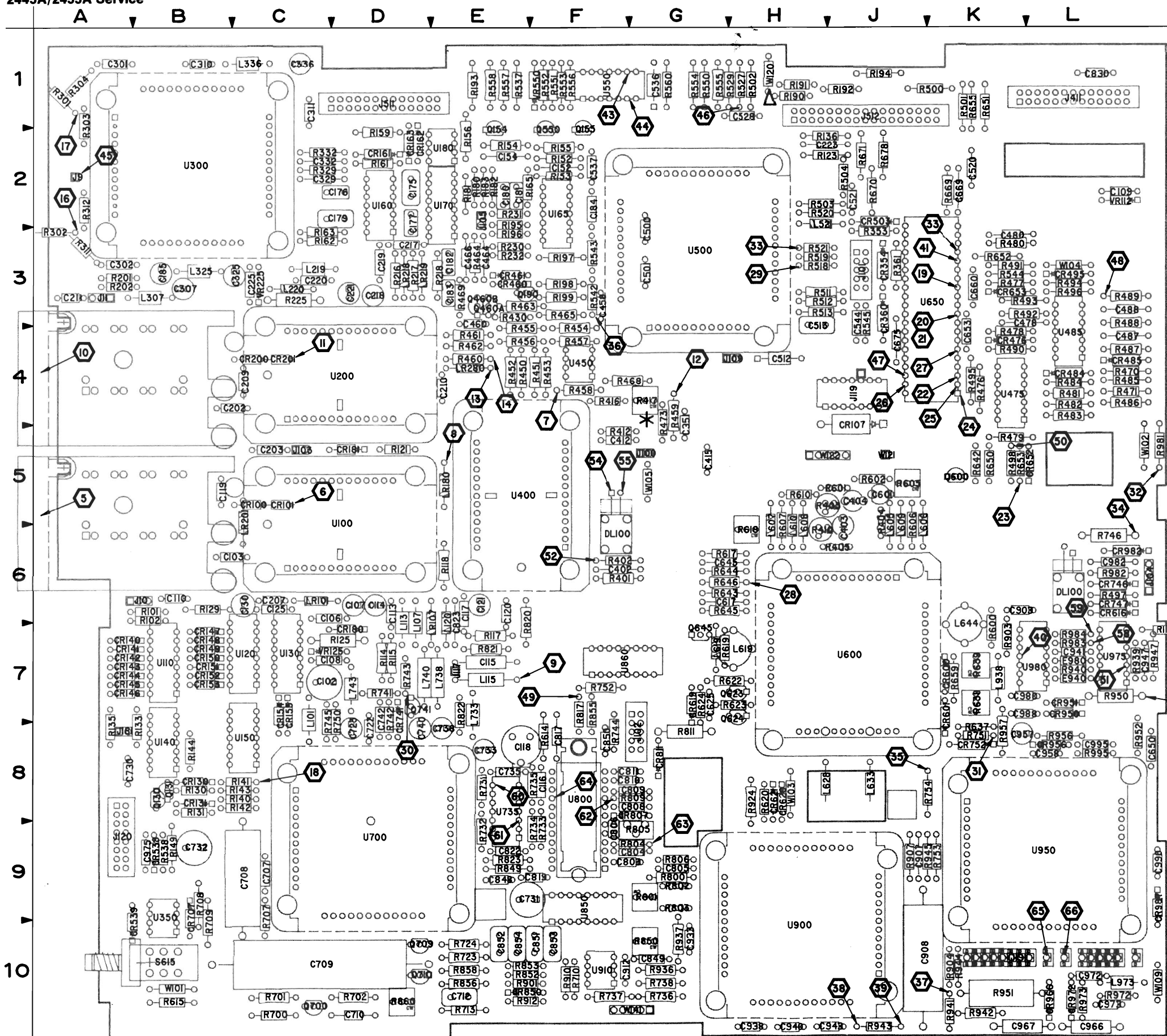

* 2455A ONLY (1)
 ▲ 2445A ONLY (1)

A8—SCALE ILLUMINATION

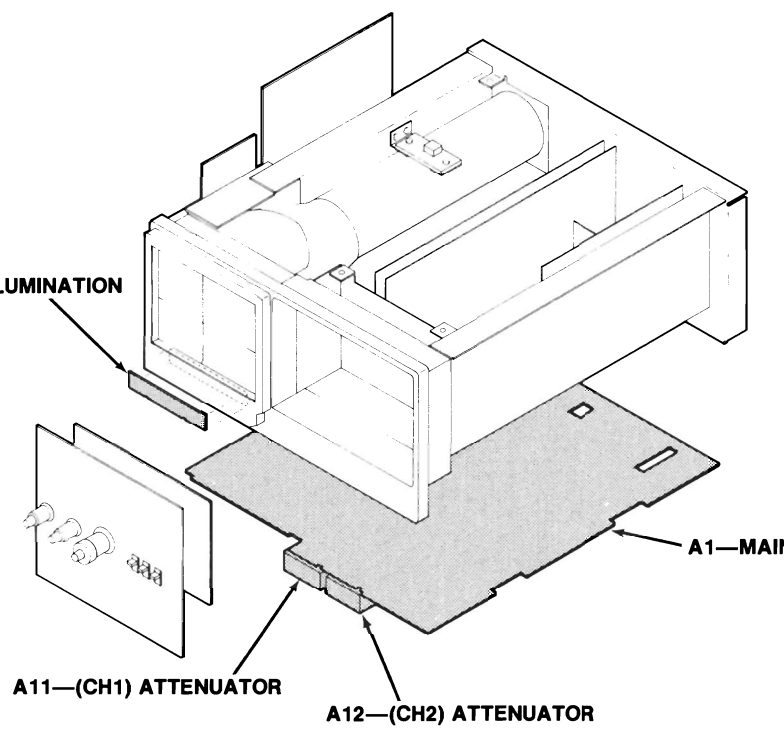

⊗ Static Sensitive Devices
 See Maintenance Section

COMPONENT NUMBER EXAMPLE

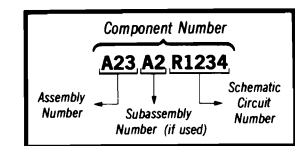

Chassis-mounted components have no Assembly Number prefix—see end of Replaceable Electrical Parts List.

Figure 10-7. A1—Main board and A8—Scale Illumination boards.

A1—MAIN BOARD (CONT)

CIRCUIT NUMBER	SCHEM NUMBER	CIRCUIT NUMBER	SCHEM NUMBER	CIRCUIT NUMBER	SCHEM NUMBER	CIRCUIT NUMBER	SCHEM NUMBER
R855	6	R983	6	U350	5	U950	11
R856	6	R984	6	U350	11	U975	5
R858	6	R985	5	U400	6	U975	6
R860	6	R995	6	U400	11	U975	11
R901	5	S615	6	U450	4	U980	5
R903	6	U100	4	U450	11	U980	6
R904	5	U100	11	U475	6	U980	11
R907	5	U110	4	U485	6	VR112	5
R910	5	U110	11	U500	5	VR125	11
R912	5	U120	4	U500	11	VR152	5
R924	5	U120	11	U550	5	VR225	11
R936	5	U130	4	U600	6	VR550	5
R937	5	U130	11	U600	11	W101	11
R939	5	U140	4	U650	5	W102	11
R940	5	U140	11	U650	11	W103	11
R941	5	U150	4	U700	5	W104	11
R942	5	U150	11	U700	11	W105	11
R943	5	U160	4	U735	6	W106	6
R944	5	U160	11	U800	6	W107	5
R945	5	U165	4	U800	11	W108	5
R947	5	U165	5	U850	5	W109	11
R950	5	U165	11	U850	11	W112	5
R951	11	U170	4	U860	5	W120**	5
R952	5	U170	11	U860	6	W121	11
R956	6	U180	4	U860	11	W122	5
R957	6	U180	11	U900	5	W12	11
R972	6	U200	4	U900	11	W141	6
R973	6	U200	11	U910	5	W918	6
R981	5	U300	4	U910	11	W919	6
R982	5	U300	11	U950	6		

A8—SCALE ILLUMINATION BOARD

CIRCUIT NUMBER	SCHEM NUMBER	CIRCUIT NUMBER	SCHEM NUMBER	CIRCUIT NUMBER	SCHEM NUMBER	CIRCUIT NUMBER	SCHEM NUMBER
DS100	4	DS101	4	DS102	4	W181	4

ATTENUATORS AND PREAMPS DIAGRAM 4

ASSEMBLY A1											
CIRCUIT NUMBER	SCHEM LOCATION	BOARD LOCATION	CIRCUIT NUMBER	SCHEM LOCATION	BOARD LOCATION	CIRCUIT NUMBER	SCHEM LOCATION	BOARD LOCATION	CIRCUIT NUMBER	SCHEM LOCATION	BOARD LOCATION
C100	1H	5C	CR150	6F	7B	R123	3B	2J	R430	7N	4E
C103	4F	6C	CR151	6F	7B	R129	5B	7B	R450	3N	4F
C105	1H	5C	CR152	6E	7B	R130	6C	8B	R451	3N	4F
C110	2H	6B	CR153	6E	7B	R131	5C	9B	R452	3N	4E
C115	2M	7E	CR154	4G	8C	R133	4M	8B	R453	3N	4F
C116	2N	8F	CR155	5G	8C	R135	4N	8A	R454	6N	4F
C117	3L	7E	CR161	5K	2D	R136	4C	2J	R455	6N	4F
C118	2N	8F	CR162	2K	2D	R140	6C	8C	R456	6N	4F
C130	5B	6C	CR163	2K	2D	R141	5C	8C	R457	6N	4F
C175	6J	2D	CR180	3K	7D	R142	5C	9C	R458	3P	4F
C176	6J	2D	CR181	7K	5D	R143	6C	8C	R459	7P	5G
C177	2J	3D	CR200	7H	4C	R144	5C	8B	R460	8M	4E
C179	2J	3D	CR201	7H	4C	R149	4D	9B	R461	8M	4E
C182	6J	3E	CR460	7N	3F	R159	6K	2D	R462	8M	4E
C183	3J	3E	CR461	7N	3E	R161	6K	2D	R463	7M	3F
C184	8L	2F				R162	2K	3D	R464	7P	3E
C185	8L	3B	J10	2H	6B	R163	2K	3D	R465	7N	4F
C200	7H	4C	J11	7H	3A	R180	3K	2E	R468	6P	4G
C202	5F	4C	J100	7P	5G	R181	3K	2E	R469	7N	3E
C203	7L	5C	J101	6F	3J	R182	7K	2E	R473	7P	5G
C205	7H	4C	J105	7P	2E	R183	7K	2E	R502	3C	1H
C211	8H	3A	J117	2M	7E	R190	3H	1H	U100	1L	6D
C217	8L	3D	J120	4M	9A	R191	3H	1H	U110	4E	7B
C223	3D	2J	J181	4N	8B	R192	3H	1J	U120	5E	7C
C301	10A	1A	J511	10P	1D	R193	3H	1E	U130A	4F	7C
C302	9A	3B	J511	2A	1D	R194	3H	1J	U130B	5F	7C
C310	8H	1B	J511	8A	1D	R195	8L	3E	U130C	5K	7C
C311	2H	1C	J512	3A	1J	R196	8L	3E	U130D	4M	7C
C329	9J	2D				R197	8L	3F	U130E	5M	7C
C332	9J	2D	L115	2N	7E	R198	8K	3F	U130F	4M	7C
C460	7N	4E				R199	8L	3F	U130G	5B	7C
C464	7P	3E	LR180	3M	5E	R200	7H	4C	U140	4D	8B
C466	8N	3E	LR280	6M	4E	R201	7H	3B	U150	5D	8C
						R202	8H	3B	U160A	2K	2D
CR100	1K	5C	Q130	6C	8B	R216	7L	3D	U160B	5K	2D
CR101	1K	5C	Q131	5C	8B	R217	7K	3D	U160C	6K	2D
CR130	5C	8B	Q190	8L	3F	R218	8K	3E	U160D	2K	2D
CR131	6C	8B	Q460A	7N	4E	R230	3D	3E	U165A	8L	2F
CR140	4G	7B	Q460B	7M	3E	R231	3C	3E	U170	3H	2E
CR141	4F	7B				R232	3B	3E	U180A	3K	2E
CR142	4F	7B	R100	1H	6C	R301	10A	1A	U180B	6K	2E
CR143	4F	7B	R101	2H	7B	R302	9A	3A	U200	5L	4D
CR144	4F	7B	R102	2H	7B	R303	10C	2A	U300	9L	2B
CR145	4E	7B	R114	2M	7D	R304	10A	1A	U450A	6N	4F
CR146	4E	7B	R115	2M	7D	R311	9A	3A	U450B	3N	4F
CR147	5G	7B	R117	3K	7E	R312	9B	2A			
CR148	5F	7B	R118	3K	6E	R329	9H	2D			
CR149	5F	7B	R121	3L	5D	R332	9H	2D			
<i>Partial A1 also shown on diagrams 5, 6, 8 and 11.</i>											
ASSEMBLY A8											
DS100	4P	1M	DS102	5P	1P	W181	5P	1P			
DS101	5P	1N									
OTHER PARTS											
J1	1A	CHASSIS	P10	2G	CHASSIS	R134	4L	CHASSIS	W10	2G	CHASSIS
J2	7A	CHASSIS	P11	7G	CHASSIS	R301	10A	CHASSIS	W11	7G	CHASSIS
J3	9A	CHASSIS	P105	7P	CHASSIS	R302	9A	CHASSIS			
J4	10A	CHASSIS	P120	4M	CHASSIS	R304	10A	CHASSIS			
J5	7P	CHASSIS	P120	4M	CHASSIS	R311	9A	CHASSIS			
			P181	4N	CHASSIS						

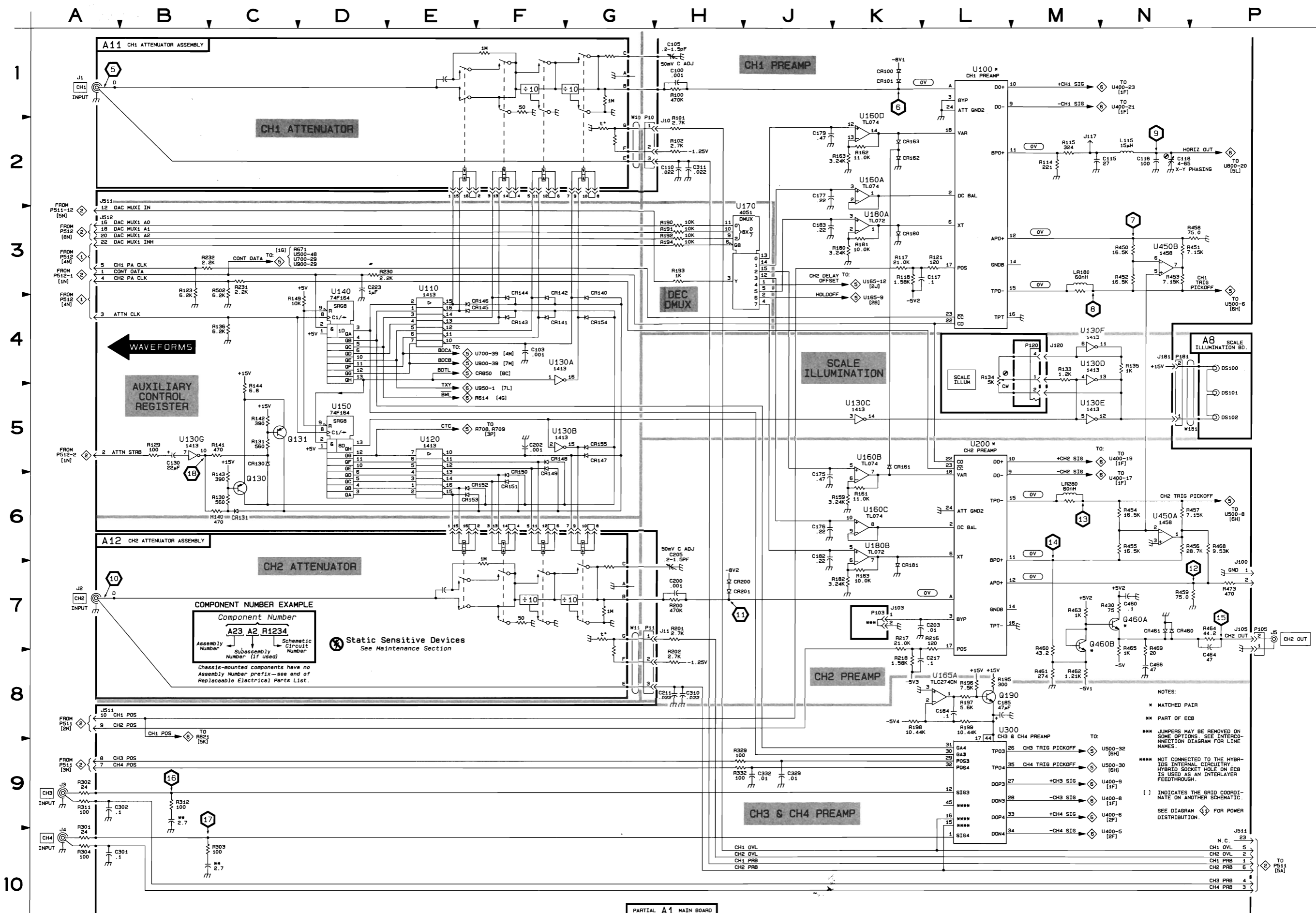

2445A/2455A

PARTIAL A1 MAIN BOARD

6017-04

ATTENUATORS AND PREAMPS 4

10

9

8

7

6

5

4

3

2

1

A

B

C

D

E

F

G

H

J

K

L

M

N

P

DISPLAY SEQUENCER, TRIGGERING, A & B SWEEPS DIAGRAM 5

ASSEMBLY A1											
CIRCUIT NUMBER	SCHEM LOCATION	BOARD LOCATION	CIRCUIT NUMBER	SCHEM LOCATION	BOARD LOCATION	CIRCUIT NUMBER	SCHEM LOCATION	BOARD LOCATION	CIRCUIT NUMBER	SCHEM LOCATION	BOARD LOCATION
C109	1R	2L	E940	6P	7L	R543	7K	3F	R924	7M	8H
C152	2E	2F	E980	4P	7L	R544	7F	3K	R936	6M	10G
C154	3D	2F				R545	7F	4J	R937	5M	10G
C180	3C	2E	J9	8S	2A	R550	8R	1G	R939	6R	7L
C181	2K	2F	J101	6F	3J	R551	8P	1F	R940	7P	7L
C351	48	5G	J102	3J	8G	R552	8P	1F	R941	6P	10K
C512	5J	4H	J102	4M	8G	R553	8P	1F	R942	7P	10L
C513	8H	4J	J102	7M	8G	R554	8P	1G	R943	6N	10J
C520	7F	3J	J104	4S	6L	R555	7R	1G	R944	6N	10K
C528	7H	2H	J104	6S	6L	R556	8R	1F	R945	6P	9K
C536	5J	1G	J109	4K	4H	R557	8R	1E	R947	6R	7L
C537	8H	2F	J119	9S	4J	R558	9R	1E	R950	6R	7L
C544	7F	4J	J120	4B	9A	R560	7P	1G	R952	7H	8L
C645	6J	6H	J191	5A	10L	R643	7J	6H	R981	4R	5L
C650	7H	8L	J411	5S	1L	R644	6H	6H	R982	4R	6L
C653	6F	4K	J411	6A	1L	R645	6H	7H	R985	5K	2L
C660	3E	3E	J411	9S	1L	R646	7H	6H			
C669	4F	3K	J511	8A	1D	R651	6B	1K	U165B	8P	2F
C707	3N	9C	J512	10A	1J	R652	6F	3K	U165C	2C	2F
C708	2P	9C	J512	1A	1J	R653	5H	5L	U165D	2K	2F
C709	2P	10C	J512	1S	1J	R655	6F	1K	U350A	88	10B
C712	1M	10E	J512	5A	1J	R669	5F	3K	U350B	8E	10B
C742	2M	8D				R670	5C	2J	U500	4J	3G
C830	98	1L	Q154	3D	2F	R671	2G	2J	U550A	8R	1F
C848	8B	9E	Q155	3E	2F	R678	5C	2J	U550B	8R	1F
C849	10B	10G	Q550	8R	2F	R707	3P	10C	U550C	8P	1F
C851	3K	10F	Q645	6H	7G	R708	3R	9B	U550D	8P	1F
C852	3K	10E	Q709	2P	10D	R709	2P	10B	U550E	9P	1F
C853	3K	10F	Q710	2N	10E	R710	1M	10F	U650	2G	4K
C854	3K	10E	Q741	4P	8D	R713	2M	10E	U700	2N	9D
C907	5N	9K				R723	3L	10E	U850A	8D	9F
C908	6N	10K	R112	1A	7L	R724	3M	10E	U850B	6M	9F
C912	5M	10G	R152	2D	2F	R736	2M	10G	U850C	3L	9F
C941	7P	7L	R153	2D	2F	R737	2M	10F	U860A	3R	7G
C947	6R	7L	R154	3D	2F	R738	2L	10G	U860B	2L	7G
C982	4R	6L	R155	2E	2F	R741	4N	7D	U900	5N	10H
			R156	3D	2E	R742	4N	8D	U910A	5M	10F
CR354	6D	3J	R165	2K	3F	R743	4K	7D	U910B	2M	10F
CR360	5D	4J	R353	6F	3J	R744	4M	8F	U975B	4R	7L
CR503	4H	3J	R361	5E	3J	R745	3N	8D	U975D	6R	7L
CR538	8E	9B	R503	4H	2J	R746	4R	6L	U980A	4P	7L
CR539	8E	10B	R504	4H	2J	R750	3N	8D	U980D	6P	7L
CR652	5H	5L	R511	4H	3J	R751	3P	8K			
CR653	6F	3K	R512	4H	3J	R752	3R	7F	VR112	1P	2L
CR707	3P	10B	R513	8H	4J	R753	3R	9K	VR152	2D	2F
CR741	4N	7D	R518	4K	3J	R754	3R	8K	VR550	7P	1F
CR746	4R	6L	R519	4K	3J	R849	9C	9E			
CR747	4R	6L	R520	7F	3J	R852	3K	10F	W107	6S	7M
CR752	3R	8K	R521	7F	3J	R853	3K	10F	W108	4S	6M
CR753	4P	8J	R527	7H	1H	R901	7M	10F	W112	1A	7M
CR850	9C	10F	R529	7H	1H	R904	6M	10K	W120**	1R	1H
CR950	6R	8L	R537	8H	1E	R907	5N	9J	W122	7A	5J
CR951	6R	7L	R538	8E	9B	R910	5M	10F			
CR982	4R	6L	R542	7K	3F	R912	5M	10F			

Partial A1 also shown on diagrams 4, 6, 8 and 11.

OTHER PARTS											
J7	6S	CHASSIS	P107	6S	CHASSIS	P122	7A	CHASSIS	R351	4B	CHASSIS
J8	4S	CHASSIS	P10B	4S	CHASSIS	R112	1A	CHASSIS	R352	4B	CHASSIS
J12	1A	CHASSIS	P120	4B	CHASSIS						

DISPLAY SEQUENCER, TRIGGERING, A & B SWEEP



A B C D E F G H J K L M N P R S

1
2
3
4
5
6
7
8
9
10

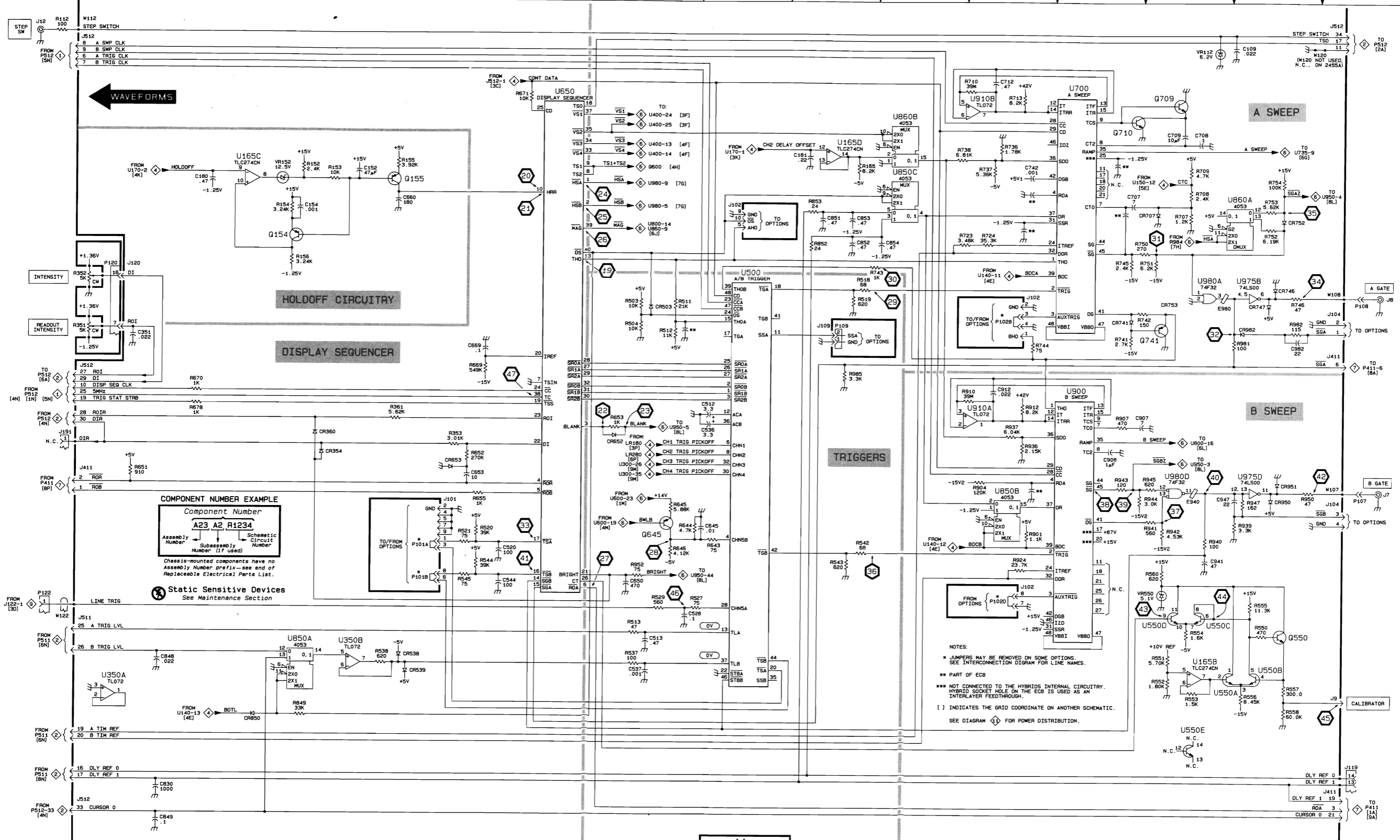

2445A/2455A

PARTIAL A1 MAIN BOARD

6017-05

HOLDOFF CIRCUITRY, DISPLAY SEQUENCER, TRIGGERING, A & B SWEEPS

DISPLAY SEQUENCER, TRIGGERING, A & B SWEEP 5

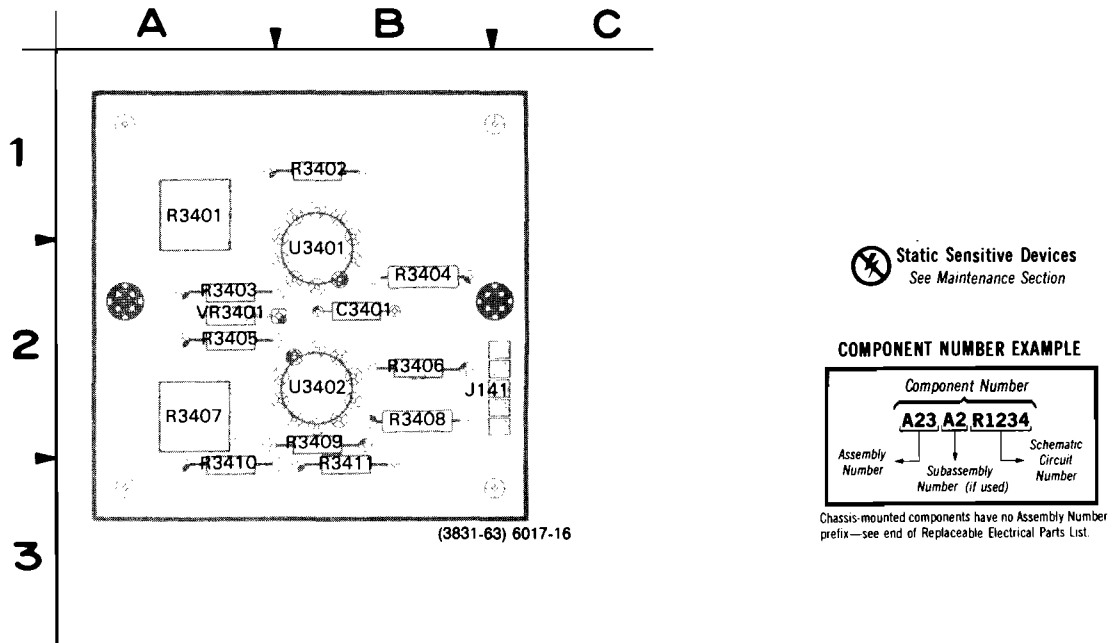
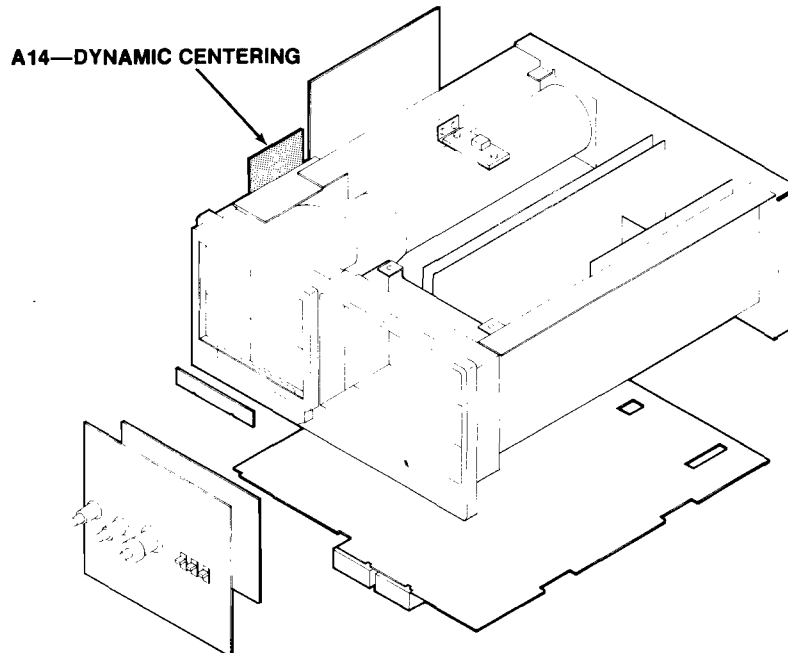

Figure 10-8. A14—Dynamic Centering board.

A14—DYNAMIC CENTERING BOARD

CIRCUIT NUMBER	SCHEM NUMBER	CIRCUIT NUMBER	SCHEM NUMBER	CIRCUIT NUMBER	SCHEM NUMBER	CIRCUIT NUMBER	SCHEM NUMBER	CIRCUIT NUMBER	SCHEM NUMBER	CIRCUIT NUMBER	SCHEM NUMBER
C3401	6	R3403	6	R3408	6	U3402	6				
J141	6	R3404	6	R3409	6	VR3401	6				
J141	6	R3405	6	R3410	6						
R3401	6	R3406	6	R3411	6						
R3402	6	R3407	6	U3401	6						



2445A CHANNEL SWITCH AND OUTPUT AMPLIFIERS DIAGRAM 6

ASSEMBLY A1											
CIRCUIT NUMBER	SCHEM LOCATION	BOARD LOCATION	CIRCUIT NUMBER	SCHEM LOCATION	BOARD LOCATION	CIRCUIT NUMBER	SCHEM LOCATION	BOARD LOCATION	CIRCUIT NUMBER	SCHEM LOCATION	BOARD LOCATION
C402	3F	6G	J511	4A	1D	R491	1E	3K	R822	5B	8E
C403	2J	6J	J511	5A	1D	R492	2E	4L	R823	5K	9E
C404	2H	5J	J512	10N	1J	R493	2E	3L	R850	6J	10G
C412	2F	5G	J512	4N	1J	R494	2D	3L	R855	6K	8F
C478	3E	4L	J512	9A	1J	R495	2F	4K	R856	6L	10E
C487	2C	4L	J512	9N	1J	R496	1D	3L	R858	6K	10E
C488	2C	3L				R497	4D	6L	R860	6K	10D
C601	2K	5J	L605	2L	6J	R498	3D	5K	R903	7H	7K
C617	4L	6H	L606	2K	6K	R500	9B	1K	R956	9K	8L
C625	1M	7G	L607	2K	6H	R501	10B	1K	R957	8L	8K
C735	6H	8E	L608	2L	6H	R600	4M	7K	R972	9N	10L
C803	6L	9G	L609	2K	6J	R601	2K	5J	R973	9M	10L
C804	6M	9G	L610	2K	6H	R602	2L	5J	R983	7G	7L
C805	7M	9G	L619	4M	7G	R605	2L	5J	R984	7G	7L
C806	5M	9F	L628	3M	8J	R606	2K	6J	R995	9B	8L
C808	5M	9G	L633	2M	8J	R607	2K	6H			
C809	5M	9G	L644	3M	7K	R610	2K	5H	S615	4K	10B
C817	5C	8F				R614	4H	8F			
C822	5B	9E	Q600	4J	5K	R615	4K	10B	U400	1F	5F
C823	5K	7E	Q623	1M	7H	R617	4L	6H	U475A	3D	4K
C957	9K	8L	Q624	1L	8H	R618	4L	6H	U475B	3D	4K
C972	9N	10L				R619	4M	7H	U475C	1D	4K
C995	9B	8L	R401	3F	6G	R620	4N	8H	U475D	3E	4K
			R402	3F	6G	R622	4L	7H	U485A	2D	4L
CR476	3E	4K	R403	2H	5J	R623	1L	7H	U485B	2D	4L
CR484	3D	4L	R404	3J	6J	R624	1M	7G	U485C	2C	4L
CR485	3C	4L	R405	2J	6J	R637	3L	8K	U485D	2C	4L
CR495	2E	3L	R410	2J	6J	R638	3L	7K	U600	1L	7J
CR600	4J	7K	R412	2F	5G	R639	3J	7K	U735A	5J	9E
CR601	3M	8K	R416	2F	4F	R642	4J	5K	U735B	6H	9E
CR616	4G	7L				R650	4J	5K	U735C	6H	9E
CR619	4M	7G	R470	4C	4L	R659	3K	7K	U735D	6H	9E
CR620	3N	8H	R471	3D	4L	R731	5H	8E	U735E	6H	9E
CR621	3N	8H	R476	3F	4K	R732	6H	9E	U800	4M	9F
CR956	9L	8L	R477	3E	3K	R733	6J	9F	U860C	6K	7G
CR966	8M	10L	R478	3E	4K	R734	6J	9F	U950	7M	9L
CR972	9M	10L	R479	2E	5K	R735	6H	8F	U975A	4D	7L
CR995	9B	8L	R480	2D	3K	R800	7L	9G	U975C	7G	7L
			R481	3D	4L	R801	7K	9G	U980B	8G	7L
			R482	3D	4L	R802	5L	9G	U980C	7G	7L
DL100	1G	6F	R483	2D	5L	R803	5L	9G			
			R484	3D	4L	R804	6M	9G	W106	9A	8M
J191	8K	10L	R485	4C	4L	R805	6M	9G	W141	7C	10G
J191	8N	10L	R486	2C	4L	R806	7M	9G	W141	7F	10G
J191	9A	10L	R486	2C	4L	R809	6M	8G	W918	6N	8G
J411	10A	1L	R487	2C	4L	R817	5C	8F	W919	6N	9G
J411	2A	1L	R488	2C	4L	R820	5K	7F			
J411	4A	1L	R489	2B	3L	R821	5K	7E			
J411	9N	1L	R490	1C	4K						

Partial A1 also shown on diagrams 4, 5, 8 and 11.

ASSEMBLY A9											
P191	8K	4B	R1833	8J	1C	R1842	8J	1C			
			R1834	8J	1B						

Partial A9 also shown on diagrams 8 and 12.

ASSEMBLY A14											
C3401	7C	2B	R3402	8D	1B	R3408	6E	2B	U3402	5E	2B
			R3403	5D	2A	R3409	6D	2B			
J141	5E	2C	R3404	8E	2B	R3410	6C	2A			
J141	7C	2C	R3405	6C	2A	R3411	6C	2B	VR3401	5C	2A
			R3406	6C	2B						
R3401	7E	1A	R3407	6E	2A	U3401	7E	1B			

OTHER PARTS											
J6	9A	CHASSIS	P106	9A	CHASSIS	P141	7C	CHASSIS	W916	2N	CHASSIS
			P141	5F	CHASSIS				W917	3N	CHASSIS

2445A CHANNEL SWITCH

A B C D E F G H J K L M N

1
2
3
4
5
6
7
8
9
10

VERTICAL CHANNEL SWITCH

WAVEFORMS

COMPONENT NUMBER EXAMPLE

Component Number
A23 A2 R1234

Assembly Number Subassembly Number (if used) Schematic Circuit Number

Chassis-mounted components have no Assembly Number prefix—see end of Replaceable Electrical Parts List.

Static Sensitive Devices
See Maintenance Section

NOTES:

() INDICATES THE GRID COORDINATE ON ANOTHER SCHEMATIC.
SEE DIAGRAM FOR POWER DISTRIBUTION.

** PART OF ECB

VERTICAL AMPLIFIER

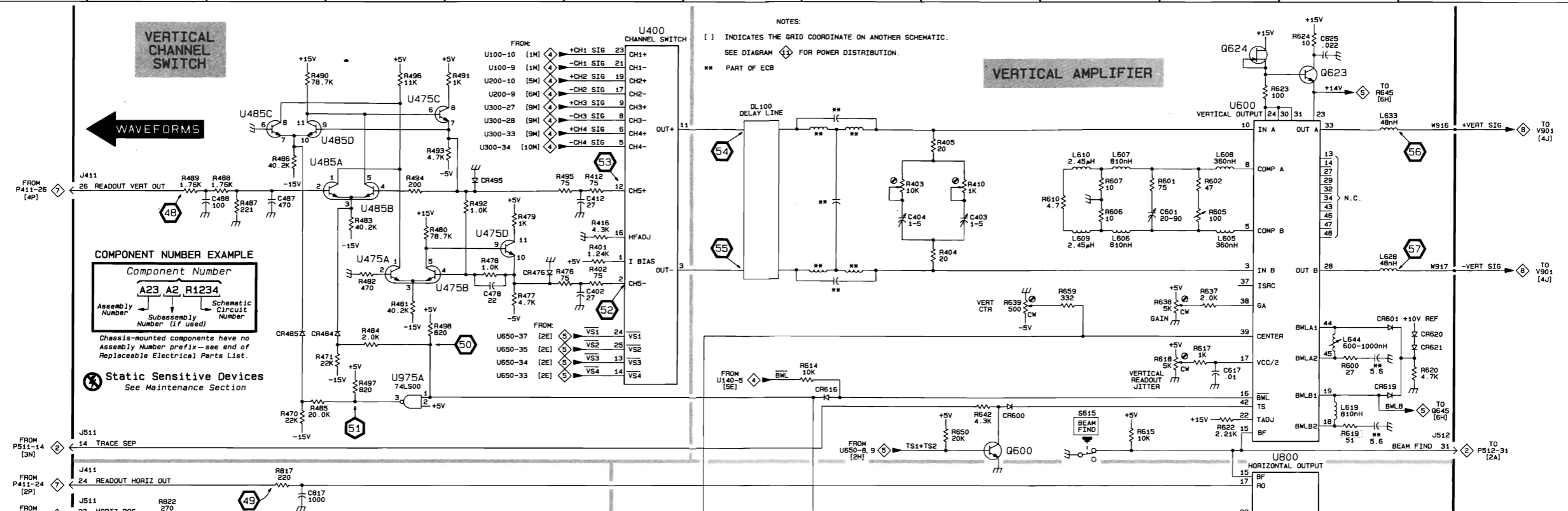

DYNAMIC CENTERING

HORIZONTAL AMPLIFIER

Z-AXIS AMPLIFIER

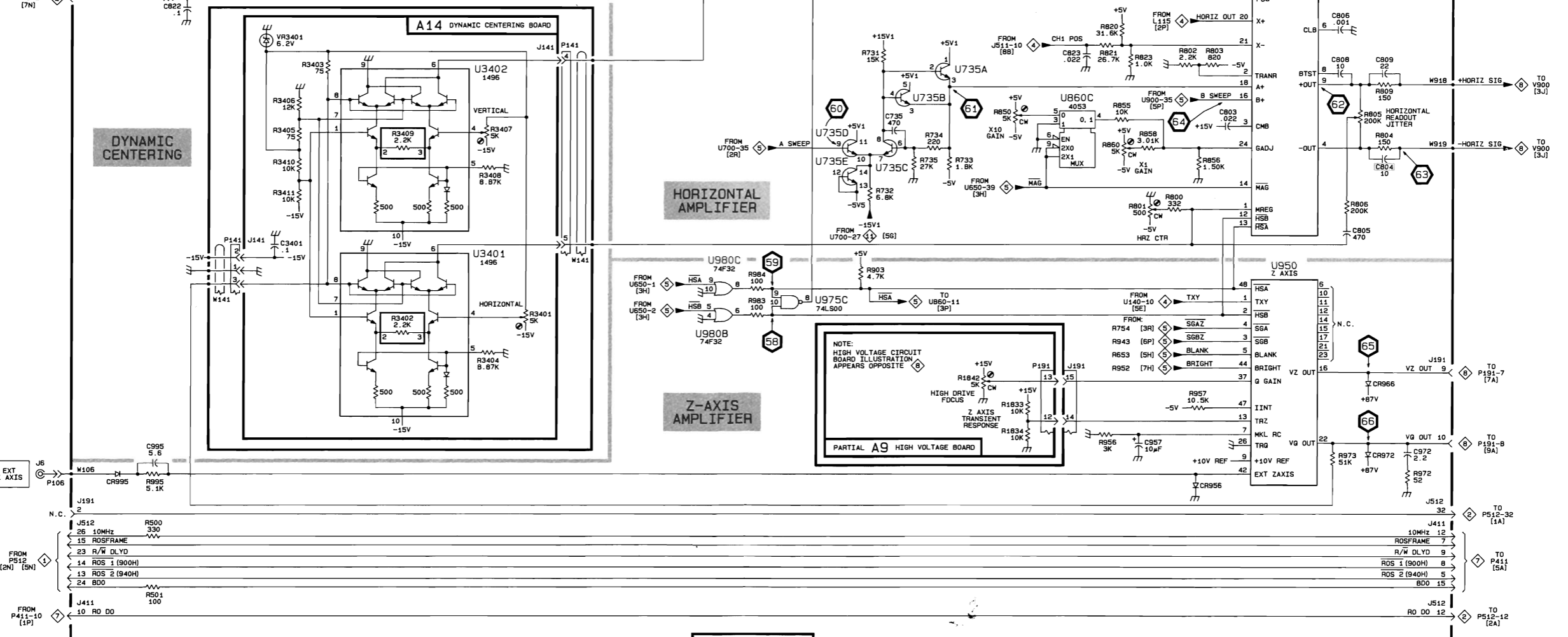

2455A CHANNEL SWITCH AND OUTPUT AMPLIFIERS DIAGRAM 6

ASSEMBLY A1											
CIRCUIT NUMBER	SCHEM LOCATION	BOARD LOCATION	CIRCUIT NUMBER	SCHEM LOCATION	BOARD LOCATION	CIRCUIT NUMBER	SCHEM LOCATION	BOARD LOCATION	CIRCUIT NUMBER	SCHEM LOCATION	BOARD LOCATION
C402	3F	6G	J511	4A	1D	R491	1E	3K	R822	5B	8E
C403	2J	6J	J511	5A	1D	R492	2E	4L	R823	5K	9E
C404	2H	5J	J512	10N	1J	R493	2E	3L	R850	6J	10G
C412	2F	5G	J512	4N	1J	R494	2D	3L	R855	6K	8F
C478	3E	4L	J512	9A	1J	R495	2F	4K	R856	6L	10E
C487	2C	4L	J512	9N	1J	R496	1D	3L	R858	6K	10E
C488	2C	3L				R497	4D	6L	R860	6K	10D
C601	2K	5J	L605	2L	6J	R498	3D	5K	R903	7H	7K
C617	4L	6H	L606	2K	6K	R500	9B	1K	R956	9K	8L
C625	1M	7G	L607	2K	6H	R501	10B	1K	R957	8L	8K
C735	6H	8E	L608	2L	6H	R600	4M	7K	R972	9N	10L
C803	6L	9G	L609	2K	6J	R601	2K	5J	R973	9M	10L
C804	6M	9G	L610	2K	6H	R602	2L	5J	R983	7G	7L
C805	7M	9G	L619	4M	7G	R605	2L	5J	R984	7G	7L
C806	5M	9F	L628	3M	8J	R606	2K	6J	R995	98	8L
C808	5M	9G	L633	2M	8J	R607	2K	6H			
C809	5M	8G	L644	3M	7K	R610	2K	5H	S615	4K	10B
C817	5C	8F				R614	4H	8F			
C822	5B	9E	Q600	4J	5K	R615	4K	10B	U400	1F	5F
C823	5K	7E	Q623	1M	7H	R617	4L	6H	U475A	3D	4K
C957	9K	8L	Q624	1L	8H	R618	4L	6H	U475B	3D	4K
C972	9N	10L				R619	4M	7H	U475C	1D	4K
C995	98	8L				R620	4N	8H	U475D	3E	4K
CR476	3E	4K	R401	3F	6G	R622	4L	7H	U485A	2D	4L
CR484	3D	4L	R402	3F	6G	R623	1L	7H	U485B	2D	4L
CR485	3C	4L	R403	2H	5J	R624	1M	7G	U485C	2C	4L
CR495	2E	3L	R404	3J	6J	R637	3L	8K	U485D	2C	4L
CR600	4J	7K	R405	2J	6J	R638	3L	7K	U600	1L	7J
CR601	3M	8K	R410	2J	6J	R639	3J	7K	U735A	5J	9E
CR616	4G	7L	R412	2F	5G	R642	4J	5K	U735B	6H	9E
CR619	4M	7G	R416	2F	4F	R650	4J	5K	U735C	6H	9E
CR620	3N	8H	R417*	2F	4G	R659	3K	7K	U735D	6H	9E
CR621	3N	8H	R470	4C	4L	R731	5H	8E	U735E	6H	9E
CR956	9L	8L	R471	3D	4L	R732	6H	9E	U800	4M	9F
CR966	8M	10L	R476	3F	4K	R733	6J	9F	U860C	6K	7G
CR972	9M	10L	R477	3E	3K	R734	6J	9F	U950	7M	9L
CR995	9B	8L	R478	3E	4K	R735	6H	8F	U975A	4D	7L
DL100	1G	6F	R479	2E	5K	R800	7L	9G	U975C	7G	7L
J191	8K	10L	R480	2D	3K	R801	7K	9G	U980B	8G	7L
J191	8N	10L	R481	3D	4L	R802	5L	9G	U980C	7G	7L
J191	9A	10L	R482	3D	4L	R803	5L	9G			
J411	10A	1L	R483	2D	5L	R804	6M	9G	W106	9A	8M
J411	2A	1L	R484	3D	4L	R805	6M	9G	W141	7C	10G
J411	4A	1L	R485	4C	4L	R806	7M	9G	W141	7F	10G
J411	9N	1L	R486	2C	4L	R809	6M	8G	W918	6N	8G
			R487	2C	4L	R817	5C	8F	W919	6N	9G
			R488	2C	4L	R820	5K	7F			
			R489	2B	3L	R821	5K	7E			
			R490	1C	4K						

Partial A1 also shown on diagrams 4, 5, 8 and 11.

ASSEMBLY A9											
P191	8K	4B	R1833	8J	1C	R1842	8J	1C			
			R1834	8J	1B						

Partial A9 also shown on diagrams 8 and 12.

ASSEMBLY A14											
C3401	7C	2B	R3402	8D	1B	R3408	6E	2B	U3402	5E	2B
J141	5E	2C	R3403	5D	2A	R3409	6D	2B			
J141	7C	2C	R3404	8E	2B	R3410	6C	2A			
			R3405	6C	2A	R3411	6C	2B	VR3401	5C	2A
R3401	7E	1A	R3406	6C	2B						
			R3407	6E	2A	U3401	7E	1B			

OTHER PARTS											
J6	9A	CHASSIS	P106	9A	CHASSIS	P141	7C	CHASSIS	W916	2N	CHASSIS
			P141	5F	CHASSIS				W917	3N	CHASSIS



A B C D E F G H J K L M N

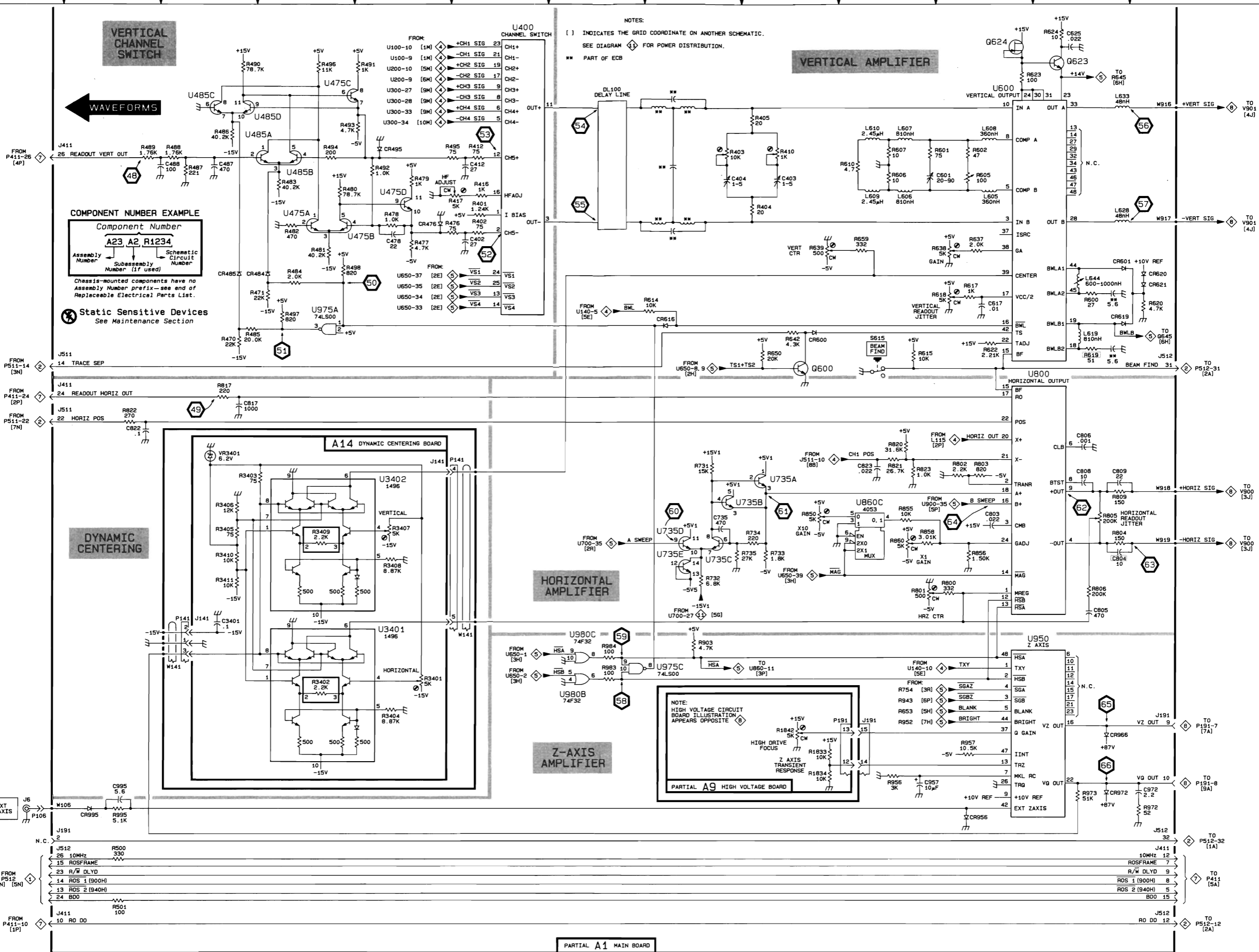

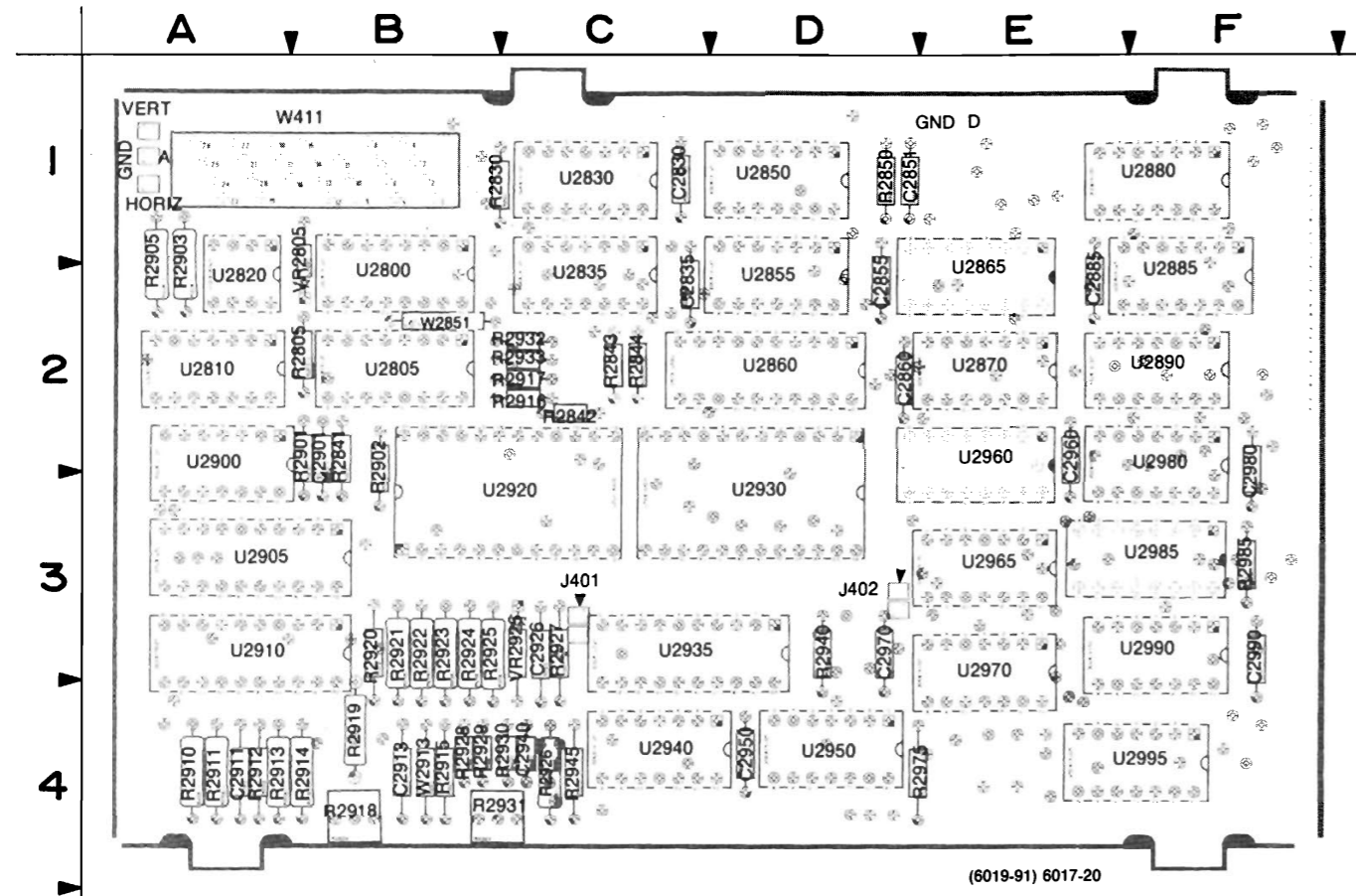

(6019-91) 6017-20

Figure 10-9. A4—Readout board.

A4—READOUT BOARD

CIRCUIT NUMBER	SCHEM NUMBER	CIRCUIT NUMBER	SCHEM NUMBER	CIRCUIT NUMBER	SCHEM NUMBER	CIRCUIT NUMBER	SCHEM NUMBER
C2830	12	R2911	7	U2805	12	U2920	7
C2835	12	R2912	7	U2810	7	U2920	12
C2851	12	R2913	7	U2810	12	U2930	7
C2855	12	R2914	7	U2820	7	U2930	12
C2860	12	R2915	7	U2820	12	U2935	7
C2885	12	R2916	7	U2830	7	U2935	12
C2901	12	R2917	7	U2830	12	U2940	7
C2911	7	R2918	7	U2835	7	U2940	12
C2913	12	R2919	7	U2835	12	U2950	7
C2926	12	R2920	7	U2850	7	U2950	12
C2940	12	R2921	7	U2850	12	U2960	7
C2950	12	R2922	7	U2855	7	U2960	12
C2960	12	R2923	7	U2855	12	U2965	7
C2970	12	R2924	7	U2860	7	U2965	12
C2980	12	R2925	7	U2860	12	U2970	7
C2990	12	R2926	7	U2865	7	U2970	12
J401	7	R2927	7	U2870	7	U2980	7
J402	7	R2928	7	U2870	12	U2980	12
R2805	12	R2929	7	U2880	7	U2985	7
R2830	7	R2930	7	U2880	12	U2985	12
R2841	7	R2931	7	U2885	7	U2990	7
R2842	7	R2932	7	U2885	12	U2990	12
R2843	7	R2933	7	U2890	7	U2995	7
R2844	7	R2940	7	U2890	12	U2995	12
R2850	7	R2945	7	U2900	7	VR2805	12
R2901	7	R2975	7	U2900	12	VR2925	7
R2902	7	R2985	7	U2905	7	W411	7
R2903	7	U2800	7	U2905	12	W411	12
R2905	7	U2800	12	U2910	7	W2851	7
R2910	7	U2805	7	U2910	12	W2913	12

⊗ Static Sensitive Devices
See Maintenance Section

COMPONENT NUMBER EXAMPLE

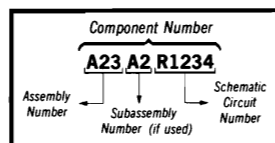

Chassis-mounted components have no Assembly Number prefix—see end of Replaceable Electrical Parts List.

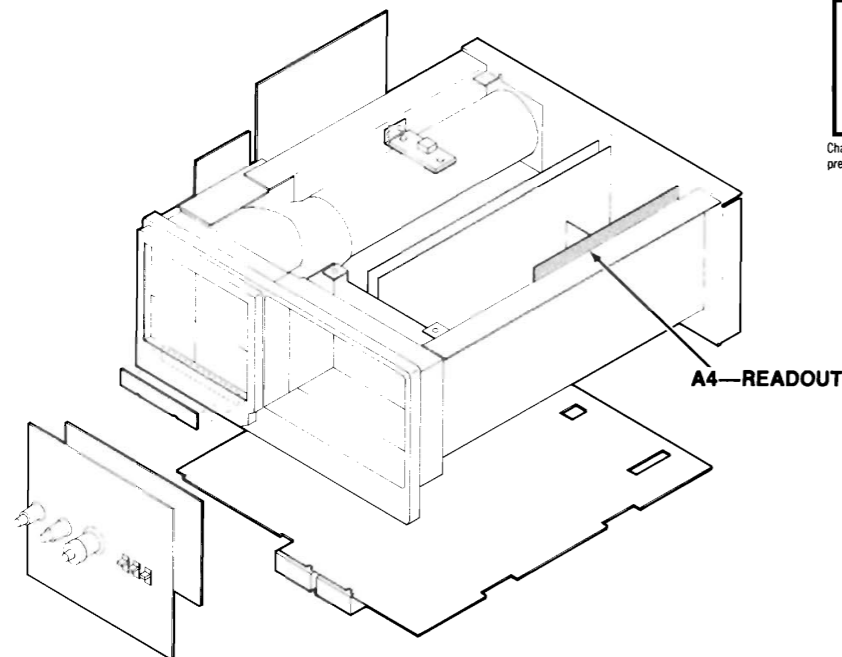

READOUT DIAGRAM 7

ASSEMBLY A4								
CIRCUIT NUMBER	SCHEM LOCATION	BOARD LOCATION	CIRCUIT NUMBER	SCHEM LOCATION	BOARD LOCATION	CIRCUIT NUMBER	SCHEM LOCATION	BOARD LOCATION
C2911	2H	4A	R2932	5D	2C	U2890D	7J	2F
J401	4G	3C	R2933	5D	2C	U2900A	2E	2A
J402	5G	3D	R2940	7D	3D	U2900B	4J	2A
			R2945	2B	4C	U2900C	5J	2A
			R2975	7L	4E	U2905	4H	3A
R2830	7B	1C	R2985	7E	3F	U2910	1J	3A
R2841	5K	2B				U2920	1F	3C
R2842	3B	2C	U2800	4M	1B	U2930	4G	3D
R2843	3B	2C	U2805	2M	2B	U2935	1D	3C
R2844	4B	2C	U2810A	5J	2A	U2940	1C	4C
R2850	7C	1D	U2810B	5J	2A	U2950A	7D	4D
R2901	4K	2B	U2810C	5M	2A	U2950B	8H	4D
R2902	2E	2B	U2810D	5M	2A	U2960	3D	2E
R2903	5N	1A	U2820A	4N	2A	U2965A	4C	3E
R2905	5N	1A	U2820B	2N	2A	U2965B	8G	3E
R2910	1H	4A	U2830	6B	1C	U2965C	4E	3E
R2911	1H	4A	U2835A	5F	2C	U2970A	7L	3E
R2912	2J	4A	U2835B	4D	2C	U2970B	7G	3E
R2913	2K	4A	U2835C	7F	2C	U2970C	6G	3E
R2914	2K	4B	U2835D	2E	2C	U2970D	7F	3E
R2915	3K	4B	U2850A	7C	1D	U2980A	8G	2F
R2916	5D	2C	U2850B	7D	1D	U2980B	7N	2F
R2917	5D	2C	U2855A	1B	1D	U2980C	7M	2F
R2918	4L	4B	U2855B	5E	1D	U2980D	5E	2F
R2919	4L	4B	U2855C	3E	1D	U2985	7E	3F
R2920	4K	3B	U2855D	3E	1D	U2990A	7D	3F
R2921	4K	3B	U2860	3F	2D	U2990B	7G	3F
R2922	4K	3B	U2865	4D	2E	U2990C	7L	3F
R2923	4K	3B	U2870	5F	2E	U2990D	7L	3F
R2924	4K	3B	U2880A	7H	1F	U2995	7K	4F
R2925	3K	3B	U2880B	7M	1F			
R2926	4K	4C	U2885A	8G	2F	VR2925	3K	3C
R2927	4G	3C	U2885B	7J	2F			
R2928	3J	4B	U2885C	7N	2F	W411	8P	1B
R2929	3J	4B	U2890A	6B	2F	W411	9A	1B
R2930	3K	4C	U2890B	8J	2F	W2B51	4L	2B
R2931	4K	4C	U2890C	6K	2F			

Partial A4 also shown on diagram 12.

OTHER PARTS								
P411	1A	CHASSIS	P411	1P	CHASSIS			

READOUT BOARD



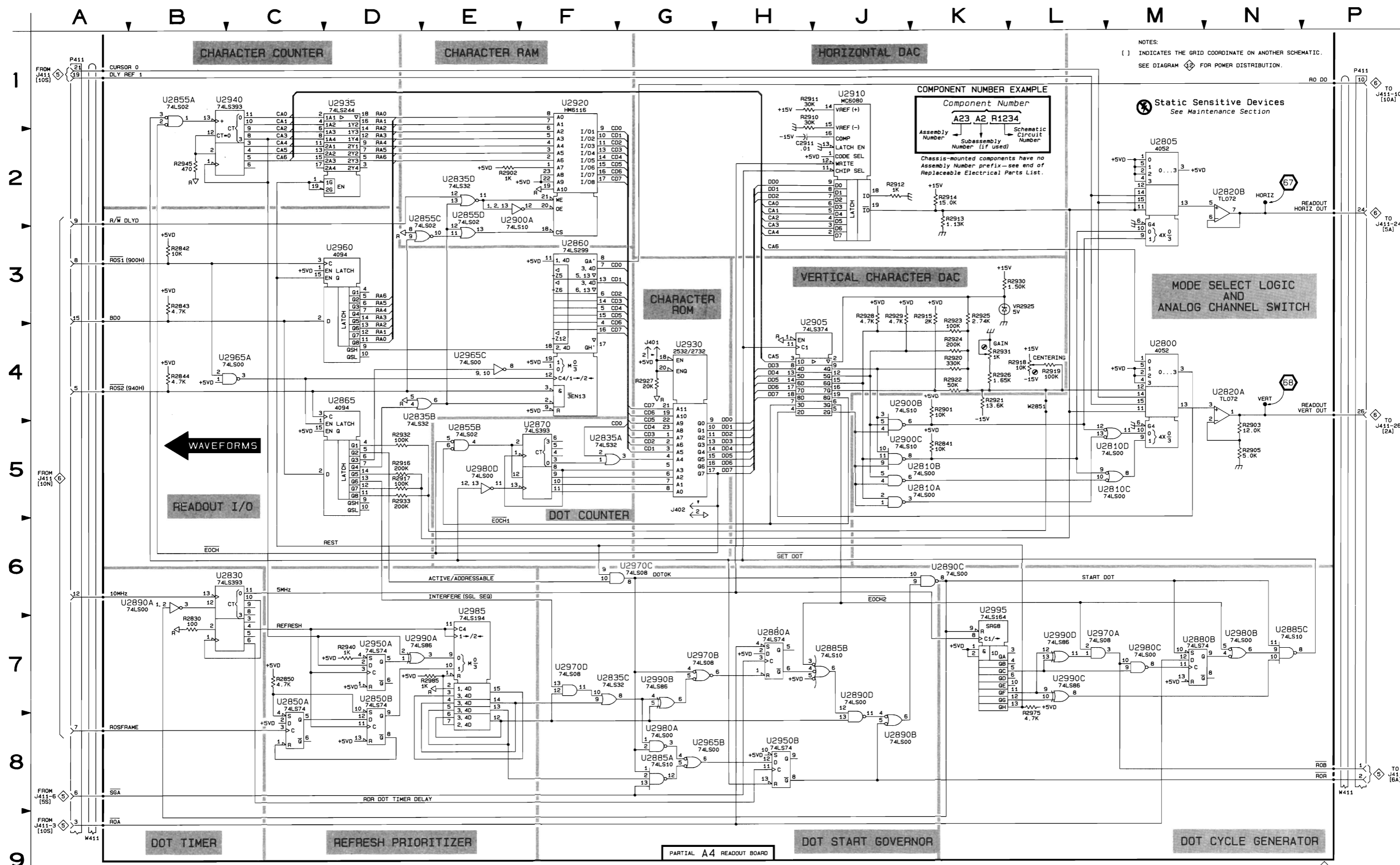

NOTES:
 () INDICATES THE GRID COORDINATE ON ANOTHER SCHEMATIC.
 SEE DIAGRAM \diamond FOR POWER DISTRIBUTION.

\otimes Static Sensitive Devices
 See Maintenance Section

COMPONENT NUMBER EXAMPLE

Component Number	A23	A2	R1234
Assembly Number			
Schematic Circuit Number			
Subassembly Number (if used)			

Chassis-mounted components have no Assembly Number prefix—see end of Replaceable Electrical Parts List.

2445A/2455A

6017-08

READOUT \diamond

READOUT BOARD

\diamond

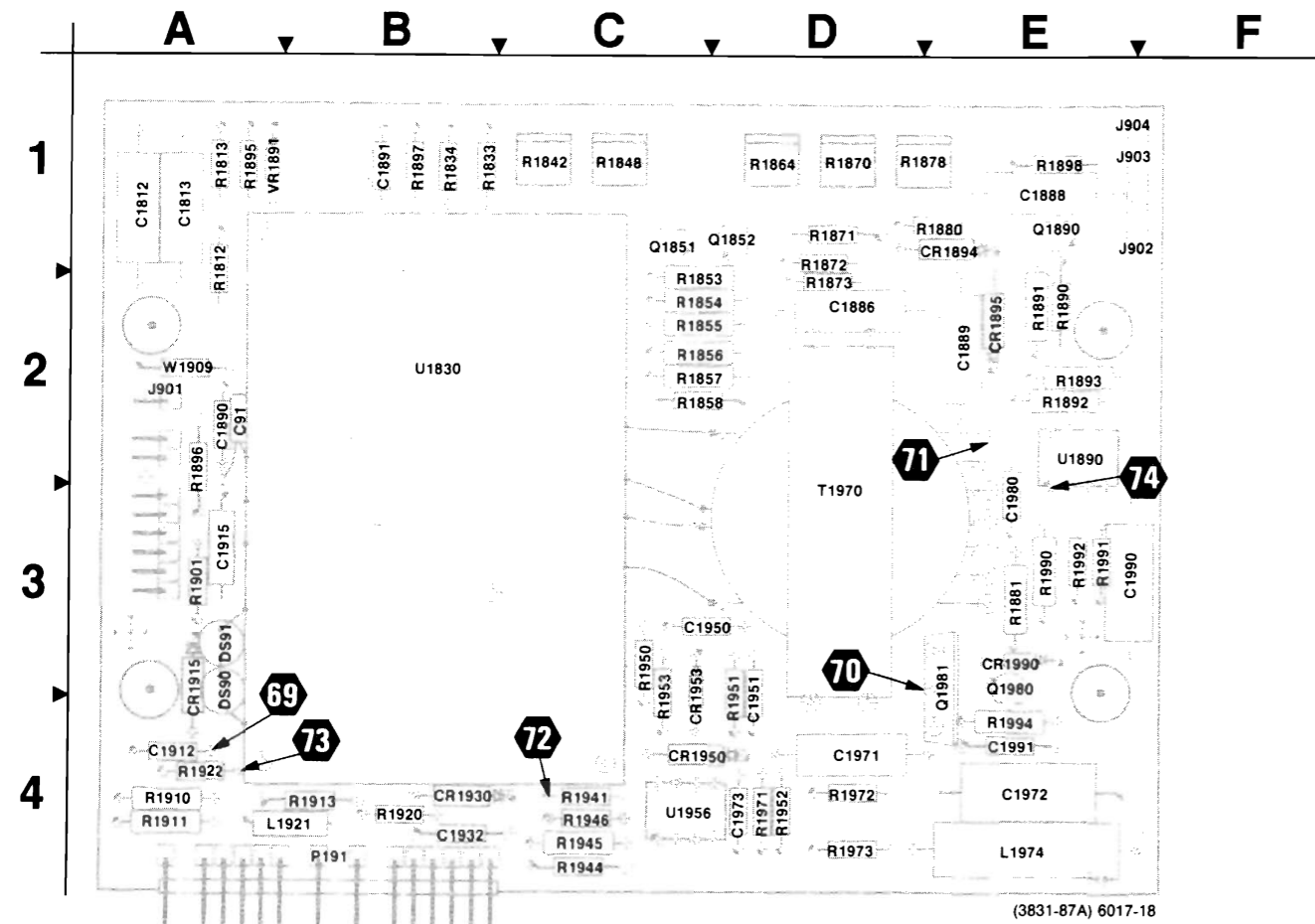
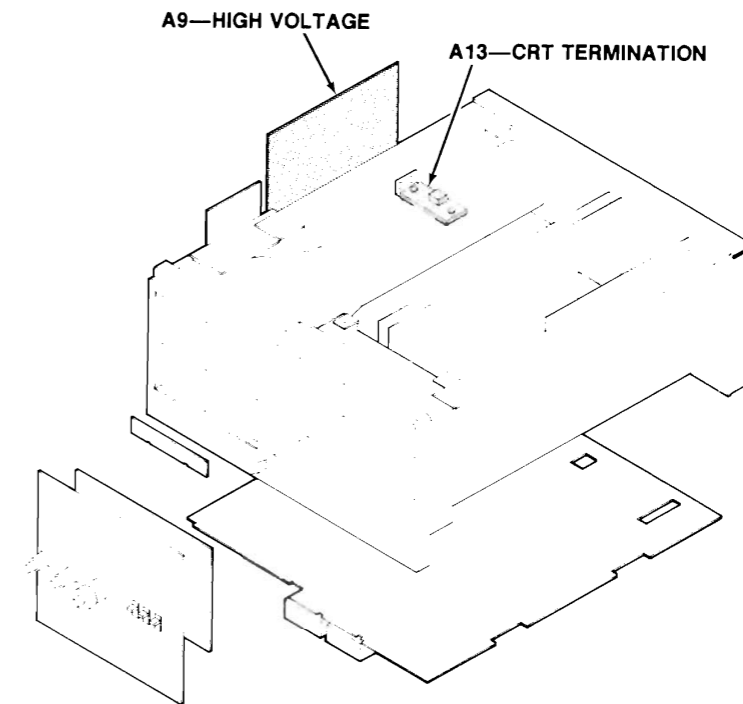

Figure 10-10. A9—High Voltage board.

A9—HIGH VOLTAGE BOARD

CIRCUIT NUMBER	SCHEM NUMBER	CIRCUIT NUMBER	SCHEM NUMBER	CIRCUIT NUMBER	SCHEM NUMBER	CIRCUIT NUMBER	SCHEM NUMBER
C91	8	CR1990	8	R1853	8	R1913	8
C1812	8	DS90	8	R1854	8	R1920	8
C1813	8	DS91	8	R1855	8	R1922	8
C1886	8	J901	8	R1856	8	R1941	8
C1888	8	J901	8	R1857	8	R1944	8
C1889	8	J901	8	R1858	8	R1945	8
C1890	8	J902	8	R1864	8	R1950	8
C1891	8	J903	8	R1870	8	R1951	8
C1912	8	J904	8	R1871	8	R1952	8
C1915	8	L1921	8	R1872	8	R1953	8
C1932	8	L1974	8	R1873	8	R1971	8
C1950	8	P191	6	R1878	8	R1972	8
C1951	8	P191	8	R1880	8	R1973	8
C1971	8	P191	12	R1881	8	R1990	8
C1972	8	Q1851	8	R1890	8	R1991	8
C1973	8	Q1852	8	R1891	8	R1992	8
C1980	8	Q1890	8	R1892	8	R1994	8
C1990	8	Q1980	8	R1893	8	T1970	8
C1991	8	Q1981	8	R1895	8	U1830	8
CR1894	8	R1812	8	R1896	8	U1890	8
CR1895	8	R1813	8	R1897	8	U1890	12
CR1915	8	R1833	6	R1898	8	U1956	8
CR1930	8	R1834	6	R1901	8	U1956	12
CR1950	8	R1842	6	R1910	8	VR1891	8
CR1953	8	R1848	8	R1911	8	W1909	12



Static Sensitive Devices
See Maintenance Section

COMPONENT NUMBER EXAMPLE

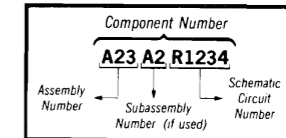

Chassis-mounted components have no Assembly Number prefix—see end of Replaceable Electrical Parts List.

A13—CRT TERMINATION BOARD

CIRCUIT NUMBER	SCHEM NUMBER	CIRCUIT NUMBER	SCHEM NUMBER
J904	8	R1501	8

HIGH VOLTAGE SUPPLY AND CRT DIAGRAM 8

ASSEMBLY A1											
CIRCUIT NUMBER	SCHEM LOCATION	BOARD LOCATION	CIRCUIT NUMBER	SCHEM LOCATION	BOARD LOCATION	CIRCUIT NUMBER	SCHEM LOCATION	BOARD LOCATION	CIRCUIT NUMBER	SCHEM LOCATION	BOARD LOCATION
C975	2C	9B	J120	2C	9A	J191	2D	10L			
<i>Partial A1 also shown on diagrams 4, 5, 6 and 11.</i>											
ASSEMBLY A9											
C91	9H	2A	DS90	8J	3A	R1855	5D	2D	R1944	7E	4C
C1812	5F	1A	DS91	8J	3A	R1856	5E	2D	R1945	6E	4C
C1813	6F	1A				R1857	5E	2D	R1950	8D	3C
C1886	8D	2D	J901	3H	2A	R1858	5E	2D	R1951	7B	3D
C1888	3G	1E	J901	5H	2A	R1864	3E	1D	R1952	7C	4D
C1889	8C	2E	J901	6L	2A	R1870	3G	1D	R1953	8D	3C
C1890	3G	2A	J902	2H	1F	R1871	5E	1D	R1971	6C	4D
C1891	3G	1B	J903	4H	1F	R1872	6E	1D	R1972	6E	4D
C1912	6M	4A	J904	5N	1F	R1873	3E	1D	R1973	7E	4D
C1915	7F	3A				R1878	8E	1E	R1990	4E	3E
C1932	7E	4B	L1921	7M	4B	R1880	4G	1E	R1991	8D	3E
C1950	8D	3D	L1974	9B	4E	R1881	8E	3E	R1992	9E	3E
C1951	7B	3D				R1890	4F	2E	R1994	8F	4E
C1971	8F	4D	P191	2D	4B	R1891	4F	2E			
C1972	9B	4E	P191	7A	4B	R1892	4E	2E	T1970	8C	3D
C1973	6D	4D				R1893	3E	2E			
C1980	8B	3E	Q1851	5E	1C	R1895	3F	1A	U1830	6G	2B
C1990	9D	3F	Q1852	5E	1D	R1896	3G	2A	U1890A	8D	2E
C1991	8F	4E	Q1890	4G	1E	R1897	3G	1B	U1890B	3F	2E
			Q1980	8F	3E	R1898	4H	1E	U1956A	7E	4C
			Q1981	8B	3E	R1901	6H	3A	U1956B	7D	4C
CR1894	8C	1E				R1910	6M	4A			
CR1895	8C	2E				R1911	6M	4A	VR1891	3F	1A
CR1915	7F	3A	R1812	5F	1A	R1913	7E	4B			
CR1930	8E	4B	R1813	6F	1A	R1920	7E	4B			
CR1950	8F	4D	R1848	4G	1C	R1922	7F	4A			
CR1953	8D	3D	R1853	5E	1D	R1941	8F	4C			
CR1990	8E	3E	R1854	6E	2D						
<i>Partial A9 also shown on diagrams 6 and 12.</i>											
ASSEMBLY A13											
J904	5M	5M	R1501	5L	5L						
OTHER PARTS											
LR1513	5L	CHASSIS	P901	6L	CHASSIS	R977	5A	CHASSIS	W900	7H	CHASSIS
LR1514	5L	CHASSIS	P902	2H	CHASSIS				W901	5H	CHASSIS
			P903	4H	CHASSIS	V900	1K	CHASSIS	W902	2H	CHASSIS
P120	2B	CHASSIS							W903	4H	CHASSIS
P901	3H	CHASSIS	R975	2A	CHASSIS	W900	3H	CHASSIS			
P901	5H	CHASSIS	R976	5A	CHASSIS	W900	6L	CHASSIS			

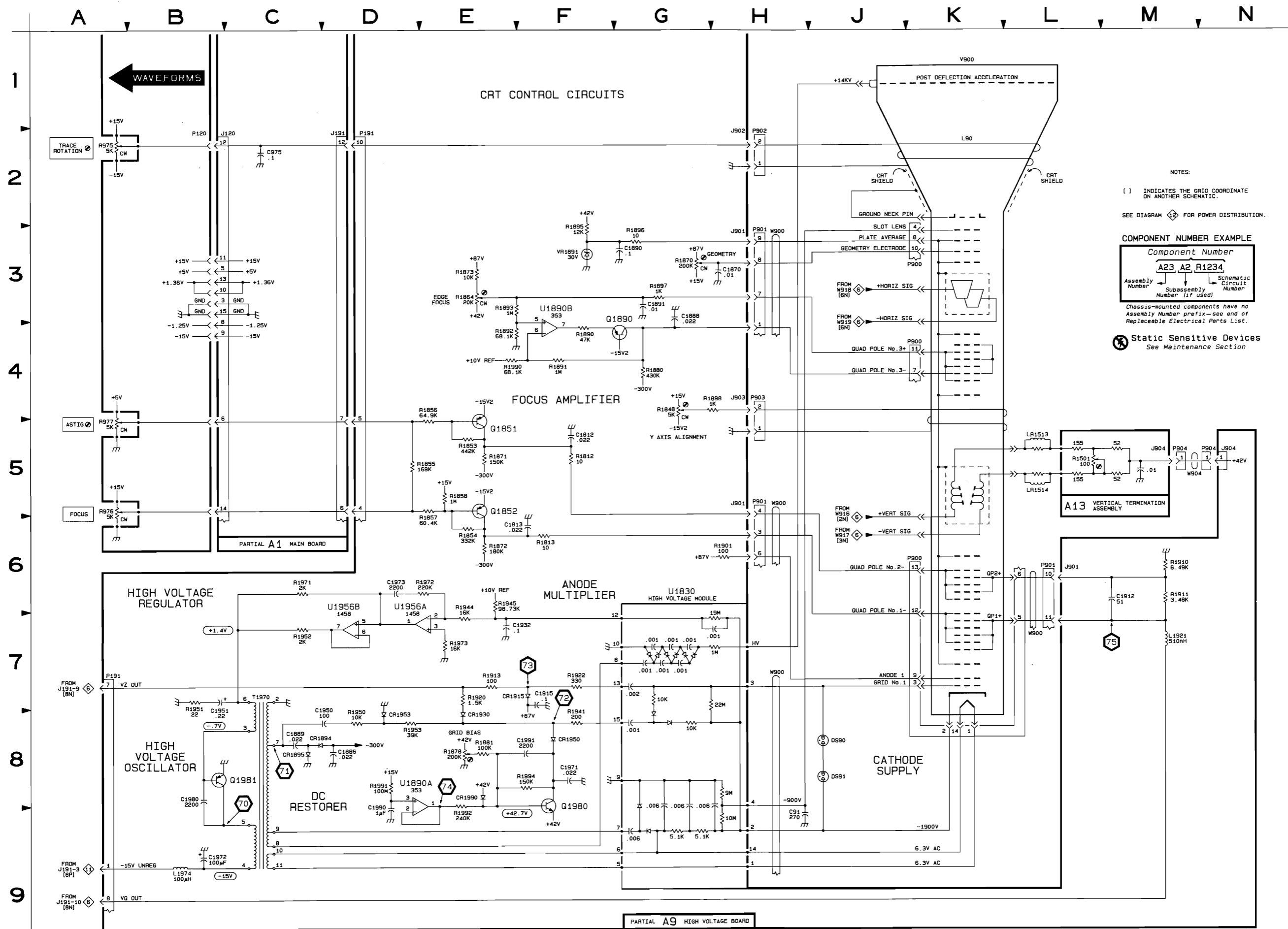

NOTES:
 () INDICATES THE GRID COORDINATE ON ANOTHER SCHEMATIC.
 SEE DIAGRAM FOR POWER DISTRIBUTION.
COMPONENT NUMBER EXAMPLE
 Component Number
 A23 A2 R1234
 Assembly Number Subassembly Number (if used) Schematic Circuit Number
 Chassis-mounted components have no Assembly Number prefix—see end of Replaceable Electrical Parts List.
 Static Sensitive Devices
 See Maintenance Section

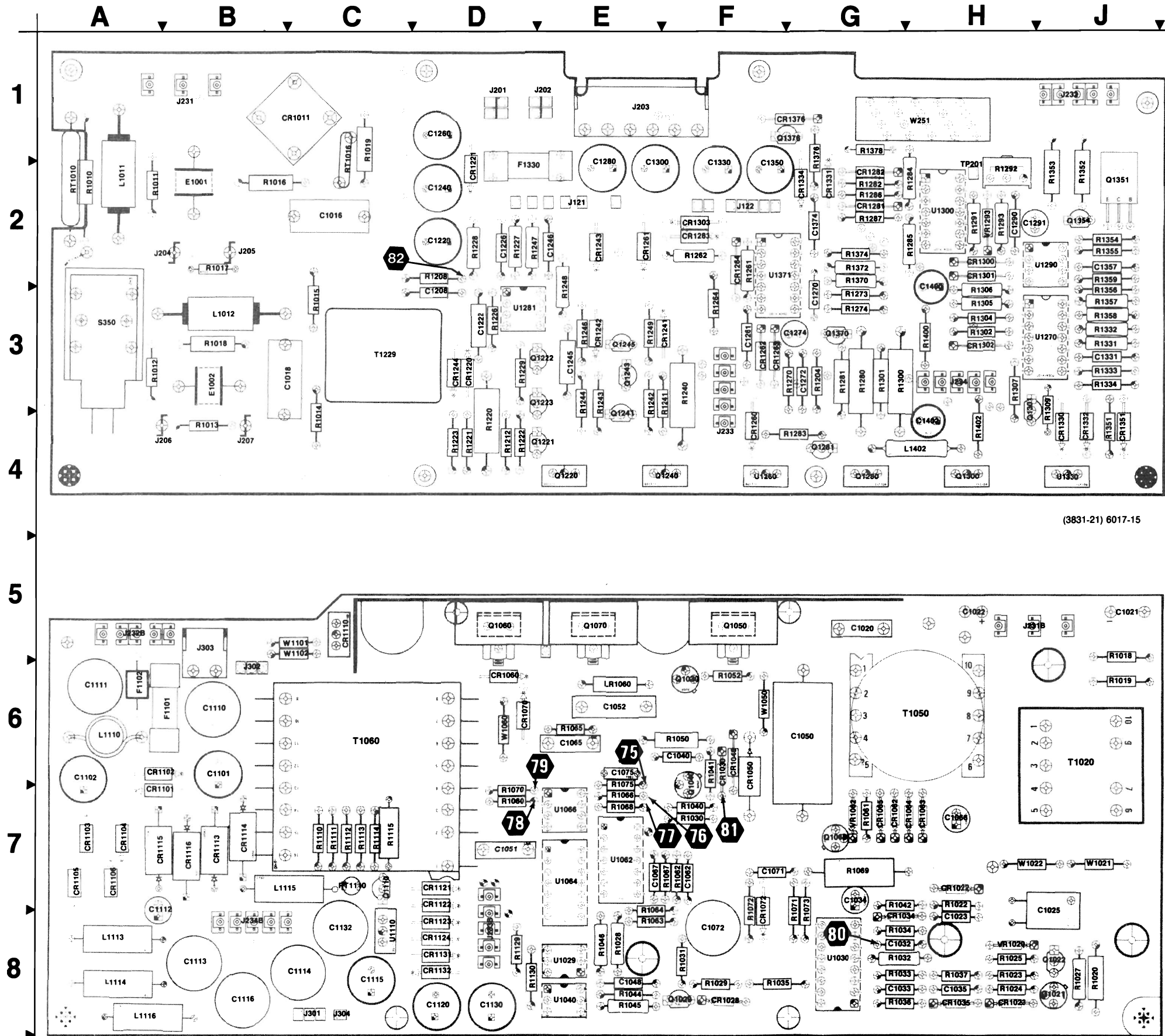

(3831-21) 6017-15

← A 2

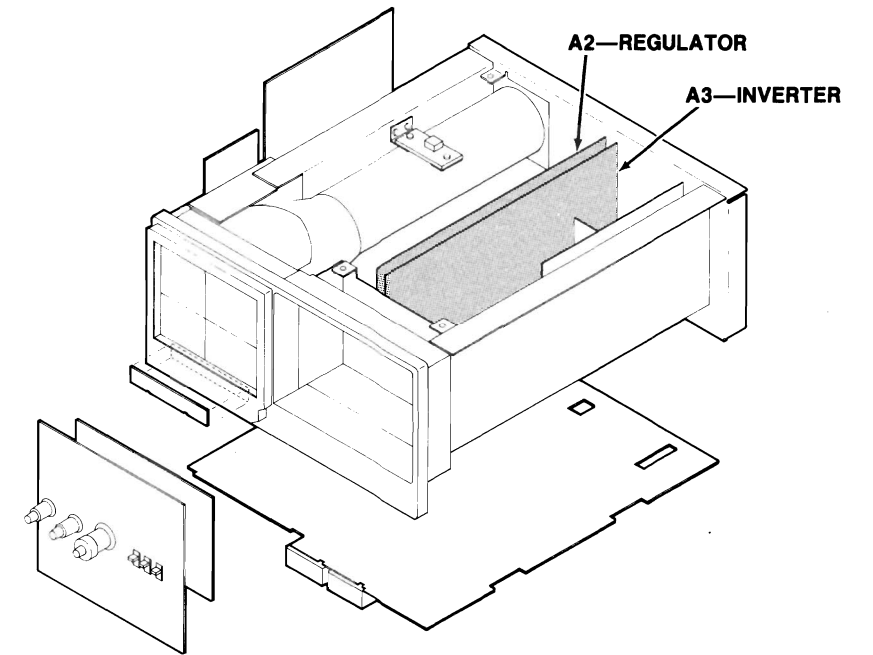

← A 3

⊗ Static Sensitive Devices
See Maintenance Section

COMPONENT NUMBER EXAMPLE

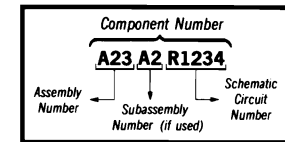

Chassis-mounted components have no Assembly Number prefix—see end of Replaceable Electrical Parts List.

Figure 10-11. A2—Regulator and A3—Inverter boards.

A3—INVERTER BOARD

CIRCUIT NUMBER	SCHEM NUMBER	CIRCUIT NUMBER	SCHEM NUMBER	CIRCUIT NUMBER	SCHEM NUMBER	CIRCUIT NUMBER	SCHEM NUMBER
C1020	9	CR1040	9	L1116	9	R1062	9
C1021	9	CR1050	9	LR1060	9	R1063	9
C1022	9	CR1060	9	Q1021	9	R1064	9
C1023	9	CR1062	9	Q1022	9	R1065	9
C1025	9	CR1063	9	Q1029	9	R1066	9
C1032	9	CR1064	9	Q1030	9	R1067	9
C1033	9	CR1065	9	Q1040	9	R1068	9
C1034	9	CR1070	9	Q1050	9	R1069	9
C1035	9	CR1072	9	Q1060	9	R1070	9
C1040	9	CR1101	9	Q1062	9	R1071	9
C1048	9	CR1102	9	Q1070	9	R1072	9
C1050	9	CR1103	9	Q1110	9	R1073	9
C1051	9	CR1104	9	R1018	9	R1075	9
C1052	9	CR1105	9	R1019	9	R1110	9
C1062	9	CR1106	9	R1020	9	R1111	9
C1065	9	CR1110	9	R1022	9	R1112	9
C1066	9	CR1113	9	R1023	9	R1113	9
C1067	9	CR1114	9	R1024	9	R1114	9
C1071	9	CR1115	9	R1025	9	R1115	9
C1072	9	CR1116	9	R1027	9	R1129	9
C1075	9	CR1121	9	R1028	9	R1130	9
C1101	9	CR1122	9	R1029	9	RT1110	9
C1102	9	CR1123	9	R1030	9	T1020	9
C1110	9	CR1124	9	R1031	9	T1050	9
C1111	9	CR1131	9	R1032	9	T1060	9
C1112	9	CR1132	9	R1033	9	U1029	9
C1112	9	F1101	9	R1034	9	U1030	9
C1113	9	F1102	9	R1035	9	U1040	9
C1114	9	J231	9	R1036	9	U1062	9
C1115	9	J232	9	R1037	9	U1064	9
C1116	9	J233	9	R1040	9	U1066	9
C1120	9	J234	9	R1041	9	U1110	9
C1130	9	J301	9	R1042	9	VR1020	9
C1132	9	J302	9	R1044	9	VR1062	9
CR1022	9	J303	9	R1045	9	W1021	9
CR1023	9	J304	9	R1046	9	W1022	9
CR1028	9	L1110	9	R1050	9	W1050	9
CR1030	9	L1113	9	R1052	9	W1060	9
CR1034	9	L1114	9	R1060	9	W1101	9
CR1035	9	L1115	9	R1061	9	W1102	9

LOW-VOLTAGE POWER SUPPLY AND FAN CIRCUIT DIAGRAM 9

ASSEMBLY A2											
CIRCUIT NUMBER	SCHEM LOCATION	BOARD LOCATION	CIRCUIT NUMBER	SCHEM LOCATION	BOARD LOCATION	CIRCUIT NUMBER	SCHEM LOCATION	BOARD LOCATION	CIRCUIT NUMBER	SCHEM LOCATION	BOARD LOCATION
C1016	6D	2C	J204	5B	2B	R1011	5C	2A	RT1010	5C	2A
C1018	6C	3C	J205	6B	2B	R1012	6C	3A	RT1016	6D	1C
C1208	3C	3D	J206	6B	4B	R1013	6C	4B			
			J207	6B	4B	R1014	3C	4C	S350	5B	3A
CR1011	5D	1C	J231A	5D	1B	R1015	3C	3C			
						R1016	6D	2B	T1229	3C	3C
E1001	6C	2B	L1011	5C	2A	R1017	6B	2B			
E1002	6D	3B	L1012	6C	3B	R1018	6C	3B			
						R1019	6D	1C			
J122	3D	2F	R1010	5C	2A	R1208	3C	2D			
<i>Partial A2 also shown on diagram 10.</i>											
ASSEMBLY A3											
C1020	4E	5G	CR1063	7G	7H	Q1029	3N	8F	R1070	9K	6D
C1021	7E	5J	CR1064	7F	7H	Q1030	6H	6F	R1071	6H	7G
C1022	5E	5H	CR1065	7G	7G	Q1040	6J	6F	R1072	6H	7F
C1023	4G	8H	CR1070	7L	6D	Q1050	6G	5F	R1073	7H	7G
C1025	3F	7J	CR1072	6G	7F	Q1060	8K	5D	R1075	8G	6E
C1032	4L	8H	CR1101	9M	7B	Q1062	7H	7G	R1110	2M	7C
C1033	5L	8H	CR1102	9M	6B	Q1070	9K	5E	R1111	2M	7C
C1034	3L	7G	CR1103	8N	7A	Q1110	2L	7C	R1112	2M	7C
C1035	5L	8H	CR1104	8N	7A				R1113	2L	7C
C1040	6J	6F	CR1105	7N	7A	R1018	7E	5J	R1114	2L	7C
C1048	4M	8E	CR1106	7N	7A	R1019	6E	6J	R1115	1L	7C
C1050	6G	6G	CR1110	7M	6C	R1020	3F	8J	R1129	4N	8D
C1051	6F	7D	CR1113	8M	7B	R1022	3G	7H	R1130	4N	8E
C1052	6G	6E	CR1114	8M	7B	R1023	3G	8H			
C1062	9F	7F	CR1115	7M	7B	R1024	3H	8H	RT1110	2M	7C
C1065	6L	6E	CR1116	7M	7B	R1025	3G	8H			
C1066	8G	7H	CR1121	6M	7D	R1027	3M	8J	T1020	6E	6J
C1067	9F	7E	CR1122	6M	7D	R1028	3M	8E	T1050	6F	6H
C1071	6H	7F	CR1123	6M	8D	R1029	3N	8F	T1060	6L	6C
C1072	7J	8F	CR1124	6M	8D	R1030	6H	7F			
C1075	8J	6E	CR1131	5M	8D	R1031	4L	8F	U1029	3N	8E
C1101	9M	6B	CR1132	5M	8D	R1032	4L	8H	U1030	5K	8G
C1102	9M	6A				R1033	5L	8H	U1040	4M	8E
C1110	9M	6B	F1101	8N	6B	R1034	3L	8H	U1062A	8H	7E
C1111	9M	6A	F1102	9N	6A	R1035	4L	8G	U1062B	9H	7E
C1112	8N	7B				R1036	5L	8H	U1062C	9F	7E
C1112	8N	7B	J2318	5E	5J	R1037	4L	8H	U1062D	9G	7E
C1113	8N	8B	J232B	9P	5A	R1040	6H	7F	U1062	8H	7E
C1114	8N	8C	J2338	4P	8D	R1041	6H	6F	U1064A	9G	7E
C1115	7N	8C	J234B	7P	8B	R1042	3H	7H	U1064B	9G	7E
C1116	7N	8B	J301	6P	8C	R1044	4M	8E	U1064	8H	7E
C1120	6M	8D	J302	6P	6B	R1045	4M	8E	U1066A	8J	7D
C1130	5M	8D	J303	8P	5B	R1046	5M	8E	U1066B	9J	7D
C1132	5M	8C	J304	1N	8C	R1050	6H	6F	U1066	8J	7D
						R1052	6G	6F	U1110	1L	8C
CR1022	3F	7H	L1110	9M	6A	R1060	8K	7D			
CR1023	3H	8H	L1113	8N	8A	R1061	7G	7G	VR1020	4G	8H
CR1028	3N	8F	L1114	8N	8A	R1062	8F	7F	VR1062	7G	7G
CR1030	6H	6F	L1115	7N	7C	R1063	9F	8E			
CR1034	4L	8H	L1116	7N	8A	R1064	9F	7E	W1021	7E	7J
CR1035	5L	8H				R1065	6L	6E	W1022	6E	7J
CR1040	6H	6F	LR1060	8K	6E	R1066	8J	7E	W1050	6G	6F
CR1050	6G	6F				R1067	8F	7F	W1060	6L	6D
CR1060	6L	6D	Q1021	3G	8J	R1068	8J	7E	W1101	6N	5C
CR1062	7F	7G	Q1022	4G	8J	R1069	7H	7G	W1102	6N	5C
OTHER PARTS											
810	1P	CHASSIS	P204	5B	CHASSIS	P232	9P	CHASSIS	S1020	5E	CHASSIS
			P205	6B	CHASSIS	P233	4P	CHASSIS			
C10	1N	CHASSIS	P206	6B	CHASSIS	P234	7P	CHASSIS			
			P207	6B	CHASSIS						
F90	5A	CHASSIS	P231	5E	CHASSIS	S90	6A	CHASSIS			

A B C D E F G H J K L M N P

1
2
3
4
5
6
7
8
9

← WAVEFORMS

LINE SIGNAL

FAN CIRCUIT

NOTES:
* INDICATES VOLTAGE WITH RESPECT TO REF1
** INDICATES VOLTAGE WITH RESPECT TO REF2
[] INDICATES THE GRID COORDINATE ON ANOTHER SCHEMATIC.

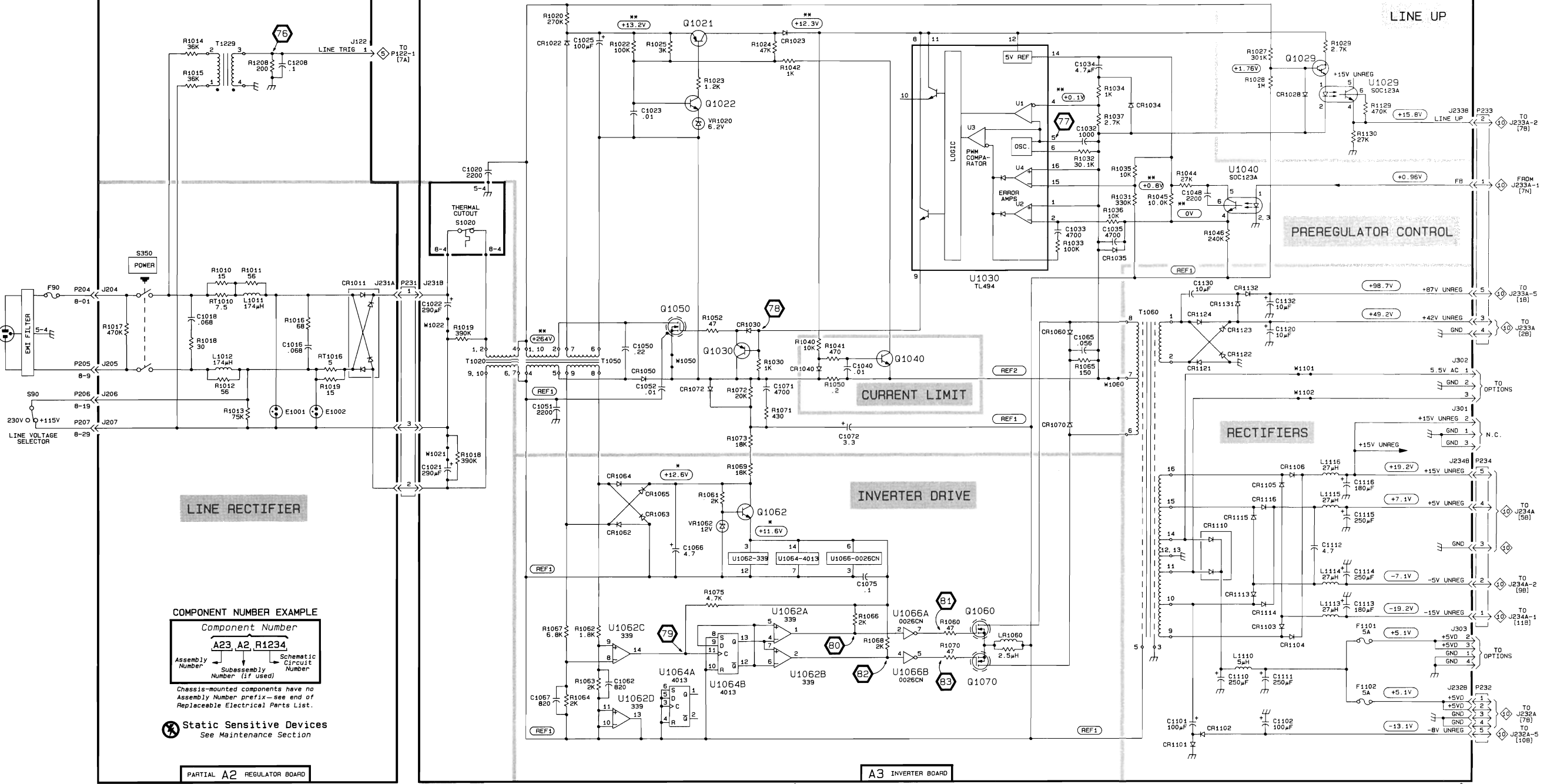

COMPONENT NUMBER EXAMPLE
Component Number
A23 A2 R1234
Assembly Number Subassembly Number (if used) Schematic Circuit Number
Chassis-mounted components have no Assembly Number prefix—see end of Replaceable Electrical Parts List.

⚡ Static Sensitive Devices
See Maintenance Section

PARTIAL A2 REGULATOR BOARD

A3 INVERTER BOARD

LOW-VOLTAGE REGULATORS DIAGRAM 10



ASSEMBLY A2											
CIRCUIT NUMBER	SCHEM LOCATION	BOARD LOCATION	CIRCUIT NUMBER	SCHEM LOCATION	BOARD LOCATION	CIRCUIT NUMBER	SCHEM LOCATION	BOARD LOCATION	CIRCUIT NUMBER	SCHEM LOCATION	BOARD LOCATION
C1220	2L	2D	CR1334	9L	2G	R1223	1D	4D	R1352	10J	2J
C1222	1D	3D	CR1351	10G	4J	R1226	2C	3D	R1353	10J	2J
C1226	2D	2D	CR1376	8H	1G	R1227	2D	2D	R1354	10J	2J
C1240	3L	2D				R1228	2D	2D	R1355	10J	2J
C1245	3F	3E	F1330	11F	2E	R1229	1C	3D	R1356	10G	3J
C1246	3F	2E				R1240	3G	3F	R1357	10K	3J
C1260	5L	1D	J121	1N	2E	R1241	3G	3F	R1358	9H	3J
C1261	4J	3F	J122	3N	2F	R1242	3G	3F	R1359	10G	2J
C1270	7K	3G	J201	4N	1D	R1243	3G	3E	R1370	8G	2G
C1272	7K	3G	J202	5N	1E	R1244	3F	3E	R1372	8G	2G
C1274	7K	3G	J203	6N	1F	R1246	3F	3E	R1374	7G	2G
C1280	6L	2E	J232A	10B	1J	R1247	3F	2E	R1376	8H	1G
C1290	6D	2H	J232A	7B	1J	R1248	4F	3E	R1378	7H	1G
C1291	6E	2J	J233A	1B	3F	R1249	3F	3F	R1400	5C	3H
C1300	8L	2F	J233A	7B	3F	R1261	4H	2F	R1402	9C	4H
C1330	11L	2F	J233A	7N	3F	R1262	5H	2F			
C1331	11F	3J	J234A	11B	3H	R1264	4H	3F	TP201	6F	2H
C1350	9L	2F	J234A	5B	3H	R1270	7K	3G			
C1357	10H	2J	J234A	9B	3H	R1273	7J	3G	U1260	5J	4F
C1374	8G	2G				R1274	7K	3G	U1270A	8J	3J
C1400	6C	3H	L1402	9C	4H	R1280	6K	3G	U1270B	8J	3J
C1402	9C	4H				R1281	6K	3G	U1270C	11F	3J
			Q1220	1E	4E	R1282	6K	2G	U1270D	10H	3J
CR1220	2E	3D	Q1221	1D	4E	R1283	6J	4G	U1270	6C	3J
CR1221	2L	2D	Q1222	2C	3E	R1284	7J	2H	U1281A	2D	3D
CR1241	3G	3F	Q1223	1D	3E	R1285	7J	2H	U1281B	4F	3D
CR1242	3F	3E	Q1240	3G	4F	R12B6	6K	2G	U1281	7C	3D
CR1243	4L	2E	Q1241	3F	4E	R1287	6J	2G	U1290	6D	2J
CR1244	2D	3D	Q1243	3F	3E	R1291	6E	2H	U1300A	6J	2H
CR1260	5J	4F	Q1245	3F	3E	R1292	6E	2H	U1300B	6J	2H
CR1261	6L	2E	Q1280	6K	4G	R1293	6E	2H	U1300C	6E	2H
CR1262	4J	3F	Q1281	6J	4G	R1300	8K	3H	U1300D	6E	2H
CR1263	5J	3G	Q1300	9K	4H	R1301	8K	3G	U1300	7C	2H
CR1264	4H	2F	Q1301	9J	4J	R1302	8K	3H	U1330	11E	4J
CR1281	6J	2G	Q1351	10J	2J	R1304	9J	4J	U1371A	4J	2G
CR1282	6J	2G	Q1354	10H	2J	R1305	8K	3H	U1371B	5H	2G
CR1283	6L	2F	Q1370	7F	3G	R1306	8K	3H	U1371C	7K	2G
CR1300	8J	2H	Q1376	8H	1G	R1307	9J	3H	U1371D	8G	2G
CR1301	8J	2H				R1309	9J	3H	U1371	7C	2G
CR1302	8J	3H	R1204	8F	3G	R1331	11F	3J			
CR1303	8L	2F	R1212	1C	4D	R1332	11F	3J	VR1293	6F	2H
CR1330	11E	4J	R1220	1E	4D	R1333	11E	3J			
CR1331	10L	2G	R1221	1E	4D	R1334	11E	3J	W251	11N	1H
CR1332	11E	4J	R1222	1D	4D	R1351	10G	4J			

Partial A2 also shown on diagram 9.

OTHER PARTS											
P251	7N	CHASSIS									

A B C D E F G H J K L M N

1
2
3
4
5
6
7
8
9
10
11

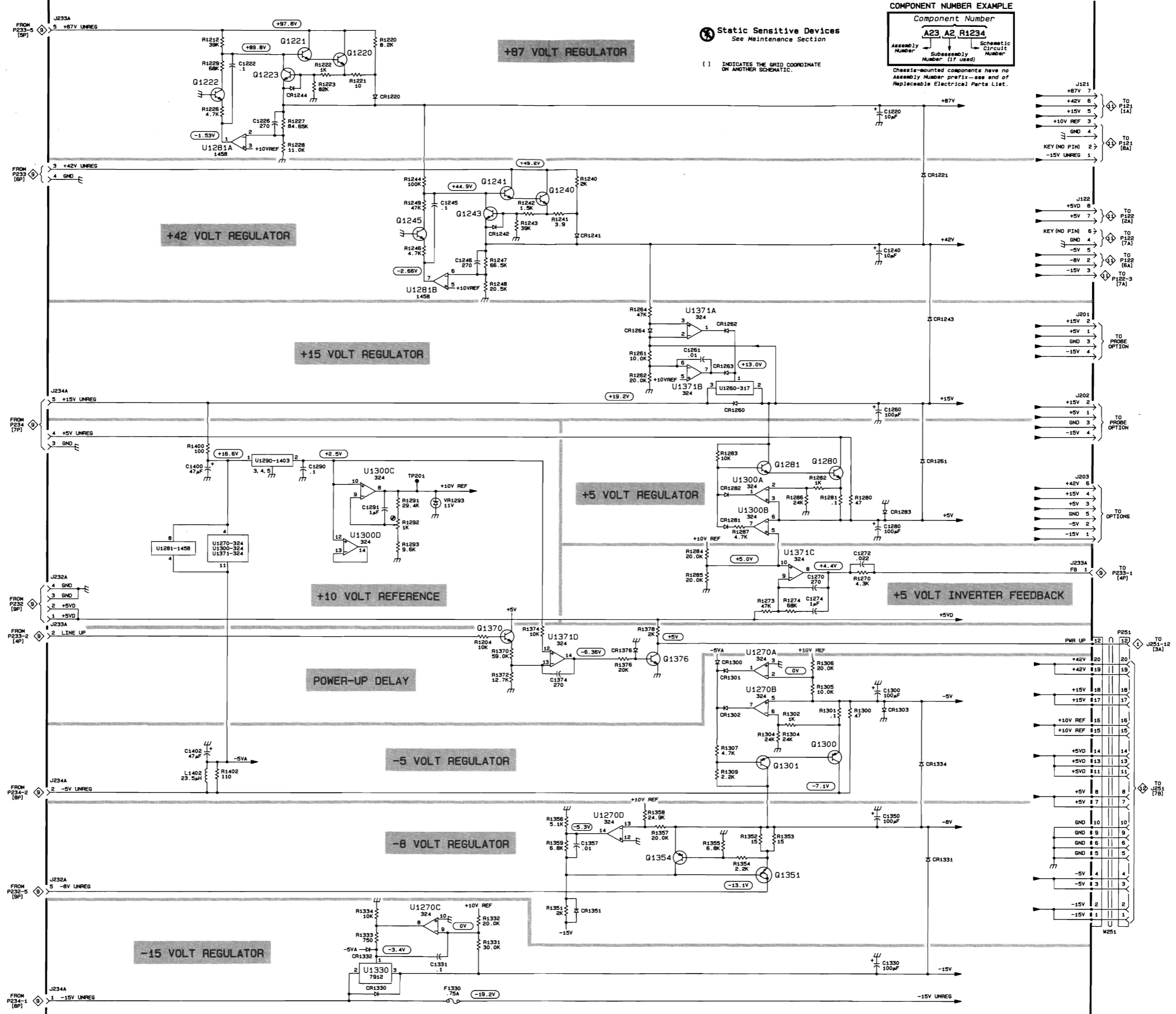

Static Sensitive Devices
See Maintenance Section

(1) INDICATES THE GRID COORDINATE ON ANOTHER SCHEMATIC.

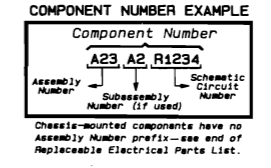

+87 VOLT REGULATOR

+42 VOLT REGULATOR

+15 VOLT REGULATOR

+5 VOLT REGULATOR

+10 VOLT REFERENCE

+5 VOLT INVERTER FEEDBACK

POWER-UP DELAY

-5 VOLT REGULATOR

-8 VOLT REGULATOR

-15 VOLT REGULATOR

PARTIAL A2 REGULATOR BOARD

POWER DISTRIBUTION A DIAGRAM 11

ASSEMBLY A1											
CIRCUIT NUMBER	SCHEM LOCATION	BOARD LOCATION	CIRCUIT NUMBER	SCHEM LOCATION	BOARD LOCATION	CIRCUIT NUMBER	SCHEM LOCATION	BOARD LOCATION	CIRCUIT NUMBER	SCHEM LOCATION	BOARD LOCATION
C102	6A	7D	C738	7G	8E	L120	2B	7E	U150	3K	8C
C106	6B	7D	C740	6G	8D	L219	7B	3C	U160	2C	2D
C107	6B	6D	C810	2L	8G	L220	2B	3C	U165	3K	2F
C108	7B	7D	C811	3L	8G	L307	6D	3B	U170	4K	2E
C113	3B	7D	C819	6L	9F	L325	3D	3B	U180	3C	2E
C114	3B	6D	C850	6L	8F	L336	3D	1C	U200	4B	4D
C119	6B	5B	C903	3K	7L	L521	6E	3J	U300	4D	2B
C120	2B	7E	C933	2L	10G	L733	2G	7E	U350	2L	10B
C121	2B	6E	C938	7L	10H	L738	7G	7E	U400	4D	5F
C125	4A	7C	C940	6L	10H	L740	6G	7E	U450	2L	4F
C207	6A	6C	C943	3L	10J	L743	3G	7D	U500	4E	3G
C209	5C	4C	C958	3L	8L	L938	6J	7K	U600	4F	7J
C210	3C	4E	C966	1L	10L	L973	7L	10L	U650	4F	4K
C218	7C	3D	C967	1L	10L				U700	4G	9D
C219	7C	3D	C973	7L	10L	LR101	5A	6C	U800	4J	9F
C220	2C	3C	C980	3K	7L	LR107	5C	7E	U850	4K	9F
C221	2C	3D	C988	6J	8L	LR201	5B	6C	U860	4K	7G
C225	4B	3C	C990	2L	9L	LR218	6C	3D	U900	4H	10H
C307	6D	3B				LR219	6C	3E	U910	2F	10F
C325	3D	3C	CR107	6B	5J				U950	4J	9L
C336	3D	1C	CR807	4J	9G	Q700	1G	10C	U975	3K	7L
C415	7L	5G	CR811	2H	8G				U980	3K	7L
C458	2L	3F	CR987	4J	9L						
C480	2L	3K				R125	3B	7D	VR125	3A	7D
C500	4E	3G	J119	6P	4J	R225	3B	3C	VR225	3B	3C
C501	5E	3G	J191	1P	10L	R700	1G	10C			
C521	6L	2J	J191	8P	10L	R701	1F	10C			
C675	3L	4J	J411	2P	1L	R702	2F	10D			
C710	2F	10D	J511	4P	1D	R811	2H	8G	W101	7B	10B
C722	3G	8D	J511	8A	1D	R951	8N	10K	W102	7B	5L
C723	3G	8D	J512	9A	1J				W103	7B	8H
C730	8C	8B				U100	4B	6D	W104	7B	3L
C731	8C	9F	L101	6B	BC	U110	2B	7B	W105	7B	5G
C732	8B	9B	L107	6B	7D	U120	2B	7C	W109	8B	10L
C733	2G	8E	L113	3B	7D	U130	2B	7C	W121	2A	5J
						U140	3K	8B	W121	8A	5J
									W122	7A	5J

Partial A1 also shown on diagrams 4, 5, 6 and 8.

OTHER PARTS											
P121	1A	CHASSIS	P121	8A	CHASSIS	P122	2A	CHASSIS			

POWER DISTRIBUTION A



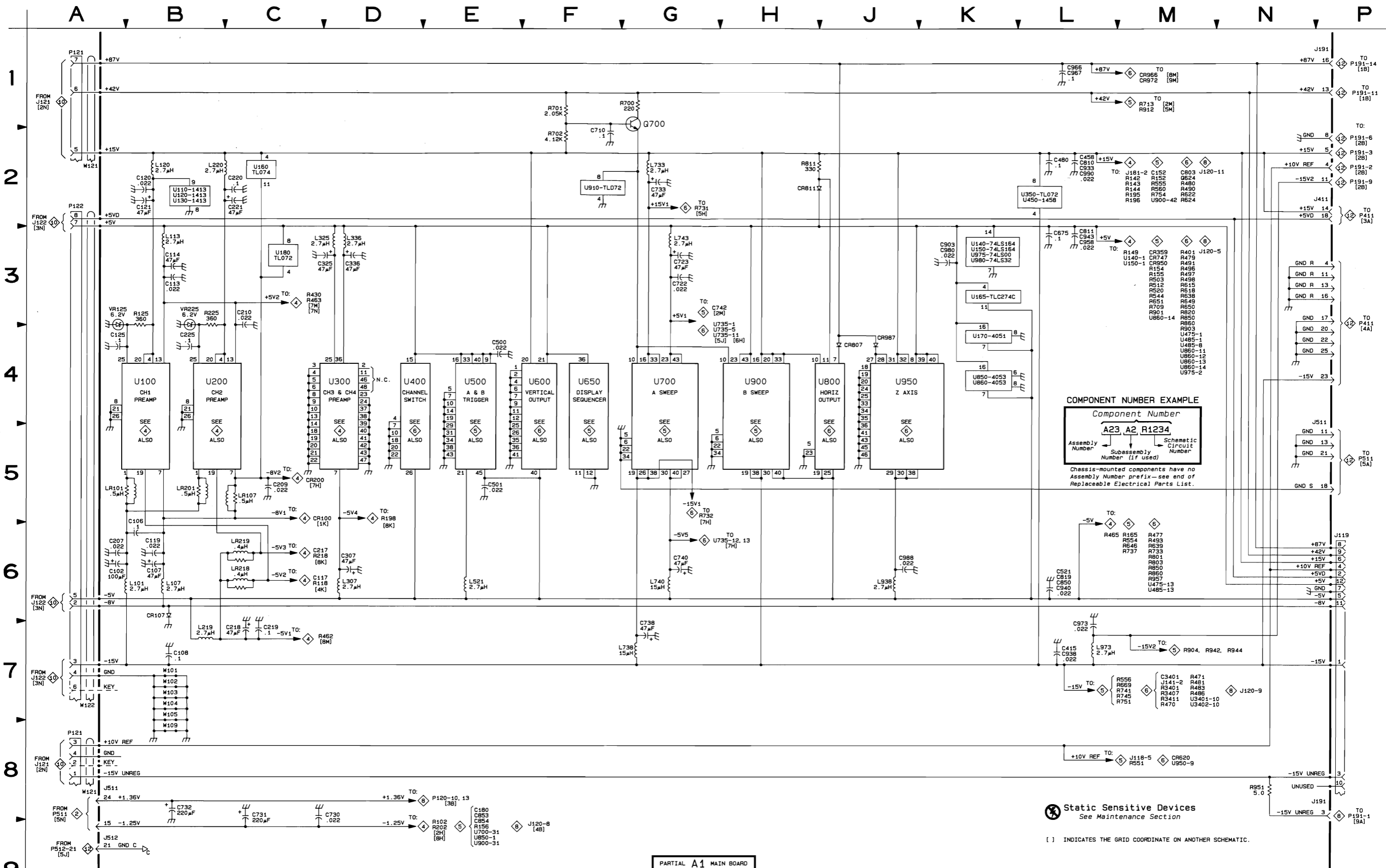

COMPONENT NUMBER EXAMPLE

Component Number
A23 A2 R1234

Assembly Number Subassembly Number (if used) Schematic Circuit Number

Chassis-mounted components have no Assembly Number prefix—see end of Replaceable Electrical Parts List.

Static Sensitive Devices
 See Maintenance Section

[] INDICATES THE GRID COORDINATE ON ANOTHER SCHEMATIC.

POWER DISTRIBUTION A

11

POWER DISTRIBUTION B DIAGRAM 12

ASSEMBLY A4											
CIRCUIT NUMBER	SCHEM LOCATION	BOARD LOCATION	CIRCUIT NUMBER	SCHEM LOCATION	BOARD LOCATION	CIRCUIT NUMBER	SCHEM LOCATION	BOARD LOCATION	CIRCUIT NUMBER	SCHEM LOCATION	BOARD LOCATION
C2830	3B	1C	C2980	4B	2F	U2860	3F	2D	U2960	3G	2E
C2835	3B	2C	C2990	4B	3F	U2870	4H	2E	U2965	4H	3E
C2851	3B	1D				U2880	4H	1F	U2970	4H	3E
C2855	4B	2D	R2805	3C	2B	U2885	4H	2F	U2980	4H	2F
C2860	4B	2D				U2890	4H	2F	U2985	3G	3F
C2885	4B	2E	U2800	3D	1B	U2900	4H	2A	U2990	4H	3F
C2901	4B	2B	U2805	3D	2B	U2905	3D	3A	U2995	4H	4F
C2913	5B	4B	U2810	3H	2A	U2910	3D	3A			
C2926	4B	3C	U2820	3C	2A	U2920	3E	3C	VR2805	4C	1B
C2940	3B	4C	U2830	3H	1C	U2930	3F	3D			
C2950	4B	4D	U2835	3H	2C	U2935	3F	3C	W411	5A	1B
C2960	4B	2E	U2850	4H	1D	U2940	4H	4C	W2913	4B	4B
C2970	4B	3D	U2855	4H	1D	U2950	4H	4D			
<i>Partial A4 also shown on diagram 7.</i>											
ASSEMBLY A5											
C2011	7B	1C	C2601	7C	4B	U2160	7E	1J	U2521	7G	3E
C2101	7C	1B	C2610	8B	4C	U2201	7E	2B	U2530	7G	3E
C2111	7C	1C	C2620	8C	3C	U2210	7D	2C	U2540	7H	3G
C2112	8C	1C	C2632	8C	3F	U2220	7E	2D	U2550	7G	3H
C2113	8B	1C	C2650	7C	4H	U2240	7F	2G	U2601	7G	4B
C2160	7C	1J	C2660	7C	4J	U2250	7E	2H	U2620	6C	4D
C2220	7B	2D	C2740	8B	4G	U2260	7E	2J	U2630	6C	4E
C2221	6C	2E				U2301	7E	2B	U2640	7G	4G
C2320	8B	2D	J251	6B	1D	U2401	7G	2B	U2650	7G	4H
C2331	6B	2E	J652	6H	2A	U2410	7G	2C	U2660	7E	4K
C2450	7C	2H				U2420	6C	2D			
C2501	7C	3B	TP2070	5H	1K	U2430	6C	2E	W511	6B	4C
C2510	7C	3C	TP2701	5G	4A	U2440	7H	2G	W512	5H	4H
C2520	6C	3D				U2501	7G	3B	W2070	5H	1K
C2530	6C	3F	U2101	7D	1B	U2510	7D	3C	W2610	5G	4C
C2552	7C	3H	U2140	7D	1G	U2520	6D	3D	W2701	5F	4A
<i>Partial A5 also shown on diagrams 1 and 2.</i>											
ASSEMBLY A6											
C3001	7J	4A	U3001	7K	3B	U3004	7K	3D	W652	7J	3A
C3002	7J	3F	U3002	7K	2C	U3005	7K	2F			
C3019	7J	4D	U3003	7K	3C	U3006	7K	3F			
<i>Partial A6 also shown on diagram 3.</i>											
ASSEMBLY A9											
P191	1B	4B	U1890 U1956	2D 2D	2E 4C	W1909	2B	2A			
<i>Partial A9 also shown on diagrams 6 and 8.</i>											
OTHER PARTS											
P411	3A	CHASSIS	P511	5A	CHASSIS	P512	5J	CHASSIS	P652	6H	CHASSIS

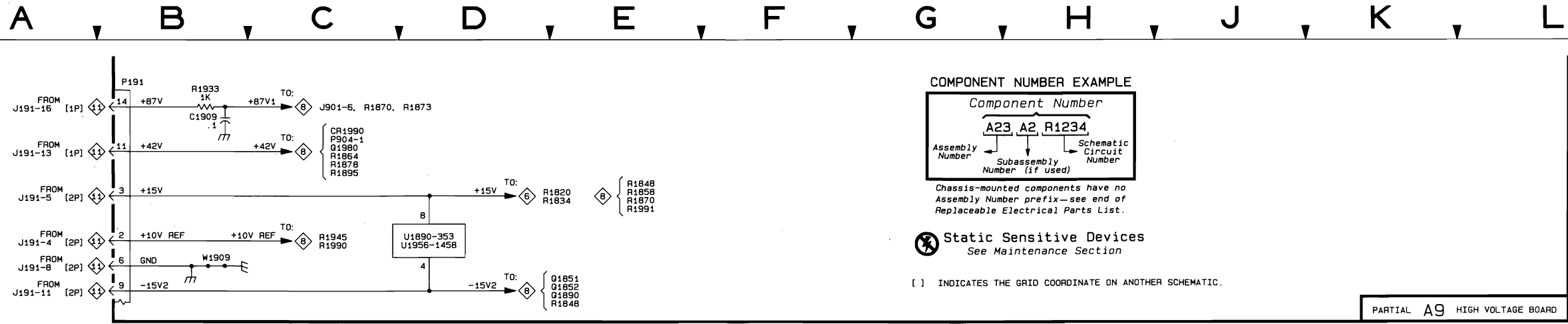

PARTIAL A9 HIGH VOLTAGE BOARD

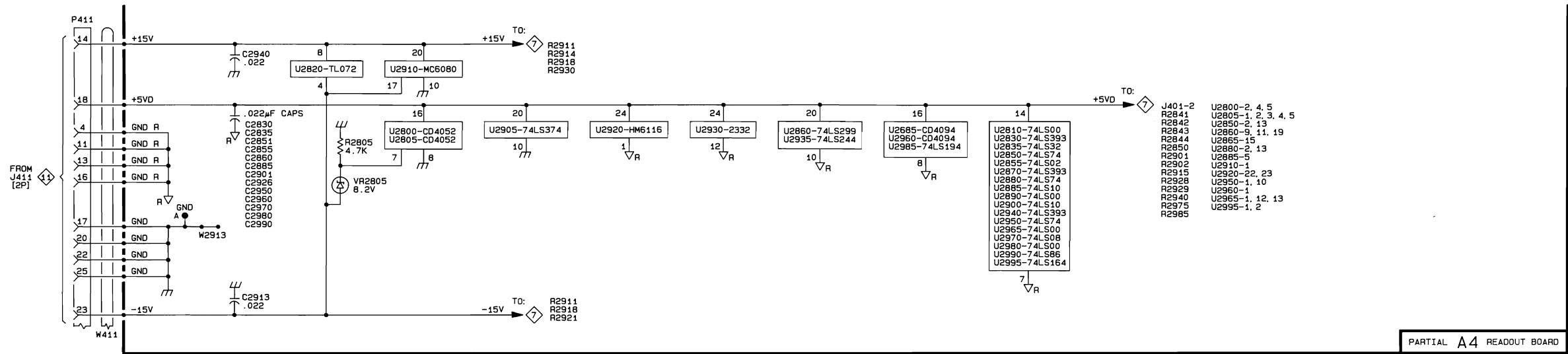

PARTIAL A4 READOUT BOARD

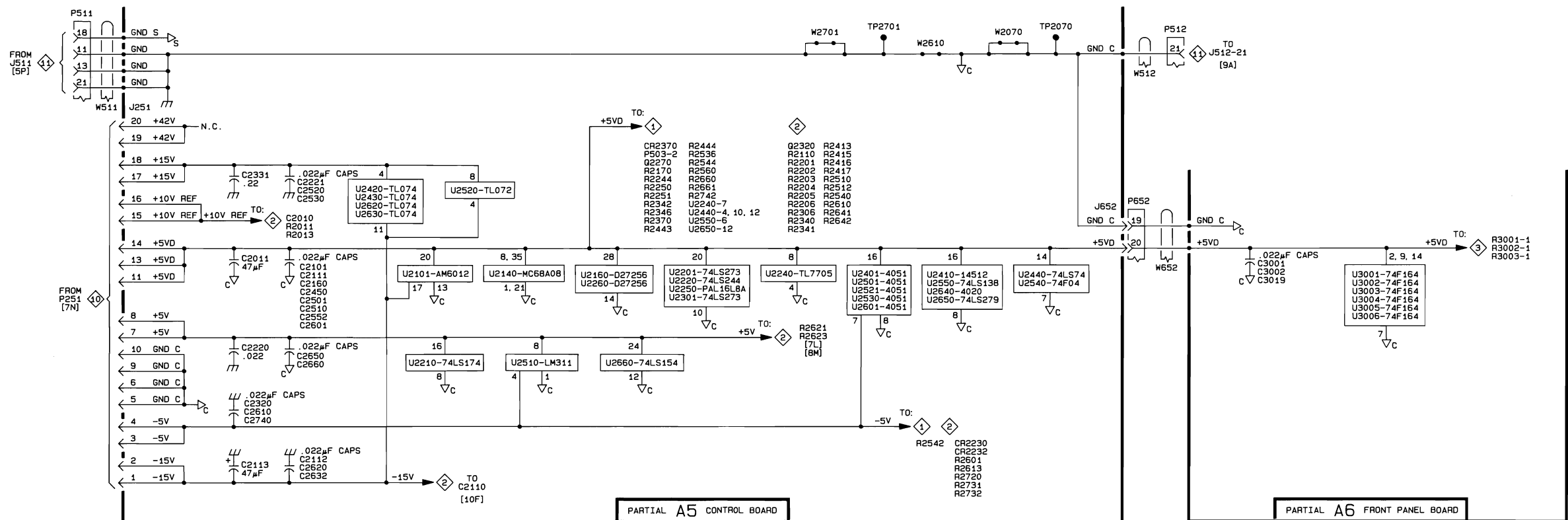

PARTIAL A5 CONTROL BOARD

PARTIAL A6 FRONT PANEL BOARD

A B C D E F G H J K L M

1
2
3
4
5
6
7
8
9

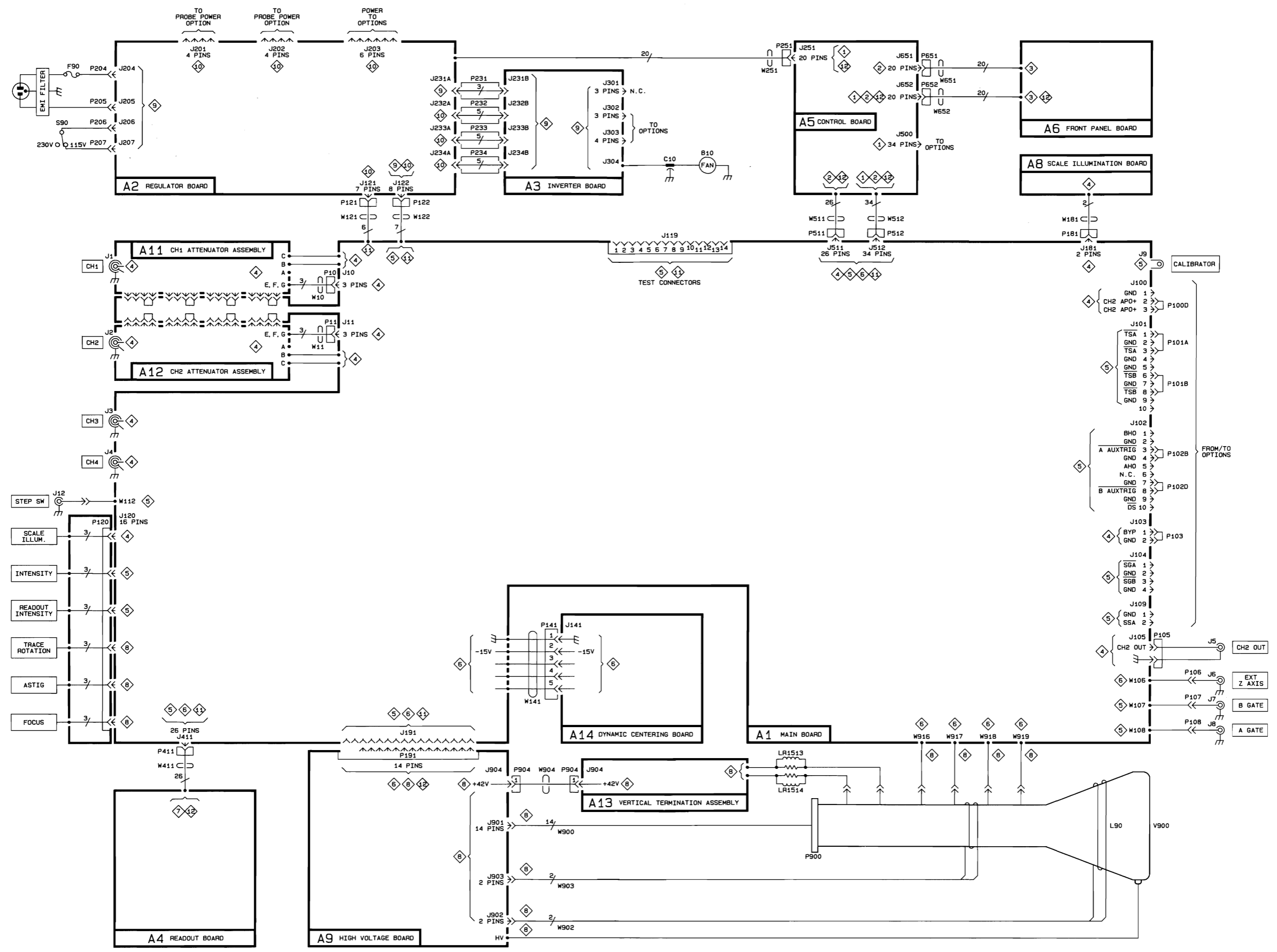

OTHER PARTS

CIRCUIT NUMBER	SCHEM LOCATION	BOARD LOCATION	CIRCUIT NUMBER	SCHEM LOCATION	BOARD LOCATION	CIRCUIT NUMBER	SCHEM LOCATION	BOARD LOCATION	CIRCUIT NUMBER	SCHEM NUMBER	SCHEM LOCATION
B10	9	1P	P120	8	2B	P512	2	3N	R3011	3	6M
			P121	11	1A	P512	2	6A	R3012	3	5M
C10	9	1N	P121	11	8A	P512	2	8N	R3013	3	8M
			P122	11	2A	P651	3	1N	R3014	3	2M
F90	9	5A	P122	5	7A	P652	12	6H	R3015	3	1M
			P141	6	5F	P652	3	10N	R3016	3	7M
J1	4	1A	P141	6	7C	P652	3	1A	R3017	3	3M
J2	4	7A	P181	4	4N	P901	8	3H	R3018	3	6M
J3	4	9A	P204	9	5B	P901	8	5H	R3019	3	4M
J4	4	10A	P205	9	6B	P901	8	6L			
J5	4	7P	P206	9	6B	P902	8	2H	S90	9	6A
J6	6	9A	P207	9	6B	P903	8	4H	S1020	9	5E
J7	5	6S	P231	9	5E						
J8	5	4S	P232	9	9P	R112	5	1A	V900	8	1K
J12	5	1A	P233	9	4P	R134	4	4L			
			P234	9	7P	R301	4	10A			
LR1513	8	5L	P251	10	7N	R302	4	9A	W10	4	2G
LR1514	8	5L	P411	12	3A	R304	4	10A	W11	4	7G
			P411	7	1A	R311	4	9A	W651	3	9N
			P411	7	1P	R351	5	4B	W900	8	3H
P10	4	2G	P511	12	5A	R352	5	4B	W900	8	6L
P11	4	7G	P511	2	2N	R975	8	2A	W900	8	7H
P105	4	7P	P511	2	4A	R976	8	5A	W901	8	5H
P106	6	9A	P511	2	5N	R977	8	5A	W902	8	2H
P107	5	6S	P512	12	5J	R3007	3	5M	W903	8	4H
P108	5	4S	P512	1	10N	R300B	3	2M	W916	6	2N
P120	4	4M	P512	2	1A	R3009	3	4M			
P120	4	4M	P512	2	1N	R3010	3	7M			
P120	5	4B									

OTHER PARTS

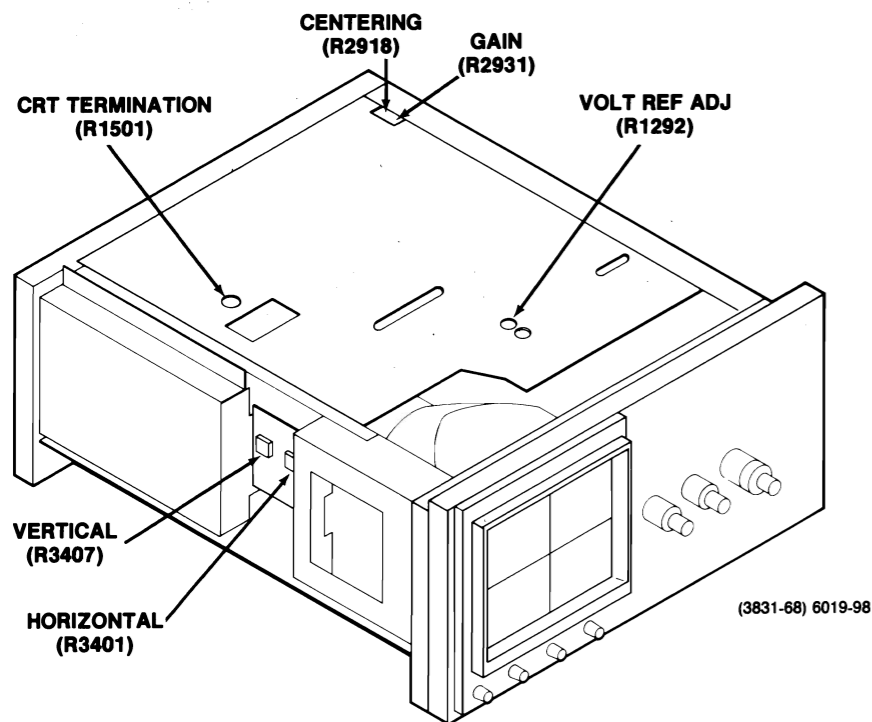

(3831-68) 6019-98

A13—CRT TERMINATION, A14—DYNAMIC CENTERING, and A2—REGULATOR, ADJUSTMENT LOCATIONS 1

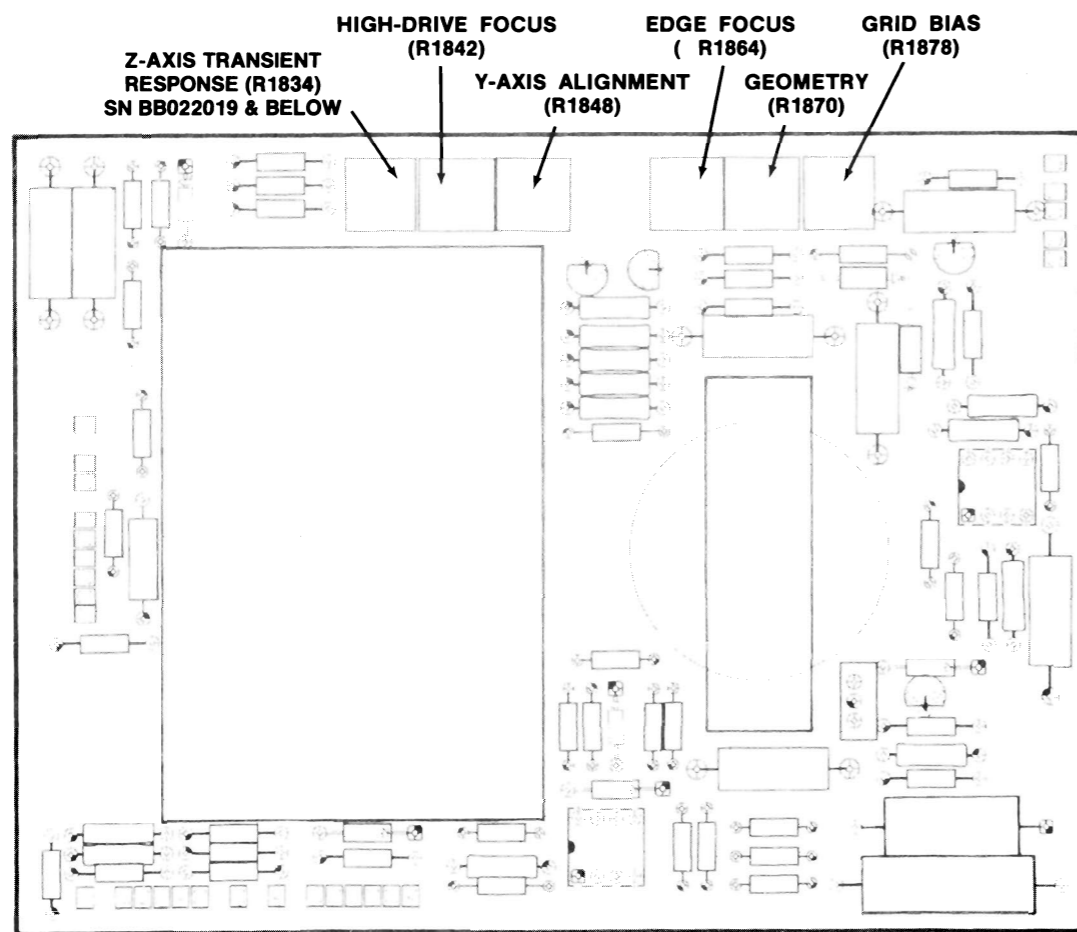

(3831-69A) 6017-22

A9—HIGH VOLTAGE, ADJUSTMENT LOCATIONS 2

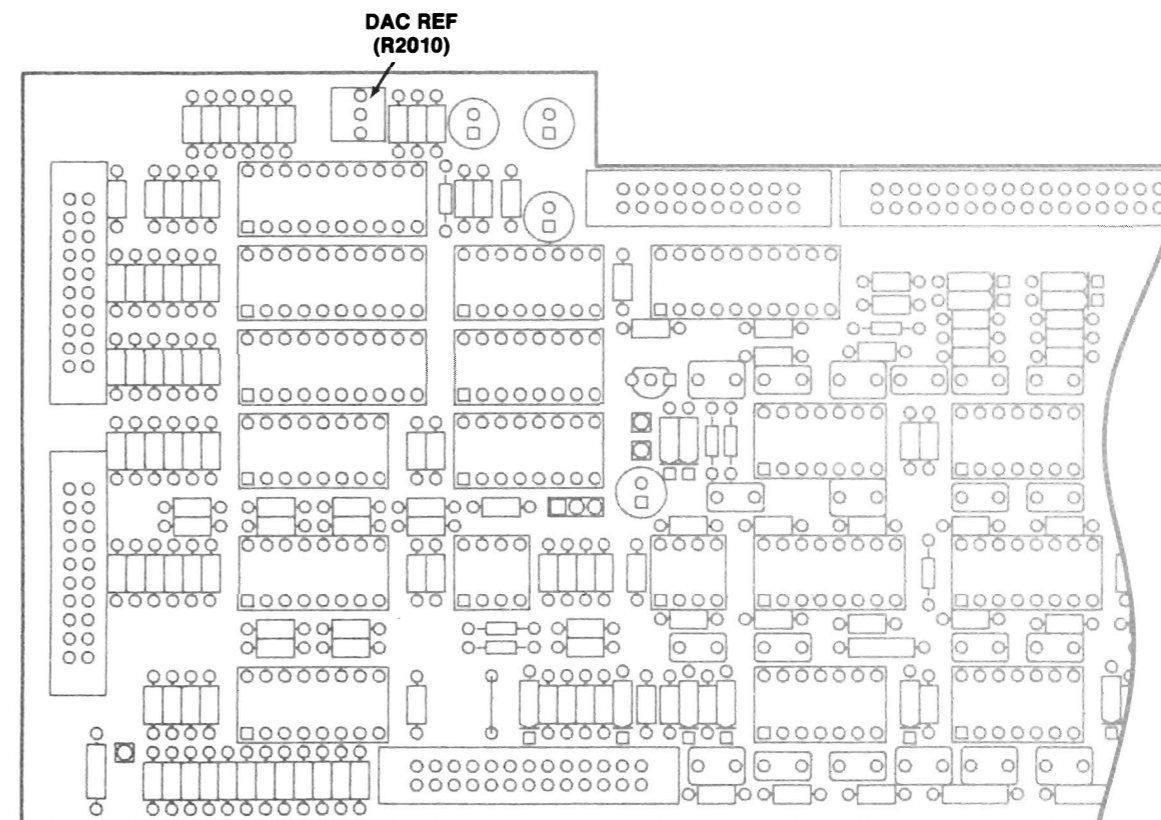

(6019-96) 6017-23

A5—CONTROL, ADJUSTMENT LOCATIONS 3

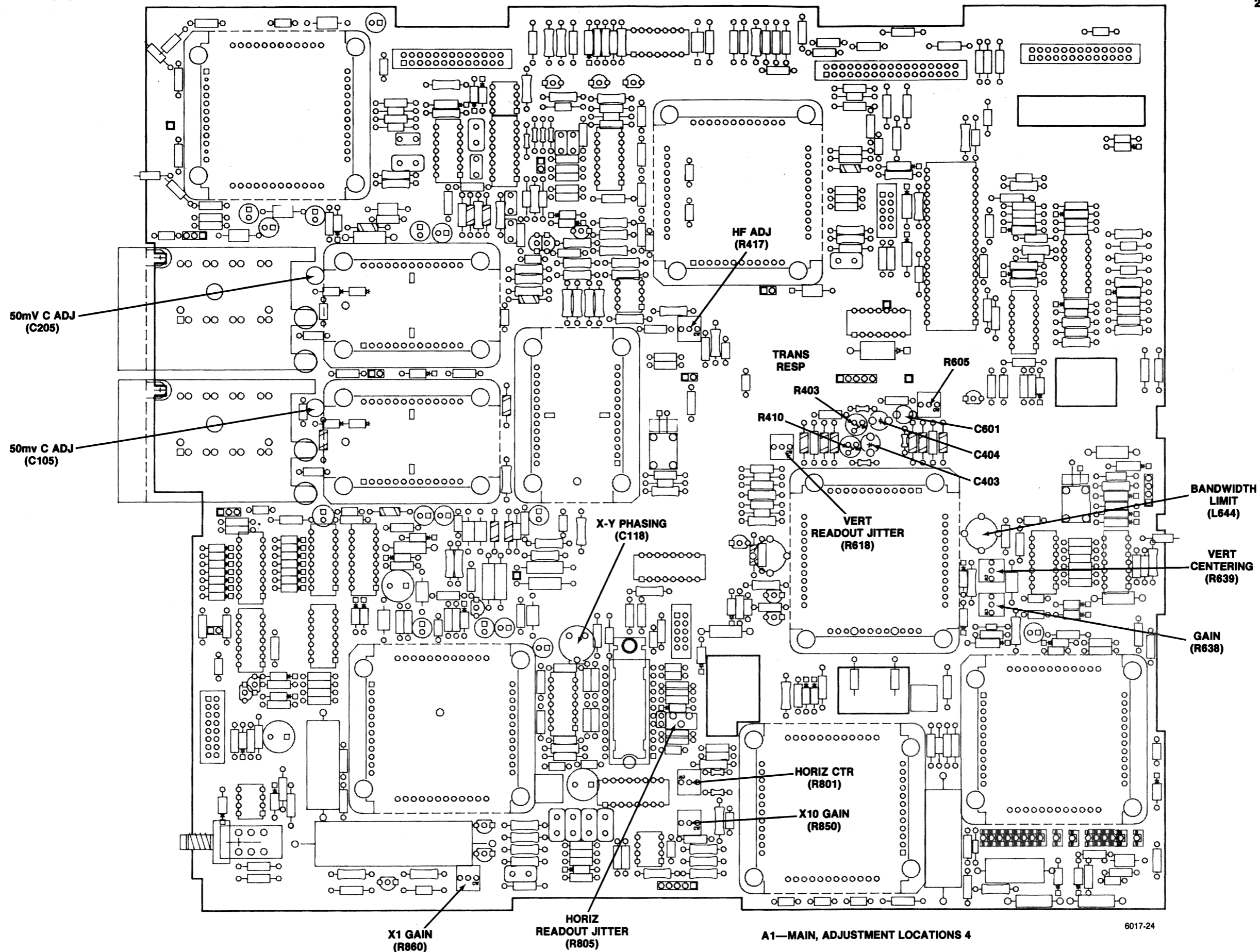

A1—MAIN, ADJUSTMENT LOCATIONS 4

ACRONYM DICTIONARY

The following listing explains some of the less obvious acronyms and signal labels used on the schematics. Acronyms and labels not shown in this listing may be included in the circuit descriptions (Section 3) and should be obvious if thought is given to the intended circuit function.

+CH1 SIG—+CH4 SIG...positive preamp output signals	CLK...clock	RO DO...readout data out
+HORIZ SIG...positive horizontal output signal	CNTR RESET...counter reset	ROI...readout intensity
+VERT SIG...positive vertical output signal	COL 0—COL 4...column 0—column 4...switch matrix columns 0—4	ROIR...readout intensity revised
—CH1 SIG——CH4 SIG...negative preamp output signals	CONT DATA...control data	ROSFRAME...readout subframe
—HORIZ SIG...negative horizontal output signal	CTC...capacitor, timing compensation	ROW 0—ROW 9...switch matrix rows 0—9
—VERT SIG...negative vertical output signal	D0—D7...data bits 0—7	SEC/DIV VAR...SEC/DIV variable
A SWP CLK...A sweep clock	DAC LSB CLK...DAC least significant data bits clock	SSA...A selected signal source
A TIM REF...A timing reference	DAC MSB CLK...DAC most significant data bits clock	TRACE SEP...trace separation
A TRIG CLK...A trigger clock	DAC MUX1 IN...DAC multiplexer 1 input	TRIG LED...trigger LED
A TRIG LVL...A trigger level	DAC MUX0 INH...DAC multiplexer 0 inhibit	TRIG LEVEL...trigger level
A0—A15...address bits 0—15	DAC MUX1 INH...DAC multiplexer 1 inhibit	TRIG STAT STRB...trigger status strobe
AHO...A holdoff	DAC MUX2 INH...DAC multiplexer 2 inhibit	TS1+TS2...trace separation 1 and 2
ATTN CLK...attenuator clock	DAC MUX1 A0...DAC multiplexer 1, address bit 0	TSO...trigger status output
ATTN STRB...attenuator strobe	DAC MUX1 A1...DAC multiplexer 1, address bit 1	TXY...triggered X-Y
B SWP CLK...B sweep clock	DAC MUX1 A2...DAC multiplexer 1, address bit 2	VAR OCT...variable octopole (geometry)
B TIM REF...B timing reference	DAC MUX1 IN...DAC multiplexer 1 input	VMA...valid memory address
B TRIG CLK...B trigger clock	·DD0—DD7...dot data bits 0—7	VQ OUT...variable quadrapole output
B TRIG LVL...B trigger level	DI...display intensity	VZ OUT...variable Z-axis output
B1—B12...DAC input bits 1—12	DIR...display intensity revised	<u>A</u> AUXTRIG ...A auxiliary trigger
BD0—BD7...buffered data bits 0—7	DISP SEQ CLK...display sequencer clock	<u>B</u> AUXTRIG ...B auxiliary trigger
BDCA...bypass delay comparator A	DLY A...delay A	<u>BWL</u> ...bandwidth limit
BDCB...bypass delay comparator B	DLY B...delay B	<u>DS</u> ...delay select
BDTL...B delayed trigger level selector	DLY REF 0...delay reference 0	<u>E</u> ...enable
BHO...B holdoff	DLY REF 1...delay reference 1	<u>HSA</u> ...horizontal select A
BWL B...bandwidth limited B signal	DOTOK...dot ok	<u>HSB</u> ...horizontal select B
BYP...bypass	FB...feedback	<u>MAG</u> ...magnify
CA0—CA6...character address bits 0—7	HORIZ OUT...channel 1 output to horizontal in X-Y	<u>RDA</u> ...reset delay adjust
CD1—CD6...character data bits 1—7	HORIZ POS...horizontal position	<u>ROA</u> ...readout acknowledge
CH1 OVL...channel 1 overload	HORIZ VAR...horizontal variable	<u>ROB</u> ...readout blank
CH1 PA CLK...CH1 preamp clock	LED CLK...LED clock	<u>ROR</u> ...readout request
CH1 POS...channel 1 position	LED DATA...front panel LED data	<u>ROS 1</u> ...readout strobe 1
CH1 PRB...channel 1 probe	LINE TRIG...60 Hz line trigger	<u>ROS 2</u> ...readout strobe 2
CH1 TRIG PICKOFF...channel 1 trigger pickoff	LINE UP...ac power is above minimum	<u>SGAZ</u> ...sweep gate A to Z axis
CH1 VAR...channel 1 variable	MR...memory ready	<u>SGA</u> ...sweep gate A
CH2 APO+...channel 2 auxiliary pickoff, noninverting	PORT1 CLK...port 1 clock	<u>SGBZ</u> ...sweep gate B to Z axis
CH2 OVL...channel 2 overload	PORT2 CLK...port 2 clock	<u>SGB</u> ...sweep gate B
CH2 PA CLK...channel 2 preamp clock	PORT3 INH...port 3 inhibit	<u>TSA</u> ...trigger status A
CH2 POS...channel 2 position	PWR DOWN...power down	<u>TSB</u> ...trigger status B
CH2 PRB...channel 2 probe	PWR UP...power up	<u>VS1—VS4</u> ...vertical selects 1—4
CH2 TRIG PICKOFF...channel 2 trigger pickoff	QP1+...quad pole 1 plus	
CH2 VAR...channel 2 variable	QP2+...quad pole 2 plus	
CH3 PRB...channel 3 probe	R/ <u>W</u> ...read/write	
CH3 TRIG PICKOFF...channel 3 trigger pickoff	R/ <u>W</u> DLY'D...read/write delayed	
CH4 POS...channel 4 position	R/ <u>W</u> DLYD...read/write delayed	
CH4 PRB...channel 4 probe	READOUT HORIZ OUT...readout horizontal output	
CH4 TRIG PICKOFF...channel 4 trigger pickoff	READOUT VERT OUT...readout vertical output	

REPLACEABLE MECHANICAL PARTS

PARTS ORDERING INFORMATION

Replacement parts are available from or through your local Tektronix, Inc. Field Office or representative.

Changes to Tektronix instruments are sometimes made to accommodate improved components as they become available, and to give you the benefit of the latest circuit improvements developed in our engineering department. It is therefore important, when ordering parts, to include the following information in your order: Part number, instrument type or number, serial number, and modification number if applicable.

If a part you have ordered has been replaced with a new or improved part, your local Tektronix, Inc. Field Office or representative will contact you concerning any change in part number.

Change information, if any, is located at the rear of this manual.

ITEM NAME

In the Parts List, an Item Name is separated from the description by a colon (:). Because of space limitations, an Item Name may sometimes appear as incomplete. For further Item Name identification, the U.S. Federal Cataloging Handbook H6-1 can be utilized where possible.

FIGURE AND INDEX NUMBERS

Items in this section are referenced by figure and index numbers to the illustrations.

INDENTATION SYSTEM

This mechanical parts list is indented to indicate item relationships. Following is an example of the indentation system used in the description column.

```

1 2 3 4 5           Name & Description
Assembly and/or Component
Attaching parts for Assembly and/or Component
    **** END ATTACHING PARTS ****
Detail Part of Assembly and/or Component
Attaching parts for Detail Part
    **** END ATTACHING PARTS ****
Parts of Detail Part
Attaching parts for Parts of Detail Part
    **** END ATTACHING PARTS ****
    
```

Attaching Parts always appear in the same indentation as the item it mounts, while the detail parts are indented to the right. Indented items are part of, and included with, the next higher indentation.

Attaching parts must be purchased separately, unless otherwise specified.

ABBREVIATIONS

#	INCH	ELCTRN	ELECTRON	IN	INCH	SE	SINGLE END
ACTR	NUMBER SIZE	ELEC	ELECTRICAL	INCAND	INCANDESCENT	SECT	SECTION
ADPTR	ACTUATOR	ELCTLT	ELECTROLYTIC	INSUL	INSULATOR	SEMICOND	SEMICONDUCTOR
ALIGN	ADAPTER	ELEM	ELEMENT	INTL	INTERNAL	SHLD	SHIELD
AL	ALIGNMENT	EPL	ELECTRICAL PARTS LIST	LPHLDR	LAMPHOLDER	SHLDR	SHOULDERED
ALUM	ALUMINUM	EQPT	EQUIPMENT	MACH	MACHINE	SKT	SOCKET
ASSEM	ASSEMBLED	EXT	EXTERNAL	MECH	MECHANICAL	SL	SLIDE
ASSY	ASSEMBLY	FIL	FILLISTER HEAD	MTG	MOUNTING	SLFLKG	SELF-LOCKING
ATTEN	ATTENUATOR	FLEX	FLEXIBLE	NIP	NIPPLE	SLVG	SLEEVEING
AWG	AMERICAN WIRE GAGE	FLH	FLAT HEAD	NON WIRE	NOT WIRE WOUND	SPR	SPRING
BD	BOARD	FLTR	FILTER	OB	ORDER BY DESCRIPTION	SQ	SQUARE
BRKT	BRACKET	FR	FRAME or FRONT	OD	OUTSIDE DIAMETER	SST	STAINLESS STEEL
BRS	BRASS	FSTNR	FASTENER	OVH	OVAL HEAD	STL	STEEL
BRZ	BRONZE	FT	FOOT	PH BRZ	PHOSPHOR BRONZE	SW	SWITCH
BSHG	BUSHING	FXD	FIXED	PL	PLAIN or PLATE	T	TUBE
CAB	CABINET	GSKT	GASKET	PLSTC	PLASTIC	TERM	TERMINAL
CAP	CAPACITOR	HDL	HANDLE	PN	PART NUMBER	THD	THREAD
CER	CERAMIC	HEX	HEXAGON	PNH	PAN HEAD	THK	THICK
CHAS	CHASSIS	HEX HD	HEXAGONAL HEAD	PWR	POWER	TNSN	TENSION
CKT	CIRCUIT	HEX SOC	HEXAGONAL SOCKET	RCPT	RECEPTACLE	TPG	TAPPING
COMP	COMPOSITION	HLCPS	HELICAL COMPRESSION	RES	RESISTOR	TRH	TRUSS HEAD
CONN	CONNECTOR	HLEXT	HELICAL EXTENSION	RGD	RIGID	V	VOLTAGE
COV	COVER	HV	HIGH VOLTAGE	RLF	RELIEF	VAR	VARIABLE
CPLG	COUPLING	IC	INTEGRATED CIRCUIT	RTNR	RETAINER	W/	WITH
CRT	CATHODE RAY TUBE	ID	INSIDE DIAMETER	SCH	SOCKET HEAD	WSHR	WASHER
DEG	DEGREE	IDNT	IDENTIFICATION	SCOPE	OSCILLOSCOPE	XFMR	TRANSFORMER
DWR	DRAWER	IMPLR	IMPELLER	SCR	SCREW	XSTR	TRANSISTOR

CROSS INDEX - MFR. CODE NUMBER TO MANUFACTURER

Mfr. Code	Manufacturer	Address	City, State, Zip Code
01536	TEXTRON INC CAMCAR DIV	1818 CHRISTINA ST	ROCKFORD IL 61108
05006	SEMS PRODUCTS UNIT	3628 CRENSHAM BLVO	LOS ANGELES CA 90015
06915	20TH CENTURY PLASTICS INC	5825 N TRIPP AVE	CHICAGO IL 60646
09772	RICHCO PLASTIC CO	16730 E JOHNSON DRIVE	CITY OF INDUSTRY CA 91744
09922	WEST COAST LOCKMASHER CO INC	P O BOX 3588	
09922	BURNOY CORP	RICHARDS AVE	NORMALK CT 06852
12327	FREEMAY CORP	9301 ALLEN DR	CLEVELAND OH 44125
16428	BELDEN CORP	2200 US HWY 27 SOUTH	RICHMOND IN 47374
	ELECTRONIC DIV	P O BOX 1980	
22526	DU PONT E I DE NEMOURS AND CO INC	30 HUNTER LANE	CAMP HILL PA 17011
	DU PONT CONNECTOR SYSTEMS		
24931	SPECIALTY CONNECTOR CO INC	2620 ENDRESS PLACE	GREENWOOD IN 46142
		P O BOX D	
31918	ITT SCHADOM INC	8081 MALLACE RO	EDEN PRAIRIE MN 55343
50293	GENERAL ELECTRIC CO		
	ENGINEERING DEPT		
54583	TDK ELECTRONICS CORP	755 EASTGATE BLVD	GARDEN CITY NY 11530
55285	BERGQUIST CO INC THE	5300 EDINA INDUSTRIAL BLVO	MINNEAPOLIS MN 55435
70903	BELDEN CORP	2000 S BATAVIA AVE	GENEVA IL 60134
71400	BUSSMANN MFG CO	114 OLD STATE RO	ST LOUIS MO 63178
	MCGRAW EDISION CO	PO BOX 14460	
73743	FISCHER SPECIAL MFG CO	446 MORGAN ST	CINCINNATI OH 45206
78189	ILLINOIS TOOL WORKS INC	ST CHARLES ROAD	ELGIN IL 60120
	SHAKEPROOF DIVISION		
80009	TEKTRONIX INC	4900 S W GRIFFITH DR	BEAVERTON OR 97077
		P O BOX 500	
80033	MICRODOT MANUFACTURING INC	1345 MIAMI ST	TOLEDO OH 43605
	PRESTOLE EVERLOCK DIV	P O BOX 278	
83385	MICRODOT MANUFACTURING INC	3221 W BIG BEAVER RD	TROY MI 48098
	GREER-CENTRAL DIV		
83486	ELCO INDUSTRIES INC	1101 SAMUELSON RD	ROCKFORD IL 61101
85480	BRADY M H CO	727 W GLENDALE AVE	MILWAUKEE WI 53209
86928	SEASTROM MFG CO INC	701 SONORA AVE	GLENDALE CA 91201
91260	CONNOR SPRING AND MFG CO	1729 JUNCTION AVE	SAN JOSE CA 95112
93907	TEXTRON INC	600 18TH AVE	ROCKFORD IL 61101
	CAMCAR DIV		
95987	MECKESSER CO INC	4444 WEST IRVING PARK RD	CHICAGO IL 60641
53109	FELLER ASA AODLF AG	355 TESCONI CIRCLE	SANTA ROSA CA 95401
	C/O PANEL COMPONENTS CORP		
53629	SCHURTER AG H	2015 SECOND STREET	BERKELEY CA 94170
	C/O PANEL COMPONENTS CORP		
TK0435	LEMIS SCREM CO	4114 S PEORIA	CHICAGO IL 60609
TK0861	H SCHURTER AG OIST PANEL COMPONENTS	2015 SECOND STREET	BERKELEY CA 94170
TK1285	GEROME MFG CO INC	PO BOX 737	NEUBURG OR 97132
TK1328	NIDEC AMERICA CORP	682 TRANSFER RD	ST PAUL MN 55114
TK1373	PATELEC-CEM (ITALY)	10156 TORINO	VAICENTALLO 62/455 ITALY
TK1634	SCHRAMM PLASTICS	8770 SW BURNHAM	TIGARD OR 97223

2445A Replaceable Mechanical Parts
2445A/2455A Service

Fig. & Index No.	Tektronix Part No.	Serial/Assembly No.		Qty	12345 Name & Description	Mfr. Code	Mfr. Part No.	
		Effective	Discont					
1-1	334-6338-00			1	MARKER,IDENT:MKO TEKTRONIX 2445A	80009	334-6338-00	
-2	366-2041-03			4	KNOB:DOVE GRAY,8AR,0.172 X 0.41 X 0.496	80009	366-2041-03	
	377-0512-01			4	INSERT,KNOB:0.172 IO X 0.28 OD X 0.64,NYL	80009	377-0512-01	
	366-2036-00			1	PUSH BUTTON:GY,0.206 SQ,1.445 H	80009	366-2036-00	
-3	334-6335-00			1	MARKER,IDENT:MKO CRT CONTROLS	80009	334-6335-00	
-4	200-2779-00			1	COVER, TOP:TRIM	80009	200-2779-00	
-5	348-0740-00			2	FOOT,CABINET:BOTTOM FRONT,PLASTIC ATTACHING PARTS	80009	348-0740-00	
-6	211-0718-00			2	SCREW,MACHINE:6-32 X 0.312,FLH,100 DEG,STL END ATTACHING PARTS	83486	ORDER BY OESCR	
-7	101-0082-02			1	TRIM,DECORATIVE:FRONT,PLASTIC ATTACHING PARTS	80009	101-0082-02	
-8	211-0718-00			10	SCREW,MACHINE:6-32 X 0.312,FLH,100 DEG,STL	83486	ORDER BY OESCR	
	214-3374-01			1	SPRING,FILTER:1.32 L,CU-8E END ATTACHING PARTS	80009	214-3374-01	
-9	337-2926-03			1	SHLD,IMPLOSION:4.44 X 3.67 X 0.06,CLEAR	80009	337-2926-03	
	378-0199-03			1	FILTER,LT,CRT:BLUE,3.415 X 4.105 X 0.030 TH K,ACRYLIC PLEXIGLAS	TK1634	378019903	
-10	334-4378-01			1	MARKER,IDENT:MKO PROBE POWER	80009	334-4378-01	
-11	334-4381-02			1	MARKER,IDENT:MKO CONNECTOR IDENT	80009	334-4381-02	
-12	334-4377-04			1	MARKER,IDENT:MKO CAUTION	80009	334-4377-04	
-13	348-0729-00			2	FOOT,CABINET:W/CORD WRAP,REAR,BLACK PU ATTACHING PARTS	80009	348-0729-00	
-14	212-0154-00			4	SCREW,MACHINE:8-32 X 1.125,PNH,STL	83385	ORDER BY OESCR	
	211-0722-00			2	SCREW,MACHINE:6-32 X 0.25,PNH,STL END ATTACHING PARTS	80009	211-0722-00	
-15	200-2685-02			1	COVER,REAR:POLYCARBONATE	80009	200-2685-02	
-16	334-6339-00			1	MARKER,IDENT:MKO 2445A	80009	334-6339-00	
-17	367-0303-04			1	HANDLE,CARRYING:12.86 L,GRIP & INDEX ATTACHING PARTS	80009	367-0303-04	
-18	212-0144-00			2	SCREW,TPG,TF:8-16 X 0.562,PLASTITE,SPCL HD END ATTACHING PARTS	93907	225-38131-012	
-19	437-0286-03			1	CABINET,SCOPE:ALUMINUM	80009	437-0286-03	
	348-0764-03			1	SHLD GSKT,ELEK:0.125X0.188,MIRE MESH,34.0 L	80009	348-0764-03	

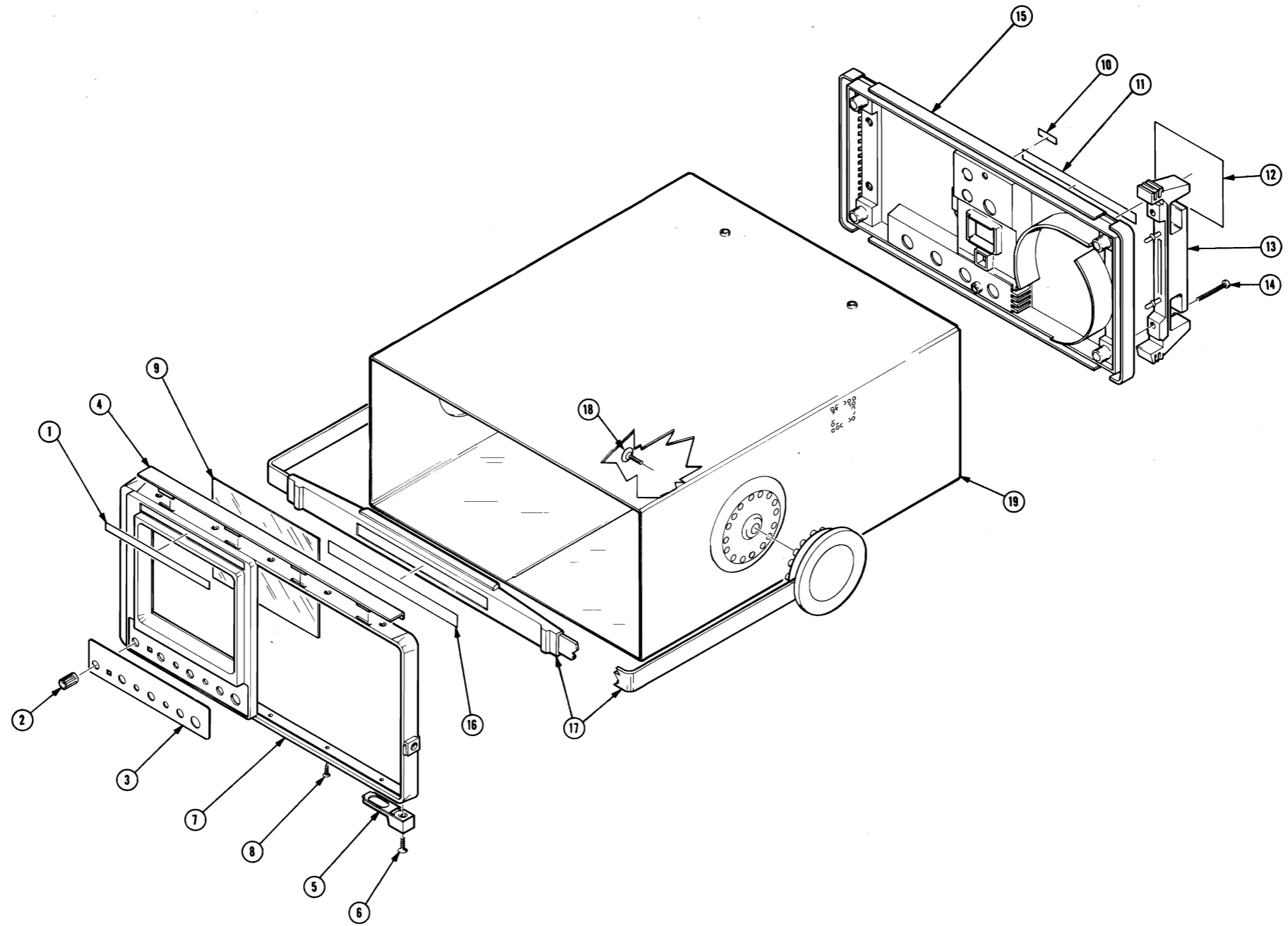

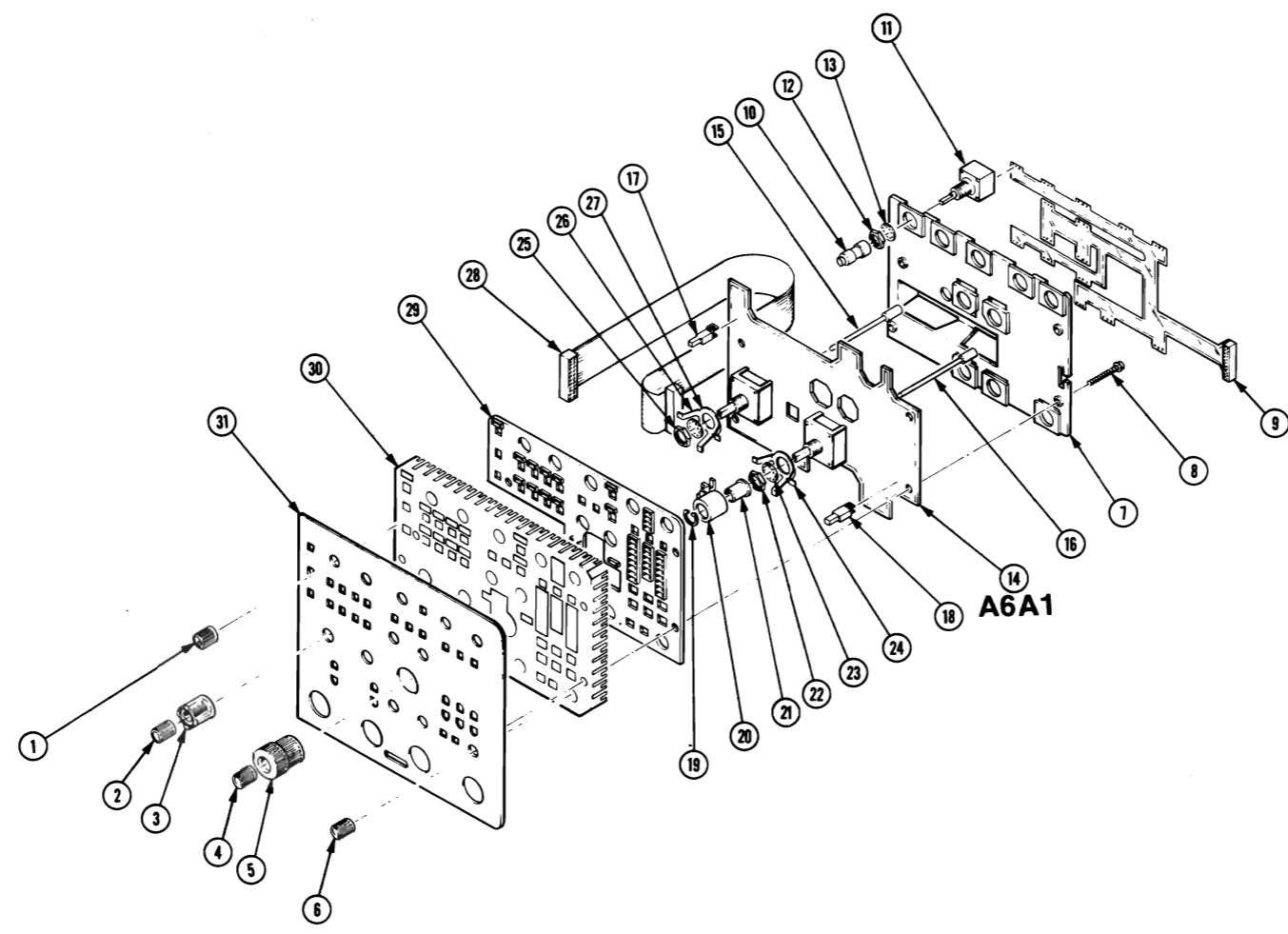

2445A Replaceable Mechanical Parts
2445A/2455A Service

Fig. & Index No.	Tektronix Part No.	Serial/Assembly No. Effective Dscont	Qty	12345	Name & Description	Mfr. Code	Mfr. Part No.
2-1	366-2041-03		7		KNOB:DOVE GRAY,BAR,0.172 X 0.41 X 0.496	80009	366-2041-03
-2	366-1510-00		2		KNOB:DOVE GRAY,VAR,0.127 X 0.392 X 0.466	80009	366-1510-00
-3	366-1227-00		2		KNOB:DOVE GY,VOLTS/OIV,0.486 X 0.706 X 0.6	80009	366-1227-00
-4	366-1510-00		1		KNOB:DOVE GRAY,VAR,0.127 X 0.392 X 0.466	80009	366-1510-00
-5	366-1220-01		1		KNOB:DOVE GY,TIME/DIV,0.65 X 0.855 X 0.8	80009	366-1220-01
-6	366-1833-01		3		KNOB:DOVE GRAY,0.25 IO X 0.392 00 X 0.466 H	80009	366-1833-01
-7	352-0790-00	8010100	1	8010164	HLDR,VAR RES:BLACK POLYCARBONATE	80009	352-0790-00
	352-0790-01	8010165	1		HLDR,VAR,RES:BLACK POLYCARBONATE ATTACHING PARTS	80009	352-0790-01
-8	211-0302-00		4		SCR,ASSEM MSHR:4-40 X 0.75,PNH,STL,TORX DR END ATTACHING PARTS	01536	ORDER BY DESCR
-9	259-0025-00		1		FLEX CIRCUIT:POLYMIQE	80009	259-0025-00
-10	377-0413-00		10		INSERT,KNOB:0.055 IO X 0.37 00 X 0.821,PM	80009	377-0413-00
-11	-----		13		RES,VAR,NONMM:(SEE A6R3007 THRU R3019 REPL) ATTACHING PARTS		
-12	220-0495-00		13		NUT,PLAIN,HEX:0.375-32 X 0.438 HEX,BRS	73743	ORDER BY OESCR
-13	210-0012-00		13		WASHER,LOCK:0.384 ID,INTL,0.022 THK,STL END ATTACHING PARTS	09772	ORDER BY OESCR
-14	-----		1		CIRCUIT BO ASSY:FRONT PANEL(SEE A6A1 REPL)		
-15	384-1684-01		2		.SHAFT,VARIABLE:2.16 L,POLYCARBONATE	80009	384-1684-01
-16	384-1683-01		1		.SHAFT,VARIABLE:2.36 L,POLYCARBONATE	80009	384-1683-01
-17	366-1516-00		20		.PUSH BUTTON:IVORY GRAY,0.3 X 0.665 H,SQ	80009	366-1516-00
-18	366-1538-00		10		.PUSH BUTTON:IVORY GY,0.3 X 0.665,RND	80009	366-1538-00
-19	354-0669-00		1		.RING,RETAINING:CRESENT,0.438 00	80009	354-0669-00
-20	214-3824-01		1		.ACTUATOR,SWITCH:TIME PER OIV	80009	214-3824-01
-21	377-0412-01		1		.INSERT,KNOB:0.182 X 0.5 X 0.393,POLY	80009	377-0412-01
-22	220-0495-00		1		.NUT,PLAIN,HEX:0.375-32 X 0.438 HEX,BRS	73743	ORDER BY OESCR
-23	210-0012-00		1		.WASHER,LOCK:0.384 ID,INTL,0.022 THK,STL	09772	ORDER BY OESCR
-24	214-3373-00		1		.SPRING,GROUND:PHOSPHOR-BRONZE	80009	214-3373-00
-25	220-0495-00		2		.NUT,PLAIN,HEX:0.375-32 X 0.438 HEX,BRS	73743	ORDER BY OESCR
-26	210-0012-00		2		.WASHER,LOCK:0.384 ID,INTL,0.022 THK,STL	09772	ORDER BY OESCR
-27	214-3373-00		2		.SPRING,GROUND:PHOSPHOR-BRONZE	80009	214-3373-00
-28	175-9916-00		1		.CA ASSY,SP,ELEC:20,28 AWG,11.0 L	80009	175-9916-00
-29	351-0750-00		1		GUIOE,SWITCH:ABS,BLACK	80009	351-0750-00
-30	354-0655-00		1		RING,MOUNTING:FR PNL,4.16 X 6.065,BRASS	80009	354-0655-00
-31	333-3274-00		1		PANEL,FRONT:	80009	333-3274-00

2445A Replaceable Mechanical Parts
2445A/2455A Service

Fig. & Index No.	Tektronix Part No.	Serial/Assembly No. Effective Dscont	Qty	12345 Name & Description	Mfr. Code	Mfr. Part No.
3-1	407-2790-02		1	BRACKET,CKT B0:VERTICAL,ALUMINUM ATTACHING PARTS	80009	407-2790-02
-2	211-0711-00		4	SCR,ASSEM MSHR:6-32 X 0.25,PNH,STL,TORX	01536	ORDER BY OESCR
-3	211-0722-00		2	SCREM,MACHINE:6-32 X 0.25,PNH,STL END ATTACHING PARTS	80009	211-0722-00
-4	343-1012-00		2	RETAINER,CKT B0:POLYCARBONATE	80009	343-1012-00
-5	426-1864-01		1	FRAME,CRT: ATTACHING PARTS	80009	426-1864-01
-6	211-0713-00		4	SCREM,MACHINE:6-32 X 1.25,FLH,100 DEG,STL	83385	ORDER BY OESCR
-7	213-0978-00		6	SCREM,TPG,TR:6-32 X 0.5,FLH,100DEG,STL END ATTACHING PARTS	80009	213-0978-00
-8	343-0992-00		2	RETAINER,CRT:CLEAR,PLASTIC (UPPER RT/LOWER LEFT/NAT)	80009	343-0992-00
-9	343-0993-00		2	RETAINER,CRT:BLACK,PLASTIC (UPPER LEFT/LOWER RT/BLK)	80009	343-0993-00
-10	348-0731-01		1	GASKET:CRT,POLYETHYLENE	80009	348-0731-01
-11	378-0204-00		1	REFLECTOR,LIGHT:INT SCALE ILLUMINATION	80009	378-0204-00
-12	-----		1	CKT BOARD ASSY:SCALE ILLUM (SEE A8 REPL)		
-13	386-4728-01		1	SUBPANEL,FRONT:	80009	386-4728-01
-14	348-0792-01		1	GASKET:ELECTRICAL SHIELD,34.0 L	80009	348-0792-01
-15	175-4593-01		1	CA ASSY,SP,ELEC:2,22 AWG,3.5 L,RIBBON	80009	175-4593-01
-16	386-4713-02		1	PLATE,REAR:POWER SUPPLY ATTACHING PARTS	80009	386-4713-02
-17	211-0711-00		5	SCR,ASSEM MSHR:6-32 X 0.25,PNH,STL,TORX END ATTACHING PARTS	01536	ORDER BY OESCR
	337-3059-00		1	SHIELD,ELEC:LVPS	80009	337-3059-00
	343-1099-01		1	RTNR,POWER SPLY:LDM VOLTAGE,FRONT,PC	80009	343-1099-01
	334-3379-00		1	MARKER,IDENT:MARKED GROUND SYMBOL	80009	334-3379-00
-18	195-3984-00		1	LEAD,ELECTRICAL:22 AWG,4.0 L,8-01	80009	195-3984-00
-19	334-6652-00		1	MARKER,IDENT:MKO CAUTION BATTERY	80009	334-6652-00
-20	211-0304-00		2	SCR,ASSEM MSHR:4-40 X 0.312,PNH,STL,T9	01536	ORDER BY OESCR
-21	386-4863-00		1	SUPPORT,CKT B0:	80009	386-4863-00
-22	378-0275-00		1	DEFLECTOR,AIR:ALUMINUM ATTACHING PARTS	80009	378-0275-00
-23	211-0711-00		1	SCR,ASSEM MSHR:6-32 X 0.25,PNH,STL,TORX END ATTACHING PARTS	01536	ORDER BY OESCR
-24	119-2102-00		1	FAN,TUBEAXIAL:12V,1.5M,3200RPM,24CFM	TK1328	119-2102-00
-25	337-3021-01		1	SHIELD,ELEC:LVPS PEOPLE ATTACHING PARTS	80009	337-3021-01
-26	211-0711-00		2	SCR,ASSEM MSHR:6-32 X 0.25,PNH,STL,TORX END ATTACHING PARTS	01536	ORDER BY OESCR
-27	334-5196-00		1	MARKER,IDENT:MKO CAUTION (STANDARD,OPTIONS 05,06,09,10)	80009	334-5196-00
-28	200-2264-00		1	CAP,FUSEHOLDER:3AG FUSES	53629	FEK 031 1666
-29	204-0832-00		1	BODY,FUSEHOLDER:3AG & 5 X 20MM FUSES	TK0861	031 1673
-30	200-0237-04		1	COVER,FUHLR:PLASTIC	80009	200-0237-04
-31	195-3984-00		1	LEAD,ELECTRICAL:22 AWG,4.0 L,8-01	80009	195-3984-00
	195-3986-00		1	LEAD,ELECTRICAL:18 AWG,4.0 L,8-0 ATTACHING PARTS	80009	195-3986-00
-32	210-0457-00		1	NUT,PL,ASSEM MA:6-32 X 0.312,STL CD PL END ATTACHING PARTS (OPTION 11 PARTS INCLUOE:)	78189	511-061800-00
-33	175-6044-01		2	.CA ASSY,SP,ELEC:4,26 AWG,6.0 L,RIBBON . (TO A2J201,A2J202)	80009	175-6044-01
-34	210-0012-00		2	.WASHER,LDCK:0.384 ID,INTL,0.022 THK,STL	09772	ORDER BY OESCR
-35	210-0978-00		2	.WASHER,FLAT:0.375 ID X 0.5 00 X 0.024,STL	12327	ORDER BY OESCR
-36	386-5052-00		1	.PLATE,ADAPTER:PROBE POWER,ALUMINUM	80009	386-5052-00
	334-1529-01		1	.PLATE,IDENT:BLANK	80009	334-1529-01
-37	119-1536-00		1	FILTER,RFI:3A,250VAC,50/60HZ ATTACHING PARTS	54583	ZU82203-00
-38	211-0332-00		2	SCR,ASSEM MSHR:4-40 X 0.5,PNH,STL,T9	01536	ORDER BY OESCR
-39	210-0586-00		2	NUT,PL,ASSEM MA:4-40 X 0.25,STL CD PL END ATTACHING PARTS	78189	211-041800-00
-40	195-3989-00		1	LEAD,ELECTRICAL:18 AWG,4.0 L,8-9	80009	195-3989-00
-41	195-3990-00		1	LEAD,ELECTRICAL:18 AWG,4.5 L,5-4	80009	195-3990-00
-42	211-0304-00		2	SCR,ASSEM MSHR:4-40 X 0.312,PNH,STL,T9	01536	ORDER BY OESCR
-43	210-0586-00		2	NUT,PL,ASSEM MA:4-40 X 0.25,STL CD PL	78189	211-041800-00

Fig. & Index No.	Tektronix Part No.	Serial/Assembly No. Effective Dscont	Qty	12345 Name & Description	Mfr. Code	Mfr. Part No.
3-44	-----		1	SWITCH,SLIDE:DPOT (SEE S90 REPL)		
-45	195-3987-00		1	LEAD,ELECTRICAL:22 AWG,2.6 L,8-19	80009	195-3987-00
	195-3988-00		1	LEAD,ELECTRICAL:22 AWG,4.0 L,8-29	80009	195-3988-00
-46	-----		4	NUT,PLAIN,KNURL:(FURN WITH 131-1910-01 BNC)		
-47	-----		4	MASHER,LOCK:(FURN WITH 131-1910-01 BNC'S)		
-48	131-1910-01		4	CONN,RCPT,ELEC:BNC,FEMALE	24931	28JR284-1
-49	200-2686-00		1	COVER,REAR:CRT	80009	200-2686-00
				ATTACHING PARTS		
-50	211-0711-00		3	SCR,ASSEM MSHR:6-32 X 0.25,PNH,STL,TORX	01536	ORDER BY DESC
				END ATTACHING PARTS		
-51	195-8410-00		1	LEAD,ELECTRICAL:22 AWG,1.65 L	80009	195-8410-00
				ATTACHING PARTS		
-52	210-0551-00		1	NUT,PLAIN,HEX:4-40 X 0.25,ST CD PL	TK0435	ORDER BY DESC
				END ATTACHING PARTS		
-53	195-9513-00		1	LEAD,ELECTRICAL:22 AWG,1.4 L,	80009	195-9513-00
				ATTACHING PARTS		
-54	210-0551-00		1	NUT,PLAIN,HEX:4-40 X 0.25,ST CD PL	TK0435	ORDER BY DESC
				END ATTACHING PARTS		
-55	344-0250-00		1	RETAINER,CAP.:0.5 DIA,STEEL	80033	E50005-007
				ATTACHING PARTS		
-56	211-0747-00		1	SCREW,MACHINE:6-32 X 0.188,PNH,STL	80009	211-0747-00
				END ATTACHING PARTS		
-57	307-1154-00		1	PASSIVE NETWORK:CRT TERMINATOR	80009	307-1154-00
				ATTACHING PARTS		
-58	211-0304-00		2	SCR,ASSEM MSHR:4-40 X 0.312,PNH,STL,T9	01536	ORDER BY DESC
-59	210-0457-00		2	NUT,PL,ASSEM MA:6-32 X 0.312,STL CD PL	78189	511-061800-00
				END ATTACHING PARTS		
-60	407-2809-00		1	BRACKET,ANGLE:RESISTOR,AL	80009	407-2809-00
				ATTACHING PARTS		
-61	210-0583-00		2	NUT,PLAIN,HEX:0.25-32 X 0.312,BRS CO PL	73743	2X-20319-402
				END ATTACHING PARTS		
	334-1951-00		1	MARKER,IDENT:MKO WARNING,CRT VOLTAGES	80009	334-1951-00
-62	337-2931-01		1	SHIELD,CRT:	TK1285	337-2931-01
				ATTACHING PARTS		
-63	211-0337-00		4	SCREW,MACHINE:4-40 X 0.25,PNH,SST	01536	ORDER BY DESC
				END ATTACHING PARTS		
-64	200-0917-01		1	COVER,CRT SKT:2.052 OD X 0.291 H,PLASTIC	80009	200-0917-01
-65	-----		1	WIRE SET,ELEC:M/CRT SOCKET		
				(SEE A9M900 AND A9P900 REPL)		
-66	214-0291-00		2	CONTACT,ELEC:CRT CONNECTOR,CU BE SIL PL	80009	214-0291-00
				ATTACHING PARTS		
-67	211-0324-00		2	SCR,ASSEM MSHR:4-40 X 0.188,PNH,T9 TORX DR	01536	829-06780-024
-68	210-0586-00		2	NUT,PL,ASSEM MA:4-40 X 0.25,STL CD PL	78189	211-041800-00
				END ATTACHING PARTS		
-69	-----		1	COIL,TUBE OEFL:FXD,TRACE ROTATION		
				(SEE L90 REPL)		
-70	348-0762-00		1	GROMMET,PLASTIC:BLACK,ROUND,0.54 ID	80009	348-0762-00
-71	195-6851-01		1	LEAD,ELECTRICAL:BRAIDED,1.65 L	80009	195-6851-01
	195-8410-00		1	LEAD,ELECTRICAL:22 AWG,1.65 L	80009	195-8410-00
				ATTACHING PARTS		
-72	211-0337-00		2	SCREW,MACHINE:4-40 X 0.25,PNH,SST	01536	ORDER BY DESC
-73	210-0551-00		2	NUT,PLAIN,HEX:4-40 X 0.25,ST CD PL	TK0435	ORDER BY DESC
				END ATTACHING PARTS		
-74	-----		1	CKT BD ASSY:DYNAMIC CENTERING (SEE A14)		
				ATTACHING PARTS		
-75	361-0067-00		3	SPACER,CKT BD:0.187,NYLON	06915	LCB53M
				END ATTACHING PARTS		
-76	-----		5	.TERMINAL,PIN:0.365 L X 0.025 BRZ GLD PL		
				(SEE A124J141 REPL)		
-77	175-4596-00		1	CA ASSY,SP,ELEC:5,22 AWG,7.0 L,RIBBON	80009	175-4596-00
-78	348-0757-00		1	GROMMET,PLASTIC:BLACK,U SHAPE,0.25 ID	80009	348-0757-00
-79	343-0081-00		1	STRAP,RETAINING:0.125 DIA,NYLON	85480	CPNY-172BK
				ATTACHING PARTS		
-80	210-0457-00		1	NUT,PL,ASSEM MA:6-32 X 0.312,STL CD PL	78189	511-061800-00
				END ATTACHING PARTS		
-81	348-0763-00		1	GROMMET,PLASTIC:NATURAL,OVAL,1.235 ID	80009	348-0763-00
-82	348-0751-00		1	GROMMET,PLASTIC:NATURAL,3.11 X D.645 OBLONG	80009	348-0751-00

2445A Replaceable Mechanical Parts
 2445A/2455A Service

Fig. & Index No.	Tektronix Part No.	Serial/Assembly No. Effective Dscont	Qty	12345	Name & Description	Mfr. Code	Mfr. Part No.
3-83	343-1012-00		2		RETAINER,CKT BD:POLYCARBONATE	80009	343-1012-00
-84	441-1618-02		1		CHASSIS,SCOPE:	80009	441-1618-02

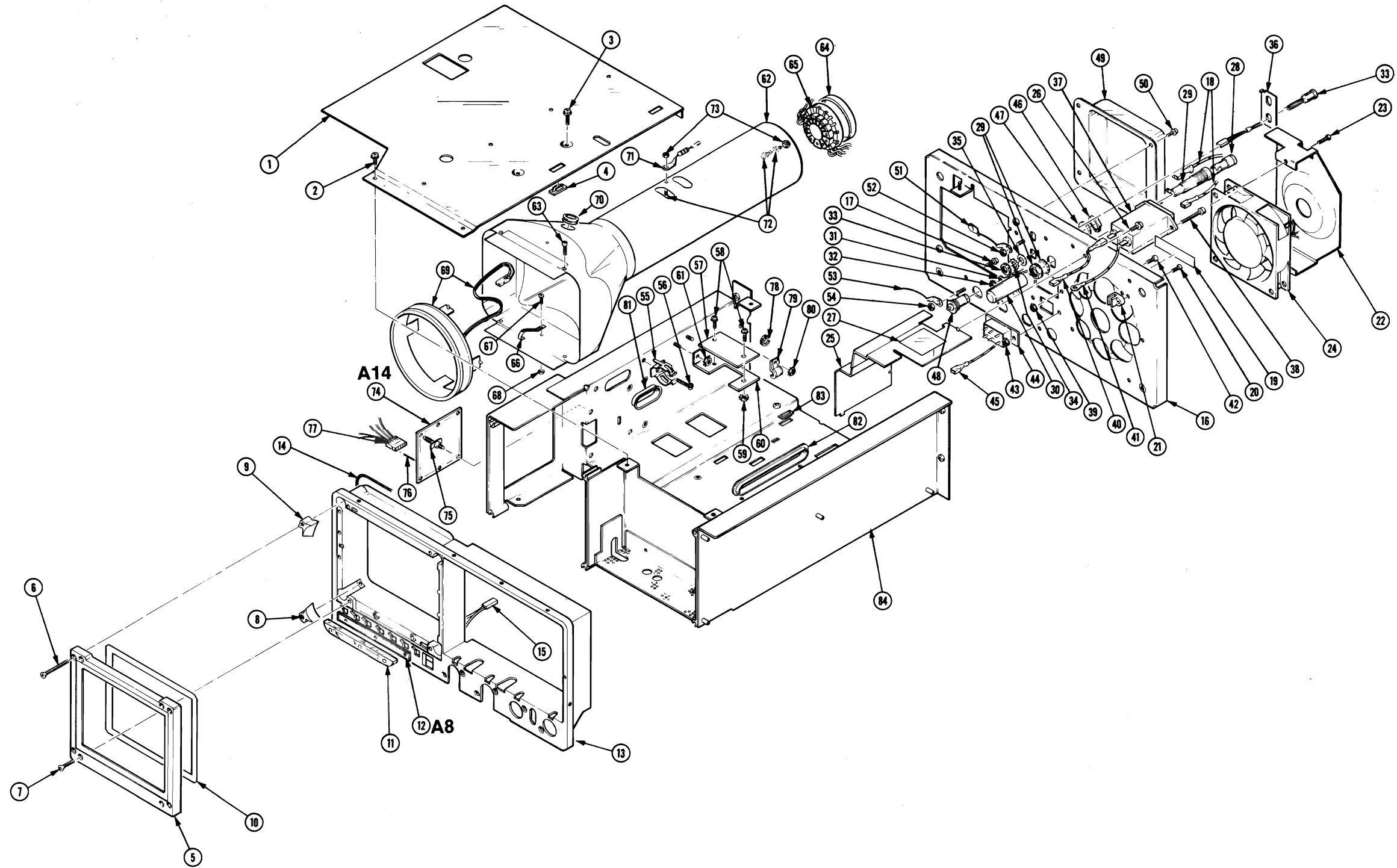

FIG. 3 CHASSIS

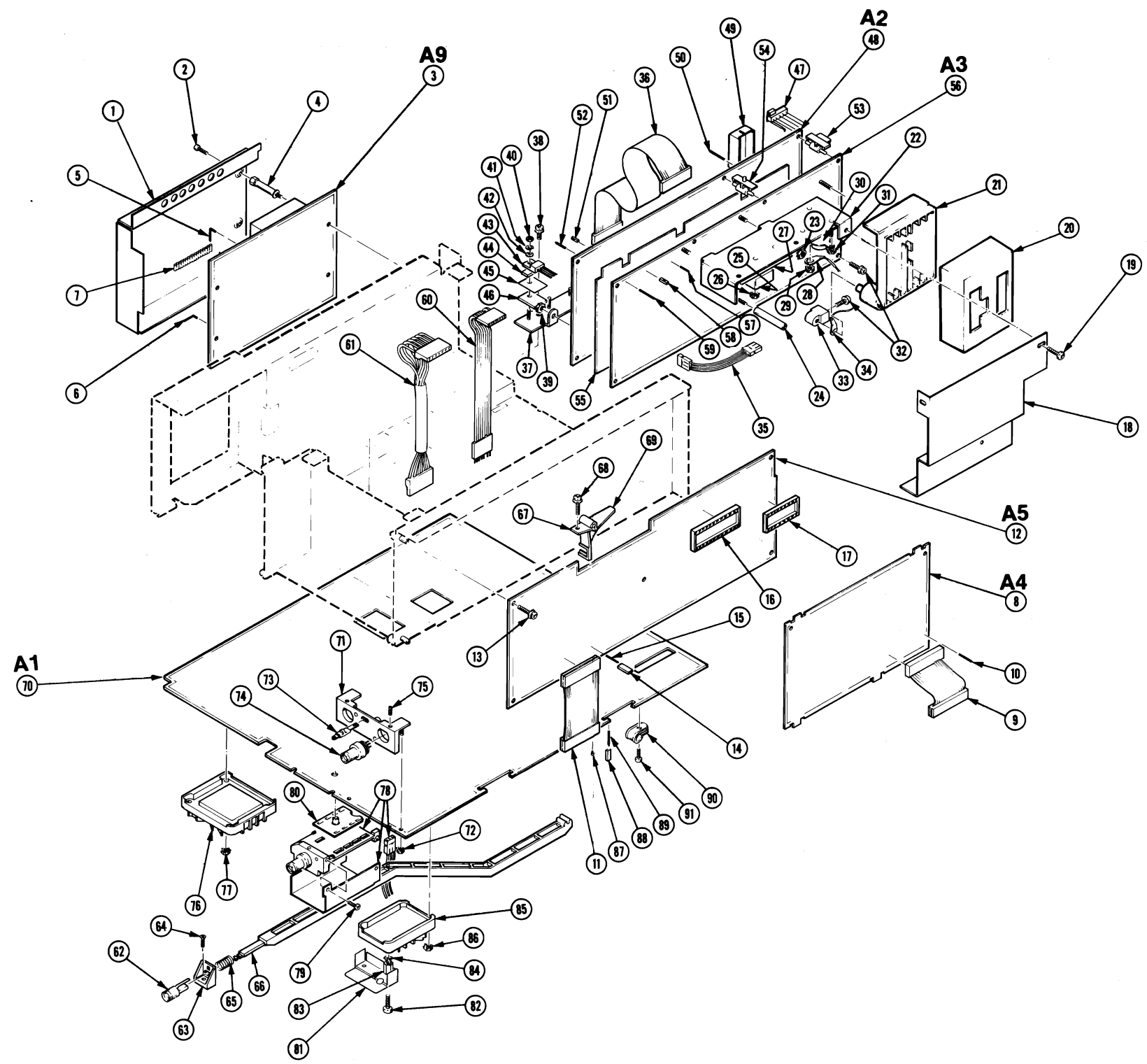

Fig. & Index No.	Tektronix Part No.	Serial/Assembly No.		Qty	12345	Name & Description	Mfr.	
		Effective	Dscont				Code	Mfr. Part No.
4-1	337-2932-01			1		SHIELD,ELEC:HIGH VOLTAGE ATTACHING PARTS	80009	337-2932-01
-2	211-0304-00			4		SCR,ASSEM MSHR:4-40 X 0.312,PNH,STL,T9 END ATTACHING PARTS	01536	ORDER BY ODESCR
-3	-----			1		CKT BOARD ASSY:HIGH VOLTAGE (SEE A9 REPL) ATTACHING PARTS		
-4	361-1188-00			4		SPACER,POST:1.15 L,4-40 THO ONE END,STL END ATTACHING PARTS	80009	361-1188-00
-5	-----			1		.HEADER,MICROCKT:14 PIN,0.5 L,GOLD PL (SEE A9P191 REPL)		
-6	-----			14		.TERMINAL,PIN:0.46 L X 0.025 SQ PH BRZ (SEE A9J901 THRU J904 REPL)		
-7	352-0789-00			1		.HOLDER,TERMINAL:20 SQ PINS	80009	352-0789-00
-8	-----			1		CKT BOARD ASSY:READDUT (SEE A4 REPL)		
-9	-----			1		.CA ASSY,SP,ELEC:26,28 AMG,2.25 L,RIBBON (SEE A4M411 REPL)		
-10	131-0608-00			7		.TERMINAL,PIN:0.365 L X 0.025 BRZ GLD PL	22526	48283-036
-11	-----			1		CA ASSY,SP,ELEC:34,28 AMG,2.0 L (SEE A5M511 REPL)		
	-----			1		CA ASSY,SP,ELEC:26,28 AMG,2.0 L (SEE A5M512 REPL)		
-12	-----			1		CKT BOARD ASSY:DIGITAL CONTROL(SEE A5 REPL) ATTACHING PARTS		
-13	211-0711-00			5		SCR,ASSEM MSHR:6-32 X 0.25,PNH,STL,TORX END ATTACHING PARTS	01536	ORDER BY ODESCR
-14	131-0993-00			2		.BUS,CONDUCTOR:SHUNT ASSEMBLY,BLACK	22526	65474-005
-15	-----			10		.TERMINAL,PIN:0.365 L X 0.025 BRZ GLD PL (SEE A5J501,A5J503,A5TP2070,A5TP2420, .TP2421,TP2701 REPL)		
-16	136-0757-00			1		.SKT,PL-IN ELEK:MICROCIRCUIT,40 DIP	09922	01LB40P-108
-17	136-0755-00			2		.SKT,PL-IN ELEK:MICROCIRCUIT,28 DIP	09922	01LB28P-108
	334-4759-00			1		MARKER,IDENT:MKO SHIELDS INVERTER	80009	334-4759-00
-18	337-2978-00			1		SHIELD,ELEC:LOW VOLTAGE POWER SUPPLY ATTACHING PARTS	80009	337-2978-00
-19	211-0304-00			2		SCR,ASSEM MSHR:4-40 X 0.312,PNH,STL,T9 END ATTACHING PARTS	01536	ORDER BY ODESCR
-20	407-3436-00			1		BRKT,CMPNT MTG:CAP,TOP,ALUMINUM	80009	407-3436-00
-21	407-3437-00			1		BRKT,CMPNT MTG:CAP,BOTTOM,PLASTIC	80009	407-3437-00
-22	407-2854-00			1		BRACKET,ANGLE:TRANSISTOR,ALUMINUM ATTACHING PARTS	80009	407-2854-00
-23	210-0586-00			5		NUT,PL,ASSEM MA:4-40 X 0.25,STL CO PL END ATTACHING PARTS	78189	211-041800-00
-24	129-0304-00			1		SPACER,POST:1.265 L,4-40 EA END,NYL,0.25 00	80009	129-0304-00
-25	343-1025-00			3		RETAINER,XSTR: ATTACHING PARTS	80009	343-1025-00
-26	210-0406-00			3		NUT,PLAIN,HEX:4-40 X 0.188,BRS CO PL END ATTACHING PARTS	73743	12161-50
-27	342-0582-00			3		INSULATOR,PLATE:TRANSISTOR,CERAMIC	80009	342-0582-00
-28	195-6852-00			1		LEAD,ELECTRICAL:18 AMG,2.375 L,8-4 ATTACHING PARTS	80009	195-6852-00
-29	210-0586-00			1		NUT,PL,ASSEM MA:4-40 X 0.25,STL CO PL END ATTACHING PARTS	78189	211-041800-00
-30	342-0354-00			1		INSULATOR,PLATE:TRANSISTOR ATTACHING PARTS	55285	7403-09FR-52
-31	210-0586-00			2		NUT,PL,ASSEM MA:4-40 X 0.25,STL CO PL END ATTACHING PARTS	78189	211-041800-00
-32	211-0711-00			3		SCR,ASSEM MSHR:6-32 X 0.25,PNH,STL,TORX	01536	ORDER BY ODESCR
-33	129-0912-00			1		SPACER,POST:0.62 L,6-32/4-40,POLYMI OE	80009	129-0912-00
-34	195-9720-01			1		LEAD,ELECTRICAL:18 AMG,2.4 L,0-N	80009	195-9720-01
-35	174-0129-00			1		CA ASSY,SP,ELEC:2,22 AMG,5.5 L,9-N	80009	174-0129-00
-36	-----			1		CA ASSY,SP,ELEC:20,28 AMG,13.0 L (SEE A2A1M251 REPL)		
-37	407-2825-00			1		BRACKET,ANGLE:TRANSISTOR MTG,ALUMINUM ATTACHING PARTS	80009	407-2825-00
-38	211-0337-00			3		SCREW,MACHINE:4-40 X 0.25,PNH,SST	01536	ORDER BY ODESCR
-39	210-0586-00			2		NUT,PL,ASSEM MA:4-40 X 0.25,STL CO PL END ATTACHING PARTS	78189	211-041800-00

2445A Replaceable Mechanical Parts
2445A/2455A Service

Fig. & Index No.	Tektronix Part No.	Serial/Assembly No. Effective Dscont	Qty	12345 Name & Description	Mfr. Code	Mfr. Part No.
4-40	210-0406-00		5	NUT,PLAIN,HEX:4-40 X 0.188,BRS CD PL	73743	12161-50
	129-0230-00		1	SPACER,POST:1.375 L,4-40 EA END,BRS	80009	129-0230-00
-41	210-1307-00		6	WASHER,LOCK:0.115 IO,SPLIT,0.025 THK	86928	A384-25N
-42	210-1002-00		6	WASHER,FLAT:0.125 IO X 0.25 00 X 0.022	86928	5714-147-20N
-43	-----		6	TRANSISTOR:(SEE A2Q1220,Q1240,Q1300,U1260, U1330 REPL)		
-44	342-0536-00		6	INSULATOR,XSTR:T0-220,POLYENELENE	80009	342-0536-00
-45	342-0354-00		6	INSULATOR,PLATE:TRANSISTOR	55285	7403-09FR-52
-46	361-1207-00		6	SPACER,PLATE:0.550 X 0.812,AL (XSTR)	80009	361-1207-00
-47	343-1067-01		4	RTNR,ELEC CONN:POLYCARBONATE,BLACK	80009	343-1067-01
	343-1099-01		1	RTNR,POWER SPLY:LOW VOLTAGE,FRONT,PC	80009	343-1099-01
-48	-----		1	CKT BOARD ASSY:REGULATOR(SEE A2 REPL) (AVAILABLE AS 672-1037-XX ONLY)		
-49	200-2735-00		1	.COVER,POWER SW:BLACK,POLYCARBONATE	80009	200-2735-00
-50	-----		22	.TERMINAL,PIN:0.365 L X 0.025 BRZ GLO PL (SEE REPL FOR CKT NUMBERS)		
-51	136-0263-07		18	.SOCKET,PIN TERM:U/M 0.025 SQ PIN	22526	ORDER BY OESCR
-52	-----		4	.TERM QIK DISC:CKT 80 MT,0.11 X 0.02 (SEE A2J204,J205,J206,J207 REPL)		
-53	129-0976-00		1	SPACER,POST:0.86 L X 6-32,POLYCARBONATE,0.3	80009	129-0976-00
-54	361-1132-01		4	SPACER,CKT 80:A POLYCARBONATE	80009	361-1132-01
-55	337-3059-00		1	SHIELD,ELEC:LVP5	80009	337-3059-00
-56	-----		1	CKT BOARD ASSY:INVERTER(SEE A3 REPL)		
-57	-----		7	.TERMINAL,PIN:0.365 L X 0.025 BRZ GLO PL (SEE A3J301,J302 REPL)		
-58	136-0263-07		18	.SOCKET,PIN TERM:U/M 0.025 SQ PIN	22526	ORDER BY OESCR
-59	131-0589-00		4	.TERMINAL,PIN:0.46 L X 0.025 SQ PH BRZ	22526	48283-029
-60	-----		1	CA ASSY,SP,ELEC:6,22 AWG,5.25 L (SEE A1M121 REPL)		
-61	-----		1	CA ASSY,SP,ELEC:8,26 AWG,7.0 L,R1880N (SEE A1M122 REPL)		
-62	366-1767-00		1	PUSH BUTTON:BLACK,YELLOW INDICATOR	31918	160597
-63	407-2904-01		1	BRACKET,EXT SFT:POLYCARBONATE	80009	407-2904-01
-64	211-0718-00		1	SCREW,MACHINE:6-32 X 0.312,FLH,100 DEG,STL	83486	ORDER BY DESCR
-65	214-3328-00		1	SPRING,HLCPS:0.37 OD X 0.7 L,CLE,SST	91260	ORDER BY DESCR
-66	-----		2	ATTENUATOR,VAR:(SEE A1A11,A1A12 REPL)		
	384-1631-00		1	EXTENSION SHAFT:12.897 L X 0.375 OD,PLSTC	80009	384-1631-00
-67	407-2800-00		1	BRACKET,PIVOT:EXTENSION SHAFT,PLASTIC ATTACHING PARTS	80009	407-2800-00
-68	211-0711-00		1	SCR,ASSEM MSHR:6-32 X 0.25,PNH,STL,TORX END ATTACHING PARTS	01536	ORDER BY DESCR
-69	407-2803-00		1	BRACKET,PVT ARM:EXTENSION SHAFT,PLASTIC	80009	407-2803-00
-70	-----		1	CKT BOARD ASSY:MAIN (SEE A1 REPL)		
	195-3985-00		2	.LEAD,ELECTRICAL:26 AWG,1.7 L,9-N (USED WITH A1L628 & A1L633)	80009	195-3985-00
-71	386-4735-01		1	.PLATE,CHPNT MTG:ALUMINUM ATTACHING PARTS	80009	386-4735-01
-72	210-0586-00		2	.NUT,PL,ASSEM MA:4-40 X 0.25,STL CD PL	78189	211-041800-00
	361-0382-00		2	.SPACER,P8 SW:0.275 L,BROWN POLYCARBONATE END ATTACHING PARTS	80009	361-0382-00
-73	131-2716-01		1	.TERMINAL,CAL:	80009	131-2716-01
-74	131-0679-02		2	.CONN,RCPT,ELEC:BNC,MALE,3 CONTACT ATTACHING PARTS	24931	28JR270-1
-75	213-0006-00		2	.SETSCREW:8-32 X 0.188,STL END ATTACHING PARTS	50293	28701-98C-38
-76	-----		9	.MICROCIRCUIT,LI: (A1U700 SHOWN,ALSO SEE A1U100,200,300,400, .500,600,900,950 REPL) ATTACHING PARTS		
-77	210-0586-00		31	.NUT,PL,ASSEM MA:4-40 X 0.25,STL CD PL END ATTACHING PARTS	78189	211-041800-00
-78	-----		2	ATTENUATOR,VAR:(SEE A1A11,A1A12 REPL) ATTACHING PARTS		
-79	211-0304-00		4	.SCR,ASSEM MSHR:4-40 X 0.312,PNH,STL,T9 END ATTACHING PARTS	01536	ORDER BY DESCR
-80	351-0677-01		2	.GUIDE,MAG CATCH:BLACK,PLOYCARBONATE	80009	351-0677-01

2445A Replaceable Mechanical Parts
2445A/2455A Service

Fig. & Index No.	Tektronix Part No.	Serial/Assembly No.		Qty	12345 Name & Description	Mfr. Code	Mfr. Part No.	
		Effective	Discont				Mfr.	Part No.
4-	214-2270-00			3	.CONTACT, ELEC: CRT TO SHLD, CU-BE CU-SN-ZN PL ATTACHING PARTS	80009	214-2270-00	
	211-0324-00			3	.SCR, ASSEM MSHR: 4-40 X 0.188, PNH, T9 TORX OR END ATTACHING PARTS	01536	829-06780-024	
-81	337-3031-00			2	.SHIELD, ELEC: PRE-AMP ATTACHING PARTS	80009	337-3031-00	
-82	211-0324-00			2	.SCR, ASSEM MSHR: 4-40 X 0.188, PNH, T9 TORX OR END ATTACHING PARTS	01536	829-06780-024	
-83	129-0985-00			5	.SPACER, POST: 0.350 L, 4-40 THRU, STL, 0.25 HEX	80009	129-0985-00	
-84	210-0003-00			2	.WASHER, LOCK: #4 EXT, 0.015 THK, STL	78189	1104-00-00-0541C	
-85	214-0973-00			1	.HEAT SINK, XSTR: TO-92, CU BE CO PL ATTACHING PARTS	80009	214-0973-00	
-86	210-0586-00			2	.NUT, PL, ASSEM MA: 4-40 X 0.25, STL CO PL	78189	211-041800-00	
	210-0994-00			1	.WASHER, FLAT: 0.12510 X 0.2500 X 0.022 END ATTACHING PARTS	86928	A371-283-20	
-87	136-0252-07			32	.SOCKET, PIN CONN: W/O OIMPLE	22526	75060-012	
-88	131-0993-00			4	.BUS, CONDUCTOR: SHUNT ASSEMBLY, BLACK	22526	65474-005	
-89	-----			22	.TERMINAL, PIN: 0.365 L X 0.025 BRZ GLD PL (SEE REPL FOR CIRCUIT NUMBERS)			
-90	343-0088-00			1	CLAMP, CABLE: 0.062 DIA, PLASTIC ATTACHING PARTS	80009	343-0088-00	
-91	211-0711-00			1	SCR, ASSEM MSHR: 6-32 X 0.25, PNH, STL, TORX END ATTACHING PARTS	01536	ORDER BY OESCR	
	131-3388-00	8010100	8010188	1	CONN, RCPT, ELEC: CKT 80, 2 X 8, 0.1 SPACING	80009	131-3388-00	
	131-3388-01	8010189		1	CONN, RCPT, ELEC: CKT 80, 2 X 8, 0.1 SPACING	80009	131-3388-01	

2445A Replaceable Mechanical Parts
2445A/2455A Service

Fig. & Index No.	Tektronix Part No.	Serial/Assembly No. Effective	Dscont	Qty	12345 Name & Description	Mfr. Code	Mfr. Part No.
STANDARD ACCESSORIES							
-1	161-0104-06			1	CABLE ASSY,PMR,:3 X 0.75MM SQ,220V,98.0 L	S3109	ORDER BY DESCR
-2	161-0104-05			1	CABLE ASSY,PMR,:3,18 AWG,240V,98.0 L	S3109	ORDER BY DESCR
-3	161-0104-08			1	CABLE ASSY,PMR,:3,18 AWG,240V,98.0 L	70903	ORDER BY DESCR
-4	161-0167-00			1	CABLE ASSY,PMR,:3.0 X 0.75,6A,240V,2.5M L	S3109	ORDER BY DESCR
-5	161-0104-07			1	CABLE ASSY,PMR,:3 X 0.75MM SQ,240V,98.0 L	TK1373	A25UK-RA
-6	134-0016-01			1	ADAPTER,CONN:BANANA W/BINDING POST	80009	134-0016-01
-7	159-0021-00			1	FUSE,CARTRIDGE:3AG,2A,250V,FAST BLOW	71400	AGC-CN-2
-8	378-0208-00			1	FILTER,LT,CRT:CLEAR,4.105 X 3.415,POLY	80009	378-0208-00
-9	-----			4	PROBE,CONTROL:SBP9989 PROTOTYPE		
-10	016-0537-00			1	POUCH,ACCESSORY:6 IN X 9 IN W/ZIPPER	05006	ZIP-6X9ID
-11	200-3199-00	B010100	B010352	1	COVER,FRONT:ABS	80009	200-3199-00
	200-3199-01	B010353		1	COVER,FRONT:ABS	80009	200-3199-01
-12	386-4849-00			1	PLATE,MOUNTING:ACCESSORY POUCH,ALUMINUM	80009	386-4849-00
-13	016-0692-00			1	POUCH,ACCESSORY:	80009	016-0692-00
-14	161-0104-00			1	CABLE ASSY,PMR,:3 WIRE,98.0 L,W/RTANG CONN SAFETY CONTROLLED	16428	CH8352, FH-8352
-15	343-0003-00			1	CLAMP,LOOP:0.25 ID,PLASTIC	06915	E4 CLEAR ROUND
-16	210-0863-00			1	WSHR,LOOP CLAMP:0.187 ID U/W 0.5 W CLP	95987	C191
-17	211-0722-00			1	SCREW,MACHINE:6-32 X 0.25,PNH,STL	80009	211-0722-00
	070-4180-00			1	CARD,INFO:REF,2445/2465 OSCILLOSCOPE	80009	070-4180-00
	070-6014-00			1	MANUAL,TECH:OPERATORS,2445A/55A/65A OPTS	80009	070-6014-00
	062-8934-00	B010180		1	SHEET,TECHNICAL:WCP/CRT NOTICE	80009	062-8934-00
OPTIONAL ACCESSORIES							
	-----			1	ACCESSORY KIT:TWO PROBES,PASSIVE,P6136,W/ACCESSORIES		
	016-0720-00			1	COVER,PROT:NYLON	80009	016-0720-00
	016-0825-00			1	RACK MOUNT KIT:	80009	016-0825-00
	070-6017-00			1	MANUAL,TECH:SERVICE,2455A/45A	80009	070-6017-00
	346-0058-00			1	FASTENER,STRAP:CARRYING	80009	346-0058-00

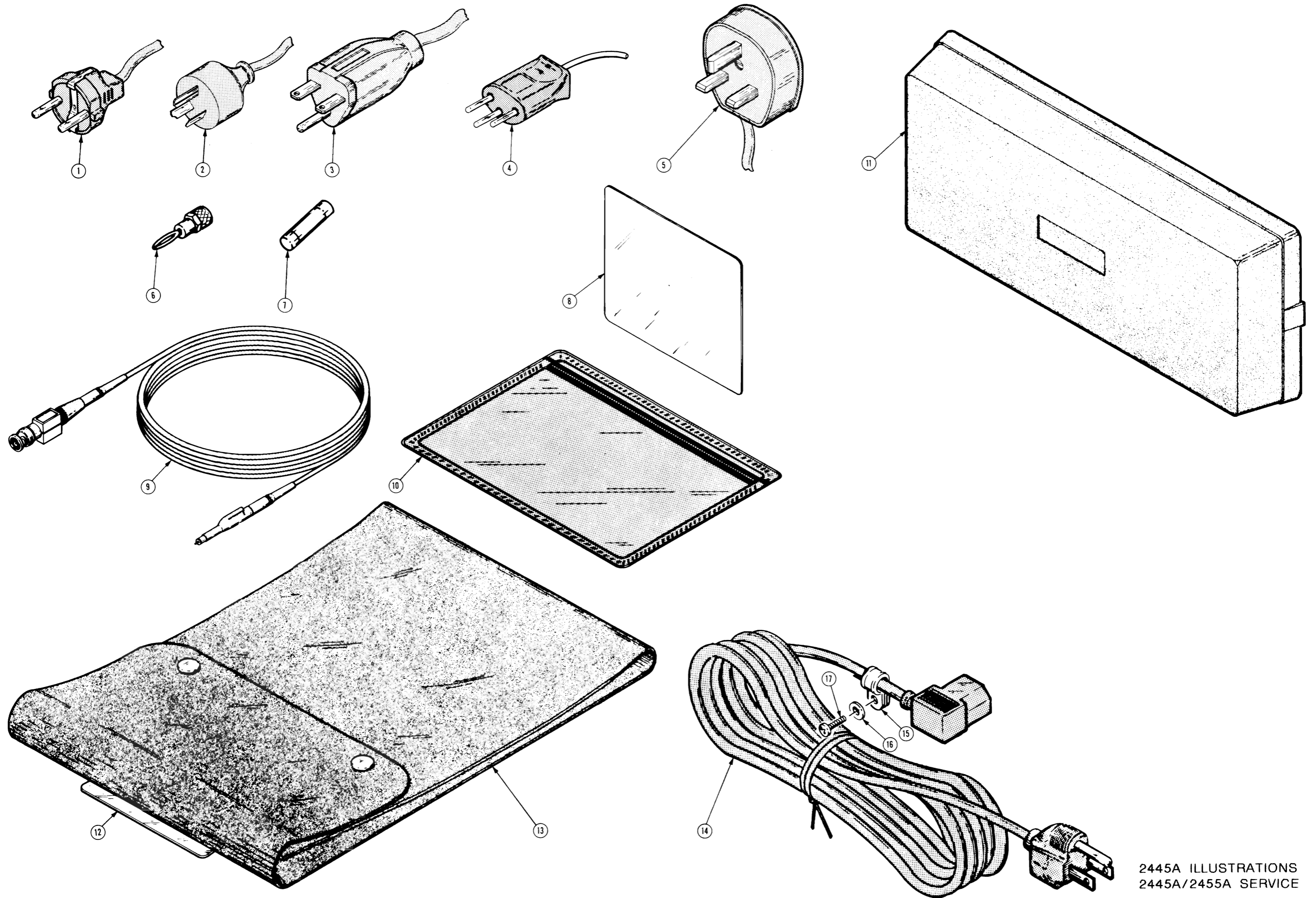

FIG. 5 ACCESSORIES

REPLACEABLE MECHANICAL PARTS

PARTS ORDERING INFORMATION

Replacement parts are available from or through your local Tektronix, Inc. Field Office or representative.

Changes to Tektronix instruments are sometimes made to accommodate improved components as they become available, and to give you the benefit of the latest circuit improvements developed in our engineering department. It is therefore important, when ordering parts, to include the following information in your order: Part number, instrument type or number, serial number, and modification number if applicable.

If a part you have ordered has been replaced with a new or improved part, your local Tektronix, Inc. Field Office or representative will contact you concerning any change in part number.

Change information, if any, is located at the rear of this manual.

ITEM NAME

In the Parts List, an Item Name is separated from the description by a colon (:). Because of space limitations, an Item Name may sometimes appear as incomplete. For further Item Name identification, the U.S. Federal Cataloging Handbook H6-1 can be utilized where possible.

FIGURE AND INDEX NUMBERS

Items in this section are referenced by figure and index numbers to the illustrations.

INDENTATION SYSTEM

This mechanical parts list is indented to indicate item relationships. Following is an example of the indentation system used in the description column.

```

1 2 3 4 5           Name & Description
Assembly and/or Component
Attaching parts for Assembly and/or Component
    **** END ATTACHING PARTS ****
Detail Part of Assembly and/or Component
Attaching parts for Detail Part
    **** END ATTACHING PARTS ****
Parts of Detail Part
Attaching parts for Parts of Detail Part
    **** END ATTACHING PARTS ****
    
```

Attaching Parts always appear in the same indentation as the item it mounts, while the detail parts are indented to the right. Indented items are part of, and included with, the next higher indentation.

Attaching parts must be purchased separately, unless otherwise specified.

ABBREVIATIONS

"	INCH	ELCTRN	ELECTRON	IN	INCH	SE	SINGLE END
#	NUMBER SIZE	ELEC	ELECTRICAL	INCAND	INCANDESCENT	SECT	SECTION
ACTR	ACTUATOR	ELCTLT	ELECTROLYTIC	INSUL	INSULATOR	SEMICOND	SEMICONDUCTOR
ADPTR	ADAPTER	ELEM	ELEMENT	INTL	INTERNAL	SHLD	SHIELD
ALIGN	ALIGNMENT	EPL	ELECTRICAL PARTS LIST	LPHLDR	LAMPHOLDER	SHLDR	SHOULDERED
AL	ALUMINUM	EQPT	EQUIPMENT	MACH	MACHINE	SKT	SOCKET
ASSEM	ASSEMBLED	EXT	EXTERNAL	MECH	MECHANICAL	SL	SLIDE
ASSY	ASSEMBLY	FIL	FILLISTER HEAD	MTG	MOUNTING	SLFLKG	SELF-LOCKING
ATTEN	ATTENUATOR	FLEX	FLEXIBLE	NIP	NIPPLE	SLVG	SLEEVING
AWG	AMERICAN WIRE GAGE	FLH	FLAT HEAD	NON WIRE	NOT WIRE WOUND	SPR	SPRING
BD	BOARD	FLTR	FILTER	OBD	ORDER BY DESCRIPTION	SQ	SQUARE
BRKT	BRACKET	FR	FRAME or FRONT	OD	OUTSIDE DIAMETER	SST	STAINLESS STEEL
BRS	BRASS	FSTNR	FASTENER	OVH	OVAL HEAD	STL	STEEL
BRZ	BRONZE	FT	FOOT	PH BRZ	PHOSPHOR BRONZE	SW	SWITCH
BSHG	BUSHING	FXD	FIXED	PL	PLAIN or PLATE	T	TUBE
CAB	CABINET	GSKT	GASKET	PLSTC	PLASTIC	TERM	TERMINAL
CAP	CAPACITOR	HDL	HANDLE	PN	PART NUMBER	THD	THREAD
CER	CERAMIC	HEX	HEXAGON	PNH	PAN HEAD	THK	THICK
CHAS	CHASSIS	HEX HD	HEXAGONAL HEAD	PWR	POWER	TNSN	TENSION
CKT	CIRCUIT	HEX SOC	HEXAGONAL SOCKET	RCPT	RECEPTACLE	TPG	TAPPING
COMP	COMPOSITION	HLCPS	HELICAL COMPRESSION	RES	RESISTOR	TRH	TRUSS HEAD
CONN	CONNECTOR	HLEXT	HELICAL EXTENSION	RGD	RIGID	V	VOLTAGE
COV	COVER	HV	HIGH VOLTAGE	RLF	RELIEF	VAR	VARIABLE
CPLG	COUPLING	IC	INTEGRATED CIRCUIT	RTNR	RETAINER	W/	WITH
CRT	CATHODE RAY TUBE	ID	INSIDE DIAMETER	SCH	SOCKET HEAD	WSHR	WASHER
DEG	DEGREE	IDENT	IDENTIFICATION	SCOPE	OSCILLOSCOPE	XFMR	TRANSFORMER
DWR	DRAWER	IMPLR	IMPELLER	SCR	SCREW	XSTR	TRANSISTOR

CROSS INDEX - MFR. CODE NUMBER TO MANUFACTURER

Mfr. Code	Manufacturer	Address	City, State, Zip Code
01536	TEXTRON INC CAMCAR DIV SEMS PRODUCTS UNIT	1818 CHRISTINA ST	ROCKFORD IL 61108
05006	20TH CENTURY PLASTICS INC	3628 CRENSHAM BLVD	LOS ANGELES CA 90015
06915	RICHCO PLASTIC CO	5825 N TRIPP AVE	CHICAGO IL 60646
09772	WEST COAST LOCKWASHER CO INC	16730 E JOHNSON DRIVE P O BOX 3588	CITY OF INDUSTRY CA 91744
09922	BURNODY CORP	RICHARDS AVE	NORMALK CT 06852
12327	FREEMAY CORP	9301 ALLEN OR	CLEVELAND OH 44125
16428	BELEDEN CORP ELECTRONIC DIV	2200 US HWY 27 SOUTH P O BOX 1980	RICHMOND IN 47374
22526	DU PONT E I DE NEMOURS AND CO INC DU PONT CONNECTOR SYSTEMS	30 HUNTER LANE	CAMP HILL PA 17011
24931	SPECIALTY CONNECTOR CO INC	2620 ENORESS PLACE P O BOX 0	GREENWOOD IN 46142
31918	ITT SCHAUM INC	8081 WALLACE RD	EDEN PRAIRIE MN 55343
50293	GENERAL ELECTRIC CO ENGINEERING DEPT		
54583	TOK ELECTRONICS CORP	755 EASTGATE BLVD	GARDEN CITY NY 11530
55285	BERGQUIST CO INC THE	5300 EDINA INDUSTRIAL BLVD	MINNEAPOLIS MN 55435
70903	BELEDEN CORP	2000 S BATAVIA AVE	GENEVA IL 60134
71400	BUSSMANN MFG CO MCGRAM EDISION CO	114 OLD STATE RD PO BOX 14460	ST LOUIS MO 63178
73743	FISCHER SPECIAL MFG CO	446 MORGAN ST	CINCINNATI OH 45206
78189	ILLINOIS TOOL WORKS INC SHAKEPROOF DIVISION	ST CHARLES ROAD	ELGIN IL 60120
80009	TEXTRONIX INC	4900 S M GRIFFITH DR P O BOX 500	BEAVERTON OR 97077
80033	MICRODOT MANUFACTURING INC PRESTOLE EVERLOCK DIV	1345 MIAMI ST P O BOX 278	TOLEDO OH 43605
83385	MICRODOT MANUFACTURING INC GREER-CENTRAL DIV	3221 W BIG BEAVER RD	TROY MI 48098
83486	ELCO INDUSTRIES INC	1101 SAMUELSON RD	ROCKFORD IL 61101
85480	BRADY M H CO	727 W GLENDALE AVE	MILWAUKEE WI 53209
86928	SEASTROM MFG CO INC	701 SONORA AVE	GLENDALE CA 91201
91260	CONNOR SPRING AND MFG CO	1729 JUNCTION AVE	SAN JOSE CA 95112
93907	TEXTRON INC CAMCAR DIV	600 18TH AVE	ROCKFORD IL 61101
95987	MECKESSER CO INC	4444 WEST IRVING PARK RD	CHICAGO IL 60641
93109	FELLER ASA ADOLF AG C/O PANEL COMPONENTS CORP	355 TESCONI CIRCLE	SANTA ROSA CA 95401
93629	SCHURTER AG H C/O PANEL COMPONENTS CORP	2015 SECOND STREET	BERKELEY CA 94170
TK0435	LEWIS SCREM CO	4114 S PEDRIA	CHICAGO IL 60609
TK0861	H SCHURTER AG OIST PANEL COMPONENTS	2015 SECOND STREET	BERKELEY CA 94170
TK1285	GEROME MFG CO INC	PO BOX 737	NEWBURG OR 97132
TK1328	NIDEC AMERICA CORP	882 TRANSFER RD	ST PAUL MN 55114
TK1373	PATELEC-CEM (ITALY)	10156 TORINO	VAICENTALLO 62/455 ITALY
TK1634	SCHRAMM PLASTICS	8770 SW BURNHAM	TIGARD OR 97223

2455A Replaceable Mechanical Parts
2445A/2455A Service

Fig. & Index No.	Tektronix Part No.	Serial/Assembly No.		Qty	12345	Name & Description	Mfr. Code	Mfr. Part No.	
		Effective	Discont						
1-1	334-6643-00			1		MARKER,IDENT:MKO TEKTRONIX 2455A	80009	334-6643-00	
-2	366-2041-03			4		KNOB:DOVE GRAY,BAR,0.172 X 0.41 X 0.496	80009	366-2041-03	
	377-0512-01			4		INSERT,KNOB:0.172 ID X 0.28 OD X 0.64,NYL	80009	377-0512-01	
	366-2036-00			1		PUSH BUTTON:GY,0.206 SQ,1.445 H	80009	366-2036-00	
-3	334-6335-00			1		MARKER,IDENT:MKO CRT CONTROLS	80009	334-6335-00	
-4	200-2779-00			1		COVER, TOP:TRIM	80009	200-2779-00	
-5	348-0740-00			2		FOOT,CABINET:BOTTOM FRONT,PLASTIC ATTACHING PARTS	80009	348-0740-00	
-6	211-0718-00			2		SCREW,MACHINE:6-32 X 0.312,FLH,100 DEG,STL END ATTACHING PARTS	83486	ORDER BY OESCR	
-7	101-0082-02			1		TRIM,DECORATIVE:FRONT,PLASTIC ATTACHING PARTS	80009	101-0082-02	
-8	211-0718-00			10		SCREW,MACHINE:6-32 X 0.312,FLH,100 DEG,STL	83486	ORDER BY OESCR	
	214-3374-01			1		SPRING,FILTER:1.32 L,CU-BE END ATTACHING PARTS	80009	214-3374-01	
-9	337-2926-03			1		SHLD,IMPLSION:4.44 X 3.67 X 0.06,CLEAR	80009	337-2926-03	
	378-0199-03			1		FILTER,LT,CRT:BLUE,3.415 X 4.105 X 0.030 TH K,ACRYLIC PLEXIGLAS	TK1634	378019903	
-10	334-4378-01			1		MARKER,IDENT:MKO PROBE POMER	80009	334-4378-01	
-11	334-4381-02			1		MARKER,IDENT:MKO CONNECTOR IDENT	80009	334-4381-02	
-12	334-4377-04			1		MARKER,IDENT:MKO CAUTION	80009	334-4377-04	
-13	348-0729-00			2		FOOT,CABINET:W/CORO WRAP,REAR,BLACK PU ATTACHING PARTS	80009	348-0729-00	
-14	212-0154-00			4		SCREW,MACHINE:8-32 X 1.125,PNH,STL	83385	ORDER BY OESCR	
	211-0722-00			2		SCREW,MACHINE:6-32 X 0.25,PNH,STL END ATTACHING PARTS	80009	211-0722-00	
-15	200-2685-02			1		COVER,REAR:POLYCARBONATE	80009	200-2685-02	
-16	334-6645-00			1		MARKER,IDENT:MKO TEKTRONIX 2455A HANDLE	80009	334-6645-00	
-17	367-0303-04			1		HANDLE,CARRYING:12.86 L,GRIP & INDEX ATTACHING PARTS	80009	367-0303-04	
-18	212-0144-00			2		SCREW,TPG,TF:8-16 X 0.562,PLASTITE,SPCL HO END ATTACHING PARTS	93907	225-38131-012	
-19	437-0286-03			1		CABINET,SCOPE:ALUMINUM	80009	437-0286-03	
	348-0764-03			1		SHLD GSKT,ELEK:0.125X0.188,MIRE MESH,34.0 L	80009	348-0764-03	

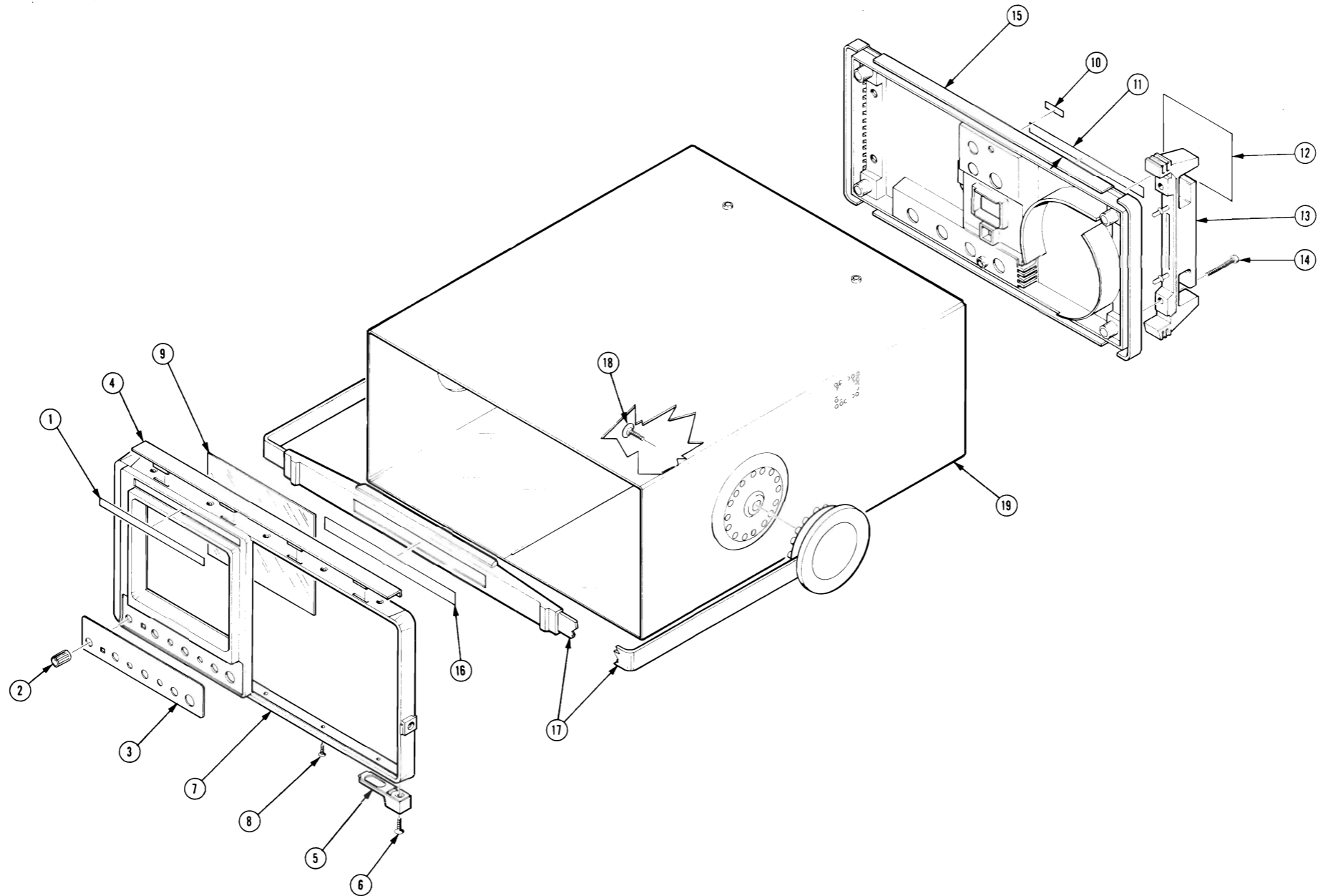

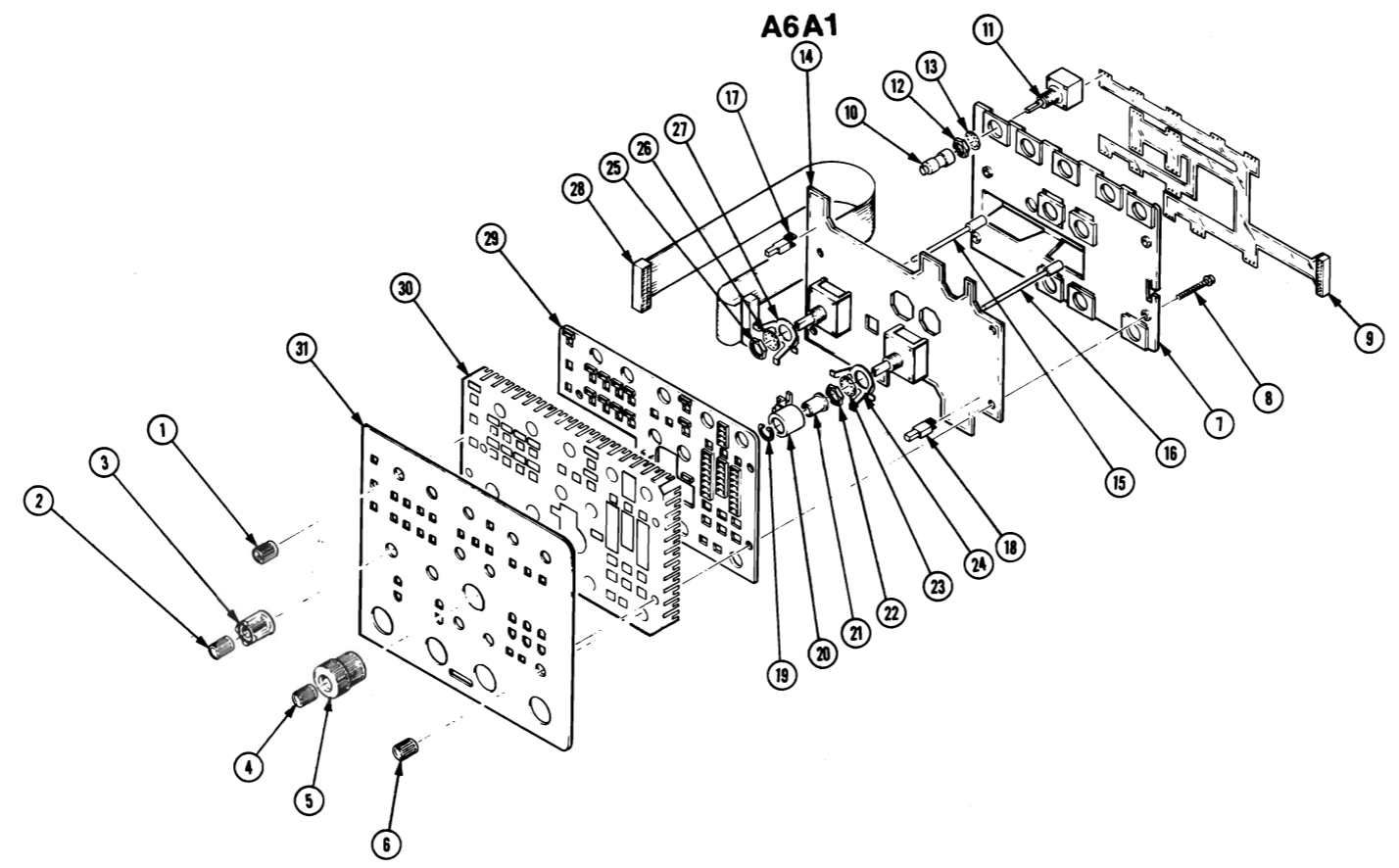

Fig. & Index No.	Tektronix Part No.	Serial/Assembly No.		Qty	12345	Name & Description	Mfr.	
		Effective	Dscont				Code	Mfr. Part No.
2-1	366-2041-03			7		KNOB:DOVE GRAY,BAR,0.172 X 0.41 X 0.496	80009	366-2041-03
-2	366-1510-00			2		KNOB:DOVE GRAY,VAR,0.127 X 0.392 X 0.466	80009	366-1510-00
-3	366-1227-00			2		KNOB:DOVE GY,VOLTS/DIV,0.486 X 0.706 X 0.6	80009	366-1227-00
-4	366-1510-00			1		KNOB:DOVE GRAY,VAR,0.127 X 0.392 X 0.466	80009	366-1510-00
-5	366-1220-01			1		KNOB:DOVE GY,TIME/DIV,0.65 X 0.855 X 0.8	80009	366-1220-01
-6	366-1833-01			3		KNOB:DOVE GRAY,0.25 ID X 0.392 00 X 0.466 H	80009	366-1833-01
-7	352-0790-01			1		HLDR,VAR,RES:BLACK POLYCARBONATE ATTACHING PARTS	80009	352-0790-01
-8	211-0302-00			4		SCR,ASSEM WSHR:4-40 X 0.75,PNH,STL,TORX DR ENO ATTACHING PARTS	01536	ORDER BY DESCR
-9	259-0025-00			1		FLEX CIRCUIT:POLYIMIDE	80009	259-0025-00
-10	377-0413-00			10		INSERT,KNOB:0.055 ID X 0.37 00 X 0.821,PM	80009	377-0413-00
-11	-----			13		RES,VAR,NONMM:(SEE A6R3007 THRU R3019 REPL) ATTACHING PARTS		
-12	220-0495-00			13		NUT,PLAIN,HEX:0.375-32 X 0.438 HEX,BRS	73743	ORDER BY DESCR
-13	210-0012-00			13		WASHER,LDCK:0.384 ID,INTL,0.022 THK,STL ENO ATTACHING PARTS	09772	ORDER BY DESCR
-14	-----			1		CIRCUIT 80 ASSY:FRONT PANEL(SEE A6A1 REPL)		
-15	384-1684-01			2		.SHAFT,VARIABLE:2.16 L,POLYCARBONATE	80009	384-1684-01
-16	384-1683-01			1		.SHAFT,VARIABLE:2.36 L,POLYCARBONATE	80009	384-1683-01
-17	366-1516-00			20		.PUSH BUTTON:IVORY GRAY,0.3 X 0.665 H,SQ	80009	366-1516-00
-18	366-1538-00			10		.PUSH BUTTON:IVORY GY,0.3 X 0.665,RND	80009	366-1538-00
-19	354-0669-00			1		.RING,RETAINING:CRESENT,0.438 OD	80009	354-0669-00
-20	214-3824-01			1		.ACTUATOR,SWITCH:TIME PER DIV	80009	214-3824-01
-21	377-0412-01			1		.INSERT,KNOB:0.182 X 0.5 X 0.393,POLY	80009	377-0412-01
-22	220-0495-00			1		.NUT,PLAIN,HEX:0.375-32 X 0.438 HEX,BRS	73743	ORDER BY DESCR
-23	210-0012-00			1		.WASHER,LDCK:0.384 ID,INTL,0.022 THK,STL	09772	ORDER BY DESCR
-24	214-3373-00			1		.SPRING,GROUND:PHOSPHOR-BRONZE	80009	214-3373-00
-25	220-0495-00			2		.NUT,PLAIN,HEX:0.375-32 X 0.438 HEX,BRS	73743	ORDER BY DESCR
-26	210-0012-00			2		.WASHER,LDCK:0.384 ID,INTL,0.022 THK,STL	09772	ORDER BY DESCR
-27	214-3373-00			2		.SPRING,GROUND:PHOSPHOR-BRONZE	80009	214-3373-00
-28	175-9916-00			1		.CA ASSY,SP,ELEC:20,28 AWG,11.0 L	80009	175-9916-00
-29	351-0750-00			1		GUIOE,SMITCH:ABS,BLACK	80009	351-0750-00
-30	354-0655-00			1		RING,MOUNTING:FR PNL,4.16 X 6.065,BRASS	80009	354-0655-00
-31	333-3274-00			1		PANEL,FRONT:	80009	333-3274-00

2455A Replaceable Mechanical Parts
2445A/2455A Service

Fig. & Index No.	Tektronix Part No.	Serial/Assembly No. Effective Dscont	Qty	12345 Name & Description	Mfr. Code	Mfr. Part No.
3-1	407-2790-02		1	BRACKET,CKT 80:VERTICAL,ALUMINUM ATTACHING PARTS	80009	407-2790-02
-2	211-0711-00		4	SCR,ASSEM MSHR:6-32 X 0.25,PNH,STL,TORX	01536	ORDER BY OESCR
-3	211-0722-00		2	SCREW,MACHINE:6-32 X 0.25,PNH,STL END ATTACHING PARTS	80009	211-0722-00
-4	343-1012-00		2	RETAINER,CKT 80:POLYCARBONATE	80009	343-1012-00
-5	426-1864-01		1	FRAME,CRT: ATTACHING PARTS	80009	426-1864-01
-6	211-0713-00		4	SCREW,MACHINE:6-32 X 1.25,FLH,100 DEG,STL	83385	ORDER BY OESCR
-7	213-0978-00		6	SCREW,TPG,TR:6-32 X 0.5,FLH,100DEG,STL END ATTACHING PARTS	80009	213-0978-00
-8	343-0992-00		2	RETAINER,CRT:CLEAR,PLASTIC (UPPER RT/LOWER LEFT/NAT)	80009	343-0992-00
-9	343-0993-00		2	RETAINER,CRT:BLACK,PLASTIC (UPPER LEFT/LOWER RT/BLK)	80009	343-0993-00
-10	348-0731-01		1	GASKET:CRT,POLYETHYLENE	80009	348-0731-01
-11	378-0204-00		1	REFLECTOR,LIGHT:INT SCALE ILLUMINATION	80009	378-0204-00
-12	-----		1	CKT BOARD ASSY:SCALE ILLUM (SEE A8 REPL)		
-13	386-4728-01		1	SUBPANEL,FRONT:	80009	386-4728-01
-14	348-0792-01		1	GASKET:ELECTRICAL SHIELD,34.0 L	80009	348-0792-01
-15	175-4593-01		1	CA ASSY,SP,ELEC:2,22 AWG,3.5 L,RIBBON	80009	175-4593-01
-16	386-4713-02		1	PLATE,REAR:POWER SUPPLY ATTACHING PARTS	80009	386-4713-02
-17	211-0711-00		5	SCR,ASSEM MSHR:6-32 X 0.25,PNH,STL,TORX END ATTACHING PARTS	01536	ORDER BY OESCR
	337-3059-00		1	SHIELD,ELEC:LVP5	80009	337-3059-00
	343-1099-01		1	RTNR,POWER SPLY:LOW VOLTAGE,FRONT,PC	80009	343-1099-01
	334-3379-00		1	MARKER,IDENT:MARKED GROUND SYMBOL	80009	334-3379-00
-18	195-3984-00		1	LEAD,ELECTRICAL:22 AWG,4.0 L,8-01	80009	195-3984-00
-19	334-6652-00		1	MARKER,IDENT:MKD CAUTION BATTERY	80009	334-6652-00
-20	211-0304-00		2	SCR,ASSEM MSHR:4-40 X 0.312,PNH,STL,T9	01536	ORDER BY OESCR
-21	386-4863-00		1	SUPPORT,CKT 80:	80009	386-4863-00
-22	378-0275-00		1	DEFLECTOR,AIR:ALUMINUM ATTACHING PARTS	80009	378-0275-00
-23	211-0711-00		1	SCR,ASSEM MSHR:6-32 X 0.25,PNH,STL,TORX END ATTACHING PARTS	01536	ORDER BY OESCR
-24	119-2102-00		1	FAN,TUBEAXIAL:12V,1.5M,3200RPM,24CFM	TK1328	119-2102-00
-25	337-3021-01		1	SHIELD,ELEC:LVP5 PEDPLE ATTACHING PARTS	80009	337-3021-01
-26	211-0711-00		2	SCR,ASSEM MSHR:6-32 X 0.25,PNH,STL,TORX END ATTACHING PARTS	01536	ORDER BY OESCR
-27	334-5196-00		1	MARKER,IDENT:MKD CAUTION (STANDARD,OPTIONS 05,06,09,10)	80009	334-5196-00
-28	200-2264-00		1	CAP,FUSEHOLDER:3AG FUSES	53629	FEX 031 1666
-29	204-0832-00		1	BODY,FUSEHOLDER:3AG & 5 X 20MM FUSES	TK0861	031 1673
-30	200-0237-04		1	COVER,FUHLR:PLASTIC	80009	200-0237-04
-31	195-3984-00		1	LEAD,ELECTRICAL:22 AWG,4.0 L,8-01	80009	195-3984-00
	195-3986-00		1	LEAD,ELECTRICAL:18 AWG,4.0 L,8-0 ATTACHING PARTS	80009	195-3986-00
-32	210-0457-00		1	NUT,PL,ASSEM MA:6-32 X 0.312,STL CO PL END ATTACHING PARTS (OPTION 11 PARTS INCLUDE:)	78189	511-061800-00
-33	175-6044-01		2	.CA ASSY,SP,ELEC:4,26 AWG,6.0 L,RIBBON (TO A2J201,A2J202)	80009	175-6044-01
-34	210-0012-00		2	.WASHER,LOCK:0.384 ID,INTL,0.022 THK,STL	09772	ORDER BY OESCR
-35	210-0978-00		2	.WASHER,FLAT:0.375 ID X 0.5 OD X 0.024,STL	12327	ORDER BY OESCR
-36	386-5052-00		1	.PLATE,ADAPTER:PROBE POWER,ALUMINUM	80009	386-5052-00
	334-1529-01		1	.PLATE,IDENT:BLANK	80009	334-1529-01
-37	119-1536-00		1	FILTER,RFI:3A,250VAC,50/60HZ ATTACHING PARTS	54583	ZUB2203-00
-38	211-0332-00		2	SCR,ASSEM MSHR:4-40 X 0.5,PNH,STL,T9	01536	ORDER BY OESCR
-39	210-0586-00		2	NUT,PL,ASSEM MA:4-40 X 0.25,STL CO PL END ATTACHING PARTS	78189	211-041800-00
-40	195-3989-00		1	LEAD,ELECTRICAL:18 AWG,4.0 L,8-9	80009	195-3989-00
-41	195-3990-00		1	LEAD,ELECTRICAL:18 AWG,4.5 L,5-4	80009	195-3990-00
-42	211-0304-00		2	SCR,ASSEM MSHR:4-40 X 0.312,PNH,STL,T9	01536	ORDER BY OESCR
-43	210-0586-00		2	NUT,PL,ASSEM MA:4-40 X 0.25,STL CO PL	78189	211-041800-00

Fig. & Index No.	Tektronix Part No.	Serial/Assembly No. Effective Dscont	Qty	12345 Name & Description	Mfr. Code	Mfr. Part No.
3-44	-----		1	SWITCH,SLIDE:DPOT (SEE S90 REPL)		
-45	195-3987-00		1	LEAD,ELECTRICAL:22 AWG,2.6 L,8-19	80009	195-3987-00
	195-3988-00		1	LEAD,ELECTRICAL:22 AWG,4.0 L,8-29	80009	195-3988-00
-46	-----		4	NUT,PLAIN,KNURL:(FURN WITH 131-1910-01 BNC)		
-47	-----		4	WASHER,LOCK:(FURN WITH 131-1910-01 BNC'S)		
-48	131-1910-01		4	CONN,RCPT,ELEC:BNC,FEMALE	24931	28JR284-1
-49	200-2686-00		1	COVER,REAR:CRT	80009	200-2686-00
				ATTACHING PARTS		
-50	211-0711-00		3	SCR,ASSEM WSHR:6-32 X 0.25,PNH,STL,TORX	01536	ORDER BY DESC
				END ATTACHING PARTS		
-51	195-8410-00		1	LEAD,ELECTRICAL:22 AWG,1.65 L	80009	195-8410-00
				ATTACHING PARTS		
-52	210-0551-00		1	NUT,PLAIN,HEX:4-40 X 0.25,ST CO PL	TK0435	ORDER BY DESC
				END ATTACHING PARTS		
-53	195-9513-00		1	LEAD,ELECTRICAL:22 AWG,1.4 L,	80009	195-9513-00
				ATTACHING PARTS		
-54	210-0551-00		1	NUT,PLAIN,HEX:4-40 X 0.25,ST CO PL	TK0435	ORDER BY DESC
				END ATTACHING PARTS		
-55	344-0250-00		1	RETAINER,CAP.:0.5 DIA,STEEL	80033	E50005-007
				ATTACHING PARTS		
-56	211-0747-00		1	SCREW,MACHINE:6-32 X 0.188,PNH,STL	80009	211-0747-00
				END ATTACHING PARTS		
-57	307-1154-00		1	PASSIVE NETWORK:CRT TERMINATOR	80009	307-1154-00
				ATTACHING PARTS		
-58	211-0304-00		2	SCR,ASSEM WSHR:4-40 X 0.312,PNH,STL,T9	01536	ORDER BY DESC
-59	210-0457-00		2	NUT,PL,ASSEM MA:6-32 X 0.312,STL CO PL	78189	511-061800-00
				END ATTACHING PARTS		
-60	407-2809-00		1	BRACKET,ANGLE:RESISTOR,AL	80009	407-2809-00
				ATTACHING PARTS		
-61	210-0583-00		2	NUT,PLAIN,HEX:D.25-32 X 0.312,BRS CO PL	73743	2X-20319-402
				END ATTACHING PARTS		
	334-1951-00		1	MARKER,IOENT:MKO WARNING,CRT VOLTAGES	80009	334-1951-00
-62	337-2931-01		1	SHIELD,CRT:	TK1285	337-2931-01
				ATTACHING PARTS		
-63	211-0337-00		4	SCREW,MACHINE:4-40 X 0.25,PNH,SST	01536	ORDER BY DESC
				END ATTACHING PARTS		
-64	200-0917-01		1	COVER,CRT SKT:2.052 OD X 0.291 H,PLASTIC	80009	200-0917-01
-65	-----		1	WIRE SET,ELEC:M/CRT SOCKET		
				(SEE A9M900 AND A9P900 REPL)		
-66	214-0291-00		2	CONTACT,ELEC:CRT CONNECTOR,CU BE SIL PL	80009	214-0291-00
				ATTACHING PARTS		
-67	211-0324-00		2	SCR,ASSEM WSHR:4-40 X 0.188,PNH,T9 TORX OR	01536	829-06780-024
-68	210-0586-00		2	NUT,PL,ASSEM MA:4-40 X 0.25,STL CO PL	78189	211-041800-00
				END ATTACHING PARTS		
-69	-----		1	COIL,TUBE DEFL:FXD,TRACE ROTATION		
				(SEE L90 REPL)		
-70	348-0762-00		1	GROMMET,PLASTIC:BLACK,ROUND,0.54 ID	80009	348-0762-00
-71	195-6851-01		1	LEAD,ELECTRICAL:BRAIDED,1.65 L	80009	195-6851-01
	195-8410-00		1	LEAD,ELECTRICAL:22 AWG,1.65 L	80009	195-8410-00
				ATTACHING PARTS		
-72	211-0337-00		2	SCREW,MACHINE:4-40 X 0.25,PNH,SST	01536	ORDER BY DESC
-73	210-0551-00		2	NUT,PLAIN,HEX:4-40 X 0.25,ST CO PL	TK0435	ORDER BY DESC
				END ATTACHING PARTS		
-74	-----		1	CKT BD ASSY:DYNAMIC CENTERING (SEE A14)		
				ATTACHING PARTS		
-75	361-0067-00		3	SPACER,CKT 80:0.187,NYLON	06915	LC853M
				END ATTACHING PARTS		
-76	-----		5	.TERMINAL,PIN:0.365 L X 0.025 BRZ GLD PL		
				.(SEE A124J141 REPL)		
-77	175-4596-00		1	CA ASSY,SP,ELEC:5,22 AWG,7.0 L,RIBBON	80009	175-4596-00
-78	348-0757-00		1	GROMMET,PLASTIC:BLACK,U SHAPE,0.25 ID	80009	348-0757-00
-79	343-0081-00		1	STRAP,RETAINING:0.125 DIA,NYLON	85480	CPNY-1728K
				ATTACHING PARTS		
-80	210-0457-00		1	NUT,PL,ASSEM MA:6-32 X 0.312,STL CO PL	78189	511-061800-00
				END ATTACHING PARTS		
-81	348-0763-00		1	GROMMET,PLASTIC:NATURAL,OVAL,1.235 ID	80009	348-0763-00
-82	348-0751-00		1	GROMMET,PLASTIC:NATURAL,3.11 X 0.645 OBLONG	80009	348-0751-00

2455A Replaceable Mechanical Parts
2445A/2455A Service

Fig. & Index No.	Tektronix Part No.	Serial/Assembly No. Effective Dscont	Qty	12345	Name & Description	Mfr. Code	Mfr. Part No.
3-83	343-1012-00		2		RETAINER,CKT 80:POLYCARBONATE	80009	343-1012-00
-84	441-1618-02		1		CHASSIS,SCOPE:	80009	441-1618-02

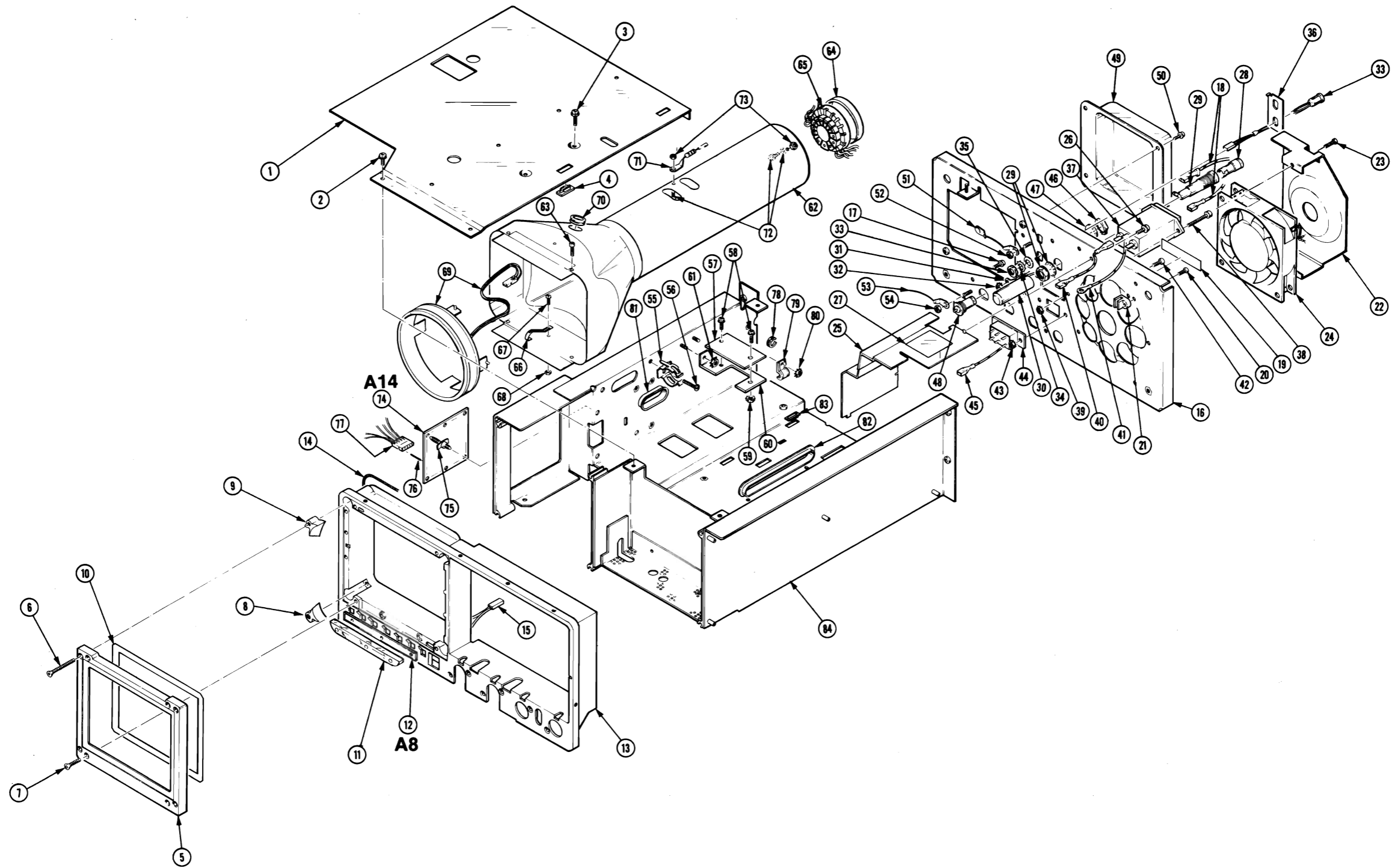

FIG. 3 CHASSIS

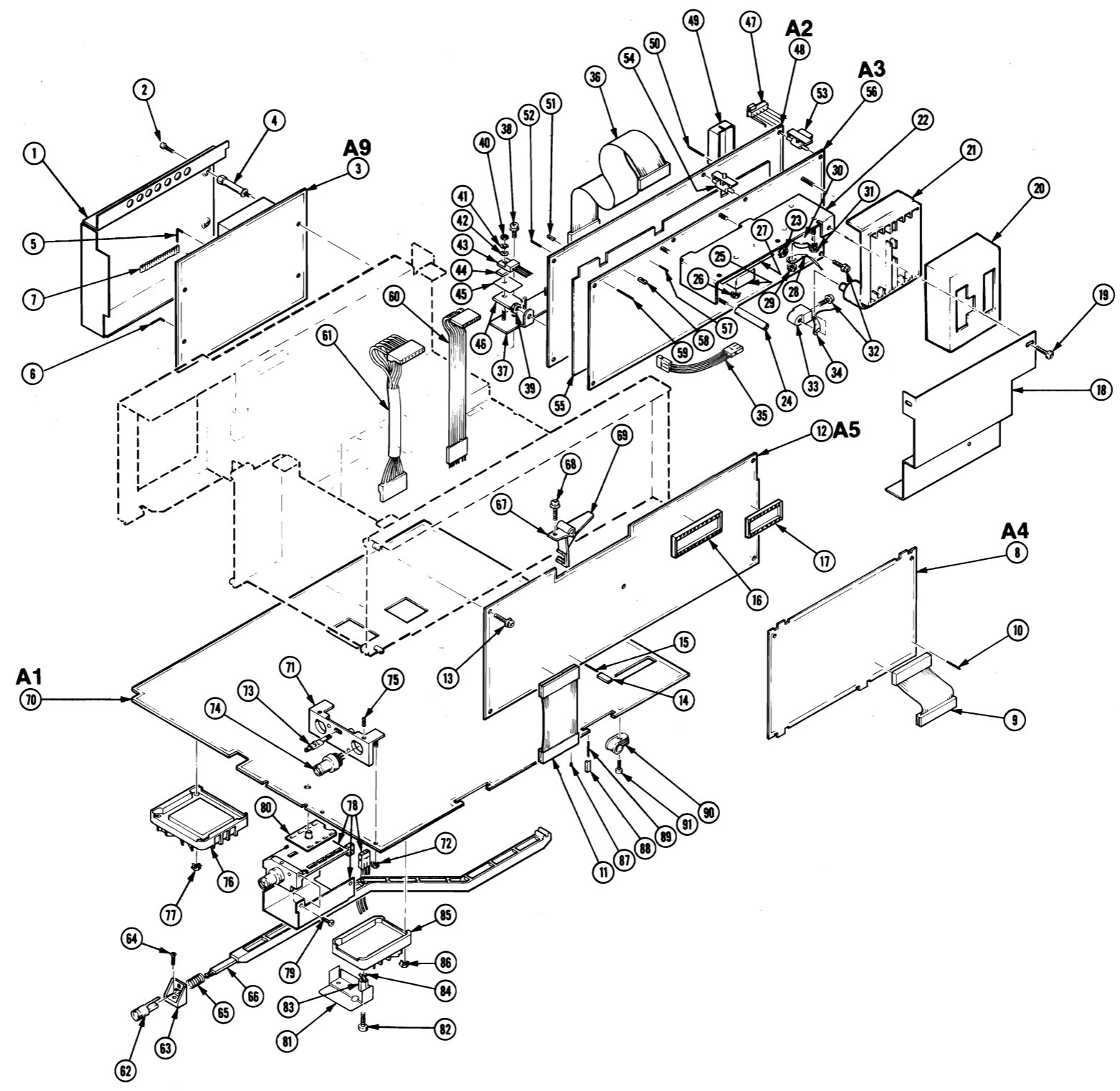

Fig. & Index No.	Tektronix Part No.	Serial/Assembly No.		Qty	12345 Name & Description	Mfr.	
		Effective	Dscont			Code	Mfr. Part No.
4-1	337-2932-01			1	SHIELD,ELEC:HIGH VOLTAGE ATTACHING PARTS	80009	337-2932-01
-2	211-0304-00			4	SCR,ASSEM WSHR:4-40 X 0.312,PNH,STL,T9 END ATTACHING PARTS	01536	ORDER BY OESCR
-3	-----			1	CKT BOARD ASSY:HIGH VOLTAGE (SEE A9 REPL) ATTACHING PARTS		
-4	361-1188-00			4	SPACER,POST:1.15 L,4-40 THO ONE END,STL END ATTACHING PARTS	80009	361-1188-00
-5	-----			1	.HEADER,MICROCKT:14 PIN,0.5 L,GOLD PL (SEE A9P191 REPL)		
-6	-----			14	.TERMINAL,PIN:0.46 L X 0.025 SQ PH BRZ (SEE A9J901 THRU J904 REPL)		
-7	352-0789-00			1	.HOLDER,TERMINAL:20 SQ PINS	80009	352-0789-00
-8	-----			1	CKT BOARD ASSY:READOUT (SEE A4 REPL)		
-9	-----			1	.CA ASSY,SP,ELEC:26,28 AMG,2.25 L,RIBBON (SEE A4M411 REPL)		
-10	131-0608-00			7	.TERMINAL,PIN:0.365 L X 0.025 BRZ GLD PL	22526	48283-036
-11	-----			1	CA ASSY,SP,ELEC:34,28 AMG,2.0 L (SEE A5M511 REPL)		
	-----			1	CA ASSY,SP,ELEC:26,28 AMG,2.0 L (SEE A5M512 REPL)		
-12	-----			1	CKT BOARD ASSY:OIGITAL CONTROL(SEE A5 REPL) ATTACHING PARTS		
-13	211-0711-00			5	SCR,ASSEM WSHR:6-32 X 0.25,PNH,STL,TORX END ATTACHING PARTS	01536	ORDER BY OESCR
-14	131-0993-00			2	.BUS,CONDUCTOR:SHUNT ASSEMBLY,BLACK	22526	65474-005
-15	-----			10	.TERMINAL,PIN:0.365 L X 0.025 BRZ GLD PL (SEE A5J501,A5J503,A5TP2070,A5TP2420, .TP2421,TP2701 REPL)		
-16	136-0757-00			1	.SKT,PL-IN ELEK:MICROCIRCUIT,40 OIP	09922	D1LB40P-108
-17	136-0755-00			2	.SKT,PL-IN ELEK:MICROCIRCUIT,28 OIP	09922	O1LB28P-108
	334-4759-00			1	MARKER,IDENT:MKO SHIELDS INVERTER	80009	334-4759-00
-18	337-2978-00			1	SHIELD,ELEC:LOW VOLTAGE POWER SUPPLY ATTACHING PARTS	80009	337-2978-00
-19	211-0304-00			2	SCR,ASSEM WSHR:4-40 X 0.312,PNH,STL,T9 END ATTACHING PARTS	01536	ORDER BY OESCR
-20	407-3436-00			1	BRKT,CMPNT MTG:CAP,TOP,ALUMINUM	80009	407-3436-00
-21	407-3437-00			1	BRKT,CMPNT MTG:CAP,BOTTOM,PLASTIC	80009	407-3437-00
-22	407-2854-00			1	BRACKET,ANGLE:TRANSISTOR,ALUMINUM ATTACHING PARTS	80009	407-2854-00
-23	210-0586-00			5	NUT,PL,ASSEM MA:4-40 X 0.25,STL CO PL END ATTACHING PARTS	78189	211-041800-00
-24	129-0304-00			1	SPACER,POST:1.265 L,4-40 EA ENO,NYL,0.25 00	80009	129-0304-00
-25	343-1025-00			3	RETAINER,XSTR: ATTACHING PARTS	80009	343-1025-00
-26	210-0406-00			3	NUT,PLAIN,HEX:4-40 X 0.188,BRS CO PL END ATTACHING PARTS	73743	12161-50
-27	342-0582-00			3	INSULATOR,PLATE:TRANSISTOR,CERAMIC	80009	342-0582-00
-28	195-6852-00			1	LEAD,ELECTRICAL:18 AMG,2.375 L,B-4 ATTACHING PARTS	80009	195-6852-00
-29	210-0586-00			1	NUT,PL,ASSEM MA:4-40 X 0.25,STL CO PL END ATTACHING PARTS	78189	211-041800-00
-30	342-0354-00			1	INSULATOR,PLATE:TRANSISTOR ATTACHING PARTS	55285	7403-09FR-52
-31	210-0586-00			2	NUT,PL,ASSEM MA:4-40 X 0.25,STL CO PL END ATTACHING PARTS	78189	211-041800-00
-32	211-0711-00			3	SCR,ASSEM WSHR:6-32 X 0.25,PNH,STL,TORX	01536	ORDER BY OESCR
-33	129-0912-00			1	SPACER,POST:0.62 L,6-32/4-40,POLYWIDE	80009	129-0912-00
-34	195-9720-01			1	LEAD,ELECTRICAL:18 AMG,2.4 L,0-N	80009	195-9720-01
-35	174-0129-00			1	CA ASSY,SP,ELEC:2,22 AMG,5.5 L,9-N	80009	174-0129-00
-36	-----			1	CA ASSY,SP,ELEC:20,28 AMG,13.0 L (SEE A2A1M251 REPL)		
-37	407-2825-00			1	BRACKET,ANGLE:TRANSISTOR MTG,ALUMINUM ATTACHING PARTS	80009	407-2825-00
-38	211-0337-00			3	SCREW,MACHINE:4-40 X 0.25,PNH,SST	01536	ORDER BY DESCR
-39	210-0586-00			2	NUT,PL,ASSEM MA:4-40 X 0.25,STL CO PL END ATTACHING PARTS	78189	211-041800-00

2455A Replaceable Mechanical Parts
2445A/2455A Service

Fig. & Index No.	Tektronix Part No.	Serial/Assembly No.		Qty	12345	Name & Description	Mfr.	
		Effective	Dscont				Code	Mfr. Part No.
4-40	210-0406-00			5		NUT, PLAIN, HEX:4-40 X 0.188, BR5 CO PL	73743	12161-50
	129-0230-00			1		SPACER, POST:1.375 L, 4-40 EA END, BR5	80009	129-0230-00
-41	210-1307-00			6		WASHER, LOCK:0.115 ID, SPLIT, 0.025 THK	86928	A384-25N
-42	210-1002-00			6		WASHER, FLAT:0.125 ID X 0.25 OD X 0.022	86928	5714-147-20N
-43	-----			6		TRANSISTOR: (SEE A2Q1220, Q1240, Q1300, U1260, U1330 REPL)		
-44	342-0536-00			6		INSULATOR, XSTR: T0-220, POLYENELENE	80009	342-0536-00
-45	342-0354-00			6		INSULATOR, PLATE: TRANSISTOR	55285	7403-09FR-52
-46	361-1207-00			6		SPACER, PLATE: 0.550 X 0.812, AL (XSTR)	80009	361-1207-00
-47	343-1067-01			4		RTNR, ELEC CONN: POLYCARBONATE, BLACK	80009	343-1067-01
	343-1099-01			1		RTNR, POWER SPLY: LOW VOLTAGE, FRONT, PC	80009	343-1099-01
-48	-----			1		CKT BOARD ASSY: REGULATOR (SEE A2 REPL) (AVAILABLE AS 672-1037-XX ONLY)		
-49	200-2735-00			1		.COVER, POWER SW: BLACK, POLYCARBONATE	80009	200-2735-00
-50	-----			22		.TERMINAL, PIN: 0.365 L X 0.025 BRZ GLD PL (SEE REPL FOR CKT NUMBERS)		
-51	136-0263-07			18		.SOCKET, PIN TERM: U/M 0.025 SQ PIN	22526	ORDER BY OESCR
-52	-----			4		.TERM QIK 01SC: CKT 80 MT, 0.11 X 0.02 (SEE A2J204, J205, J206, J207 REPL)		
-53	129-0976-00			1		SPACER, POST: 0.86 L X 6-32, POLYCARBONATE, 0.3	80009	129-0976-00
-54	361-1132-01			4		SPACER, CKT 80: A POLYCARBONATE	80009	361-1132-01
-55	337-3059-00			1		SHIELD, ELEC: LVPS	80009	337-3059-00
-56	-----			1		CKT BOARD ASSY: INVERTER (SEE A3 REPL)		
-57	-----			7		.TERMINAL, PIN: 0.365 L X 0.025 BRZ GLD PL (SEE A3J301, J302 REPL)		
-58	136-0263-07			18		.SOCKET, PIN TERM: U/M 0.025 SQ PIN	22526	ORDER BY OESCR
-59	131-0589-00			4		.TERMINAL, PIN: 0.46 L X 0.025 SQ PH BRZ	22526	48283-029
-60	-----			1		CA ASSY, SP, ELEC: 6.22 AMG, 5.25 L (SEE A1M121 REPL)		
-61	-----			1		CA ASSY, SP, ELEC: 8.26 AMG, 7.0 L, RIBBON (SEE A1M122 REPL)		
-62	366-1767-00			1		PUSH BUTTON: BLACK, YELLOW INDICATOR	31918	160597
-63	407-2904-01			1		BRACKET, EXT SFT: POLYCARBONATE	80009	407-2904-01
-64	211-0718-00			1		SCREW, MACHINE: 6-32 X 0.312, FLH, 100 DEG, STL	83486	ORDER BY OESCR
-65	214-3328-00			1		SPRING, HLCPS: 0.37 OD X 0.7 L, CLE, SST	91260	ORDER BY OESCR
-66	-----			2		ATTENUATOR, VAR: (SEE A1A11, A1A12 REPL)		
	384-1631-00			1		EXTENSION SHAFT: 12.897 L X 0.375 OD, PLSTC	80009	384-1631-00
-67	407-2800-00			1		BRACKET, PIVOT: EXTENSION SHAFT, PLASTIC ATTACHING PARTS	80009	407-2800-00
-68	211-0711-00			1		SCR, ASSEM MSHR: 6-32 X 0.25, PNH, STL, TORX END ATTACHING PARTS	01536	ORDER BY OESCR
-69	407-2803-00			1		BRACKET, PVT ARM: EXTENSION SHAFT, PLASTIC	80009	407-2803-00
-70	-----			1		CKT BOARD ASSY: MAIN (SEE A1 REPL)		
	195-3985-00			2		.LEAD, ELECTRICAL: 26 AMG, 1.7 L, 9-N (USED WITH A1L628 & A1L633)	80009	195-3985-00
-71	386-4735-01			1		.PLATE, CMPNT MTG: ALUMINUM ATTACHING PARTS	80009	386-4735-01
-72	210-0586-00			2		.NUT, PL, ASSEM MA: 4-40 X 0.25, STL CO PL	78189	211-041800-00
	361-0382-00			2		.SPACER, PB SW: D.275 L, BROWN POLYCARBONATE END ATTACHING PARTS	80009	361-0382-00
-73	131-2716-01			1		.TERMINAL, CAL:	80009	131-2716-01
-74	131-0679-02			2		.CONN, RCPT, ELEC: BNC, MALE, 3 CONTACT ATTACHING PARTS	24931	28JR270-1
-75	213-0006-00			2		.SETSCREW: 8-32 X 0.188, STL END ATTACHING PARTS	50293	28701-98C-38
-76	-----			9		.MICROCIRCUIT, LI: (A1U700 SHOWN, ALSO SEE A1U100, 200, 300, 400, .500, 600, 900, 950 REPL) ATTACHING PARTS		
-77	210-0586-00			31		.NUT, PL, ASSEM MA: 4-40 X 0.25, STL CO PL END ATTACHING PARTS	78189	211-041800-00
-78	-----			2		ATTENUATOR, VAR: (SEE A1A11, A1A12 REPL) ATTACHING PARTS		
-79	211-0304-00			4		.SCR, ASSEM MSHR: 4-40 X 0.312, PNH, STL, T9 END ATTACHING PARTS	01536	ORDER BY OESCR
-80	351-0677-01			2		.GUIDE, MAG CATCH: BLACK, POLYCARBONATE	80009	351-0677-01

2455A Replaceable Mechanical Parts
2445A/2455A Service

Fig. & Index No.	Tektronix Part No.	Serial/Assembly No.		Qty	12345 Name & Description	Mfr.	
		Effective	Discont			Code	Mfr. Part No.
4-	214-2270-00			3	.CONTACT,ELEC:CRT TO SHLD,CU-BE CU-SN-ZN PL ATTACHING PARTS	80009	214-2270-00
	211-0324-00			3	.SCR,ASSEM WSHR:4-40 X 0.188,PNH,T9 TORX OR END ATTACHING PARTS	01536	829-06780-024
-81	337-3031-00			2	.SHIELD,ELEC:PRE-AMP ATTACHING PARTS	80009	337-3031-00
-82	211-0324-00			2	.SCR,ASSEM WSHR:4-40 X 0.188,PNH,T9 TORX OR END ATTACHING PARTS	01536	829-06780-024
-83	129-0985-00			5	.SPACER,POST:0.350 L,4-40 THRU,STL,0.25 HEX	80009	129-0985-00
-84	210-0003-00			2	.WASHER,LOCK:#4 EXT,0.015 THK,STL	78189	1104-00-00-0541C
-85	214-0973-00			1	.HEAT SINK,XSTR:TO-92,CU BE CO PL ATTACHING PARTS	80009	214-0973-00
-86	210-0586-00			2	.NUT,PL,ASSEM MA:4-40 X 0.25,STL CO PL	78189	211-041800-00
	210-0994-00			1	.WASHER,FLAT:0.12510 X 0.2500 X 0.022 END ATTACHING PARTS	86928	A371-283-20
-87	136-0252-07			32	.SOCKET,PIN CONN:M/O DIMPLE	22526	75060-012
-88	131-0993-00			4	.BUS,CONDUCTOR:SHUNT ASSEMBLY,BLACK	22526	65474-005
-89	-----			22	.TERMINAL,PIN:0.365 L X 0.025 BRZ GLD PL (SEE REPL FOR CIRCUIT NUMBERS)		
-90	343-0088-00			1	CLAMP,CABLE:0.062 DIA,PLASTIC ATTACHING PARTS	80009	343-0088-00
-91	211-0711-00			1	SCR,ASSEM WSHR:6-32 X 0.25,PNH,STL,TORX END ATTACHING PARTS	01536	ORDER BY OESCR
	131-3388-01			1	CONN,RCPT,ELEC:CKT BD,2 X 8,0.1 SPACING	80009	131-3388-01

2455A Replaceable Mechanical Parts
2445A/2455A Service

Fig. & Index No.	Tektronix Part No.	Serial/Assembly No. Effective Dscont	Qty	12345 Name & Description	Mfr. Code	Mfr. Part No.
5-						
STANDARD ACCESSORIES						
-1	161-0104-06		1	CABLE ASSY,PMR,:3 X 0.75MM SQ,220V,98.0 L	S3109	ORDER BY DESCR
-2	161-0104-05		1	CABLE ASSY,PMR,:3,18 AWG,240V,98.0 L	S3109	ORDER BY DESCR
-3	161-0104-08		1	CABLE ASSY,PMR,:3,18 AWG,240V,98.0 L	70903	ORDER BY DESCR
-4	161-0167-00		1	CABLE ASSY,PMR,:3.0 X 0.75,6A,240V,2.5M L	S3109	ORDER BY DESCR
-5	161-0104-07		1	CABLE ASSY,PMR,:3 X 0.75MM SQ,240V,98.0 L	TK1373	A25UK-RA
-6	134-0016-01		1	ADAPTER,CONN:BANANA M/BINDING POST	80009	134-0016-01
-7	159-0021-00		1	FUSE,CARTRIDGE:3AG,2A,250V,FAST BLOW	71400	AGC-CM-2
-8	378-0208-00		1	FILTER,LT,CRT:CLEAR,4.105 X 3.415,POLY	80009	378-0208-00
-9	-----		4	PROBE,CONTROL:SBP9989 PROTOTYPE		
-10	016-0537-00		1	POUCH,ACCESSORY:6 IN X 9 IN M/ZIPPER	05006	ZIP-6X9ID
-11	200-3199-01		1	COVER,FRONT:ABS	80009	200-3199-01
-12	386-4849-00		1	PLATE,MOUNTING:ACCESSORY POUCH,ALUMINUM	80009	386-4849-00
-13	016-0692-00		1	POUCH,ACCESSORY:	80009	016-0692-00
-14	161-0104-00		1	CABLE ASSY,PMR,:3 WIRE,98.0 L,M/RTANG CONN SAFETY CONTROLLED	16428	CH8352, FH-8352
-15	343-0003-00		1	CLAMP,LOOP:0.25 ID,PLASTIC	06915	E4 CLEAR ROUND
-16	210-0863-00		1	MSHR,LOOP CLAMP:0.187 ID U/M 0.5 M CLP	95987	C191
-17	211-0722-00		1	SCREW,MACHINE:6-32 X 0.25,PNH,STL	80009	211-0722-00
	062-8934-00		1	SHEET,TECHNICAL:MCP/CRT NOTICE	80009	062-8934-00
	070-4180-00		1	CARD,INFO:REF,2445/2465 OSCILLOSCOPE	80009	070-4180-00
	070-6014-00		1	MANUAL,TECH:OPERATORS,2445A/55A/65A OPTS	80009	070-6014-00
OPTIONAL ACCESSORIES						
	-----		1	ACCESSORY KIT:TWO PROBES,PASSIVE,P6136,M/AC CESSORIES		
	016-0720-00		1	COVER,PROT:NYLON	80009	016-0720-00
	016-0825-00		1	RACK MOUNT KIT:	80009	016-0825-00
	070-6017-00		1	MANUAL,TECH:SERVICE,2455A/45A	80009	070-6017-00
	346-0058-00		1	FASTENER,STRAP:CARRYING	80009	346-0058-00

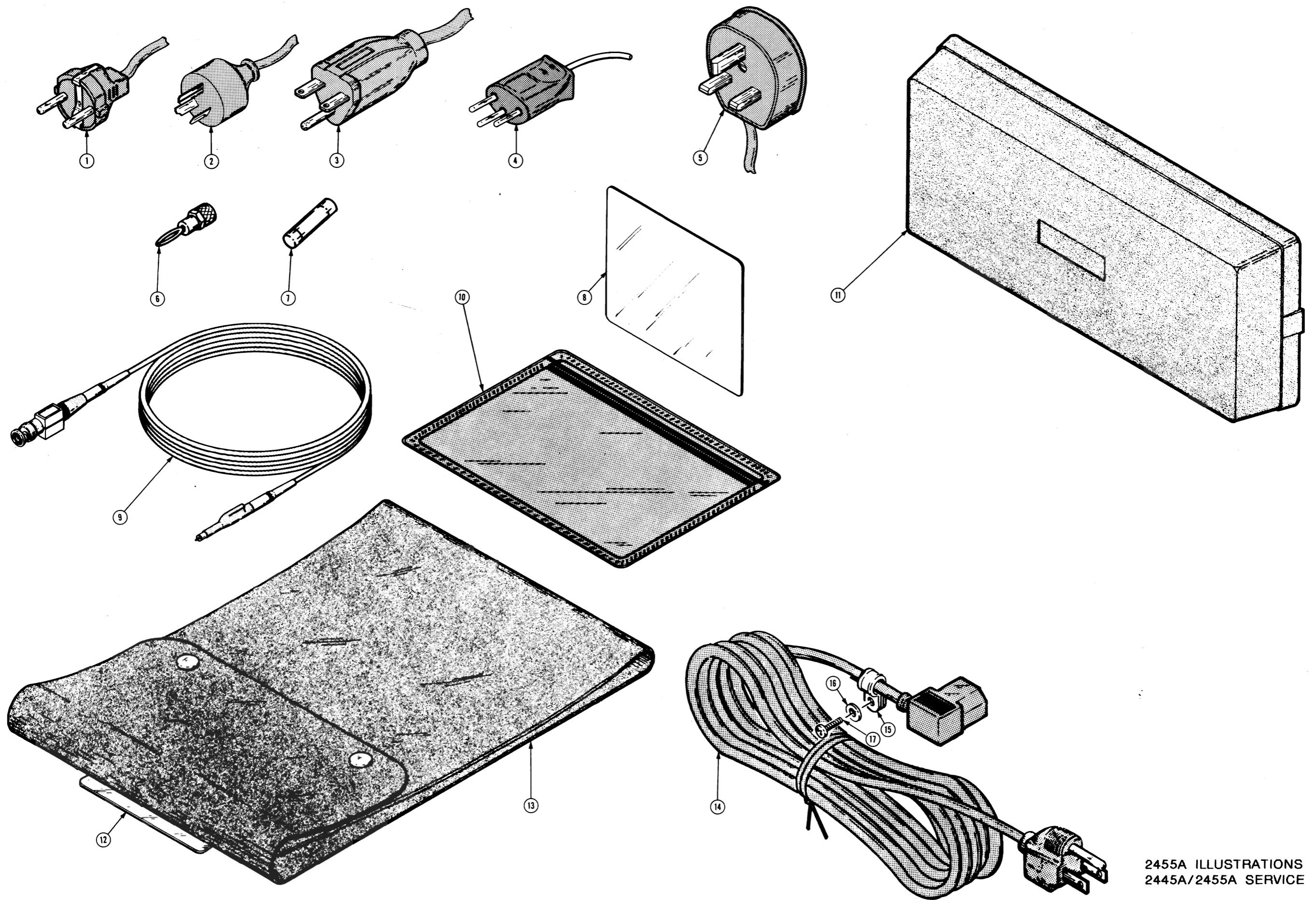

FIG. 5 ACCESSORIES

MANUAL CHANGE INFORMATION

At Tektronix, we continually strive to keep up with latest electronic developments by adding circuit and component improvements to our instruments as soon as they are developed and tested.

Sometimes, due to printing and shipping requirements, we can't get these changes immediately into printed manuals. Hence, your manual may contain new change information on following pages.

A single change may affect several sections. Since the change information sheets are carried in the manual until all changes are permanently entered, some duplication may occur. If no such change pages appear following this page, your manual is correct as printed.