

Pressure Sensors

24PC Series

Absolute Unamplified Noncompensated

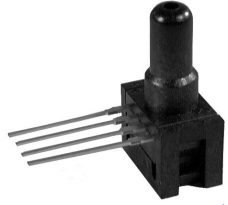

FEATURES

- Absolute pressure measurement
- Miniature package
- 2-15 and 2-30 psi pressure ranges
- 2 mA constant current excitation significantly reduces sensitivity shift over temperature*

24PC PERFORMANCE SPECIFICATIONS

Accuracy Specifications @ 10.0 ± .01 VDC Excitation, 25°C

Parameter	Range psia	bar	Min.	Typ.	Max.	Units
Excitation			—	10	12	VDC
Null Shift	2-15	1		±2.0	±4.0	mV
0 to 25°C, 25 to 50°C	2-30	2		±2.0	±5.5	
Linearity	2-15	1		.10	.20	% Span
B.F.S.L. P2 < P1**	2-30	2		.15	.30	
Sensitivity Shift						
0 to 25°C, 25 to 50°C	All			±5.0	±6.5	% Span
Repeatability & Hysteresis	All			±0.5		% Span
Input Resistance			4.0 K	5.0 K	6.0 K	Ohms
Output Resistance			4.0 K	5.0 K	6.0 K	Ohms
Weight			—	2.0	—	grams

ENVIRONMENTAL SPECIFICATIONS

Operating Temperature	−40 to +85°C (−40 to +185°F)
Storage Temperature	−55 to +100°C (−67 to +212°F)
Shock	Qualification tested to 150 G
Vibration	Qualification tested to 0 to 2 kHz, 20 G sine
Media Compatibility	Limited only to those media which will not attack polyetherimide, silicon, fluorosilicone and silicone seals.

*Span: the algebraic difference between output end points

**B.F.S.L.: Best Fit Straight Line

24PC ABSOLUTE ORDER GUIDE

Catalog Listing Type	Pressure Range psia	Span, mV			Null Offset mV			Sensitivity mV/psi Typ.	Over-pressure psia Typ.
		Min.	Typ.	Max.	Min.	Typ.	Max.		
24PCC	2-15	−140	−200	−260	−46	−16	+14	15	45
24PCD	2-30	−160	−300	−440	−61	−16	+29	11	60

* Non-compensated pressure sensors, excited by constant current instead of voltage, exhibit temperature compensation of Span. Application Note #1 briefly discusses current excitation.

Constant current excitation has an additional benefit of temperature measurement. When driven by a constant current source, a silicon pressure sensor's terminal voltage will rise with increased temperature. The rise in voltage not only compensates the Span, but is also an indication of die temperature.

Constant Current Excitation Schematic

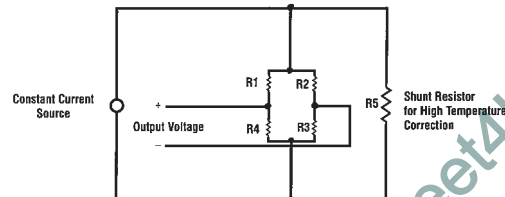

Unamplified

Pressure Sensors

24PC Series

Absolute Unamplified Noncompensated

24PC SERIES ABSOLUTE PRESSURE SENSOR OUTPUT CURVE

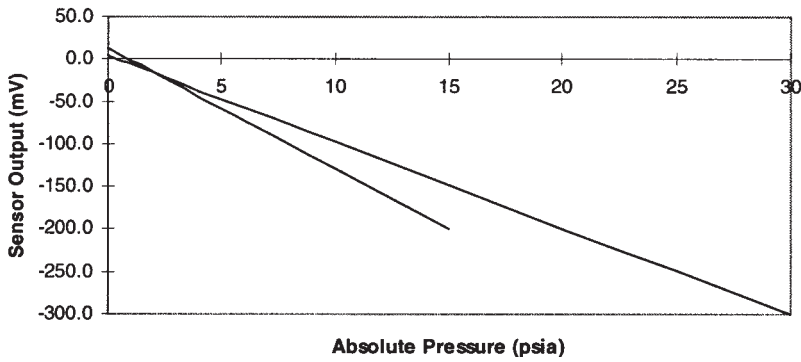

EXCITATION SCHEMATIC

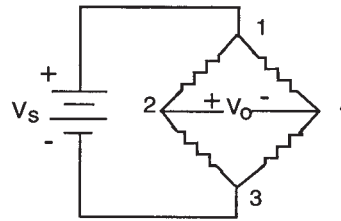

TERMINATION STYLE

Style 6 - 1 x 4
 Pin 1 = Vs (+)
 Pin 2 = Output (+)
 Pin 3 = Ground (-)
 Pin 4 = Output (-)

Pin 1 is notched
 Pin 2 is next to Pin 1, etc.

SENSOR SELECTION GUIDE

2 Product Family	4 Circuit Type	PC Pressure Transducer	C Pressure Range	F** Type of Seal	D* Type of Port (P1)	6 Termination Style	A Pressure Measurement
2 20PC Family	4 Standard noncompensated		C 2-15 psia 1 bar D 2-30 psia 2 bar	F Fluoro-silicone	A Straight D Modular	6 1 x 4 (.600" long)	A Absolute

*Port type refers to P1

**Media seal is on P1 side and will not be in contact with media

Example: 24PCCFD6A

Non-compensated 15 psi Absolute sensor with fluorosilicone seal, modular port, 1 x 4 terminals, .600" long.

See **Accessory Guide**, page 27.

MOUNTING DIMENSIONS (for reference only)

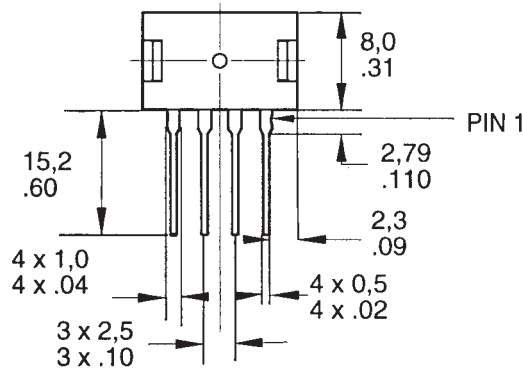

A Straight Port

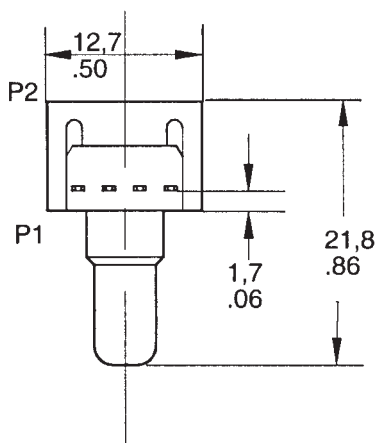

D Modular Port

