



2D51 Duct Smoke Detector for Special Applications

The System Sensor 2D51 low-profile photoelectric smoke detector with a B210LP base tied to the D4P120 is listed to Underwriters Laboratories 268A specifically for use in no-flow/low-flow air-handling systems.



Features for 2D51/B210LP/D4P120

- Low-profile smoke detector design
- Low standby current
- Two LEDs blink in standby
- Detector head plugs easily into base
- Built-in test switch
- Field sensitivity metering of detector to meet the requirements of NFPA 72 with the use of RTS2/RTS2-AOS and SENS-RDR
- Designed for mounting on a standard electrical box
- SEMS screws for easy wiring and positive wire retention
- Removable cover and insect screen for field cleaning
- Remote push button Test/Reset, LEDs provide visual indications
- Onboard supervisory and alarm relays
- Accepts 24 or 120V supply voltage
- Interconnect up to 100 units for common functions
- Compatible for interconnection with System Sensor InnoviarFlex™ D4120 or D4120W duct smoke detectors and remote accessories

The 2D51 can be used as a pendant mount detector in no-flow/low-flow air-handling systems (0-4,000 FPM). The pendant /plenum mounted **2D51** is to be installed into a **B210LP** base and wired to a **D4P120** power board-only control unit. The D4P120 power board is capable of controlling up to two 2D51 sensors.

Pendant mounted in a standard electrical box within the duct, the twist-in/twist-out head allows easy removal from the base for quick cleaning and maintenance. The 2D51 heads can be locally tested using a magnet or by using the test/reset push button on the D4P120 power board.

Remote testing is accomplished using the RTS151, RTS151KEY, RTS-2 or RTS-AOS accessories connected to the D4P120 power board.

The APA151, RTS2 and RTS2-AOS Remote Annunciators with Piezo Alarm can also be connected to the D4P120 power board to provide an audible and visible indication of smoke detector status.

Agency Listings



7272-1653:203

2D51 Photoelectric Detector Specifications

Architectural/Engineering Specifications

The air duct smoke detector shall be a System Sensor model 2D51 Series Smoke detector listed to UL 268A specifically for use in air handling systems when used in conjunction with the B210LP base. The detector shall operate at air velocities up to 4,000 feet per minute. It shall be capable of local testing using a magnet test on the 2D51 or using a test/reset button on the D4P120 power board. It can also be remotely tested using the RTS151, RTS151KEY, RTS2 or RTS2-AOS connected to the D4P120 power board. It shall be capable of providing duct smoke detector status via the UL-listed APA151, RTS2 and RTS2-AOS Piezo Annunciators.

Physical Specifications

Size	2.0 inches H, 4.1 inches D
Weight	3.1 oz (88 g)
Operating Temperature Range	-4°F to 158°F (-20°C to 70°C)
Operating Humidity Range	10 to 95% relative humidity non-condensing

B210LP Plug-In Detector Base

Physical Specifications

Diameter	6.1 inches (155mm)
Mounting	4-inch (102 mm) square box with or without plaster ring; Minimum Depth - 1.5 inches (38 mm) 4-inch Octagon Box; Minimum Depth - 1.5 inches (38 mm) 31/2-inch Octagon Box; Minimum Depth - 1.5 inches (38 mm) Single Gang Box; Minimum Depth - 1.5 inches (38 mm)
Operating Temperature Range	Refer to applicable sensor Operating Temperature Range using the Base/Sensor Cross Reference Chart at systemsensor.com

D4P120 Power Board

Physical Specifications

Size:	7.66 inches (19.45 cm) Length; 4.98 inches (12.64 cm) Width; 2.29 inches (5.81 cm) Depth		
Operating Temperature Range:	-40° to 158°F (-40° to 70°C)		
Storage Temperature Range:	-40° to 158°F (-40° to 70°C)		
Operating Humidity Range:	0 to 95% relative humidity non-condensing		
Weight:	1 lb 3 oz		

Electrical Ratings

Power supply voltage:	20–29 VDC	24 VAC 50–60 Hz	120 VAC 50–60 Hz
Input capacitance:	270 µF max.	270 µF max.	N/A
Reset voltage:	3.0 VDC min.	2.0 VAC min.	10 VAC min.
Reset time: (with RTS451)	.03 to 0.3 sec.	.03 to 0.3 sec.	.03 to 0.3 sec.
Reset time: (by power down)	0.6 sec. max.	0.6 sec. max.	0.6 sec. max.
Power up time:	35 sec. max.	35 sec. max.	35 sec. max.
Alarm response time:	15 sec.	15 sec.	15 sec.
Sensitivity test:	See detector label	See detector label	See detector label

Current Requirements: (Using No Accessories)

Max. standby current:	21 mA @ 24 VDC	65 mA RMS @ 24 VAC 60 Hz	20 mA RMS @ 120 VAC 60 Hz
Max. alarm current:	65 mA @ 24 VDC	135 mA RMS @ 24 VAC 60 Hz	35 mA RMS @ 120 VAC 60 Hz

Contact Ratings

Alarm initiation contacts: (SPST)	2.0 A @ 30 VDC (resistive)
Alarm auxiliary contacts: (DPDT)	10 A @ 30 VDC (resistive); 10A @ 250 VAC (resistive); ½ HP @ 240 VAC ; ¼ HP @ 120 VAC

Note: Alarm auxiliary contacts shall not be connected to initiating circuits of control panels. Use the alarm initiation contact for this purpose.

Supervisory contacts: (SPDT) 2.0 A @ 30 VDC (resistive); 2.0 A @ 125 VAC (resistive)

Accessory Current Loads at 24 VDC

Device	Standby	Trouble	Alarm
APA151	12.5 mA	n/a	30 mA Max.
MHR/MHW	0 mA	n/a	29 mA Max.
RA100Z	0 mA	n/a	12 mA Max.
RTS151/RTS151KEY	0 mA/12 mA	n/a	12 mA Max.
RTS2/RTS2-AOS	3.0 mA max	16 mA Max.	with strobe: 55 mA max; without strobe 30 mA max

Note: Any combination of accessories may be used such that the given accessory loads are: 110 mA or less at the Aux output, and 50 mA or less at the Alarm output.

B210LP Typical Wiring Diagrams

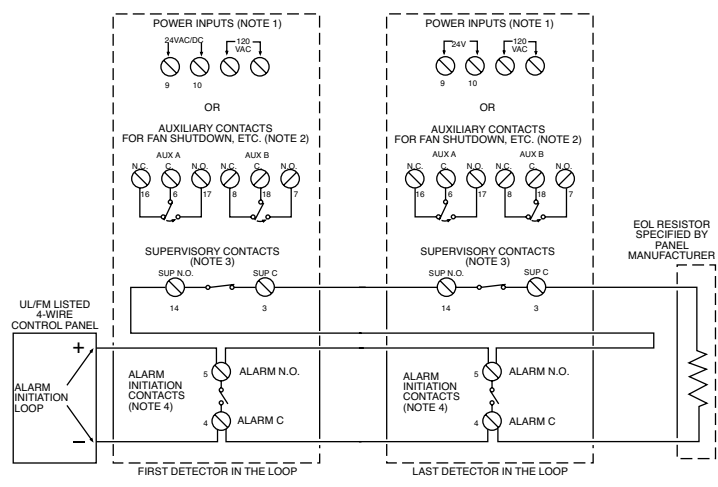
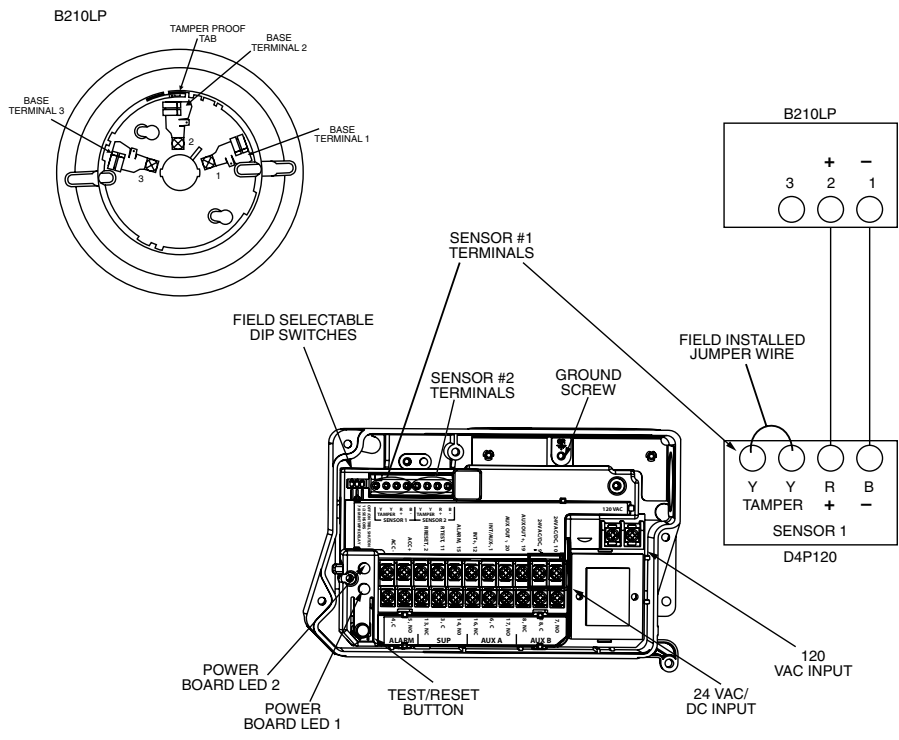

NOTE 1: 24V Power Inputs accept a non-polarized 24 VDC or 24 VAC 50-60Hz. 120 VAC Power Inputs accept only 120 VAC 50-60 Hz. Connect power source to appropriate terminals of each detector. See specifications for additional power supply information.

NOTE 2: Auxiliary contacts shown in standby position. Contacts switch during alarm as indicated by arrows. Auxiliary contacts are not to be used for connection to the control panel. See specifications for contact ratings.

NOTE 3: Supervisory contacts shown in standby position. Open contacts indicate a trouble condition to the panel. See specifications for contact ratings.

NOTE 4: Alarm Initiation contacts shown in standby position. Closed contacts indicate an alarm condition to the panel. See specifications for contact ratings.

*Please refer to the corresponding installation manual for detailed installation instructions and accessory wiring diagrams.

Accessories

System Sensor provides system flexibility with a variety of accessories, including two remote test stations and several different means of visible and audible system annunciation. As with our duct smoke detectors, all duct smoke detector accessories are UL listed.



RTS151 UL S4011



RTS151KEY UL S2522



APA151 UL S4011



RTS2-AOS UL S2522



RA100Z UL S2522



MHW UL S4011



AOS



Top Mount in Ventilation Shaft



D4P120 Power Board

Ordering Information

Part No.	Description
2D51	Low-profile photoelectric plug-in detector (order the base listed below)
B210LP	120 VAC detector base
D4P120	4-wire photoelectric power board component only, 24 VAC/DC, 120 VAC
RTS151	Remote test station
RTS151KEY	Remote test station with key lock
APA151	Remote annunciator with Piezo alarm
RTS2-AOS	Multi-signaling accessory
RA100Z	Remote annunciator alarm LED
MHW	Mini horn, white
AOS	Add-on strobe



3825 Ohio Avenue • St. Charles, IL 60174
 Phone: 800-SENSOR2 • Fax: 630-377-6495
www.systemsensor.com

©2012 System Sensor.
 Product specifications subject to change without notice. Visit systemsensor.com
 for current product information, including the latest version of this data sheet.
 HVDS00302 • 1/12