



Magic Touch

Super Elite Technology Co., Ltd.

ISSUE NO : 2K13AA042

DATE : 03/27/2013

Projected Capacitive

Touch Panel Specification

APPROVAL BY	CHECKED BY	REPORTED BY
Cheng	Jason	Angus

ISSUE BY :

SUPER ELITE TECHNOLOGY CO., LTD.

**No.21 SHING GONG ROAD, YUNG KANG
INDUSTRIAL DISTRICT, TAIWAN R.O.C.**

TEL: 886-6-2314706

FAX: 886-6-2314788

<http://www.magictouch.com.tw>

E-mail: superelite@magictouch.com.tw

		Touch Panel Specification	ISSUE NO	2K13AA042	
SET	Index		Page	1	
<p> 1. Suitability〔適用〕 2. Application〔應用〕 3. Specification〔規格〕 3.1 Structure 3.2 Touch Function 3.3 Operation Temperature and humidity〔操作溫度及溼度〕 3.4 Storage Temperature and humidity〔儲存溫度及溼度〕 3.5 Control IC 4. Shape and Dimension〔外型尺寸〕 5. Optical Characteristics〔光學特性〕 Total Light Transmittance〔全光線透過率〕 6. Electrical Properties〔電氣特性〕 7. Mechanical Properties〔機械特性〕 7.1 Input Mode 7.2 FPC Peeling Strength〔FPC 剝離強度〕 7.3 FPC Bending Strength〔FPC 耐屈折性〕 8. Environment Test〔環境測試〕 8.1 High Temperature Test〔高溫測試〕 8.2 Low Temperature Test〔低溫測試〕 8.3 Temperature and Humidity Test〔恆溫恆溼測試〕 8.4 Heat cycle〔冷熱循環測試〕 9. Appearance Inspection Standard〔外觀標準〕 9.1 Inspection condition〔檢驗方法〕 9.2 Inspection Standard〔檢驗基準〕 9.3 Glass Flaw〔玻璃瑕疵〕 10. Packing Detail〔包裝細節〕 11. Others〔其它〕 </p>					
AMEND NO		SUPER ELITE TECHNOLOGY CO., LTD	APPROVAL BY	CHECK BY	PREPARE BY
AMEND DATE					
PUBLISH DATE	03/27/2013		Cheng	Jason	Angus

		Touch Panel Specification	ISSUE NO	2K13AA042	
SET	Apply To Specification		Page	2	
<p>1. Suitability [適用] This specification is for projected capacitive touch panel. 本規格適用於投射式電容觸控面板。</p> <p>2. Application [應用] The touch panels used as the input devices for general electric appliances and OA equipment. 觸控面板這類型的輸入裝置，在一般電子產品及 OA 設備上廣泛的被使用。</p> <p>3. Specification [規格]</p> <p>3.1 Structure:</p> <p><input type="checkbox"/> Cover Glass + Film +Film <input type="checkbox"/> Film +Film <input type="checkbox"/> Cover Glass +Film</p> <p>3.2 Touch Function: <input type="checkbox"/> 2 Finger <input type="checkbox"/> 4 Finger</p> <p>3.3 Operation Temperature and humidity [操作溫度及溼度] -20°C to 70°C, <90%RH (Non-condensing) [沒有結露]</p> <p>3.4 Storage Temperature and humidity [儲存溫度及溼度] -20°C to 70°C, <90%RH (Non-condensing) [沒有結露]</p> <p>3.5 Control IC :</p> <p>3.5.1 EETI IC-EXC7920+EX5960+EX5418 or IC-EXC7200+EX5404</p> <p>3.5.2 IC on FPC</p> <p>Regards the IC specification, please refer the IC data sheet from supplier.</p> <p>4. Shape and Dimension [外型尺寸] Please refer the last page of this specification. [請參考最後一頁]</p>					
AMEND NO		SUPER ELITE TECHNOLOGY CO., LTD	APPROVAL BY	CHECK BY	PREPARE BY
AMEND DATE			Cheng	Jason	Angus
PUBLISH DATE	03/27/2013				

8. Environment Test [環境測試]

以下環境測試針對 G/F/F or G/F 成品測試 , Film /Film TYPE 不列入測試項目.

8.1. High Temperature Test [高溫測試]

after putting panels at 70°C for 120 hours, then leaving for 24 hours at room temperature.

The requirements in 6.1 , 6.2 , 6.3 shall be satisfied.

[放置在 70°C 環境下 120 小時後 , 需符合 6.1 , 6.2 , 6.3 規格 , 各項測試需放置室溫下 24 小時後測試]

8.2. Low Temperature Test [低溫測試]

after putting panels at -20°C for 120 hours, then leaving for 24 hours at room temperature.

The requirements in 6.1 , 6.2 , 6.3 shall be satisfied.

[放置在 -20°C 環境下 120 小時後 , 需符合 6.1 , 6.2 , 6.3 規格 , 各項測試需放置室溫下 24 小時後測試]

8.3. Temperature and Humidity Test [恆溫恆溼測試]

after putting panels at 60°C, 90%RH for 120 hours, then leaving for 24 hours at room temperature.

The requirements in 6.1 , 6.2 , 6.3 shall be satisfied.

[放置在 60°C, 90%RH 環境下 120 小時後 , 需符合 6.1 , 6.2 , 6.3 規格 , 各項測試需放置室溫下 24 小時後測試]

8.4 Heat cycle [冷熱循環測試]

after putting panels at the condition of -20°C for 30 minutes and then 70°C 85%RH for 30 minutes and this process is repeated by 10 cycles , then leaving for 24 hours at room temperature.

The requirements in 6.1 , 6.2 , 6.3 shall be satisfied.

[放置於 -20°C 之環境中持續 30 分鐘 , 再將溫度提升為 70°C 持續 30 分鐘 , 此為 1 Cycle , 持續 10 Cycle 測試 , 需符合 6.1 , 6.2 , 6.3 規格。(其中溫升及溫降各為 30 分鐘)]

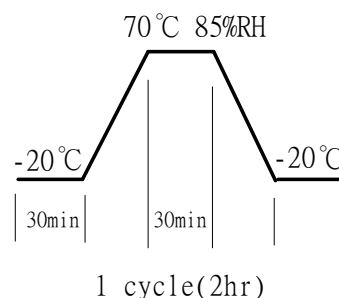

AMEND NO		SUPER ELITE TECHNOLOGY CO., LTD	APPROVAL BY	CHECK BY	PREPARE BY
AMEND DATE			Cheng	Jason	Angus
PUBLISH DATE	03/27/2013				

Touch Panel Specification

ISSUE NO

2K13AA042

SET

Appearance Inspection Standard

Page

5

9. Appearance [外觀標準]

9.1 Inspection condition [檢驗方法]

(A) The lightness of place: 500~800 LUX [光源在 500~800 流明]

(B) The distance of eyeshot: 30 CM (The panel must be checked under the light transparency condition.) [眼睛距離 30 公分]

(C) The angle of eyeshot: >60° [角度 >60°]

(D) Inspection time: 10 sec [檢驗時間: 10 秒]

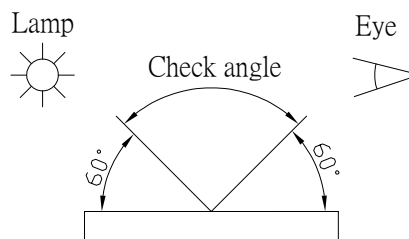

9.2 Inspection Standard [檢驗基準]

9.2.1 印刷區判定 (Film /Film TYPE 此項忽略不計)

Items [項目]	Specifications Explain [規格說明]	
1. 印刷區 白點/異色點	$D \leq 0.35 \text{ mm}$	允許
	$0.35 \text{ mm} < D \leq 0.5 \text{ mm}$	允許 3 個/間距 5mm
	$0.5 \text{ mm} < D$	不允許
2. 漏光(針孔)	$D \leq 0.2 \text{ mm}$	允許
	$D > 0.2 \text{ mm}$	不允許
3. 無感刮傷	$W \leq 0.075 \text{ mm}$	允許
	$0.075 \text{ mm} < W \leq 0.1 \text{ mm}$ and $L \leq 8.0 \text{ mm}$	允許 4 個/間距 5mm
	$0.1 \text{ mm} < W \leq 0.15 \text{ mm}$ and $L \leq 8.0 \text{ mm}$	允許 2 個/間距 5mm
	$0.15 \text{ mm} < W$ and $L \leq 8.0 \text{ mm}$	不允許

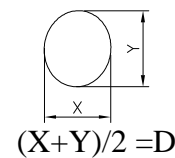

L : Length [長度], W : Width [寬度], D: Average Diameter [平均直徑]

AMEND NO		SUPER ELITE TECHNOLOGY CO., LTD	APPROVAL BY	CHECK BY	PREPARE BY
AMEND DATE			Cheng	Jason	Angus
PUBLISH DATE	03/27/2013				

Touch Panel Specification

ISSUE NO

2K13AA042

SET

Appearance Inspection Standard

Page

6

9.2.2 動作區判定

外觀檢測範圍：SENSOR AA 區內縮 2mm 開始計算。

Items [項目]	Specifications Explain [規格說明]	
2. 動作區 白點/異色點	$D \leq 0.35 \text{ mm}$	允許
	$0.35 \text{ mm} < D \leq 0.6 \text{ mm}$	允許 4 個/間距 5mm
	$0.6 \text{ mm} < D$	不允許
2.凹痕/氣泡/魚眼	$D \leq 0.1 \text{ mm}$	允許
	$0.1 \text{ mm} < D \leq 0.2 \text{ mm}$	允許 3 個/間距 5mm
	$0.2 \text{ mm} < D \leq 0.3 \text{ mm}$	允許 2 個/間距 5mm
	$0.3 \text{ mm} < D \leq 0.6 \text{ mm}$	允許 1 個/間距 5mm
	$D > 0.6 \text{ mm}$	不允許
3.線狀異物	$W \leq 0.075 \text{ mm}$	允許
	$0.075 \text{ mm} < W \leq 0.1 \text{ mm}$ and $L \leq 20.0 \text{ mm}$	允許 4 個/間距 5mm
	$0.1 \text{ mm} < W \leq 0.15 \text{ mm}$ and $L \leq 20.0 \text{ mm}$	允許 2 個/間距 5mm
	$0.15 \text{ mm} < W$ and $L \leq 20.0 \text{ mm}$	不允許
4. 刮傷	$W \leq 0.075 \text{ mm}$	允許
	$0.075 \text{ mm} < W \leq 0.1 \text{ mm}$ and $L \leq 20.0 \text{ mm}$	允許 4 個/間距 5mm
	$0.1 \text{ mm} < W \leq 0.15 \text{ mm}$ and $L \leq 20.0 \text{ mm}$	允許 2 個/間距 5mm
	$0.15 \text{ mm} < W$ and $L \leq 20.0 \text{ mm}$	不允許

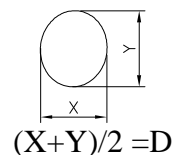

L : Length [長度], W : Width [寬度], D: Average Diameter [平均直徑]

AMEND NO		SUPER ELITE TECHNOLOGY CO., LTD	APPROVAL BY	CHECK BY	PREPARE BY
AMEND DATE					
PUBLISH DATE	03/27/2013		Cheng	Jason	Angus

Touch Panel Specification

ISSUE NO

2K13AA042

SET

Appearance Inspection Standard

Page

7

9.3 Glass Flaw [玻璃瑕疵] (Film /Film TYPE 此項忽略不計)

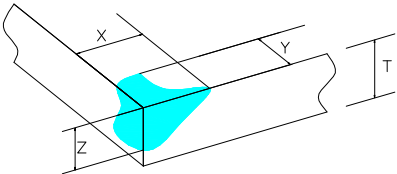
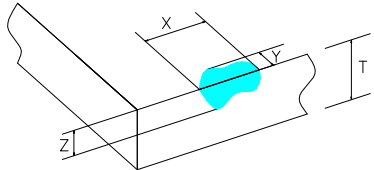
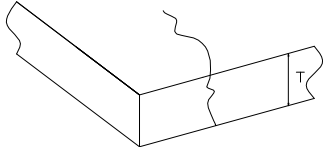
Items [項目]	Specifications Explain [規格說明]	
Glass Fragment [玻璃破片]	1. Corner Fragment [角落破片] 	$X \leq 3.0\text{mm}$ $Y \leq 3.0\text{mm}$ $Z \leq T$
	2. Edge Fragment [邊緣破片] 	$X \leq 3.0\text{mm}$ $Y \leq 3.0\text{mm}$ $Z \leq T$
	3. Progressive Fragment [線段的破片] 	None allowed [不允許]

note [註]: X: Wide [寬], Y: length [長], T: Glass thickness [玻璃厚度]。

AMEND NO		SUPER ELITE TECHNOLOGY CO., LTD	APPROVAL BY	CHECK BY	PREPARE BY
AMEND DATE			Cheng	Jason	Angus
PUBLISH DATE	03/27/2013				

		Touch Panel Specification		ISSUE NO	2K13AA042	
SET	Packing & Others			Page	8	
<p>10. Packing Detail [包裝細節]</p> <p>10.1 Packing: [包裝] Dirt adhering is not allowed. Pack with paper carton as well as pay attention to the safety of outside package. [不可有髒東西附著，使用紙盒包裝，並注意包裝外箱之安全事項。]</p> <p>10.2 Delivery: [運送] For Avoiding the badly affect to the product quality, shouldn't delivery in the situation of high humidity and unusually high or low temperature. [惡劣地環境會影響品質，避免在高溫、高濕環境條件下做納入工作。]</p> <p>11. Others [其它]</p> <p>1.) Since this is glass product, please watch out for the safety and keep it carefully as well. 2.) After panel testing ok, if it is unusual by setting or wrong using, it doesn't belong to assurance range。 3.) After this Specification is approved, it couldn't have any random changes。 4.) After receiving the products, please examine all in two weeks for your quality certification. [因本產品為玻璃製品，請注意安全及小心存放。] [本產品經檢測為良品後，因安裝或使用不當，而造成異常，不在保證範圍內。] [本承認書經承認後，不得隨意變更。] [收貨 2 週內無回覆,表示產品無問題，QC 允收。]</p> <p>5.) 產品結構選擇 Film +Film Type 時,請於保護膜未撕起前,檢測電氣功能, 保護膜撕起 or 貼合後，不在保證範圍內。</p> <p>12. This panel provides quality assurances that are listed as above。 [本產品提供如上所述的品質保證。]</p>						
AMEND NO		SUPER ELITE TECHNOLOGY CO., LTD		APPROVAL BY	CHECK BY	PREPARE BY
AMEND DATE				Cheng	Jason	Angus
PUBLISH DATE	03/27/2013					

