

Hi-Rel NPN bipolar transistor 80 V, 1 A

Datasheet — production data

Features

BV_{CEO}	80 V
I_C (max)	1 A
H_{FE} at 10 V - 150 mA	> 100
Operating temperature range	-65°C to +200°C

- Hi-Rel NPN bipolar transistor
- Linear gain characteristics
- ESCC qualified
- European preferred part list - EPPL
- Radiation level: lot specific total dose contact marketing for specified level

Description

The 2N3019HR is a silicon planar epitaxial NPN transistor in a TO-39 package. It is specifically designed for aerospace Hi-Rel applications, and ESCC qualified in accordance with the 5201-003 specification. In case of discrepancies between this datasheet and ESCC detailed specification, the latter prevails.

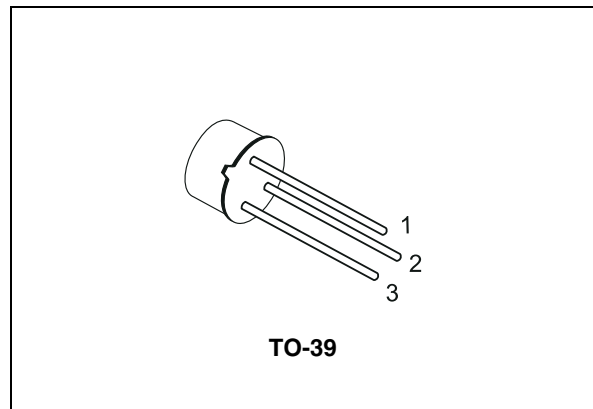

Figure 1. Internal schematic diagram

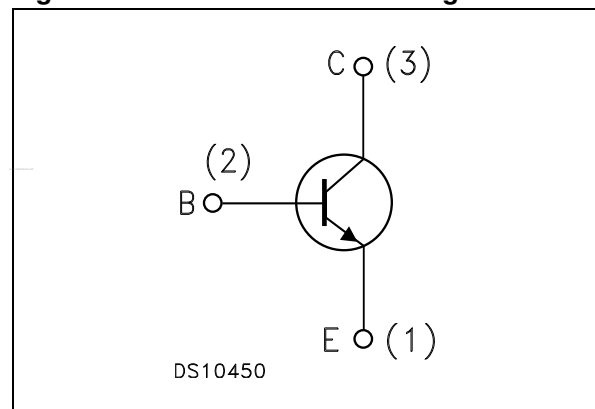

Table 1. Device summary

Order codes	Package	Lead finish	Marking	Type	EPPL	Packaging
2N3019HR	TO-39	Gold Solder Dip	520101103 520101104	ESCC Flight	Yes	Strip pack

1 Electrical ratings

Table 2. Absolute maximum ratings

Symbol	Parameter	Value	Unit
V_{CBO}	Collector-base voltage ($I_E = 0$)	140	V
V_{CEO}	Collector-emitter voltage ($I_B = 0$)	80	V
V_{EBO}	Emitter-base voltage ($I_C = 0$)	7	V
I_C	Collector current	1	A
P_{TOT}	Total dissipation at $T_{amb} \leq 25\text{ °C}$	0.8	W
	Total dissipation at $T_c \leq 25\text{ °C}$	5	W
T_{STG}	Storage temperature	-65 to 200	°C
T_J	Max. operating junction temperature	200	°C

Table 3. Thermal data

Symbol	Parameter	Value	Unit
R_{thJC}	Thermal resistance junction-case	max 35	°C/W
R_{thJA}	Thermal resistance junction-ambient	max 218	°C/W

2 Electrical characteristics

$T_{\text{case}} = 25\text{ °C}$ unless otherwise specified

Table 4. Electrical characteristics

Symbol	Parameter	Test conditions	Min.	Typ.	Max.	Unit
I_{CES}	Collector cut-off current ($I_{\text{E}} = 0$)	$V_{\text{CB}} = 90\text{ V}$ $V_{\text{CB}} = 90\text{ V}, T_{\text{amb}} = 150\text{ °C}$		-	10 10	nA μA
I_{EBO}	Emitter cut-off current ($I_{\text{C}} = 0$)	$V_{\text{EB}} = 5\text{ V}$		-	10	nA
$V_{(\text{BR})\text{CBO}}$	Collector-base breakdown voltage ($I_{\text{E}} = 0$)	$I_{\text{C}} = 100\text{ }\mu\text{A}$	140	-		V
$V_{(\text{BR})\text{CEO}}^{(1)}$	Collector-emitter breakdown voltage ($I_{\text{B}} = 0$)	$I_{\text{C}} = 30\text{ mA}$	80	-		V
$V_{(\text{BR})\text{EBO}}$	Emitter-base breakdown voltage ($I_{\text{C}} = 0$)	$I_{\text{E}} = 100\text{ }\mu\text{A}$	7	-		V
$V_{\text{CE(sat)}}^{(1)}$	Collector-emitter saturation voltage	$I_{\text{C}} = 150\text{ mA}, I_{\text{B}} = 15\text{ mA}$ $I_{\text{C}} = 500\text{ mA}, I_{\text{B}} = 50\text{ mA}$		-	0.2 0.5	V V
$V_{\text{BE(sat)}}^{(1)}$	Base-emitter saturation voltage	$I_{\text{C}} = 150\text{ mA}, I_{\text{B}} = 15\text{ mA}$		-	1.1	V
$h_{\text{FE}}^{(1)}$	DC current gain	$I_{\text{C}} = 0.1\text{ mA}, V_{\text{CE}} = 10\text{ V}$ $I_{\text{C}} = 10\text{ mA}, V_{\text{CE}} = 10\text{ V}$ $I_{\text{C}} = 150\text{ mA}, V_{\text{CE}} = 10\text{ V}$ $I_{\text{C}} = 500\text{ mA}, V_{\text{CE}} = 10\text{ V}$ $I_{\text{C}} = 1\text{ A}, V_{\text{CE}} = 10\text{ V}$ $I_{\text{C}} = 150\text{ mA}, V_{\text{CE}} = 10\text{ V}$ $T_{\text{amb}} = -65\text{ °C}$	50 90 100 50 15 40	-	200 300 200	
h_{fe}	Small signal current gain	$V_{\text{CE}} = 10\text{ V}, I_{\text{C}} = 50\text{ mA}$ $f = 20\text{ MHz}$	5	-	20	
h_{fe}	Small signal short circuit forward current transfer ratio	$V_{\text{CE}} = 5\text{ V}, I_{\text{C}} = 1\text{ mA}$	80	-	400	
C_{CBO}	Output capacitance ($I_{\text{E}} = 0$)	$V_{\text{CB}} = 10\text{ V}, f = 1\text{ MHz}$		-	12	pF
C_{IBO}	Input capacitance ($I_{\text{C}} = 0$)	$V_{\text{EB}} = 0.5\text{ V}, f = 1\text{ MHz}$		-	60	pF
NF	Noise figure	$V_{\text{CE}} = 10\text{ V}, I_{\text{C}} = 100\text{ }\mu\text{A}$ $R_{\text{G}} = 1\text{ k}\Omega$ Bandwidth = 200 Hz		-	4	dB
$t_{\text{C(CB)}}$	Collector- base constant time	$V_{\text{CE}} = 10\text{ V}, I_{\text{C}} = 10\text{ mA}$ $f = 79.8\text{ MHz}$		-	400	ps
$t_{\text{on}} + t_{\text{off}}$	Pulse response	$V_{\text{CC}} = 20\text{ V}$, see Figure 8		-	30	ns

1. Pulsed duration = 300 μs , duty cycle $\leq 2\%$

2.1 Electrical characteristics (curves)

Figure 2. DC current gain ($V_{CE}=1\text{ V}$)

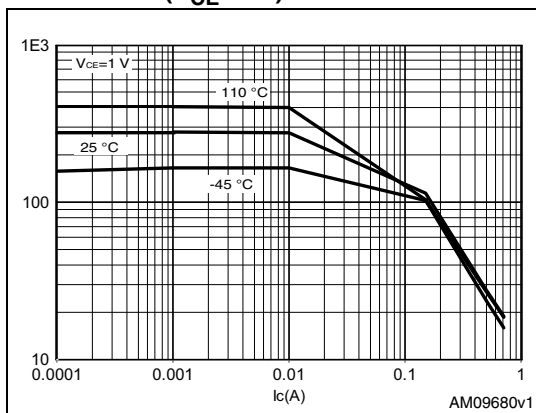

Figure 3. DC current gain ($V_{CE}=10\text{ V}$)

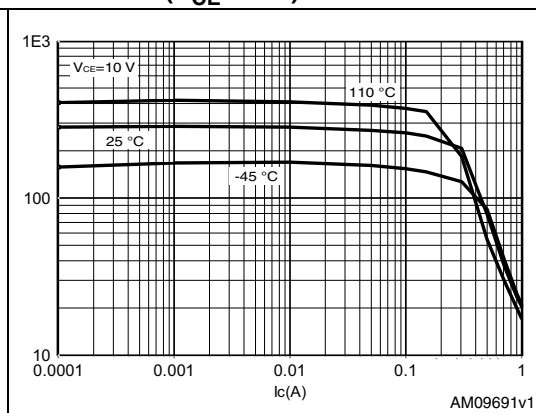

Figure 4. Collector emitter saturation voltage

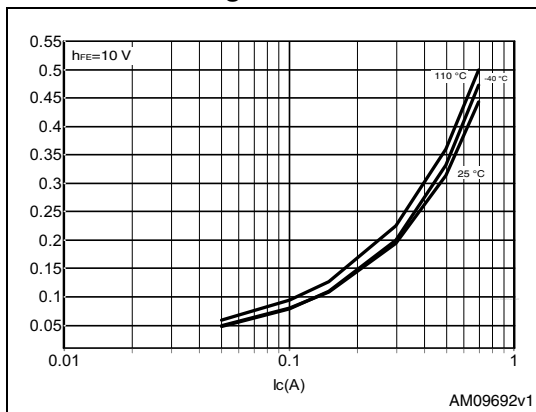
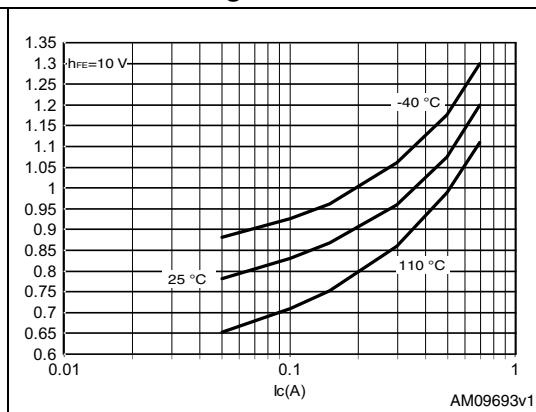
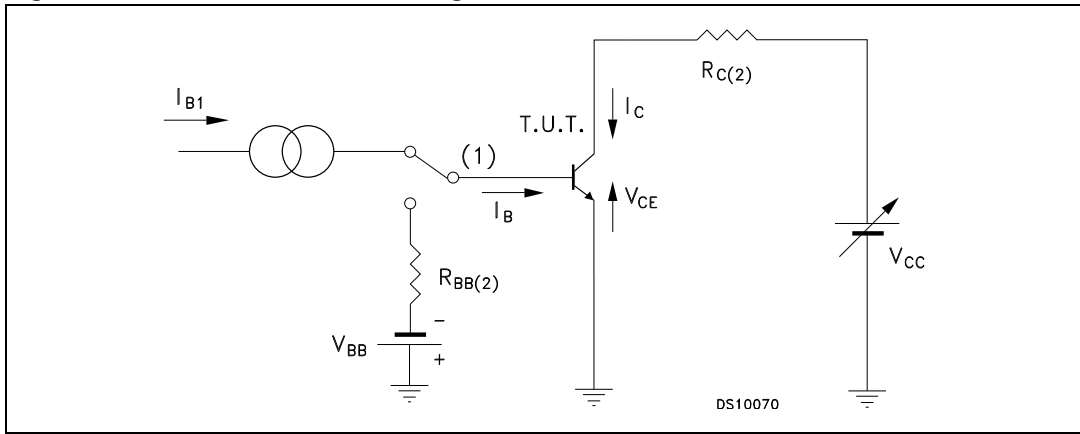

Figure 5. Base emitter saturation voltage



2.2 Test circuits

Figure 6. Resistive load switching test circuit



1. Fast electronic switch
2. Non-inductive resistor

Figure 7. Circuit for electrical measurement

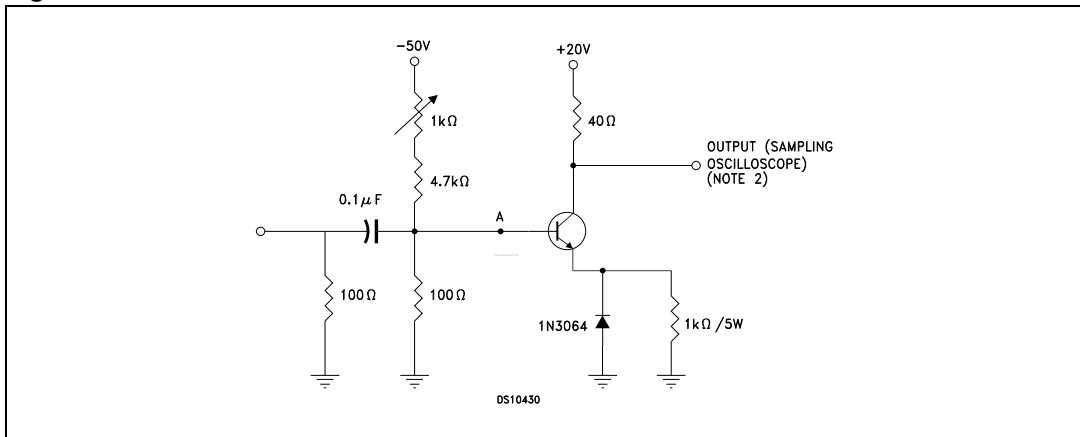
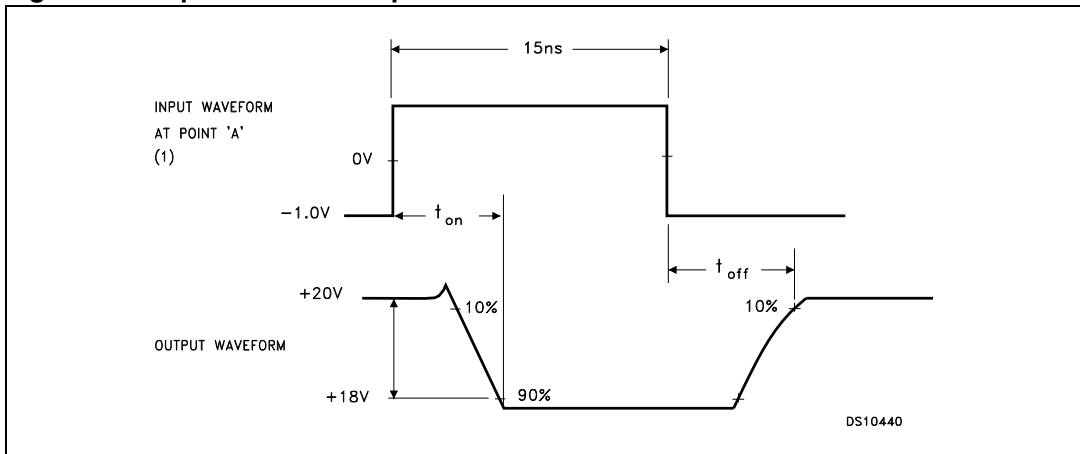

Figure 8. Input waveform at point "A"



1. $t_r \leq 2$ ns, duty cycle $\leq 5\%$, $Z_{IN} = 50 \Omega$
2. Sampling oscilloscope: $Z_{IN} \geq 100 \text{ k}\Omega$, $C_{IN} \leq 12 \text{ pF}$, $t_r \leq 5$ ns

3 Package mechanical data

In order to meet environmental requirements, ST offers these devices in different grades of ECOPACK[®] packages, depending on their level of environmental compliance. ECOPACK[®] specifications, grade definitions and product status are available at: www.st.com. ECOPACK[®] is an ST trademark.

Table 5. TO-39 mechanical data

Dim.	mm		
	Min.	Typ.	Max.
A	-	12.70	14.20
B		0.40	0.49
C		0.58	0.74
D		6.00	6.40
E		8.15	8.25
F		9.10	9.20
G		4.93	5.23
H		0.85	0.95
I		0.75	0.85
L		42°	48°

Figure 9. TO-39 drawing

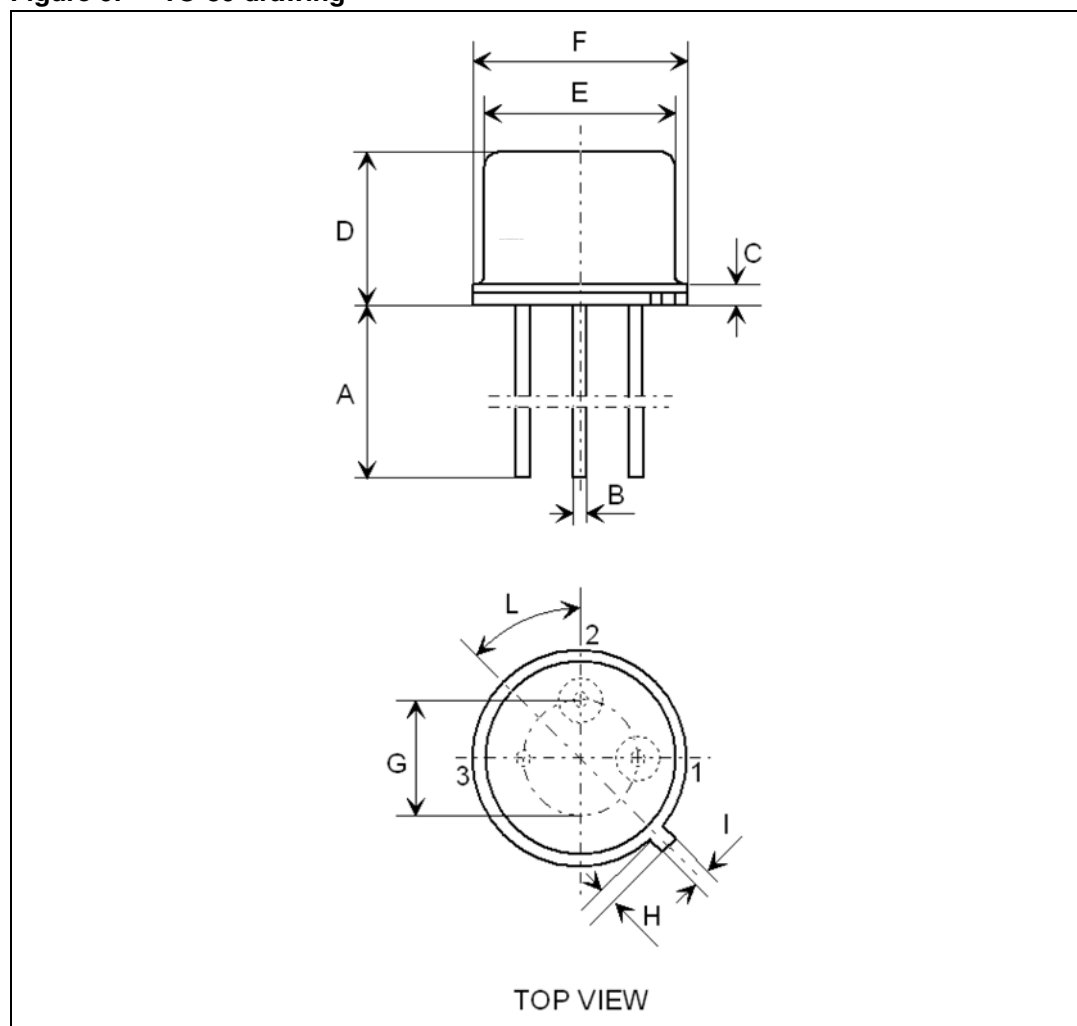

4 Revision history

Table 6. Document revision history

Date	Revision	Changes
09-Feb-2009	1	Initial release
07-Jan-2010	2	Modified Table 1 on page 1
05-Oct-2012	3	Minor text changes. Section 2.1: Electrical characteristics (curves) has been added.

Please Read Carefully:

Information in this document is provided solely in connection with ST products. STMicroelectronics NV and its subsidiaries ("ST") reserve the right to make changes, corrections, modifications or improvements, to this document, and the products and services described herein at any time, without notice.

All ST products are sold pursuant to ST's terms and conditions of sale.

Purchasers are solely responsible for the choice, selection and use of the ST products and services described herein, and ST assumes no liability whatsoever relating to the choice, selection or use of the ST products and services described herein.

No license, express or implied, by estoppel or otherwise, to any intellectual property rights is granted under this document. If any part of this document refers to any third party products or services it shall not be deemed a license grant by ST for the use of such third party products or services, or any intellectual property contained therein or considered as a warranty covering the use in any manner whatsoever of such third party products or services or any intellectual property contained therein.

UNLESS OTHERWISE SET FORTH IN ST'S TERMS AND CONDITIONS OF SALE ST DISCLAIMS ANY EXPRESS OR IMPLIED WARRANTY WITH RESPECT TO THE USE AND/OR SALE OF ST PRODUCTS INCLUDING WITHOUT LIMITATION IMPLIED WARRANTIES OF MERCHANTABILITY, FITNESS FOR A PARTICULAR PURPOSE (AND THEIR EQUIVALENTS UNDER THE LAWS OF ANY JURISDICTION), OR INFRINGEMENT OF ANY PATENT, COPYRIGHT OR OTHER INTELLECTUAL PROPERTY RIGHT.

UNLESS EXPRESSLY APPROVED IN WRITING BY TWO AUTHORIZED ST REPRESENTATIVES, ST PRODUCTS ARE NOT RECOMMENDED, AUTHORIZED OR WARRANTED FOR USE IN MILITARY, AIR CRAFT, SPACE, LIFE SAVING, OR LIFE SUSTAINING APPLICATIONS, NOR IN PRODUCTS OR SYSTEMS WHERE FAILURE OR MALFUNCTION MAY RESULT IN PERSONAL INJURY, DEATH, OR SEVERE PROPERTY OR ENVIRONMENTAL DAMAGE. ST PRODUCTS WHICH ARE NOT SPECIFIED AS "AUTOMOTIVE GRADE" MAY ONLY BE USED IN AUTOMOTIVE APPLICATIONS AT USER'S OWN RISK.

Resale of ST products with provisions different from the statements and/or technical features set forth in this document shall immediately void any warranty granted by ST for the ST product or service described herein and shall not create or extend in any manner whatsoever, any liability of ST.

ST and the ST logo are trademarks or registered trademarks of ST in various countries.

Information in this document supersedes and replaces all information previously supplied.

The ST logo is a registered trademark of STMicroelectronics. All other names are the property of their respective owners.

© 2012 STMicroelectronics - All rights reserved

STMicroelectronics group of companies

Australia - Belgium - Brazil - Canada - China - Czech Republic - Finland - France - Germany - Hong Kong - India - Israel - Italy - Japan - Malaysia - Malta - Morocco - Philippines - Singapore - Spain - Sweden - Switzerland - United Kingdom - United States of America

www.st.com

