



NPN 2N3227

SILICON ANNULAR TRANSISTORS

The 2N3227 are silicon NPN silicon annular transistors for low-current, high-speed switching applications.
They are mounted in Jedec TO-18 metal.

ABSOLUTE MAXIMUM RATINGS

Symbol	Ratings	Value	Unit
V_{CBO}	Collector-Base Voltage	40	V
V_{CEO}	Collector-Emitter Voltage	20	V
V_{EBO}	Emitter-Base Voltage	6	V
V_{CES}	Collector-Emitter Voltage	40	V
I_C (peak)	Collector Current	500	mA
P_D	TOTAL Device Dissipation Ambient Temperature Derating Factor Above	@ $T_C = 25^\circ$	0.36 Watts
			2.06 mW/°C
P_D	TOTAL Device Dissipation Case Temperature Derating Factor Above	@ $T_C = 25^\circ$	1.2 Watts
			6.85 mW/°C
T_J	Junction Temperature	+200	°C
T_{Stg}	Storage Temperature range	-65 to +200	

NPN 2N3227

ELECTRICAL CHARACTERISTICS

TC=25°C unless otherwise noted

Symbol	Ratings	Test Condition(s)	Min	Typ	Mx	Unit
I_{CBO}	Collector cut-off current	$I_E = 0 ; V_{CB} = 20V$	-	-	0.2	μA
		$I_E = 0 ; V_{CB} = 20V ; T_A = 150^\circ C$	-	-	50	
I_{CEX}	Collector cut-off current	$V_{CE} = 20V ; V_{EB(off)} = 3V$	-	-	0.2	
I_{BL}	Base cut-off current	$V_{CE} = 20V ; V_{EB(off)} = 3V$	-	-	0.5	
BV_{CBO}	Collector-Base Breakdown voltage	$I_C = 10 \mu A ; I_B = 0$	40	-	-	V
BV_{EBO}	Emitter-Base Breakdown voltage	$I_E = 10 \mu A ; I_C = 0$	6	-	-	V
BV_{CEO}	Collector-Emitter Breakdown voltage (1)	$I_C = 10 mA$	20	-	-	V
BV_{CES}	Collector-Emitter voltage	$I_C = 10 \mu A ; I_B = 0$	40	-	-	V

Symbol	Ratings	Test Condition(s)	Min	Typ	Mx	Unit
$V_{CE(SAT)}$	Collector-Emitter saturation Voltage (1)	$I_C=10\text{ mA}, I_B=1.0\text{ mA}$	-	-	0.25	V
		$I_C=100\text{ mA}, I_B=10\text{ mA}$	-	-	0.45	
$V_{BE(SAT)}$	Base-Emitter saturation Voltage (1)	$I_C=10\text{ mA}, I_B=1.0\text{ mA}$	-	-	0.85	V
		$I_C=100\text{ mA}, I_B=10\text{ mA}$	-	-	1.4	
h_{FE}	DC Current Gain	$V_{CE}=1.0\text{ V}, I_C=10\text{ mA}$	100	-	300	-
		$V_{CE}=1.0\text{ V}, I_C=10\text{ mA}, T_A=-55^\circ\text{C}$	40	-	-	
		$V_{CE}=1.0\text{ V}, I_C=100\text{ mA}$	30	-	-	
h_{fe}	Small Signal Current Gain	$V_{CE}=10\text{ V}, I_C=10\text{ mA}, f=100\text{ MHz}$	5	-	-	-
t_s	Storage time	$I_C = I_{B1} = I_{B2} = 10\text{ mA}$	-	-	13	ns
T_{off}	Turn-off time	$I_C=10\text{ mA}; I_{B1}=3\text{ mA}; I_{B2}=1.5\text{ mA}; V_{CC}=3.0\text{ V}$	-	-	18	
t_{on}	Turn-on time	$I_C=10\text{ mA}; I_{B1}=3\text{ mA}; V_{CC}=3.0\text{ V}; V_{EB(off)}=1.5\text{ V}$	-	-	12	
C_{ob}	Output Capacitance	$V_{CB}=5\text{ V}; I_E=0, f=140\text{ kHz}$	-	-	4.0	pF
C_{ib}	Input Capacitance	$V_{BE}=1\text{ V}; I_C=0, f=140\text{ kHz}$	-	-	4.0	pF

NPN 2N3227

MECHANICAL DATA CASE TO-18

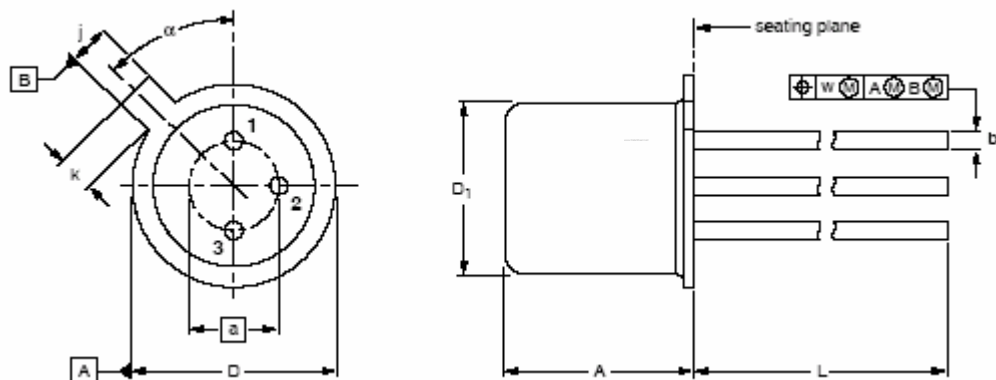

DIMENSIONS (millimetre dimensions are derived from the original inch dimensions)

UNIT	A	a	b	D	D ₁	j	k	L	w	α
mm	5.31 4.74	2.54	0.47 0.41	5.45 5.30	4.70 4.55	1.03 0.94	1.1 0.9	15.0 12.7	0.40	45°

Pin 1 :	Emitter
Pin 2 :	Base
Case :	Collector