

Silicon NPN Power Transistors

2N3441

DESCRIPTION

- With TO-66 package
- Continuous collector current- $I_C=3A$
- Power dissipation - $P_D=25W$ @ $T_C=25^\circ C$

APPLICATIONS

For use in general-purpose switching and Linear amplifier applications such as:

- Driver for high power outputs
- Series and shunt regulators
- Audio and servo amplifiers
- Solenoid and relay drivers
- Power switching circuits

PINNING (See Fig.2)

PIN	DESCRIPTION
1	Base
2	Emitter
3	Collector

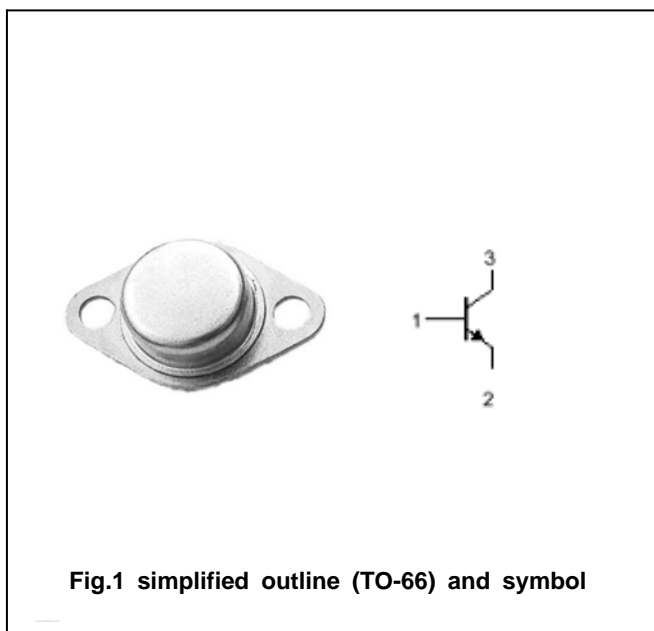

Fig.1 simplified outline (TO-66) and symbol

ABSOLUTE MAXIMUM RATINGS($T_a=25^\circ C$)

SYMBOL	PARAMETER	CONDITIONS	VALUE	UNIT
V_{CBO}	Collector-base voltage	Open emitter	160	V
V_{CEO}	Collector-emitter voltage	Open base	140	V
V_{EBO}	Emitter-base voltage	Open collector	7	V
I_C	Collector current		3	A
I_B	Base current		2	A
P_D	Total power dissipation	$T_C=25^\circ C$	25	W
T_j	Junction temperature		200	$^\circ C$
T_{stg}	Storage temperature		-65~200	$^\circ C$

THERMAL CHARACTERISTICS

SYMBOL	PARAMETER	MAX	UNIT
$R_{(th) jc}$	Thermal resistance junction to case	7.0	$^\circ C/W$

Silicon NPN Power Transistors

2N3441

CHARACTERISTICS

 $T_j=25^{\circ}\text{C}$ unless otherwise specified

SYMBOL	PARAMETER	CONDITIONS	MIN	TYP.	MAX	UNIT
$V_{CEO(SUS)}$	Collector-emitter sustaining voltage	$I_C=100\text{mA}$; $I_B=0$	140			V
$V_{CE(sat)}$	Collector-emitter saturation voltage	$I_C=2.7\text{A}$; $I_B=0.9\text{A}$			6.0	V
$V_{BE(on)}$	Base -emitter on voltage	$I_C=2.7\text{A}$; $V_{CE}=4\text{V}$			6.7	V
I_{CEX}	Collector cut-off current	$V_{CE}=140\text{V}$; $V_{BE(off)}=1.5\text{V}$ $V_{CE}=140\text{V}$; $V_{BE(off)}=1.5\text{V}$ $T_C=150^{\circ}\text{C}$			5.0 6.0	mA
I_{CEO}	Collector cut-off current	$V_{CE}=140\text{V}$; $I_B=0$			10	mA
I_{EBO}	Emitter cut-off current	$V_{EB}=7\text{V}$; $I_C=0$			1.0	mA
h_{FE-1}	DC current gain	$I_C=0.5\text{A}$; $V_{CE}=4\text{V}$	25		100	
h_{FE-2}	DC current gain	$I_C=2.7\text{A}$; $V_{CE}=4\text{V}$	5			

Silicon NPN Power Transistors

2N3441

PACKAGE OUTLINE

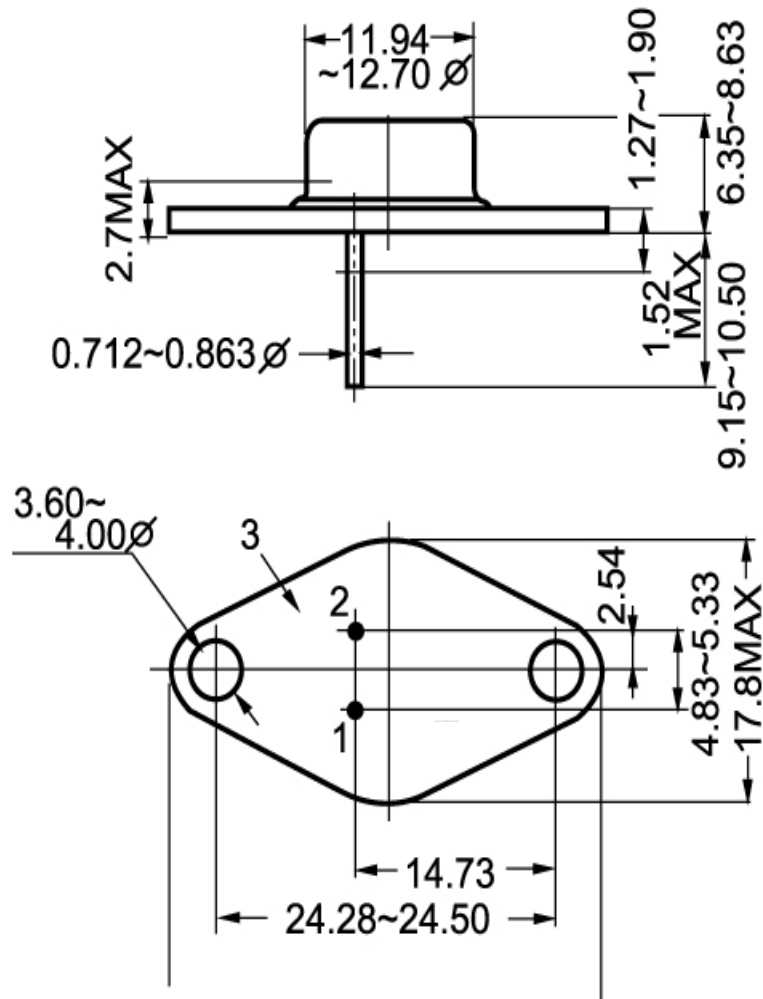

Fig.2 Outline dimensions