

## Silicon NPN Power Transistors

2N3446

## DESCRIPTION

- With TO-3 package
- Excellent safe operating area

## APPLICATIONS

- Designed for medium-switching and amplifier applications.

## PINNING

PIN	DESCRIPTION
1	Base
2	Emitter
3	Collector

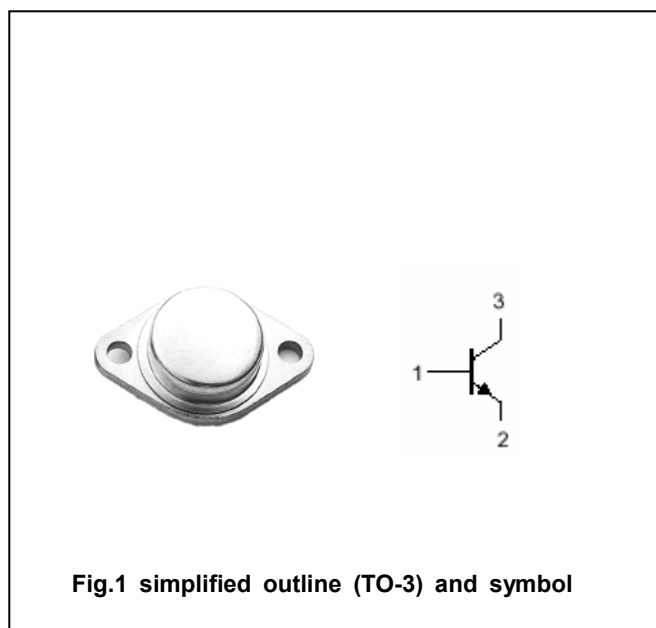

Fig.1 simplified outline (TO-3) and symbol

ABSOLUTE MAXIMUM RATINGS( $T_a=25^\circ\text{C}$ )

SYMBOL	PARAMETER	CONDITIONS	VALUE	UNIT
$V_{CBO}$	Collector-base voltage	Open emitter	100	V
$V_{CEO}$	Collector-emitter voltage	Open base	100	V
$V_{EBO}$	Emitter-base voltage	Open collector	7	V
$I_C$	Collector current		7.5	A
$P_C$	Collector power dissipation	$T_C=25^\circ\text{C}$	115	W
$T_j$	Junction temperature		150	$^\circ\text{C}$
$T_{stg}$	Storage temperature		-65~200	$^\circ\text{C}$

## THERMAL CHARACTERISTICS

SYMBOL	PARAMETER	VALUE	UNIT
$R_{(th)jc}$	Thermal resistance junction to case	1.17	$^\circ\text{C}/\text{W}$

## Silicon NPN Power Transistors

2N3446

## CHARACTERISTICS

T<sub>j</sub>=25 °C unless otherwise specified

SYMBOL	PARAMETER	CONDITIONS	MIN	TYP.	MAX	UNIT
V <sub>(BR)CEO</sub>	Collector-emitter breakdown voltage	I <sub>C</sub> =30mA ; I <sub>B</sub> =0	100			V
V <sub>CE(sat)-1</sub>	Collector-emitter saturation voltage	I <sub>C</sub> =3A; I <sub>B</sub> =0.3A			1.2	V
V <sub>CE(sat)-2</sub>	Collector-emitter saturation voltage	I <sub>C</sub> =7A; I <sub>B</sub> =1.5A			3.0	V
V <sub>BE(on)</sub>	Base-emitter on voltage	I <sub>C</sub> =3A ; V <sub>CE</sub> =5V			1.5	V
I <sub>CEO</sub>	Collector cut-off current	V <sub>CE</sub> =100V; I <sub>B</sub> =0			0.7	mA
I <sub>CBO</sub>	Collector cut-off current	V <sub>CB</sub> =100V; I <sub>E</sub> =0			0.1	mA
I <sub>EBO</sub>	Emitter cut-off current	V <sub>EB</sub> =7V; I <sub>C</sub> =0			0.1	mA
h <sub>FE-1</sub>	DC current gain	I <sub>C</sub> =3A ; V <sub>CE</sub> =5V	20		60	
h <sub>FE-2</sub>	DC current gain	I <sub>C</sub> =7A ; V <sub>CE</sub> =5V	4			

Silicon NPN Power Transistors

2N3446

PACKAGE OUTLINE

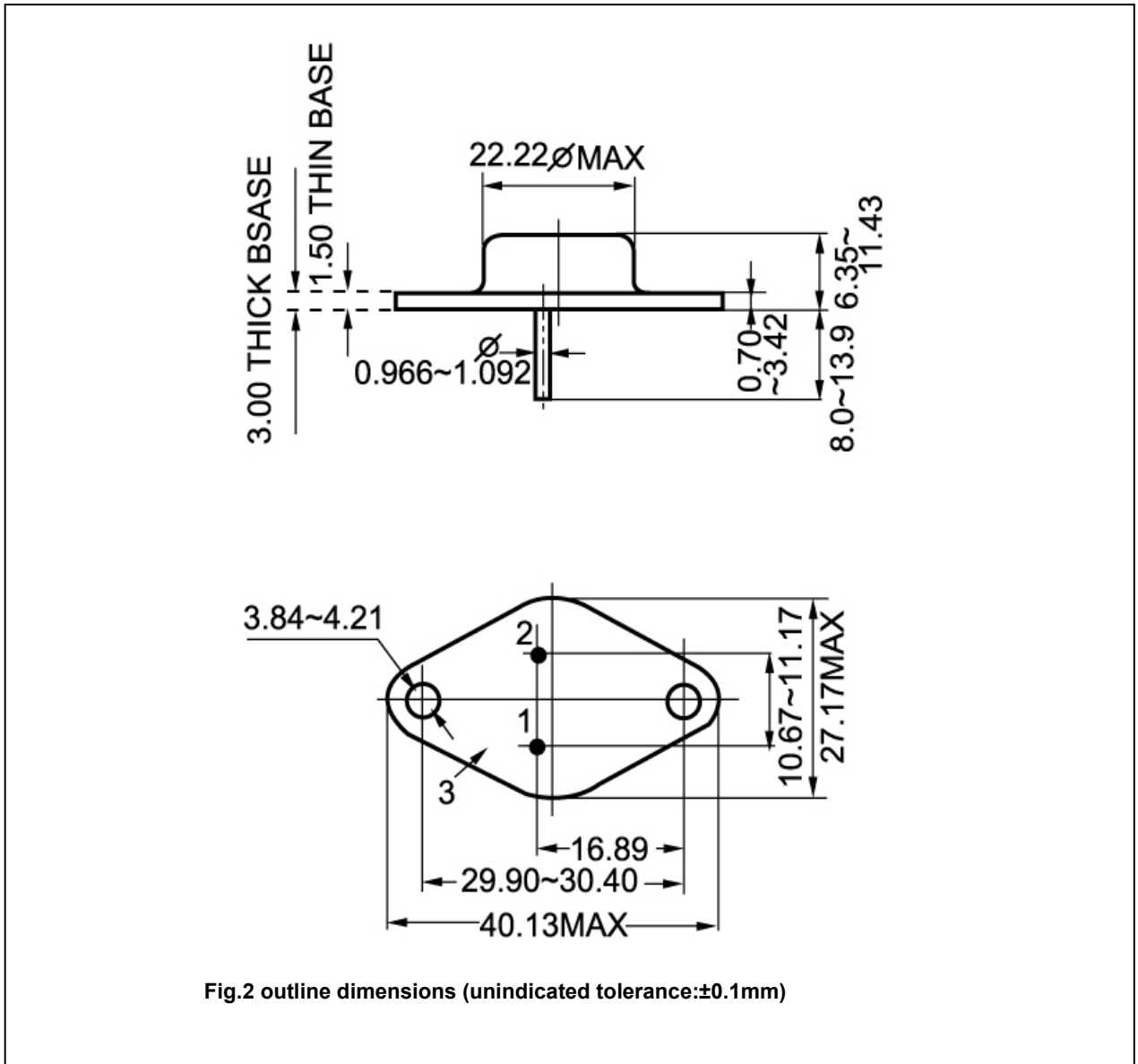

Fig.2 outline dimensions (unindicated tolerance:±0.1mm)