

# High Speed Switching Transistors

TYPE NO.	CASE	P <sub>D</sub> @T <sub>A</sub> = 25°C mW	BV <sub>CBO</sub> V	LV <sub>CEO</sub> V	BV <sub>EBO</sub> V	h <sub>FE</sub>		@ I <sub>C</sub> mA	V <sub>CE(sat)</sub> V	@ I <sub>C</sub> mA	t <sub>on</sub> ns	t <sub>off</sub> ns	f <sub>T</sub> MHz	C <sub>ob</sub> pF
						min	max							
<b>N P N</b>														
WA 9001	TO-106	250	40	15	4.5	40	120	10	0.25	10	12	18	400	4
WA 9002	TO-106	250	30	12	4.5	30	150	10	0.25	10	15	20	400	4
WA 9003	TO-106	250	18	12	4	25	200	10	0.25	10	15	20	400	4
WA 9021	TO-106	250	40	15	5	30	120	10	0.25	10	30	25	300	6
WA 9022	TO-106	250	25	12	4	30	—	10	0.4	10	50	70	300	6
WA 9001	TO-18	360	40	15	4.5	40	120	10	0.25	10	12	18	750	4
WA 9002	TO-18	360	30	12	4.5	30	150	10	0.25	10	15	20	750	4
WA 9003	TO-18	360	18	12	4	25	200	10	0.25	10	15	20	750	4
2N 706	TO-18	300	25	15	3	20	—	10	0.6	10	40	75	200	6
2N 708	TO-18	360	40	15	5	30	120	10	0.4	10	40	75	300	6
2N 744	TO-18	300	20	12	5	40	120	10	0.35	10	16	24	300	5
2N 753	TO-18	300	25	15	5	40	120	10	0.6	10	40	75	200	5
2N 834	TO-18	300	40	—	5	25	—	10	0.25	10	33	75	350	4
2N 914	TO-18	360	40	15	5	30	120	10	0.25	20	—	20	300	6
2N 2220	TO-18	500	60	30	5	20	60	150	0.4	150	35	285	250	8
2N 2221	TO-18	500	60	30	5	40	120	150	0.4	150	35	285	250	8
2N 2222	TO-18	500	60	30	5	100	300	150	0.4	150	35	285	250	8
2N 2222A	TO-18	500	75	40	6	100	300	150	0.3	150	35	285	250	8
2N 2243	TO-5	800	120	80	7	40	120	150	0.35	150	35	285	50	15
2N 2243A	TO-5	800	120	80	7	40	120	150	0.25	150	35	285	50	15
2N 2368	TO-18	360	40	15	4.5	20	60	10	0.25	10	12	15	400	4
2N 2369	TO-18	360	40	15	4.5	40	120	10	0.25	10	12	18	500	4
2N 2369A	TO-18	360	40	15	4.5	40	120	10	0.3	10	12	18	500	4
2N 3011	TO-18	360	30	12	5	30	120	10	0.2	10	15	20	400	4
2N 3014	TO-18	360	40	20	5	30	120	30	0.18	30	16	25	350	5
2N 3299	TO-5	800	60	30	5	40	120	150	0.22	150	60	150	250	8
2N 3300	TO-5	800	60	30	5	100	300	150	0.22	150	60	150	250	8
2N 3301	TO-18	360	60	30	5	40	120	150	0.22	150	60	150	250	8
2N 3302	TO-18	360	60	30	5	100	300	150	0.22	150	60	150	250	8
2N 3646	TO-106	200	40	15	5	30	120	30	0.2	30	—	18	350	5
2N 3903	TO-92A	310	60	40	6	50	150	10	0.2	10	70	225	250	4
2N 3904	TO-92A	310	60	40	6	100	300	10	0.2	10	70	250	300	4
2N 4274	TO-106	280	30	12	4.5	20	150	10	0.25	10	12	12	400	4
2N 4275	TO-106	280	40	15	4.5	20	150	10	0.25	10	12	12	400	4
2N 5134	TO-106	200	20	10	3.5	20	150	10	0.25	10	18	18	250	4
BSX 20	TO-18	360	40	15	4.5	40	120	10	0.3	10	12	18	500	4
BSX 21	TO-18	300	120	80	5	20	—	4	0.7	4	40	40	60	6
BSX 27	TO-18	300	15	6	4	25	125	10	0.38	30	12	12	600	3
BSY 26	TO-18	360	20	15	5	20	60	10	0.35	10	—	—	—	6
BSY 27	TO-18	360	20	15	—	40	120	10	0.35	10	—	—	—	6
BSY 39	TO-18	300	20	—	5	40	120	10	0.25	10	14	45	350	5
BSY 95	TO-18	300	20	15	5	50	200	10	0.35	10	—	—	200	8
<b>P N P</b>														
WA 0491	TO-106	250	30	20	5	30	120	30	0.15	10	25	35	500	4
WA 0492	TO-106	250	25	16	5	50	150	30	0.15	10	25	35	500	4
WA 0493	TO-106	250	15	12	5	30	150	30	0.25	10	60	90	500	6
WA 0491	TO-18	360	30	20	5	30	120	30	0.15	10	25	35	500	4
WA 0492	TO-18	360	25	16	5	50	150	30	0.15	10	25	35	500	4
WA 0493	TO-18	360	15	12	5	30	150	30	0.25	10	60	90	500	6
2N 3133	TO-5	600	50	35	4	40	120	150	0.6	150	75	150	200	10

## High Speed Switching Transistors

TYPE NO.	CASE	P <sub>D</sub> @T <sub>A</sub> =25°C mW	BV <sub>CEO</sub> V	LV <sub>CEO</sub> V	BV <sub>EBO</sub> V	h <sub>FE</sub>		I <sub>C</sub> mA	V <sub>CE(sat)</sub> V	I <sub>C</sub> mA	t <sub>on</sub> ns	t <sub>off</sub> ns	f <sub>T</sub> MHz	C <sub>ob</sub> pF
						min	max							
	<b>P N P</b>													
2N3134	TO-5	600	50	35	4	100	300	150	0.6	150	75	150	200	10
2N3135	TO-18	400	50	35	4	40	120	150	0.6	150	75	150	200	10
2N3136	TO-18	400	50	35	4	100	300	150	0.6	150	75	100	200	10
2N3248	TO-18	360	15	12	5	50	150	0.10	0.125	10	20	80	250	8
2N3249	TO-18	360	15	12	5	100	300	0.10	0.125	10	90	100	300	8
2N3250	TO-18	360	50	40	5	50	150	10	0.25	10	70	225	250	6
2N3250A	TO-18	360	60	60	5	50	150	10	0.25	10	70	225	250	6
2N3251	TO-18	360	50	40	5	100	300	10	0.25	10	70	250	300	6
2N3251A	TO-18	360	60	60	5	100	300	10	0.25	10	70	250	300	6
2N3639	TO-106	200	6	6	4	30	120	10	0.25	10	25	25	500	6
2N3640	TO-106	200	12	12	4	30	120	10	0.3	10	25	35	500	3.5
2N3905	TO-92A	310	40	40	5	50	150	10	0.25	10	70	260	200	3.5
2N3906	TO-92A	310	40	40	5	100	300	10	0.25	10	70	300	250	4.5
2N4971	TO-106	200	50	40	5	40	120	150	0.15	150	—	150	200	8
2N4972	TO-106	200	50	40	5	100	300	150	0.4	150	—	—	200	8
2N5138	TO-106	200	30	30	5	50	800	0.1	0.25	10	50	200	300	5
2N5139	TO-106	200	20	20	5	40	—	10	0.5	50	50	200	300	5
2N5142	TO-105	300	20	20	4	15	—	300	2	300	—	200	100	10
2N5143	TO-106	200	20	20	4	15	—	300	2	300	—	200	100	10
BSX 29	TO-18	360	12	12	4	30	120	30	0.5	100	60	90	400	6
BSY 40	TO-18	300	25	20	5	20	60	10	0.2	10	25	100	140	—
BSY 41	TO-18	300	25	20	5	50	200	10	0.2	10	25	100	140	—

# Packaging Information

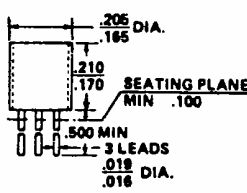
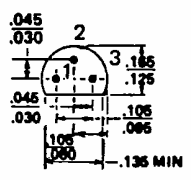
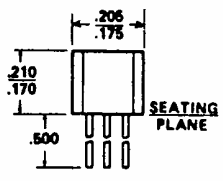
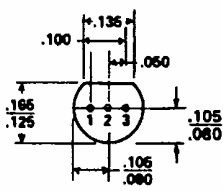
<p><b>PACKAGING INFORMATION</b></p>	<p>1. CATHODE 2. GATE 3. ANODE</p>  	<p><b>SCR</b> 1. CATHODE 2. GATE 3. ANODE</p>  
	<p><b>TO-18 (PLASTIC)</b></p>	<p><b>TO-92</b></p>

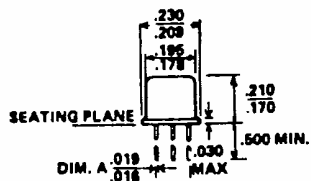
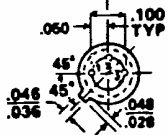
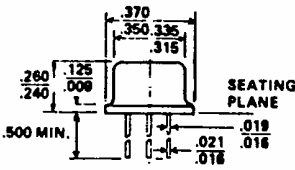
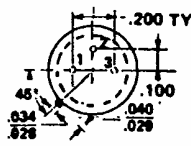
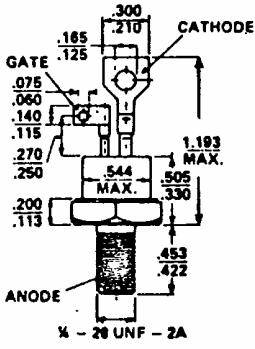
<p>1. CATHODE 2. GATE 3. ANODE</p>  	<p><b>SCR</b> 1. CATHODE 2. GATE 3. ANODE</p>  	<p><b>TRIAC</b> 1. MT 1 2. GATE 3. MT 2</p> 
<p><b>TO-18</b></p>	<p><b>TO-39</b></p>	<p><b>TO-48D</b></p>