

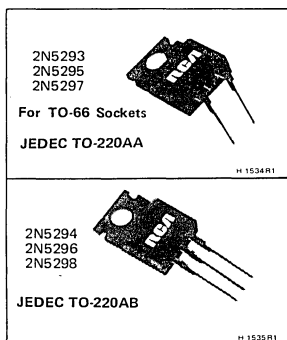

Power Transistors

2N5293 2N5294
 2N5295 2N5296
 2N5297 2N5298



Hometaxial-Base, Silicon N-P-N VERSAWATT Transistors

General-Purpose Types for Medium-Power Switching and Amplifier Applications in Military, Industrial, and Commercial Equipment

FEATURES

- Low saturation voltage—
 $V_{CE(sat)} = 1 \text{ V max. at } I_C = 0.5 \text{ A (2N5293, 2N5294)}$
 $= 1 \text{ V max. at } I_C = 1 \text{ A (2N5295, 2N5296)}$
 $= 1 \text{ V max. at } I_C = 1.5 \text{ A (2N5297, 2N5298)}$
- VERSAWATT package (molded-silicone plastic)
- Maximum safe-area-of-operation curves specified for DC and pulse service

RCA-2N5293, 2N5294, 2N5295, 2N5296, 2N5297 and 2N5298* are hometaxial-base silicon n-p-n transistors. They are intended for a wide variety of medium-power switching and amplifier applications such as series and shunt regulators, and in driver and output stages of high-fidelity amplifiers. Types 2N5293, 2N5295, and 2N5297 have formed emitter and base leads for easy insertion into TO-66 sockets. Types 2N5294, 2N5296, and 2N5298 are electrically identical to the 2N5293, 2N5295, and 2N5297, respectively, but have straight leads.

These new plastic power transistors differ in voltage ratings and in the currents at which the parameters are controlled.

* Formerly RCA Dev. Type Nos. TA7155, TA2911, TA7156, TA7137, TA7362, and TA7363, respectively.

MAXIMUM RATINGS, Absolute-Maximum Values:

	2N5293 2N5294	2N5295 2N5296	2N5297 2N5298	
COLLECTOR-TO-BASE VOLTAGE	80	60	80	V
COLLECTOR-TO-EMITTER SUSTAINING VOLTAGE:				
With -1.5 volts (V_{BE}) of reverse bias	80	60	80	V
With external base-to-emitter resistance (R_{BE}) = 100 Ω	75	50	70	V
With base open	70	40	60	V
EMITTER-TO-BASE VOLTAGE	7	5	5	V
COLLECTOR CURRENT	4	4	4	A
BASE CURRENT	2	2	2	A
TRANSISTOR DISSIPATION:				
At case temperatures up to 25°C	36	36	36	W
At case temperatures above 25°C		Derate linearly at 0.288 W/°C or see Fig. 1 & 2.		
At ambient temperatures up to 25°C	1.8	1.8	1.8	W
At ambient temperatures above 25°C		Derate linearly at 0.0144 W/°C		
TEMPERATURE RANGE:				
Storage & Operating (Junction)	-65 to +150			°C
LEAD TEMPERATURE (During Soldering):				
At distance \geq 1/8 in. (3.17 mm) from case for 10 s max.	235			°C

ELECTRICAL CHARACTERISTICS, At Case Temperature (T_C) = 25°C, Unless Otherwise Specified.

Characteristic	Symbol	TEST CONDITIONS				LIMITS						Units
		DC Voltage (V)		DC Current (A)		2N5293 2N5294		2N5295 2N5296		2N5297 2N5298		
		V_{CE}	V_{BE}	I_C	I_B	Min.	Max.	Min.	Max.	Min.	Max.	
Collector-Cutoff Current With base-emitter junction reverse biased	I_{CEV}	65 35	-1.5 -1.5			- -	0.5 -	- -	- 2	- -	0.5 -	mA
	I_{CEV} ($T_C = 150^\circ\text{C}$)	65 35	-1.5 -1.5			- -	3 -	- -	- 5	- -	3 -	mA
Collector-Cutoff Current With external base-to-emitter resistance (R_{BE}) = 100 Ω	I_{CER}	50				-	0.5	-	-	-	0.5	mA
	I_{CER} ($T_C = 150^\circ\text{C}$)	50				-	2	-	-	-	2	mA
Emitter-Cutoff Current	I_{EBO}		-7 -5			-	1	-	-	1	1	mA
DC Forward-Current Transfer Ratio	h_{FE}^c	4		0.5		30	120	-	-	-	-	
		4		1		-	-	30	120	-	-	
		4		1.5		-	-	-	-	20	80	
Collector-to-Emitter Sustaining Voltage With base open	$V_{CEO(sus)}^c$			0.1	0	70	-	-	-	-	-	V
				0.1	0	-	-	40	-	-	-	
				0.1	0	-	-	-	-	60	-	
With external base-to-emitter resistance (R_{BE}) = 100 Ω	$V_{CER(sus)}^c$			0.1		75	-	-	-	-	-	V
				0.1		-	-	50	-	-	-	
				0.1		-	-	-	-	70	-	
With base-emitter junction reverse biased	$V_{CEV(sus)}^c$		-1.5	0.1		80	-	-	-	-	-	V
			-1.5	0.1		-	-	60	-	-	-	
			-1.5	0.1		-	-	-	-	80	-	
Base-to-Emitter Voltage	V_{BE}^c	4		0.5		-	1.1	-	-	-	-	V
		4		1		-	-	-	1.3	-	-	
		4		1.5		-	-	-	-	-	1.5	
Collector-to-Emitter Saturation Voltage	$V_{CE(sat)}^c$			0.5	0.05	-	1	-	-	-	-	V
				1	0.1	-	-	-	1	-	-	
				1.5	0.15	-	-	-	-	-	1	
Gain-Bandwidth Product	f_T	4		0.2		0.8	-	0.8	-	0.8	-	MHz
Sat. Switching Time	Turn-On (See Figs. 22 - 24)	t_{on}	$V_{CC} = 30$	0.5	0.05 ^a	-	5	-	-	-	-	μs
				1	0.1 ^a	-	-	-	5	-	-	
				1.5	0.15 ^a	-	-	-	-	-	5	
Turn-Off (See Figs. 22 - 24)	t_{off}	$V_{CC} = 30$	0.5	-0.05 ^a	-	15	-	-	-	-	-	μs
			1	-0.1 ^b	-	-	-	15	-	-	-	
			1.5	-0.15 ^b	-	-	-	-	-	15	-	
Thermal Resistance; Junction-to-Case	θ_{J-C}					-	3.5	-	3.5	-	3.5	$^\circ\text{C/W}$
						-	70	-	70	-	70	$^\circ\text{C/W}$

^a I_{B1} value (turn-on base current).^b I_{B2} value (turn-off base current).^c Pulsed, pulse duration = 300 μs ,
duty factor = .018.

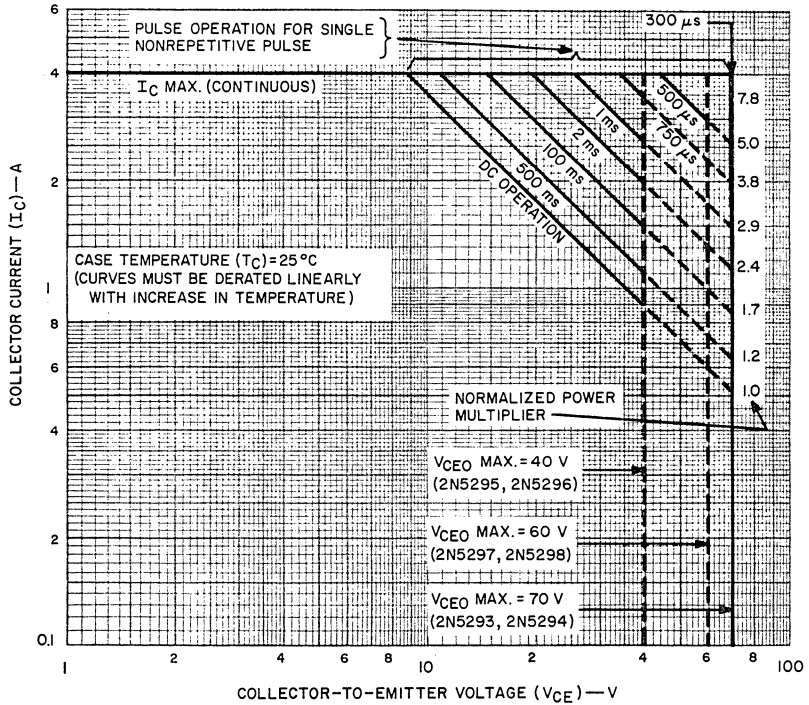

92CS-17160R1

Fig.1—Maximum operating areas for all types.

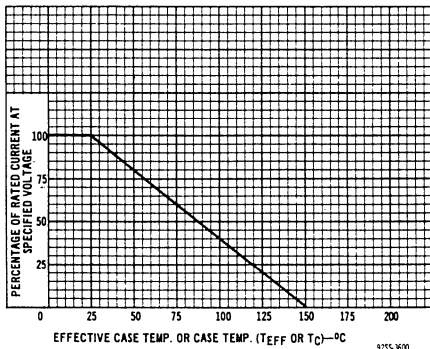

Fig.2—Derating curve for all types.

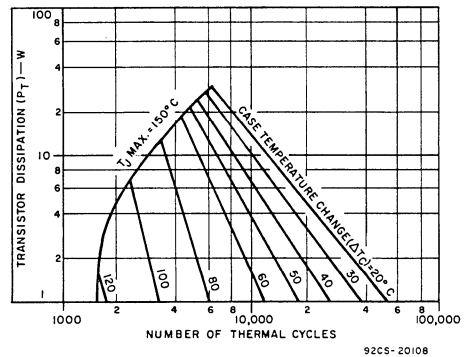

Fig.3—Thermal-cycling rating chart for all types.

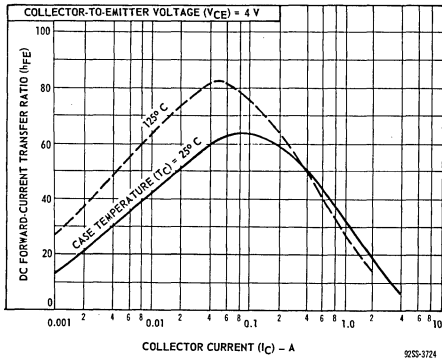

Fig.4 – Typical DC beta for types 2N5293 & 2N5294.

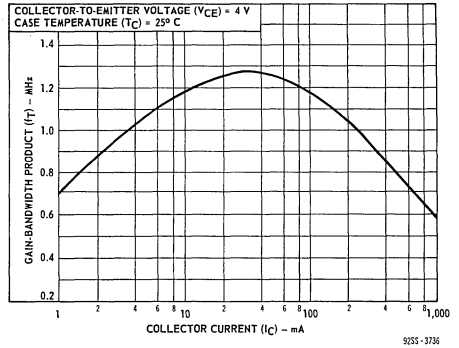

Fig.5 – Typical gain-bandwidth product for types 2N5293 & 2N5294.

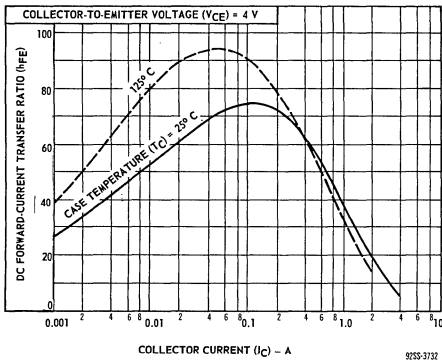

Fig.6 – Typical DC beta for types 2N5295 & 2N5296.

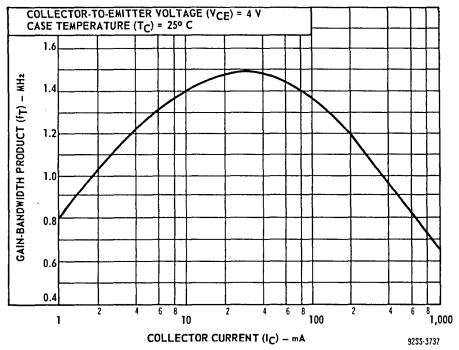

Fig.7 – Typical gain-bandwidth product for types 2N5295 & 2N5296.

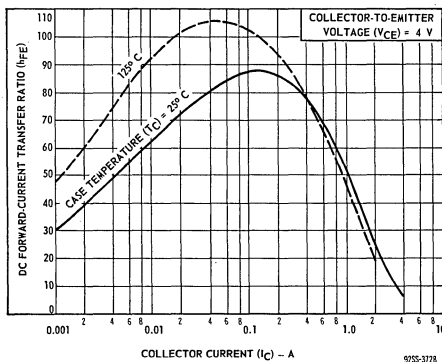

Fig.8 – Typical DC beta for types 2N5297 & 2N5298.

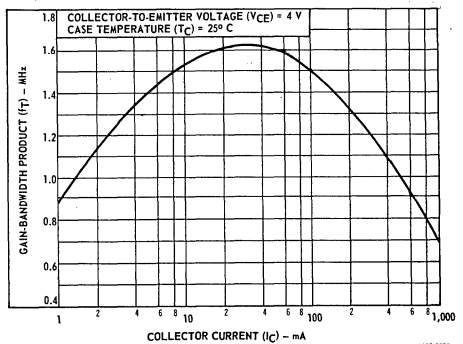

Fig.9 – Typical gain-bandwidth product for types 2N5297 & 2N5298.

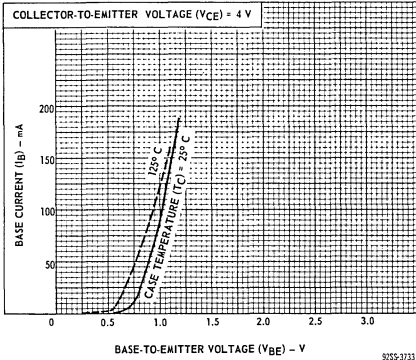

Fig. 10—Typical input characteristics for types 2N5293 & 2N5294.

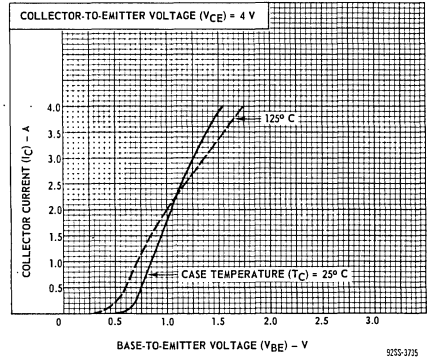

Fig. 11—Typical transfer characteristics for types 2N5293 & 2N5294.

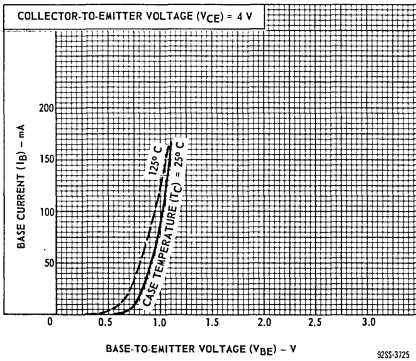

Fig. 12—Typical input characteristics for types 2N5295 & 2N5296.

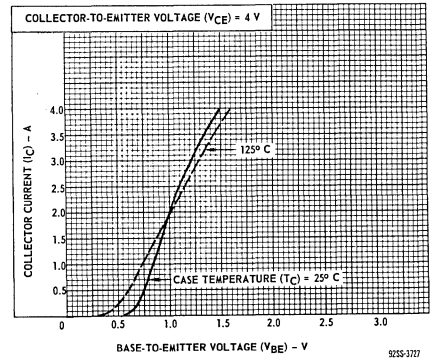

Fig. 13—Typical transfer characteristics for types 2N5295 & 2N5296.

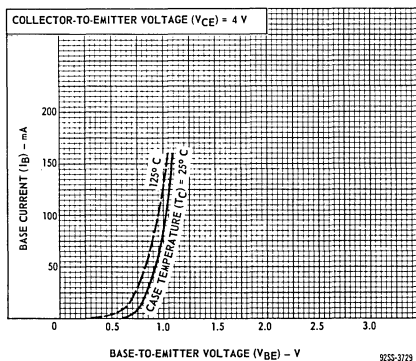

Fig. 14—Typical input characteristics for types 2N5297 & 2N5298.

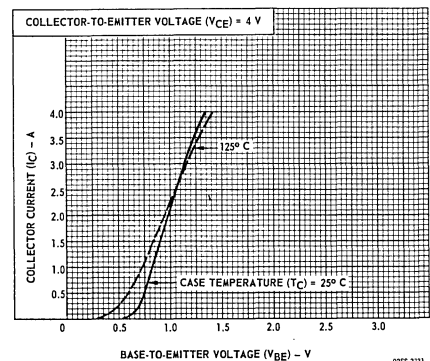

Fig. 15—Typical transfer characteristics for types 2N5297 & 2N5298.

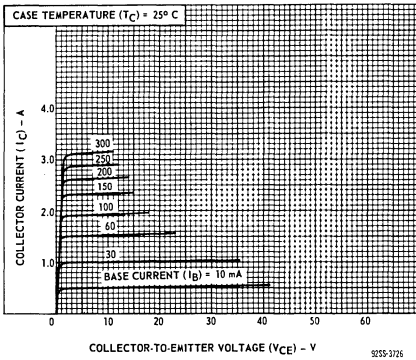

Fig.16—Typical output characteristics for types 2N5293 & 2N5294.

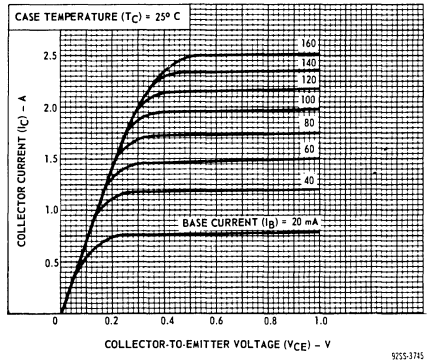

Fig.17—Typical output characteristics for types 2N5295 & 2N5296.

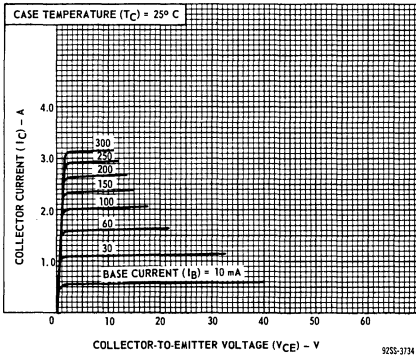

Fig.18—Typical output characteristics for types 2N5295 & 2N5296.

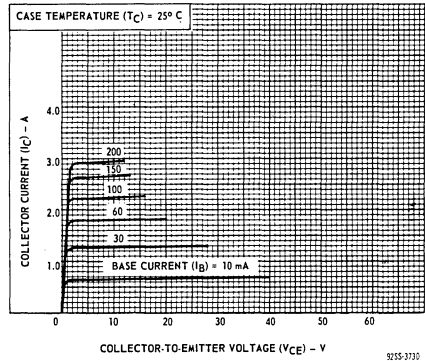

Fig.19—Typical output characteristics for types 2N5297 & 2N5298.

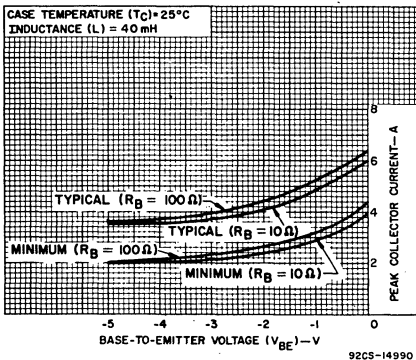

Fig.20—Reverse-bias, second-breakdown characteristics for all types.

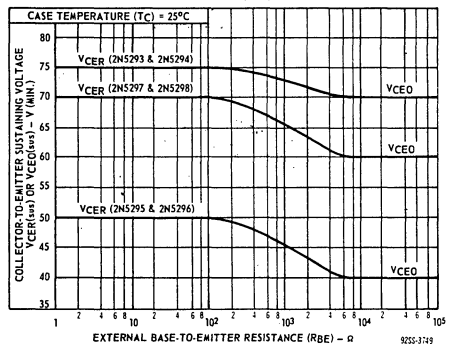

Fig.21—Sustaining voltage vs. base-to-emitter resistance for all types.

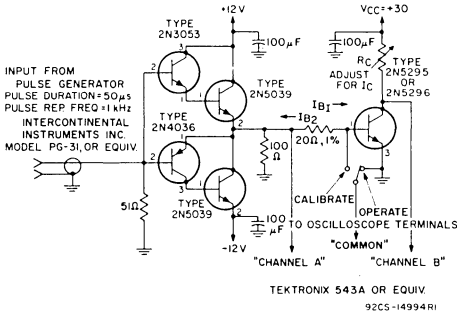

Fig.22—Circuit used to measure switching times for types 2N5295 & 2N5296.

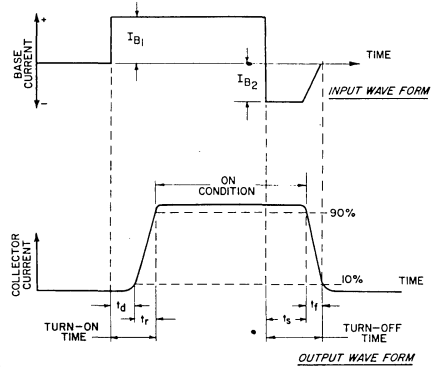

Fig.23—Phase relationship between input and output currents showing reference points for specification of switching times. (Test circuit shown in Fig.22.)

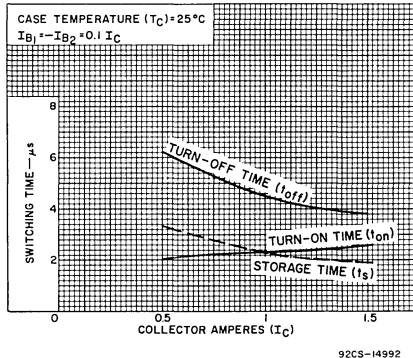

Fig.24—Typical saturated switching characteristics for types 2N5295 & 2N5296.

TERMINAL CONNECTIONS FOR TYPES 2N5293, 2N5295, AND 2N5297

- Lead No.1 - Base
- Lead No.3 - Emitter
- Mounting Flange - Collector
- - Do not use stub as tie point.

TERMINAL CONNECTIONS FOR TYPES 2N5294, 2N5296, AND 2N5298

- Lead No.1 - Base
- Lead No.2 - Collector
- Lead No.3 - Emitter
- Mounting Flange - Collector