

NPN 2N6057 – 2N6058 – 2N6059

POWER COMPLEMENTARY SILICON TRANSISTORS

The 2N6057, 2N6058 and 2N6059 are silicon epitaxial-base transistors in monolithic Darlington configuration mounted in Jedec TO-3 metal case.

They are intended for use in power linear and low frequency switching applications.

The complementary PNP types are 2N6050, 2N6051 and 2N6052 respectively.

Compliance to RoHS.

ABSOLUTE MAXIMUM RATINGS

Symbol	Ratings		Value	Unit	
V_{CBO}	Collector-Base Voltage	$I_E=0$	2N6050	60	V
			2N6051	80	
			2N6052	100	
V_{CEO}	Collector-Emitter Voltage	$I_B=0$	2N6050	60	V
			2N6051	80	
			2N6052	100	
V_{CEX}	Collector-Emitter Voltage	$V_{BE}=1.5\text{ V}$	2N6050	60	V
			2N6051	80	
			2N6052	100	
V_{EBO}	Emitter-Base Voltage	$I_C=0$	5.0	V	
I_C	Collector Current		12	A	
I_{CM}	Collector Peak Current		20	A	
I_B	Base Current		200	mA	
P_T	Power Dissipation	@ $T_C < 25^\circ$	150	W	
T_J	Junction Temperature		200	$^\circ\text{C}$	
T_s	Storage Temperature		-65 to +200		

THERMAL CHARACTERISTICS

Symbol	Ratings	Value	Unit
R_{thJ-C}	Thermal Resistance, Junction to Case	1.17	$^\circ\text{C/W}$

NPN 2N6057 – 2N6058 – 2N6059

ELECTRICAL CHARACTERISTICS

TC=25°C unless otherwise noted

Symbol	Ratings	Test Condition(s)	Min	Typ	MAx	Unit			
I_{CEX}	Collector Cutoff Current	$V_{CE} = V_{CEX} = 60\text{ V}, V_{BE} = -1.5\text{ V}$	2N6050	-	-	500	μA		
		$V_{CE} = V_{CEX} = 80\text{ V}, V_{BE} = -1.5\text{ V}$	2N6051	-	-				
		$V_{CE} = V_{CEX} = 100\text{ V}, V_{BE} = -1.5\text{ V}$	2N6052	-	-				
				$V_{CE} = V_{CEX} = 60\text{ V}, V_{BE} = -1.5\text{ V}, T_C = 150^\circ\text{C}$	2N6050	-	-	5	mA
				$V_{CE} = V_{CEX} = 80\text{ V}, V_{BE} = -1.5\text{ V}, T_C = 150^\circ\text{C}$	2N6051	-	-		
				$V_{CE} = V_{CEX} = 100\text{ V}, V_{BE} = -1.5\text{ V}, T_C = 150^\circ\text{C}$	2N6052	-	-		
I_{CEO}	Collector Cutoff Current	$V_{CE} = 30\text{ Vdc}, I_B = 0$	2N6050	-	-	1.0	mA		
		$V_{CE} = 40\text{ Vdc}, I_B = 0$	2N6051	-	-				
		$V_{CE} = 50\text{ Vdc}, I_B = 0$	2N6052	-	-				
I_{EBO}	Emitter Cutoff Current	$V_{EB} = 5\text{ V}$	2N6050	-	-	2.0	mA		
			2N6051	-	-				
			2N6052	-	-				
$V_{CEO(SUS)}$	Collector-Emitter Sustaining Voltage (*)	$I_C = 0.1\text{ A}$	2N6050	60	-	-	V		
			2N6051	80	-				
			2N6052	100	-				
$V_{CE(SAT)}$	Collector-Emitter saturation Voltage (*)	$I_C = 6\text{ A}, I_B = 24\text{ mA}$	2N6050	-	-	2.0	V		
			2N6051						
			2N6052						
		$I_C = 12\text{ A}, I_B = 120\text{ mA}$	2N6050	-	-	3.0			
			2N6051						
			2N6052						
$V_{BE(SAT)}$	Base-Emitter Saturation Voltage (*)	$I_C = 12\text{ A}, I_B = 120\text{ mA}$	2N6050	-	-	4	V		
			2N6051						
			2N6052						
$V_{BE(ON)}$	Base-Emitter Voltage (*)	$I_C = 6\text{ A}, V_{CE} = 3\text{ V}$	2N6050	-	-	2.8	V		
			2N6051						
			2N6052						
f_T	Transition Frequency	$I_C = 5\text{ A}, V_{CE} = 3\text{ V}, f = 1\text{ MHz}$	2N6050	4	-	-	MHz		
			2N6051						
			2N6052						
h_{FE}	DC Current Gain (*)	$V_{CE} = 3\text{ V}, I_C = 6.0\text{ A}$	2N6050	750	-	18000	-		
			2N6051						
			2N6052						
		$V_{CE} = 3.0\text{ V}, I_C = 12\text{ A}$	2N6050	100	-	-			
			2N6051						
			2N6052						

(*) Pulse Width $\approx 300\ \mu\text{s}$, Duty Cycle $\angle 2.0\%$

NPN 2N6057 – 2N6058 – 2N6059

MECHANICAL DATA CASE TO-3

DIMENSIONS (mm)		
	min	max
A	11	13.10
B	0.97	1.15
C	1.5	1.65
D	8.32	8.92
F	19	20
G	10.70	11.1
N	16.50	17.20
P	25	26
R	4	4.09
U	38.50	39.30
V	30	30.30

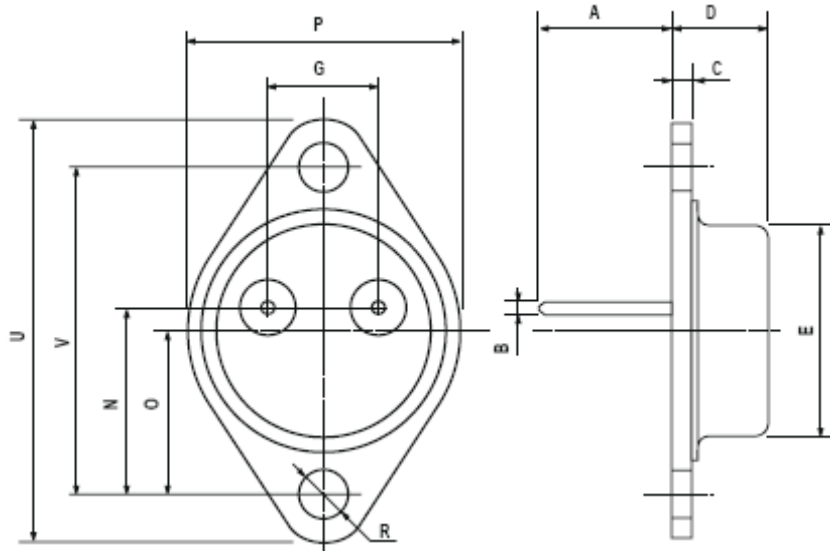

Pin 1 :	Base
Pin 2 :	Emitter
Case :	Collector

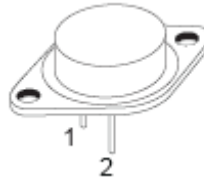

Revised September 2012

Information furnished is believed to be accurate and reliable. However, Comset Semiconductors assumes no responsibility for the consequences of use of such information nor for any infringement of patents or other rights of third parties which may result from its use. Data are subject to change without notice. Comset Semiconductors makes no warranty, representation or guarantee regarding the suitability of its products for any particular purpose, nor does Comset Semiconductors assume any liability arising out of the application or use of any product and specifically disclaims any and all liability, including without limitation consequential or incidental damages. Comset Semiconductors' products are not authorized for use as critical components in life support devices or systems.