



NPN POWER TRANSISTORS

2N6292

**70 VOLTS
7 AMP, 40 WATTS**

These general-purpose medium-power transistors are intended for a wide variety of medium-power switching and amplifier applications, such as series and shunt regulators and driver and output stages of high-fidelity amplifiers.

Features:

- Low saturation voltages
- Thermal-cycling ratings
- Maximum safe-area-of-operation curves specified for dc operation.

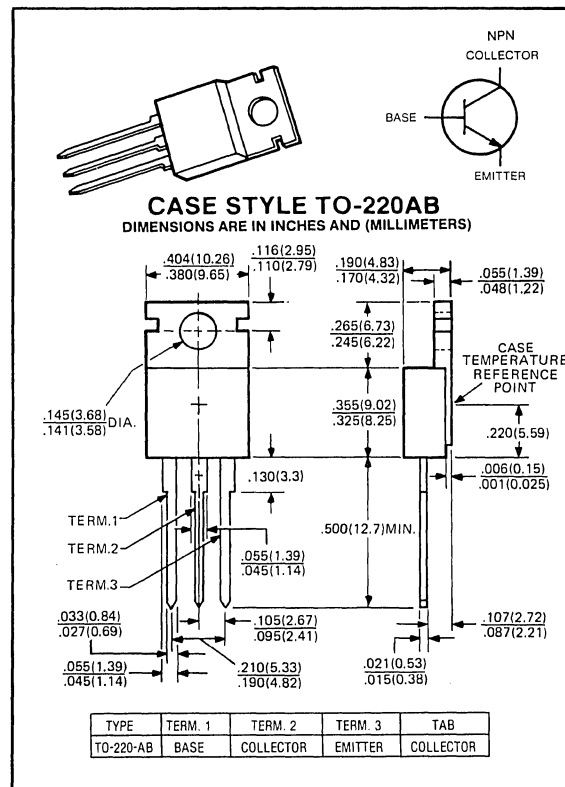

maximum ratings ($T_A = 25^\circ C$) (unless otherwise specified)

RATING	SYMBOL	2N6292	UNITS
Collector-Emitter Voltage	V_{CEO}	70	Volts
Collector-Base Voltage	V_{CBO}	80	Volts
Emitter Base Voltage	V_{EBO}	5	Volts
Collector Current — Continuous Peak	I_C I_{CM}	7	A
Base Current — Continuous	I_B	3	A
Total Power Dissipation @ $T_A = 25^\circ C$ @ $T_C = 25^\circ C$	P_D	1.8 40	Watts W/ $^\circ C$
Operating and Storage Junction Temperature Range	T_J, T_{STG}	-65 to +150	$^\circ C$

thermal characteristics

Thermal Resistance, Junction to Ambient	$R_{\theta JA}$	70	$^\circ C/W$
Thermal Resistance, Junction to Case	$R_{\theta JC}$	3.125	$^\circ C/W$
Maximum Lead Temperature for Soldering Purposes: 1/8" from Case for 5 Seconds	T_L	235	$^\circ C$

electrical characteristics ($T_C = 25^\circ\text{C}$) (unless otherwise specified)

CHARACTERISTIC	SYMBOL	MIN	TYP	MAX	UNIT
----------------	--------	-----	-----	-----	------

off characteristics

Collector-Emitter Sustaining Voltage ($I_C = .1\text{mA}$)	$V_{CE(sus)}$	70	—	—	Volts
Collector-Emitter Sustaining Voltage ($I_C = .1\text{mA}$, $I_B = 1.5\text{V}$)	$V_{CER(sus)}$	80	—	—	Volts
Collector Cutoff Current ($V_{CE} = 60\text{V}$)	I_{CEO}	—	—	1	mA
Collector Cutoff Current ($V_{CE} = 75\text{V}$, $V_{EB} = 1.5\text{V}$)	I_{CEX}	—	—	0.1	mA
Emitter Cutoff Current ($V_{EB} = 5\text{V}$)	I_{EBO}	—	—	1	mA

second breakdown

Second Breakdown with Base Forward Biased	FBSOA	SEE FIGURE 2
---	-------	--------------

on characteristics

DC Current Gain ($I_C = 2\text{A}$, $V_{CE} = 4\text{V}$) ($I_C = 7\text{A}$, $V_{CE} = 4\text{V}$)	h_{FE}	30 2.3	— —	150 —	—
Collector-Emitter Saturation Voltage ($I_C = 2.5\text{A}$, $I_B = .25\text{A}$) ($I_C = 7\text{A}$, $I_B = 3\text{A}$)	$V_{CE(sat)}$	— —	— —	1 3.5	V V
Base-Emitter Voltage ($I_C = 2\text{A}$, $V_{CE} = 4\text{V}$) ($I_C = 7\text{A}$, $V_{CE} = 4\text{V}$)	$V_{BE(on)}$	— —	— —	1.5 3	V

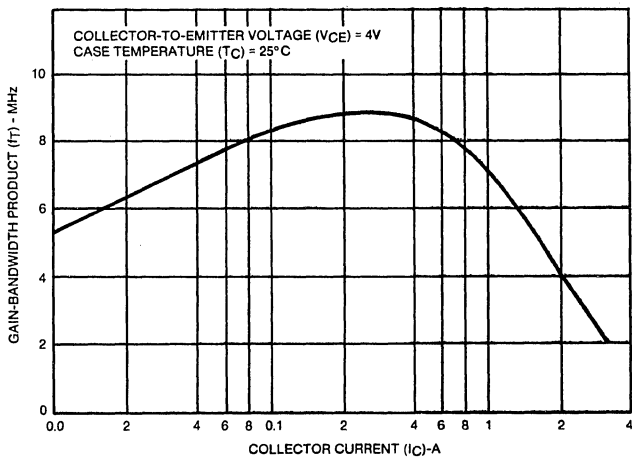

FIG. 1 TYPICAL GAIN-BANDWIDTH

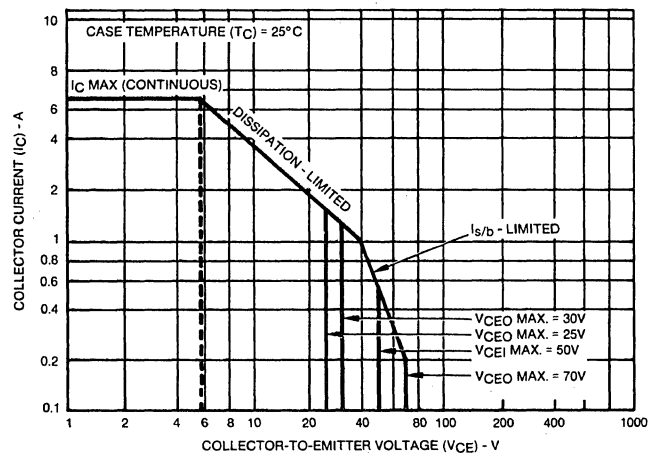

FIG. 2 MAXIMUM OPERATING AREA

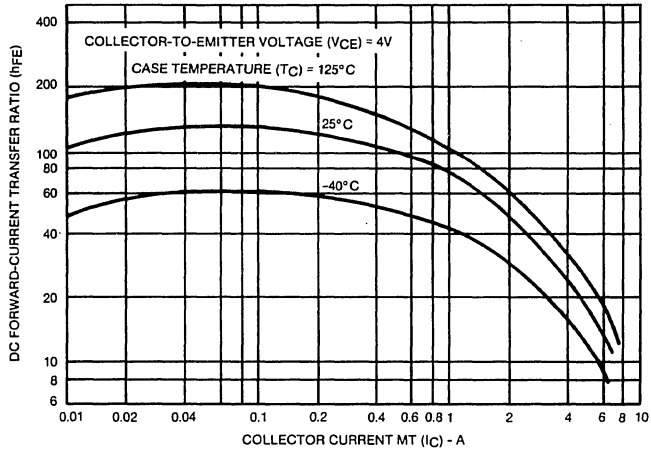

FIG. 3 TYPICAL CHARACTERISTICS

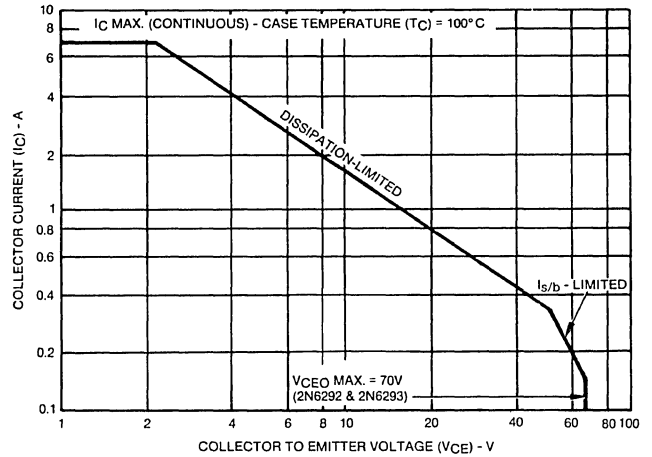

FIG. 4 MAXIMUM OPERATING AREA

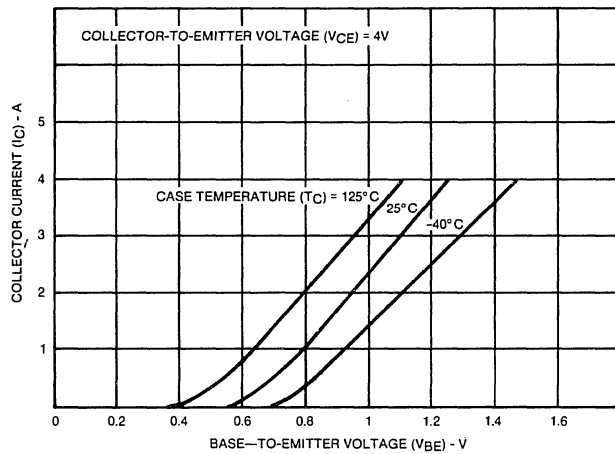

FIG. 5 TYPICAL TRANSFER CHARACTERISTICS

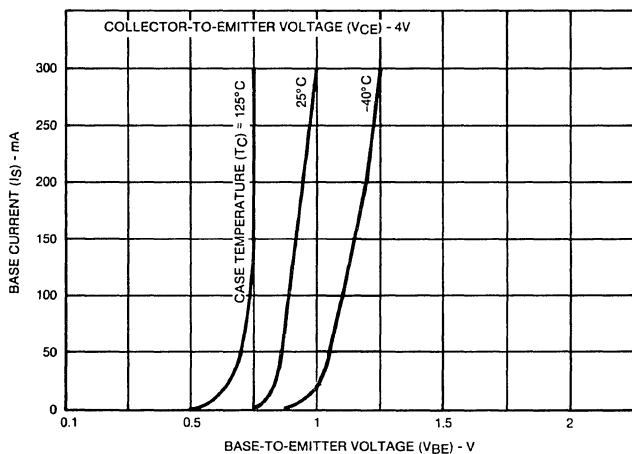

FIG. 6 TYPICAL INPUT CHARACTERISTICS

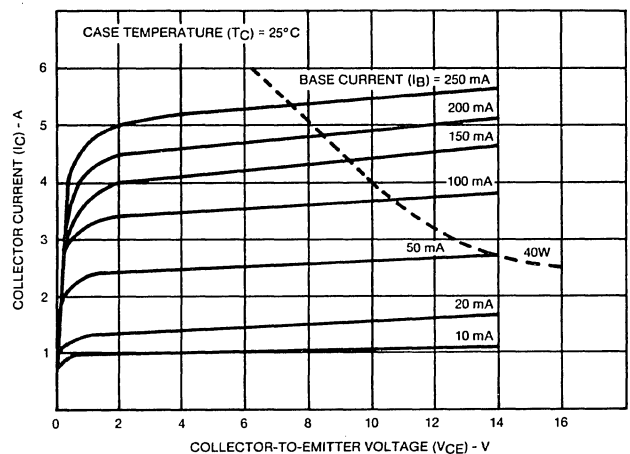

FIG. 7 TYPICAL OUTPUT CHARACTERISTICS