

NPN POWER SILICON TRANSISTOR

Qualified per MIL-PRF-19500/525

Devices

2N6546

2N6547

Qualified Level

JAN
JANTX
JANTXV

MAXIMUM RATINGS

Ratings	Symbol	2N6546	2N6547	Units
Collector-Emitter Voltage	V_{CEO}	300	400	Vdc
Collector-Base Voltage	V_{CEX}	600	850	Vdc
Emitter-Base Voltage	V_{EBO}	8		Vdc
Base Current	I_B	10		Adc
Collector Current	I_C	15		Adc
Total Power Dissipation	P_T	@ $T_C = +25^{\circ}\text{C}$ ⁽¹⁾	175	W
		@ $T_C = +100^{\circ}\text{C}$ ⁽¹⁾	100	W
Operating & Storage Temperature Range	T_{op}, T_{stg}	-65 to +200		$^{\circ}\text{C}$

THERMAL CHARACTERISTICS

Characteristics	Symbol	Max.	Unit
Thermal Resistance, Junction-to-Case	$R_{\theta JC}$	1.0	$^{\circ}\text{C}/\text{W}$

1) Between $T_C = +25^{\circ}\text{C}$ and $T_C = +200^{\circ}\text{C}$, linear derating factor (average) = 1.0 W/ $^{\circ}\text{C}$

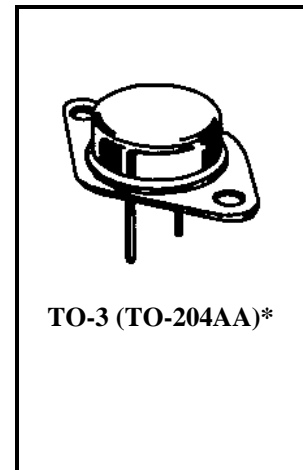

*See Appendix A for Package Outline

ELECTRICAL CHARACTERISTICS

Characteristics	Symbol	Min.	Max.	Unit
-----------------	--------	------	------	------

OFF CHARACTERISTICS

Collector-Emitter Breakdown Voltage $I_C = 100 \text{ mAdc}$	2N6546 2N6547	$V_{(BR)CEO}$	300 400	Vdc
Collector-Emitter Cutoff Current $V_{CE} = 600 \text{ Vdc}; V_{BE} = 1.5 \text{ Vdc}$ $V_{CE} = 850 \text{ Vdc}; V_{BE} = 1.5 \text{ Vdc}$	2N6546 2N6547	I_{CEX}	1.0 1.0	mAdc
Emitter-Base Cutoff Current $V_{EB} = 8 \text{ Vdc}$		I_{EBO}	1.0	mAdc

6 Lake Street, Lawrence, MA 01841

1-800-446-1158 / (978) 794-1666 / Fax: (978) 689-0803

120101

Page 1 of 2

2N6546, 2N6547 JAN SERIES

ELECTRICAL CHARACTERISTICS (con't)

Characteristics	Symbol	Min.	Max.	Unit
ON CHARACTERISTICS⁽³⁾				
Forward-Current Transfer Ratio I _C = 1 Adc; V _{CE} = 2 Vdc I _C = 5 Adc; V _{CE} = 2 Vdc I _C = 10 Adc; V _{CE} = 2 Vdc	h _{FE}	15 12 6	60	
Base-Emitter Saturated Voltage I _B = 2.0 Adc; I _C = 10 Adc	V _{BE(sat)}		1.6	Vdc
Collector-Emitter Saturated Voltage I _B = 2.0 Adc; I _C = 10 Adc I _B = 3.0 Adc; I _C = 15 Adc	V _{CE(sat)}		1.5 5.0	Vdc

DYNAMIC CHARACTERISTICS

Magnitude of Common-Emitter Small-Signal Short-Circuit Forward Current Transfer Ratio I _C = 0.5 Adc, V _{CE} = 10 Vdc, f = 1 MHz	h _{fe}	6.0	30	
Output Capacitance V _{CB} = 10 Vdc, I _E = 0, 0.1 MHz ≤ f ≤ 1.0 MHz	C _{obo}		500	pF

SWITCHING CHARACTERISTICS

Turn-On Time V _{CC} = 250 Vdc; I _C = 10 Adc; I _{B1} = I _{B2} = 2 Adc	t _{on}		1.0	μs
Turn-Off Time V _{CC} = 250 Vdc; I _C = 10 Adc; I _{B1} = I _{B2} = 2 Adc	t _{off}		4.7	μs

SAFE OPERATING AREA

DC Tests	
T _C = +25°C; t _p = 1 s; 1 cycle (See Figure 3 of MIL-PRF-19500/525)	
Test 1	
V _{CE} = 11.7 Vdc; I _C = 15 Adc	
Test 2	
V _{CE} = 20 Vdc; I _C = 8.75 Adc	
Test 3	
V _{CE} = 250 Vdc; I _C = 45 mAdc	2N6546
V _{CE} = 350 Vdc; I _C = 30 mAdc	2N6547
Unclamped Inductive IOAD	
T _C = +25°C; duty cycle ≤ 10%; R _S = 0.1 Ω; t _r = t _f ≤ 500 ns (See Figure 4 of MIL-PRF-19500/525)	
Test 1	
T _p = 5 ms; (vary to obtain I _C); R _{BB1} = 15 Ω; V _{BB1} = 38.5 Vdc; R _{BB2} = 50 Ω; V _{BB2} = -4 Vdc; V _{CC} = 20 Vdc; I _C = 15 Adc; L = 10 μH	
Test 2	
T _p = 5 ms; (vary to obtain I _C); R _{BB1} = 15 Ω; V _{BB1} = 38.5 Vdc; R _{BB2} = 50 Ω; V _{BB2} = -4 Vdc; V _{CC} = 20 Vdc; I _C = 100 mAdc; L = 1 mH	
Clamped Inductive Load	
T _A = +25°C; duty cycle ≤ 5%; T _p = 1.5 ms; (vary to obtain I _C); V _{CC} = 20 Vdc; I _C = 8 Adc; L = 180 μH (See Figure 5 of MIL-PRF-19500/525)	
Clamped Voltage = 350 Vdc	2N6546
Clamped Voltage = 450 Vdc	2N6547

3.) Pulse Test: Pulse Width = 300μs, Duty Cycle ≤ 2.0%.