

2N6548
2N6549

NPN SILICON
DARLINGTON TRANSISTOR



TO-202 CASE



www.centrasemi.com

DESCRIPTION:

The CENTRAL SEMICONDUCTOR 2N6548 series types are NPN silicon Darlington transistors designed for amplifier and driver applications where high gain at a high collector current is important.

MARKING: FULL PART NUMBER

MAXIMUM RATINGS: ($T_A=25^\circ\text{C}$)

Collector-Base Voltage
Collector-Emitter Voltage
Collector-Emitter Voltage
Emitter-Base Voltage
Continuous Collector Current
Continuous Base Current
Power Dissipation
Power Dissipation ($T_C=25^\circ\text{C}$)
Operating and Storage Junction Temperature
Thermal Resistance
Thermal Resistance

SYMBOL		UNITS
V_{CBO}	50	V
V_{CES}	40	V
V_{CEO}	40	V
V_{EBO}	12	V
I_C	2.0	A
I_B	0.1	A
P_D	2.0	W
P_D	10	W
T_J, T_{stg}	-65 to +150	$^\circ\text{C}$
θ_{JA}	62.5	$^\circ\text{C/W}$
θ_{JC}	12.5	$^\circ\text{C/W}$

ELECTRICAL CHARACTERISTICS: ($T_A=25^\circ\text{C}$)

SYMBOL	TEST CONDITIONS	2N6548		2N6549		UNITS
		MIN	MAX	MIN	MAX	
I_{CBO}	$V_{CB}=30\text{V}$	-	100	-	100	nA
I_{EBO}	$V_{EB}=10\text{V}$	-	100	-	100	nA
BV_{CBO}	$I_C=100\mu\text{A}$	50	-	50	-	V
BV_{CES}	$I_C=100\mu\text{A}$	40	-	40	-	V
BV_{EBO}	$I_E=10\mu\text{A}$	12	-	12	-	V
$V_{CE(SAT)}$	$I_C=1.0\text{A}, I_B=2.0\text{mA}$	-	1.5	-	1.5	V
$V_{CE(SAT)}$	$I_C=2.0\text{A}, I_B=4.0\text{mA}$	-	2.0	-	2.0	V
$V_{BE(SAT)}$	$I_C=1.0\text{A}, I_B=2.0\text{mA}$	-	2.0	-	2.0	V
$V_{BE(ON)}$	$V_{CE}=5.0\text{V}, I_C=1.0\text{A}$	-	2.0	-	2.0	V
h_{FE}	$V_{CE}=5.0\text{V}, I_C=200\text{mA}$	25K	150K	15K	150K	
h_{FE}	$V_{CE}=5.0\text{V}, I_C=500\text{mA}$	15K	-	10K	-	
h_{FE}	$V_{CE}=5.0\text{V}, I_C=1.0\text{A}$	5K	-	3K	-	
h_{fe}	$V_{CE}=5.0\text{V}, I_C=50\text{mA}, f=1.0\text{kHz}$	20K	-	15K	-	
f_T	$V_{CE}=5.0\text{V}, I_C=200\text{mA}, f=100\text{MHz}$	100	-	100	-	MHz
C_{ob}	$V_{CB}=10\text{V}, I_E=0, f=1.0\text{MHz}$	-	7.0	-	7.0	pF

R1 (23-January 2012)

2N6548
2N6549

NPN SILICON
DARLINGTON TRANSISTOR



TO-202 CASE - MECHANICAL OUTLINE

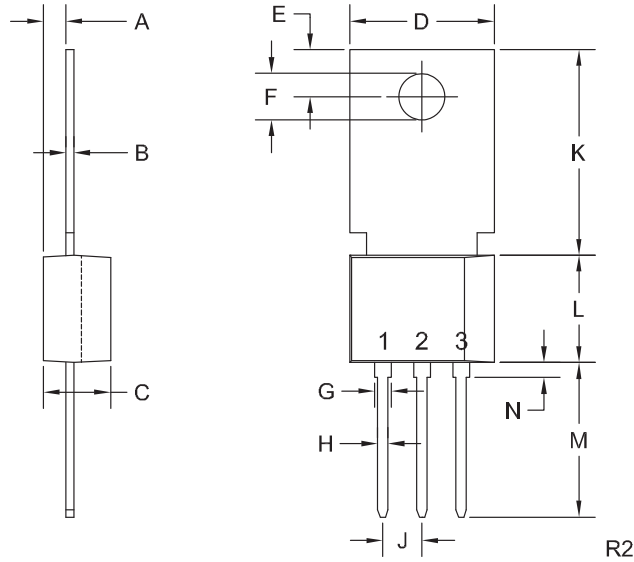

LEAD CODE:
1) Emitter
2) Base
3) Collector
Tab is common to pin 3

MARKING:
FULL PART NUMBER

SYMBOL	INCHES		MILLIMETERS	
	MIN	MAX	MIN	MAX
A	0.055	0.071	1.40	1.80
B	0.016	0.024	0.40	0.60
C	0.173	0.181	4.40	4.60
D	0.374	0.413	9.50	10.5
E	0.118	0.154	3.00	3.90
F (DIA)	0.124	0.150	3.15	3.80
G	0.035	0.055	0.90	1.40
H	0.023	0.031	0.59	0.80
J	0.094	0.106	2.39	2.69
K	0.459	0.559	11.66	14.21
L	0.280	0.346	7.12	8.80
M	0.406	0.531	10.3	13.5
N	0.024	0.059	0.60	1.50

TO-202 (REV: R2)

R1 (23-January 2012)