



HIGH VOLTAGE/HIGH SPEED NPN POWER TRANSISTORS

GE EQUIVALENT D64VS3, 4, 5

2N6676,77,78

**300-400 VOLTS
15 AMP, 175 WATTS**

The 2N6676, 2N6677 and 2N6678 series of NPN power transistors is designed for use in power switching applications requiring high-voltage capability, fast switching speeds and low-saturation voltages. These devices are optimized to provide a unique combination of ultra-low switching losses and high safe-operating area (SOA), ideally suited for off-line Switching Power Supplies, converter circuits and pulse width modulated regulators.

Features:

- 100°C maximum limits specified for:
 - Switching times
 - Saturation voltages
 - Leakage currents
- RBSOA ($V_{CEX} = 350$ to $450V$) at rated I_C continuous.
- Very fast turn-off: $t_f < 100$ nsec (typ.)
@ 15A — Inductive Load

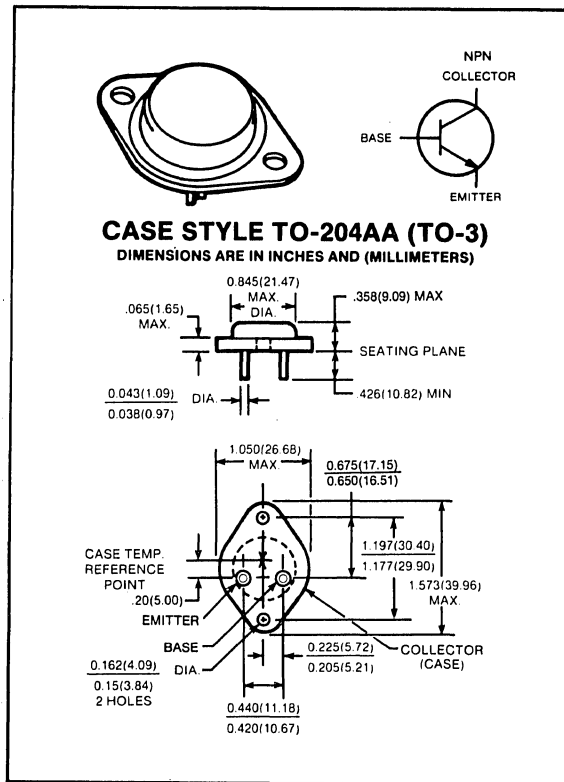

maximum ratings

RATING	SYMBOL	2N6676	2N6677	2N6678	UNITS
Collector-Emitter Voltage	V_{CEO}	300	350	400	Volts
Collector-Emitter Voltage	V_{CEX}	350	400	450	Volts
Collector-Emitter Voltage	V_{CEV}	450	550	650	Volts
Emitter Base Voltage	V_{EBO}	8	8	8	Volts
Collector Current — Continuous	I_C	15	15	15	A
Peak ⁽¹⁾	I_{CM}	20	20	20	
Base Current — Continuous	I_B	5	5	5	A
Peak ⁽¹⁾	I_{BM}	10	10	10	
Emitter Current — Continuous	I_E	20	20	20	A
Peak ⁽¹⁾	I_{EM}	30	30	30	
Total Power Dissipation @ $T_c = 25^\circ C$	P_D	178	178	178	Watts
Derate above $25^\circ C$		1.0	1.0	1.0	W/ $^\circ C$
Operating and Storage Junction Temperature Range	T_J, T_{STG}	-65 to +200	-65 to +200	-65 to +200	$^\circ C$

thermal characteristics

Thermal Resistance, Junction to Case	$R_{\theta JC}$	1.0	1.0	1.0	$^\circ C/W$
Maximum Lead Temperature for Soldering Purpose: 1/8" from Case for 5 Seconds	T_L	235	235	235	$^\circ C$

(1) Pulse Test: Pulse Width = 5ms. Duty Cycle $\leq 10\%$.

electrical characteristics ($T_C = 25^\circ\text{C}$) (unless otherwise specified)

CHARACTERISTIC	SYMBOL	MIN	MAX	UNIT
----------------	--------	-----	-----	------

off characteristics

Collector-Emitter Sustaining Voltage ⁽¹⁾ ($I_C = 100\text{mA}$, $I_B = 0$)	2N6676 2N6677 2N6678	$V_{CEO(sus)}$	300 350 400	— — —	Volts
Collector-Emitter Voltage ($I_C = 15\text{A}$, $I_{B1} = 3\text{A}$, $I_{B2} = 3.0\text{A}$) ($V_{BE(OFF)} = -6\text{V}$, $L = 50\ \mu\text{h}$)	2N6676 2N6677 2N6678	V_{CEX}	350 400 450	— — —	Volts
Collector Cutoff Current ($V_{CEV} = \text{Rated Value}$, $V_{BE(off)} = -1.5\text{V}$) ($V_{CEV} = \text{Rated Value}$, $V_{BE(off)} = -1.5\text{V}$, $T_C = 100^\circ\text{C}$)		I_{CEV}	— —	0.1 1.0	mA
Emitter Cutoff Current ($V_{EB} = 8\text{V}$, $I_C = 0$)		I_{EBO}	—	2.0	mA

second breakdown

Second Breakdown with Base Forward Biased	FBSOA	SEE FIGURE 13
Clamped Inductive SOA with Base Reversed Bias	RBSOA	SEE FIGURE 14

on characteristics

DC Current Gain ($I_C = 10\text{A}$, $V_{CE} = 2\text{V}$) ($I_C = 15\text{A}$, $V_{CE} = 3\text{V}$)	h_{FE}	10 8	— —	—
Collector-Emitter Saturation Voltage ($I_C = 10\text{A}$, $I_B = 2.0\text{A}$) ($I_C = 15\text{A}$, $I_B = 3.0\text{A}$) ($I_C = 15\text{A}$, $I_B = 3.0\text{A}$, $T_C = 100^\circ\text{C}$)	$V_{CE(SAT)}$	— — —	0.7 1.5 2.0	Volts
Base-Emitter Saturation Voltage ($I_C = 15\text{A}$, $I_B = 3.0\text{A}$) ($I_C = 15\text{A}$, $I_B = 3.0\text{A}$, $T_C = 100^\circ\text{C}$)	$V_{BE(SAT)}$	— —	1.5 1.5	Volts

dynamic characteristics

Current Gain — Bandwidth Product ($I_C = 1.0\text{A}$, $V_{CE} = 10\text{V}$, $f_{test} = 1.0\text{ MHz}$)	f_T	15	50	MHz
Small Signal Current Gain ($I_C = 2.0\text{A}$, $V_{CE} = 10\text{V}$, $f_{test} = 5\text{ MHz}$)	h_{FE}	3	10	—
Output Capacitance ($V_{CB} = 10\text{V}$, $I_E = 0$, $f = 0.1\text{ MHz}$)	C_{OB}	150	500	pF

switching characteristics

		MAXIMUM			
Resistive Load (See Figure 17 for Test Circuit)		T_C	25°C	100°C	
Delay Time	$V_{CC} = 200\text{V}$, $I_C = 15\text{A}$	t_d	0.1	0.2	μs
Rise Time	$I_{B1} = I_{B2} = 3\text{A}$, $V_{BE} = -6\text{V}$	t_r	0.6	1.0	μsec
Storage Time	$t_p = 20\ \mu\text{sec}$	t_s	2.5	4.0	μsec
Fall Time		t_f	0.5	1.0	μsec
Inductive Load, Clamped (See Figure 17 for Test Circuit)					
Storage Time	$V_{CC} = 200\text{V}$, $I_C = 15\text{A}$	t_s	3.0	4.5	μs
Fall Time	$V_{CLAMP} = \text{Rated } V_{CEX}$	t_f	0.3	0.6	μsec
Switch Time	$I_{B2} = 3.0\text{A}$, $V_{BE(OFF)} = -6\text{V}$ $L = 50\ \mu\text{h}$, $R_C \leq 13.5\ \Omega$, $t_p = 20\ \mu\text{sec}$	t_c	0.5	0.8	μsec

(1) Pulse Duration = $300\ \mu\text{s}$, Duty Factor $\leq 2\%$. Do not measure on a curve tracer.

* In accordance with JEDEC Registered Data.

TYPICAL DC CHARACTERISTICS

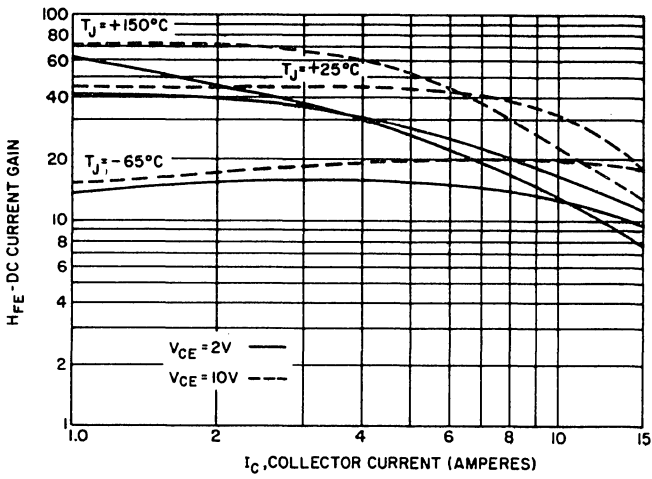

FIGURE 1. DC CURRENT GAIN

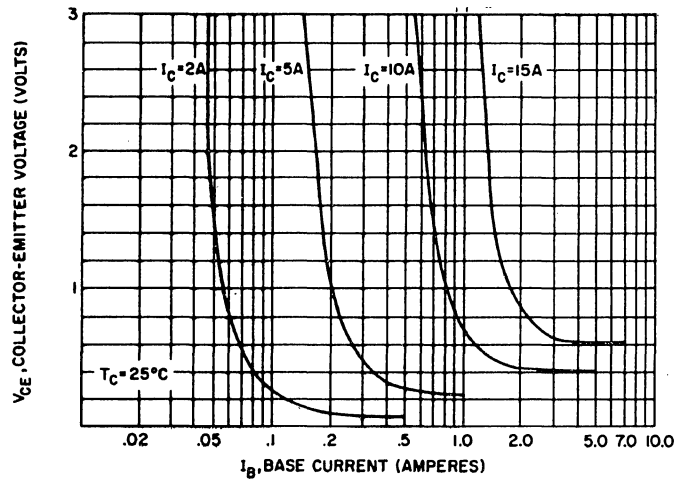

FIGURE 2. COLLECTOR SATURATION REGION

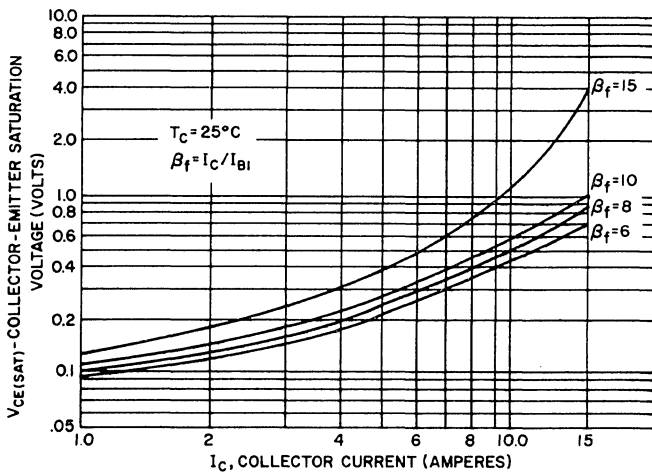

FIGURE 3. $V_{CE(sat)}$ vs I_C , $T_C = 25^\circ\text{C}$

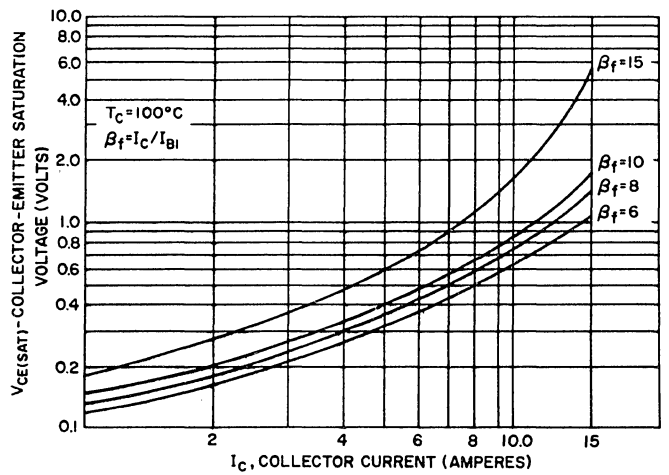

FIGURE 4. $V_{CE(sat)}$ vs I_C , $T_C = 100^\circ\text{C}$

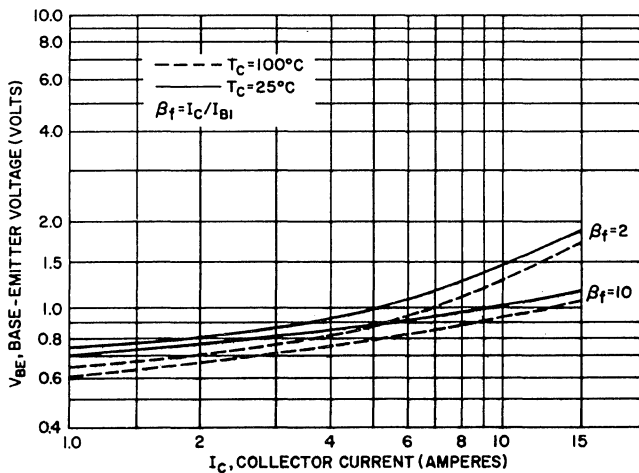

FIGURE 5. $V_{BE(sat)}$ vs I_C

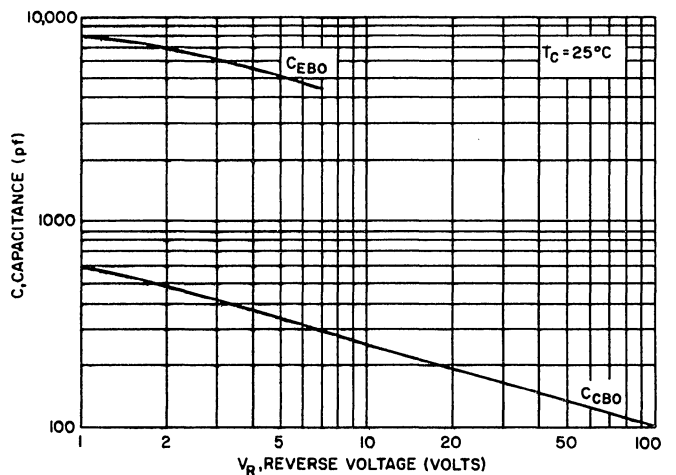

FIGURE 6. CAPACITANCE

TYPICAL SWITCHING CHARACTERISTICS

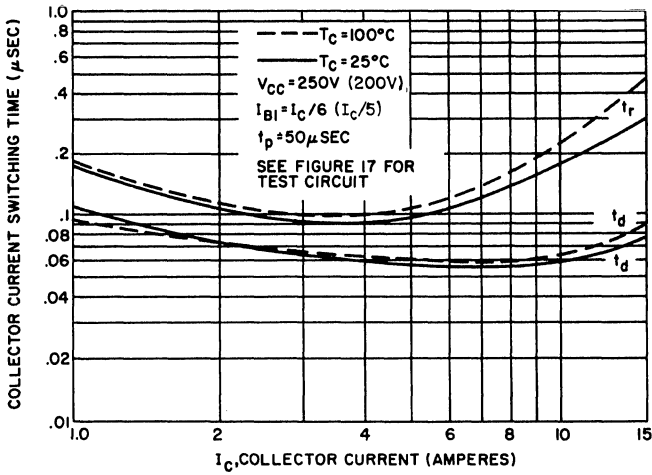

FIGURE 7. TURN-ON TIME RESISTIVE LOAD

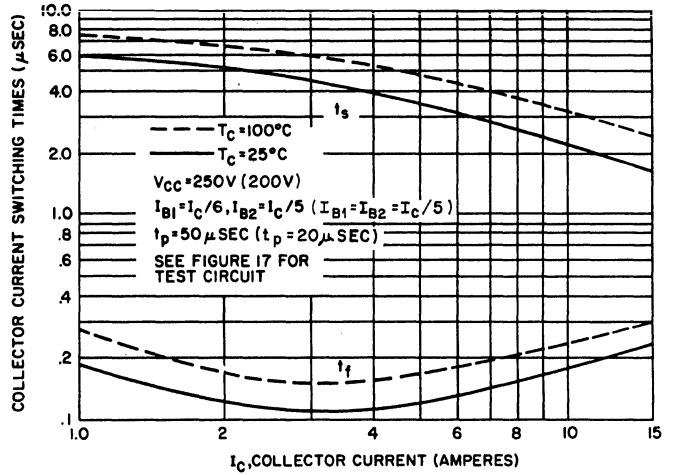

FIGURE 8. TURN-OFF TIME RESISTIVE LOAD

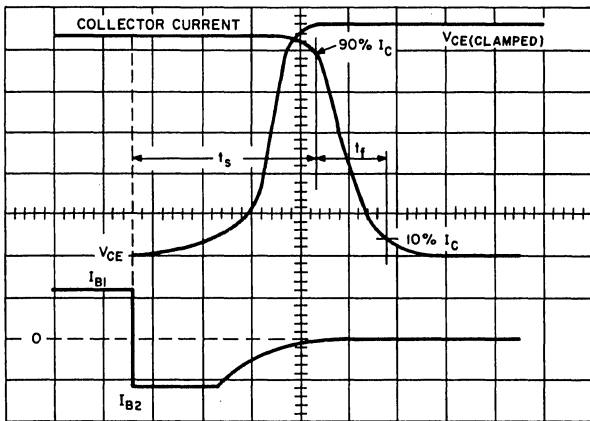

FIGURE 9. INDUCTIVE TURN-OFF WAVEFORMS

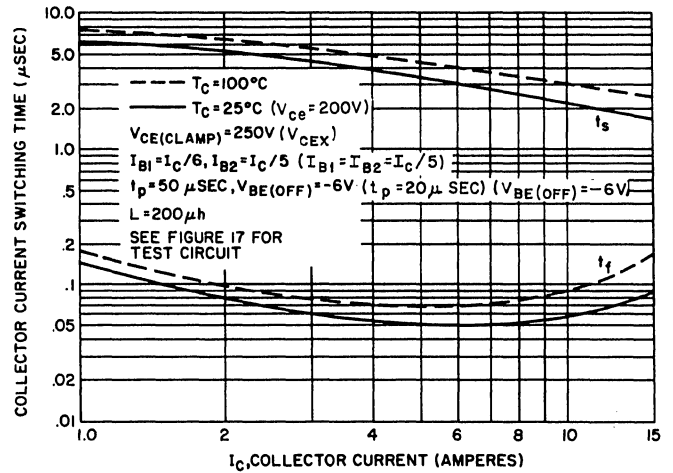

FIGURE 10. CLAMPED INDUCTIVE TURN-OFF TIME

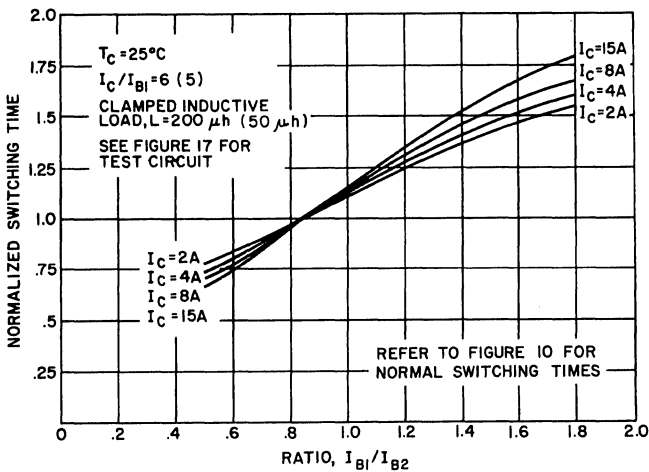

FIGURE 11. STORAGE TIME VARIATION WITH I_{B2}

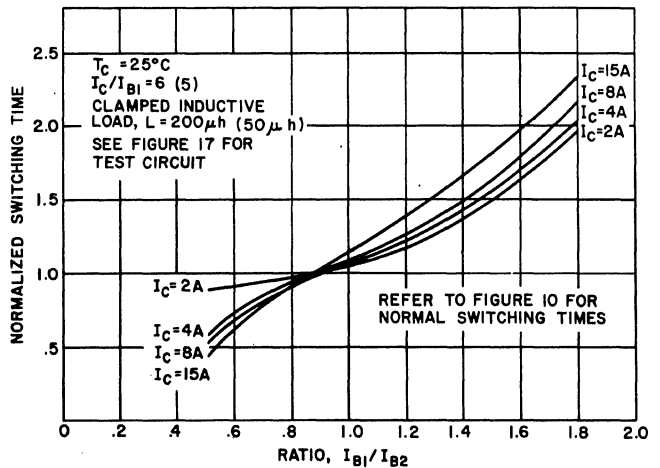

FIGURE 12. FALL TIME VARIATION WITH I_{B2}

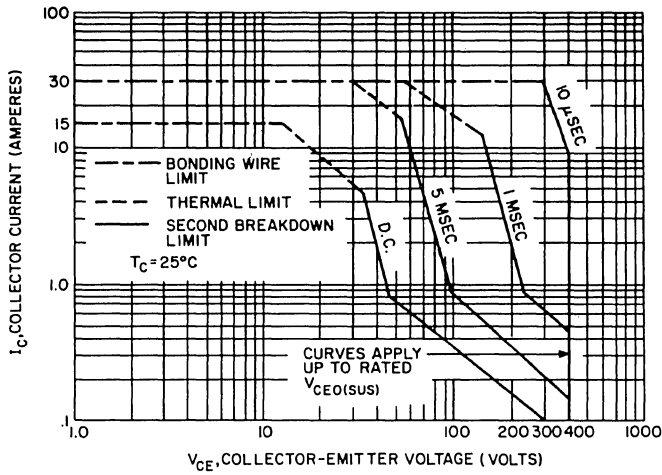

FIGURE 13. FORWARD BIAS SAFE OPERATING AREA

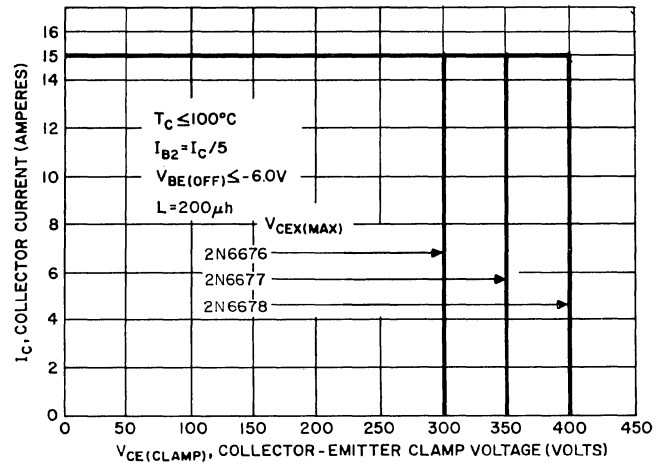

FIGURE 14. CLAMPED REVERSE BIAS SAFE OPERATING AREA

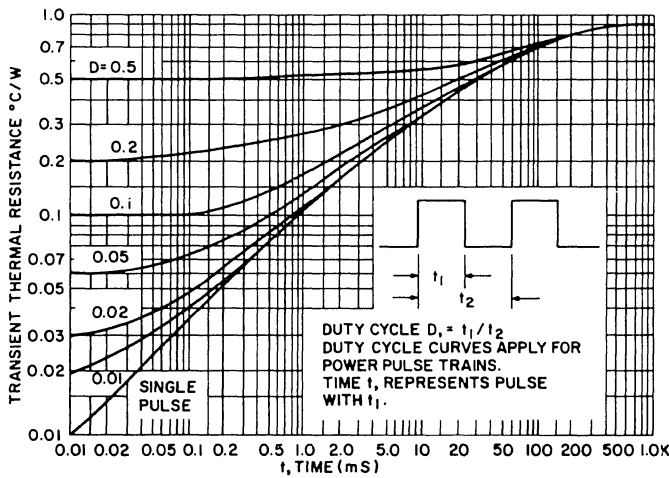

FIGURE 15. TRANSIENT THERMAL RESPONSE

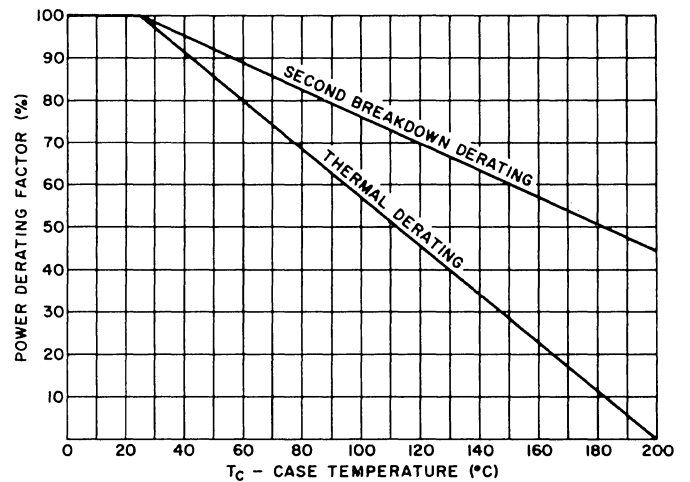

FIGURE 16. POWER DERATING

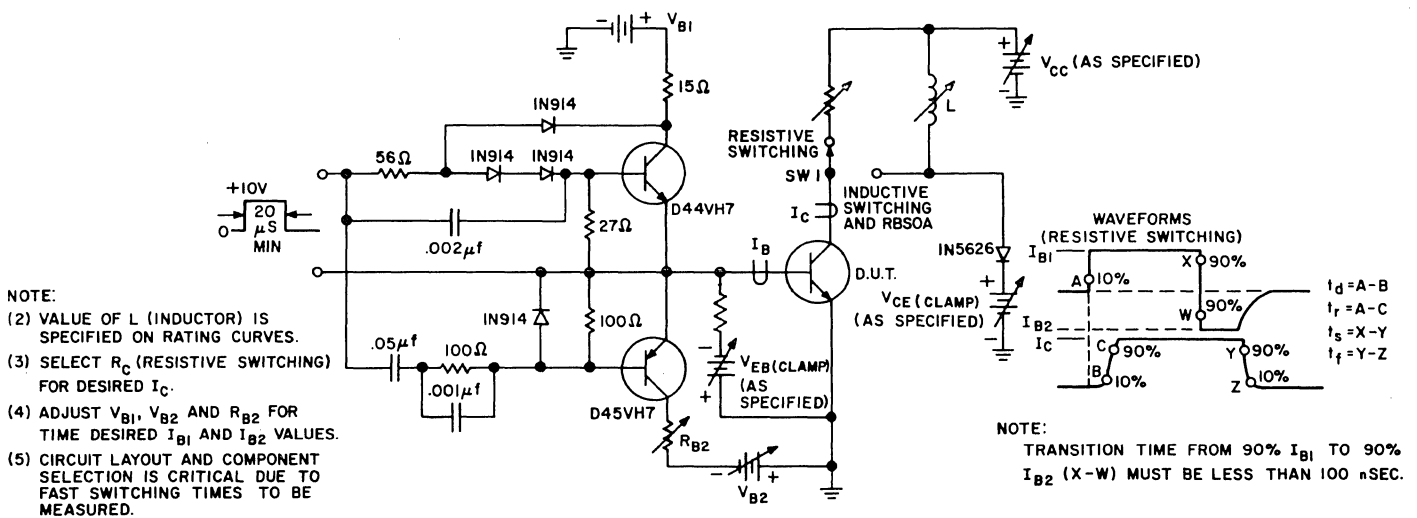

FIGURE 17. TEST CIRCUIT FOR SWITCHING TIMES AND RBSOA