

Technical Data

TRANSISTOR

maximum ratings

VDS	100.0	V	NO.	2N6901-M
VDG	100.0	V	TYPE	V-MOS
VGS	± 10.0	V		LOGIC LEVEL
ID	1.69	A		N-CHANNEL
IDM	5.0	A	CASE	TO-39
IG		A		MIL-S-19500
Max. Power Dissipation (PT) at TC = 25 °C	8.33	W		BURN-IN 48h/125°C
Max. Thermal Resistance (Rth J-C)	15.0	°C/W		
Max. Junction Temperature (TJ)	150.0	°C		

PERFORMANCE CHARACTERISTICS at $T_c = 25^\circ\text{C}$, unless otherwise noted

NO.	SYMBOL	CONDITIONS	MIN.	MAX.	UNITS
1.	BVDSS	ID = 1 mA	100.0	-	V
2.	VGS(TH)	ID = 1 mA	1.0	2.0	V
3.	IDSS	VDS = 80 V	-	1.0	μA
4.	IDSS	VDS = 80 V , TC = 125 °C	-	50.0	μA
5.	IGSS	VGS = 10 V	-	100.0	nA
6.	VDS(ON)	ID = 1.07 A , VGS = 5 V (1)	-	1.5	V
7.	VDS(ON)	ID = 1.69 A , VGS = 5 V (1)	-	2.4	V
8.	RDS(ON)	ID = 1.07 A , VGS = 5 V (1)	-	1.4	Ω
9.	RDS(ON)	ID = 1.07 A , VGS = 5 V , TC = 125 °C (1)	-	2.6	Ω
10.	Ciss	VDS = 25 V , VGS = 0 V	-	200.0	pF
11.	Coss	VDS = 25 V , VGS = 0 V	-	80.0	pF
12.	Crss	VDS = 25 V , VGS = 0 V	-	20.0	pF
13.	td(ON)	ID = 1.07 A , VDD = 50 V	-	25.0	ns
14.	tr	ID = 1.07 A , VDD = 50 V	-	45.0	ns
15.	td(OFF)	ID = 1.07 A , VDD = 50 V	-	45.0	ns
16.	tf	ID = 1.07 A , VDD = 50 V	-	80.0	ns
17.					
18.					
19.					
20.					

Notes (1)pulse-tested $t_p \leq 300 \mu\text{s}$, duty cycle $\leq 2\%$

DIMENSIONS
in mm

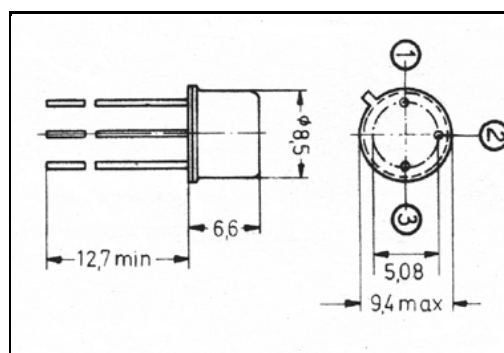

Marking 2N6901-M + GREEN DOT

Customer GENERAL PURPOSE