

INTERFACE AND SWITCHING APPLICATION.

FEATURES

- ESD Protected 2000V.(Human Body Model)
- High density cell design for low $R_{DS(ON)}$.
- Voltage controlled small signal switch.

MAXIMUM RATING (Ta=25 °C)

CHARACTERISTIC		SYMBOL	RATING	UNIT
Drain-Source Voltage		V_{DSS}	60	V
Gate-Source Voltage		V_{GSS}	± 20	V
Drain Current	Continuous	I_D	300	mA
	Pulsed (Note 1)	I_{DP}	1000	
Drain Power Dissipation (Note 2)		P_D	270	mW
Junction Temperature		T_j	150	
Storage Temperature Range		T_{stg}	-55 150	
Thermal Resistance, Junction to Ambient (Note 2)		R_{thJA}	460	/W

Note 1) Pulse Width 10 μ s, Duty Cycle 1%

Note 2) Surface Mounted on 2 × 2 FR4 Board

EQUIVALENT CIRCUIT

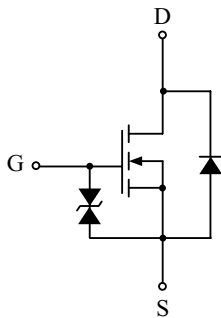

Marking

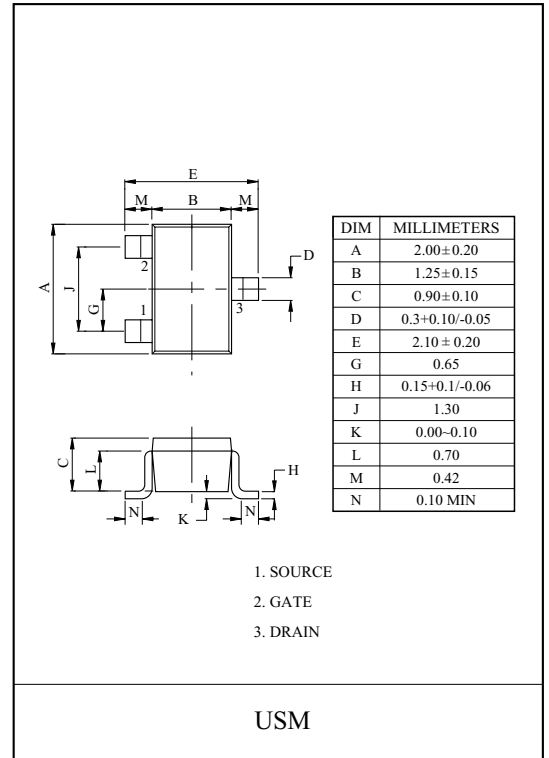
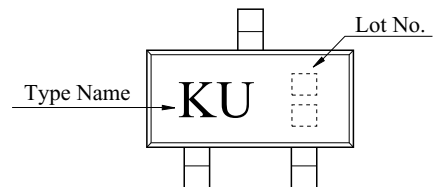

2N7002KU

ELECTRICAL CHARACTERISTICS (Ta=25 °C)

CHARACTERISTIC	SYMBOL	TEST CONDITION	MIN.	TYP.	MAX.	UNIT.	
Static							
Drain-Source Breakdown Voltage	BV_{DSS}	$V_{GS}=0V, I_D=10 \mu A$	60	-	-	V	
Zero Gate Voltage Drain Current	I_{DSS}	$V_{DS}=60V, V_{GS}=0V$	-	-	1	μA	
Gate-Body Leakage, Forward	I_{GSSF}	$V_{GS}=20V, V_{DS}=0V$	-	-	10	μA	
Gate-Body Leakage, Reverse	I_{GSSR}	$V_{GS}=-20V, V_{DS}=0V$	-	-	-10	μA	
Gate Threshold Voltage	V_{th}	$V_{DS}=V_{GS}, I_D=250 \mu A$	1.0	-	2.0	V	
Drain-Source ON Resistance	$R_{DS(ON)}$	$V_{GS}=10V, I_D=300mA$ (Note 3)	-	1.2	1.5		
		$V_{GS}=4.5V, I_D=250mA$ (Note 3)	-	1.45	1.9		
Forward Transconductance	g_{FS}	$V_{DS}=10V, I_D=300mA$	250	-	-	mS	
Drain-Source Diode Forward Voltage	V_{SD}	$V_{GS}=0V, I_S=300mA$	-	0.9	1.2	V	
Dynamic							
Input Capacitance	C_{iss}	$V_{DS}=25V, V_{GS}=0V, f=1MHz$	-	20	-	pF	
Reverse Transfer Capacitance	C_{rss}						
Output Capacitance	C_{oss}						
Switching Time	Turn-On Time	t_{on}	$V_{DD}=30V, I_D=300mA, V_{GS}=10V$ (Note 3)		-	9	ns
	Turn-Off Time	t_{off}	-	43	-		

Note 3) Pulse Test : Pulse Width 80 μs , Duty Cycle 1%

SWITCHING TIME TEST CIRCUIT

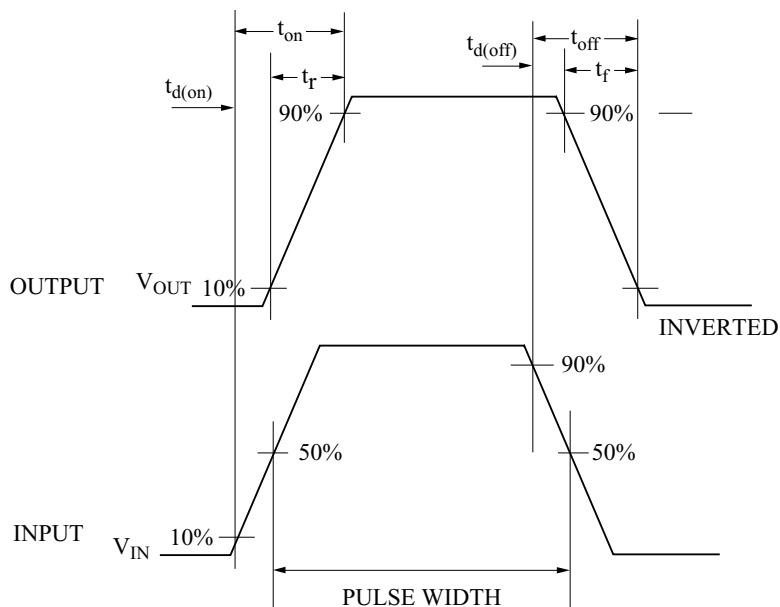
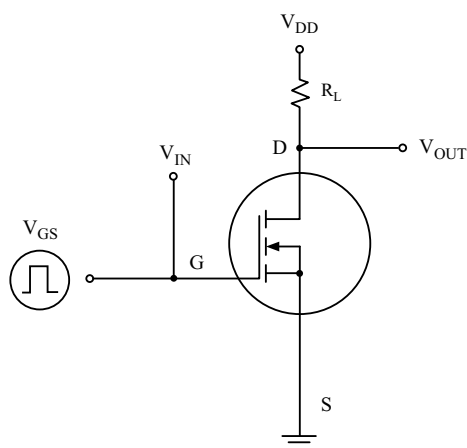

Fig 1. $I_D - V_{DS}$

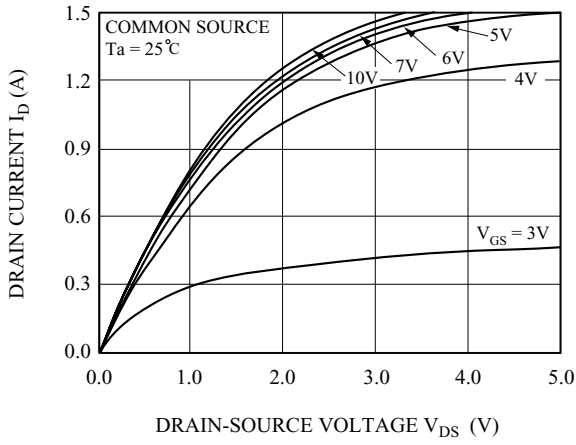

Fig 2. $R_{DS(ON)} - I_D$

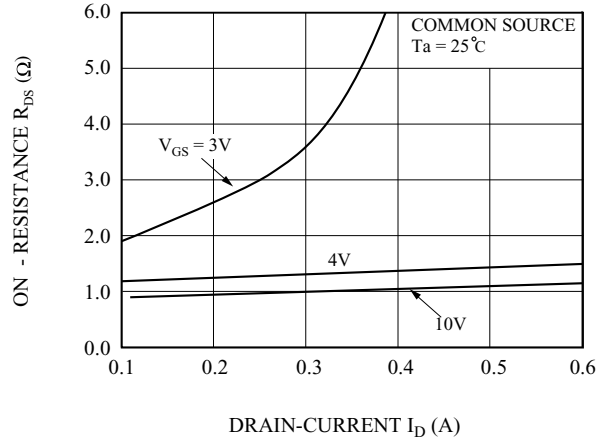

Fig 3. $R_{DS(ON)} - T_j$

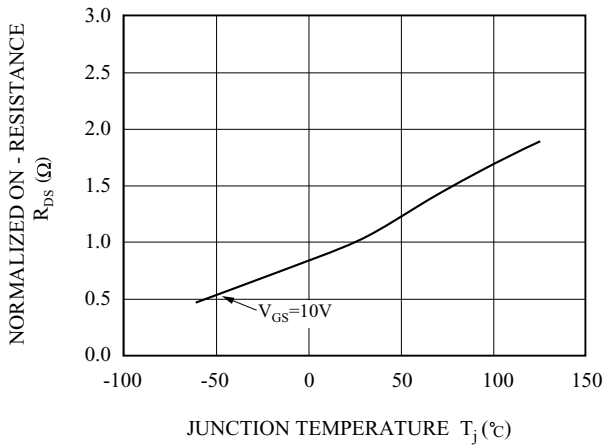

Fig 4. $V_{th} - T_j$

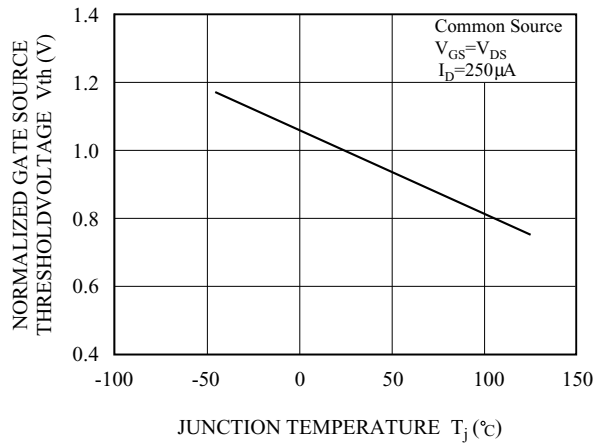

Fig 5. $I_D - V_{GS}$

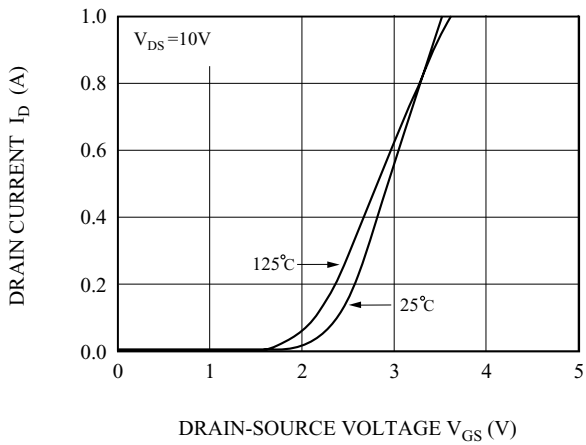
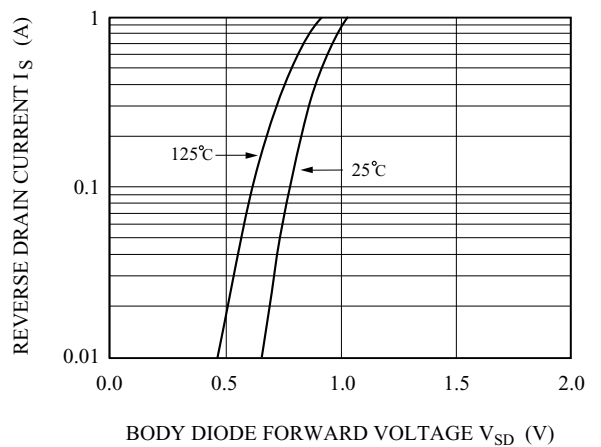

Fig 6. $I_S - V_{SD}$



2N7002KU

Fig 7. C - V_{DS}

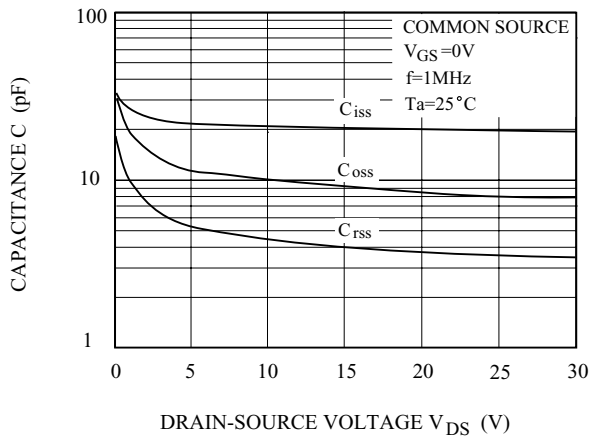

Fig 8. Safe Operation Area

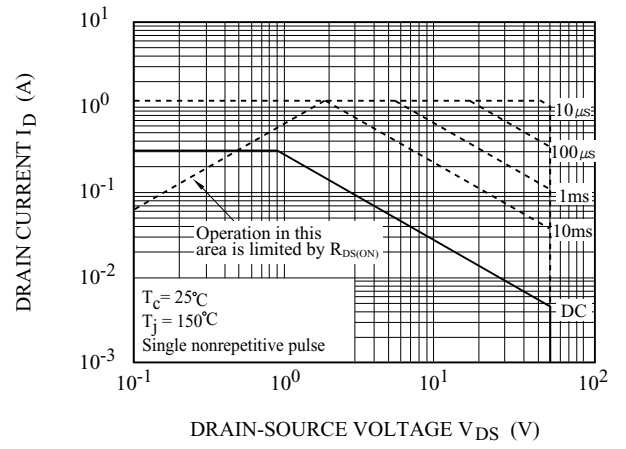

Fig 9. P_D - T_a

