



# 2N7002KW

## 60V N-Channel Enhancement Mode MOSFET - ESD Protected

### FEATURES

- $R_{DS(ON)}$ ,  $V_{GS}$  @10V,  $I_{DS}$  @500mA=3Ω
- $R_{DS(ON)}$ ,  $V_{GS}$  @4.5V,  $I_{DS}$  @200mA=4Ω
- Advanced Trench Process Technology
- High Density Cell Design For Ultra Low On-Resistance
- Very Low Leakage Current In Off Condition
- Specially Designed for Battery Operated Systems, Solid-State Relays Drivers : Relays, Displays, Lamps, Solenoids, Memories, etc.
- ESD Protected 2KV HBM
- Component are in compliance with EU RoHS 2002/95/EC directives

### MECHANICAL DATA

- Case: SOT-323 Package
- Terminals : Solderable per MIL-STD-750, Method 2026
- Marking : K72

SOT-323

Unit: inch ( mm )

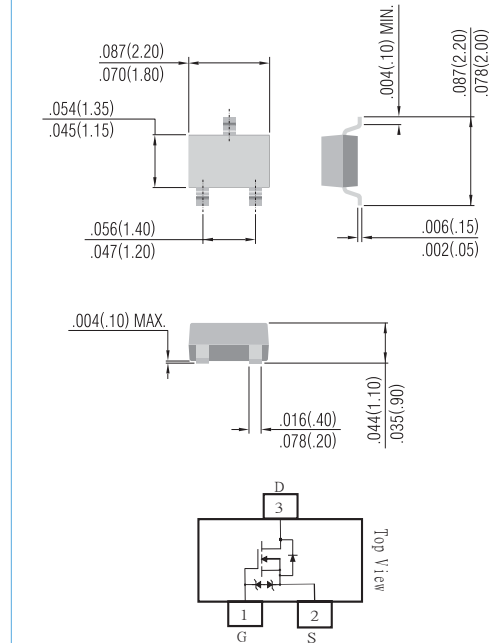

### Maximum RATINGS and Thermal Characteristics ( $T_A=25^{\circ}\text{C}$ unless otherwise noted )

PARAMETER	Symbol	Limit	Units
Drain-Source Voltage	$V_{DS}$	60	V
Gate-Source Voltage	$V_{GS}$	$\pm 20$	V
Continuous Drain Current	$I_D$	115	mA
Pulsed Drain Current <sup>1)</sup>	$I_{DM}$	800	mA
Maximum Power Dissipation	$P_D$	200 120	mW
Operating Junction and Storage Temperature Range	$T_J, T_{STG}$	-55 to + 150	$^{\circ}\text{C}$
Junction-to Ambient Thermal Resistance(PCB mounted) <sup>2</sup>	$R_{\theta JA}$	625	$^{\circ}\text{C}/\text{W}$

- Note: 1. Maximum DC current limited by the package  
2. Surface mounted on FR4 board,  $t \leq 5$  sec

**PAN JIT RESERVES THE RIGHT TO IMPROVE PRODUCT DESIGN,FUNCTIONS AND RELIABILITY WITHOUT NOTICE**



# 2N7002KW

## ELECTRICAL CHARACTERISTICS

Parameter	Symbol	Test Condition	Min.	Typ.	Max.	Units
Static						
Drain-Source Breakdown Voltage	$BV_{DSS}$	$V_{GS}=0V, I_D=10\mu A$	60	-	-	V
Gate Threshold Voltage	$V_{GS(th)}$	$V_{DS}=V_{GS}, I_D=250\mu A$	1	-	2.5	V
Drain-Source On-State Resistance	$R_{DS(on)}$	$V_{GS}=4.5V, I_D=200mA$	-	-	4.0	$\Omega$
Drain-Source On-State Resistance	$R_{DS(on)}$	$V_{GS}=10V, I_D=500mA$	-	-	3.0	
Zero Gate Voltage Drain Current	$I_{DSS}$	$V_{DS}=60V, V_{GS}=0V$	-	-	1	$\mu A$
Gate Body Leakage	$I_{GSS}$	$V_{GS}=\pm 20V, V_{DS}=0V$	-	-	$\pm 10$	$\mu A$
Forward Transconductance	$g_{fs}$	$V_{DS}=15V, I_D=250mA$	100	-	-	mS
Diode Forward Voltage	$V_{SD}$	$I_S=200mA, V_{GS}=0V$	-	0.82	1.3	V
Dynamic						
Total Gate Charge	$Q_g$	$V_{DS}=15V, I_D=200mA$ $V_{GS}=4.5V$	-	-	0.8	nC
Turn-On Delay Time	$t_{on}$	$V_{DD}=30V, R_L=150\Omega$ $I_D=200mA, V_{GEN}=10V$ $R_G=10\Omega$	-	-	20	ns
Turn-Off Delay Time	$t_{off}$		-	-	40	
Input Capacitance	$C_{iss}$	$V_{DS}=25V, V_{GS}=0V$ $f=1.0MHz$	-	-	35	pF
Output Capacitance	$C_{oss}$		-	-	10	
Reverse Transfer Capacitance	$C_{rss}$		-	-	5	

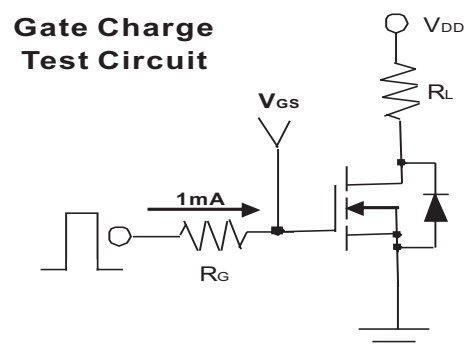
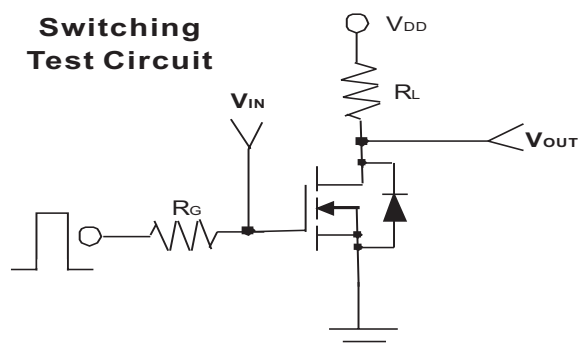



# 2N7002KW

Typical Characteristics Curves ( $T_J=25^\circ\text{C}$ , unless otherwise noted)

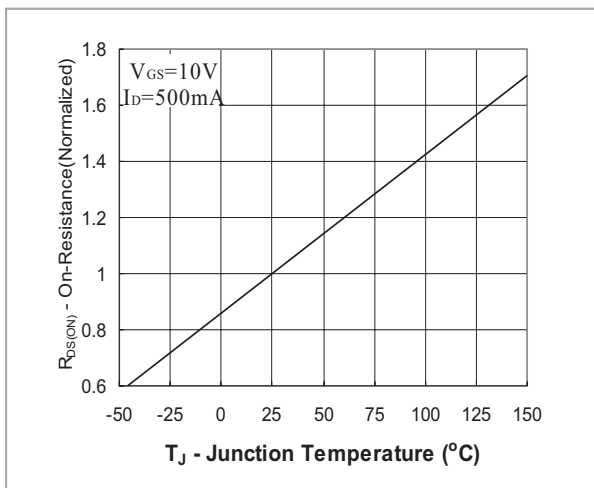
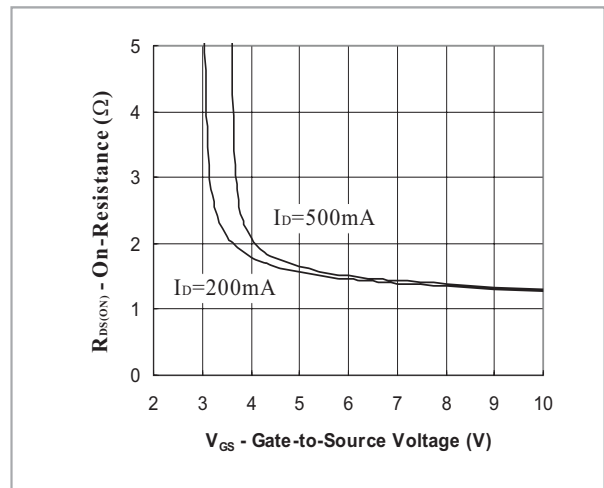
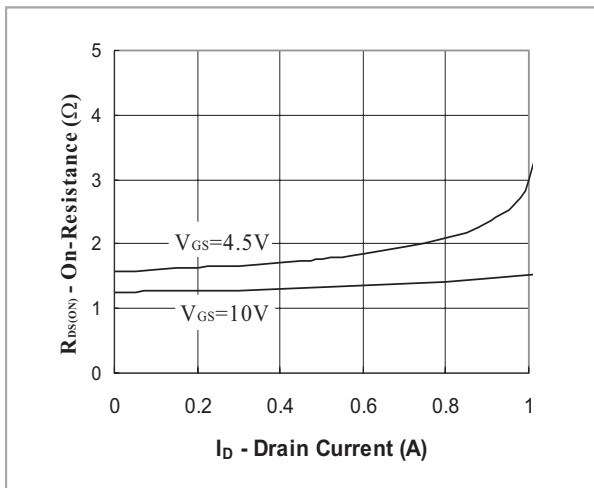
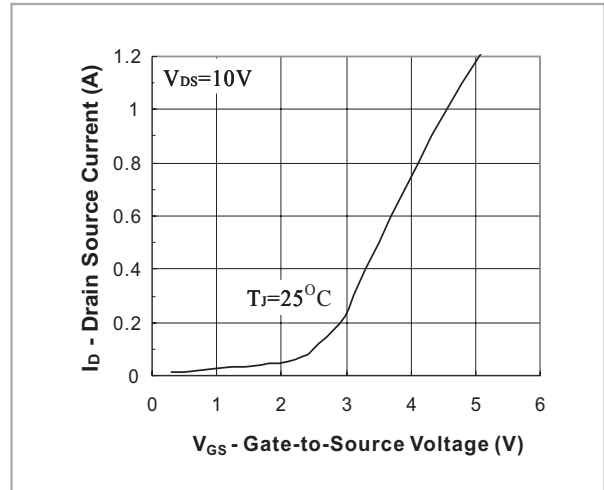
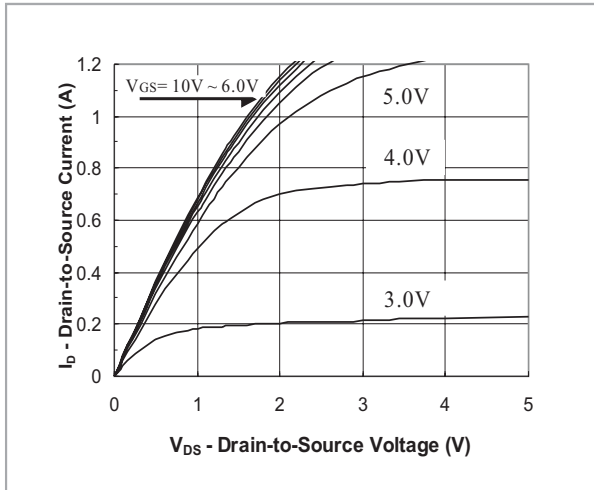



# 2N7002KW

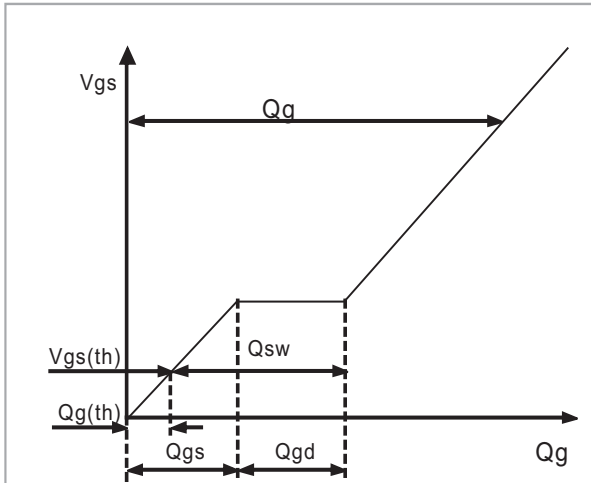

Fig. 6 - Gate Charge Waveform

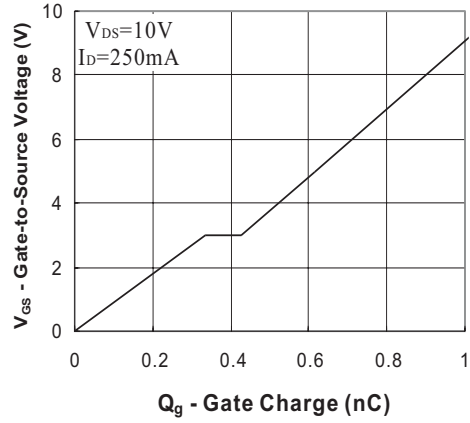

Fig. 7 - Gate Charge

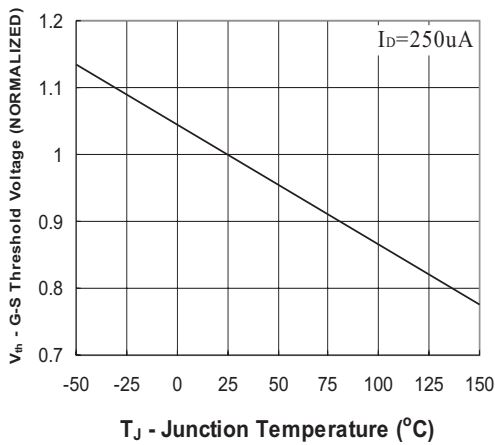

Fig. 8 - Threshold Voltage vs Temperature

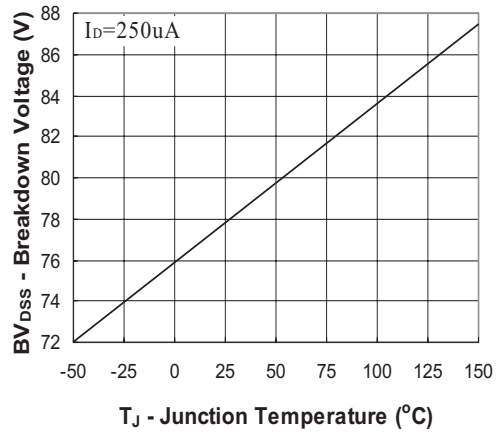

Fig. 9 - Breakdown Voltage vs Junction Temperature

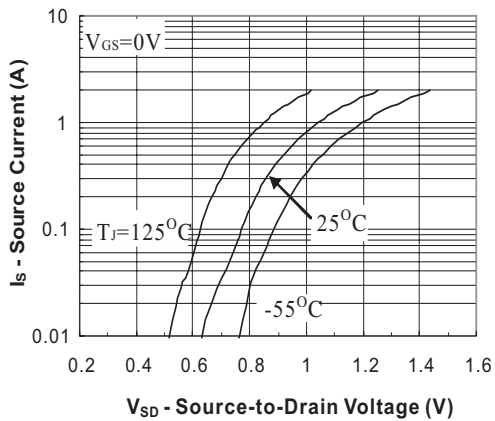

Fig.10 - Source-Drain Diode Forward Voltage



# 2N7002KW

## MOUNTING PAD LAYOUT

SOT-323

Unit: inch ( mm )

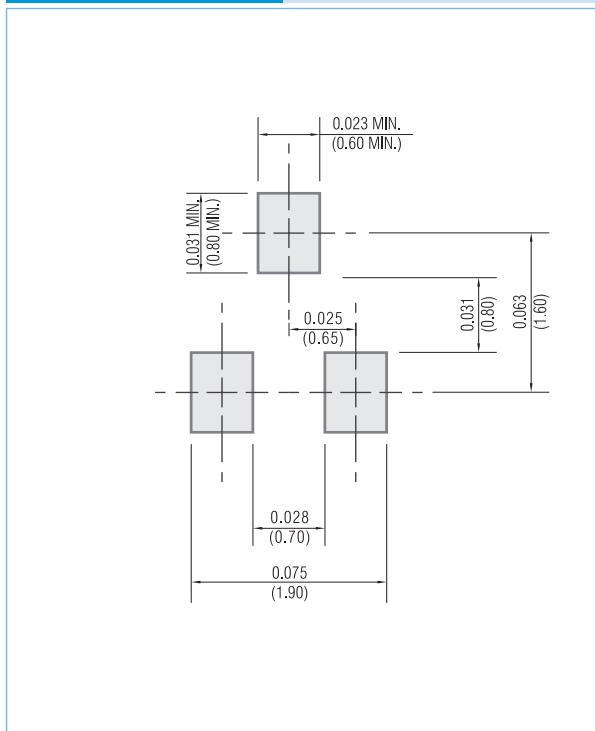

## ORDER INFORMATION

- Packing information
  - T/R - 12K per 13" plastic Reel
  - T/R - 3K per 7" plastic Reel

## LEGAL STATEMENT

### Copyright PanJit International, Inc 2007

The information presented in this document is believed to be accurate and reliable. The specifications and information herein are subject to change without notice. Pan Jit makes no warranty, representation or guarantee regarding the suitability of its products for any particular purpose. Pan Jit products are not authorized for use in life support devices or systems. Pan Jit does not convey any license under its patent rights or rights of others.