



2N90-FC

Power MOSFET

2A, 900V N-CHANNEL POWER MOSFET

DESCRIPTION

The UTC 2N90-FC provide excellent $R_{DS(ON)}$, low gate charge and operation with low gate voltages. This device is suitable for use as a load switch or in PWM applications.

FEATURES

- * $R_{DS(ON)} \leq 8.0 \Omega @ V_{GS}=10V, I_D=1.0A$
- * Low Reverse Transfer Capacitance
- * Fast Switching Capability
- * Avalanche Energy Specified
- * Improved dv/dt Capability, High Ruggedness

SYMBOL

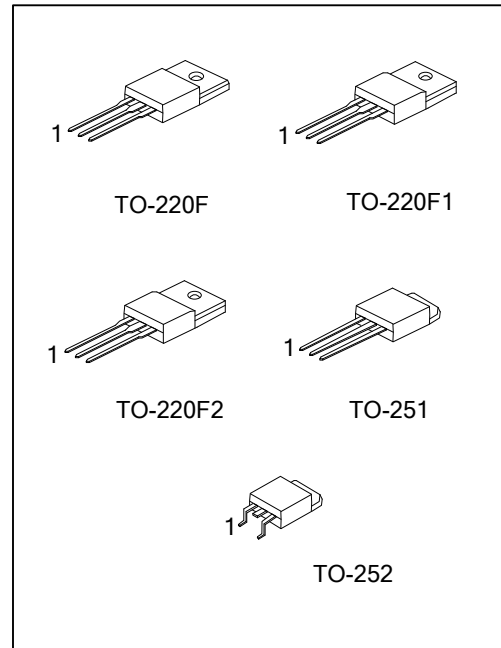
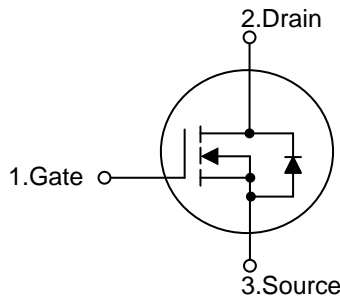

ORDERING INFORMATION

Ordering Number		Package	Pin Assignment			Packing
Lead Free	Halogen Free		1	2	3	
2N90L-TF1-T	2N90G-TF1-T	TO-220F1	G	D	S	Tube
2N90L-TF3-T	2N90G-TF3-T	TO-220F	G	D	S	Tube
2N90L-TF2-T	2N90G-TF2-T	TO-220F2	G	D	S	Tube
2N90L-TM3-T	2N90G-TM3-T	TO-251	G	D	S	Tube
2N90L-TN3-R	2N90G-TN3-R	TO-252	G	D	S	Tape Reel

Note: Pin Assignment: G: Gate D: Drain S: Source

<p>2N90G-TF1-T</p>	<p>(1) T: Tube, R: Tape Reel (2) TF1: TO-220F1, TF2: TO-220F2, TF3: TO-220F TM3: TO-251, TN3: TO-252 (3) G: Halogen Free and Lead Free, L: Lead Free</p>
--------------------	---

MARKING

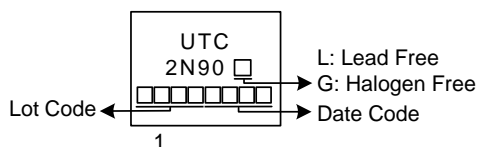

■ ABSOLUTE MAXIMUM RATINGS (T_C=25°C, unless otherwise specified)

PARAMETER		SYMBOL	RATINGS	UNIT
Drain-Source Voltage		V _{DSS}	900	V
Gate-Source Voltage		V _{GSS}	±30	V
Drain Current	Continuous	I _D	2	A
	Pulsed (Note 2)	I _{DM}	4	A
Avalanche Energy	Single Pulsed (Note 3)	E _{AS}	54	mJ
Peak Diode Recovery dv/dt (Note 4)		dv/dt	3.1	V/ns
Power Dissipation	TO-220F/TO-220F1	P _D	24	W
	TO-220F2			
	TO-251/TO-252		42	W
Junction Temperature		T _J	+150	°C
Storage Temperature		T _{STG}	-55 ~ +150	°C

- Notes: 1. Absolute maximum ratings are those values beyond which the device could be permanently damaged. Absolute maximum ratings are stress ratings only and functional device operation is not implied.
2. Repetitive Rating : Pulse width limited by maximum junction temperature.
3. L=30mH, I_{AS}=1.9A, V_{DD}=50V, R_G=25Ω, Starting T_J = 25°C
4. I_{SD}≤2.0A, di/dt≤200A/μs, V_{DD} ≤ BV_{DSS}, Starting T_J = 25°C

■ THERMAL DATA

PARAMETER		SYMBOL	RATINGS	UNIT
Junction to Ambient	TO-220F/TO-220F1	θ _{JA}	62.5	°C/W
	TO-220F2			
	TO-251/TO-252		110	°C/W
Junction to Case	TO-220F/TO-220F1	θ _{JC}	5.2	°C/W
	TO-220F2			
	TO-251/TO-252		2.97 (Note)	°C/W

Note: Device mounted on FR-4 substrate PC board, 2oz copper, with 1inch square copper plate.

■ **ELECTRICAL CHARACTERISTICS** ($T_J = 25^\circ\text{C}$, unless otherwise specified)

PARAMETER	SYMBOL	TEST CONDITIONS	MIN	TYP	MAX	UNIT
OFF CHARACTERISTICS						
Drain-Source Breakdown Voltage	BV_{DSS}	$V_{GS}=0V, I_D=250\mu A$	900			V
Drain-Source Leakage Current	I_{DSS}	$V_{DS}=900V, V_{GS}=0V$			10	μA
Gate-Source Leakage Current	I_{GSS}	$V_{GS}=\pm 30V, V_{DS}=0V$			± 100	nA
ON CHARACTERISTICS						
Gate Threshold Voltage	$V_{GS(TH)}$	$V_{DS}=V_{GS}, I_D=250\mu A$	3.0		5.0	V
Static Drain-Source On-State Resistance	$R_{DS(ON)}$	$V_{GS}=10V, I_D=1.0A$			8.0	Ω
DYNAMIC CHARACTERISTICS						
Input Capacitance	C_{ISS}	$V_{DS}=25V, V_{GS}=0V, f=1MHz$		300		pF
Output Capacitance	C_{OSS}			38		pF
Reverse Transfer Capacitance	C_{RSS}			2.1		pF
SWITCHING CHARACTERISTICS						
Total Gate Charge (Note 1)	Q_G	$V_{DS}=720V, V_{GS}=10V, I_D=2A$ $I_G=1mA$ (Note 1, 2)		6		nC
Gate-Source Charge	Q_{GS}			3		nC
Gate-Drain Charge	Q_{GD}			0.6		nC
Turn-On Delay Time (Note 1)	$t_{D(ON)}$	$V_{DD}=100V, V_{GS}=10V, I_D=2A,$ $R_G=25\Omega$ (Note 1, 2)		6		ns
Turn-On Rise Time	t_R			16		ns
Turn-Off Delay Time	$t_{D(OFF)}$			18		ns
Turn-Off Fall Time	t_F			26		ns
SOURCE- DRAIN DIODE RATINGS AND CHARACTERISTICS						
Maximum Continuous Drain-Source Diode Forward Current	I_S				2	A
Maximum Pulsed Drain-Source Diode Forward Current	I_{SM}				4	A
Drain-Source Diode Forward Voltage (Note 1)	V_{SD}	$I_S=2A, V_{GS}=0V$			1.4	V
Body Diode Reverse Recovery Time (Note 1)	t_{rr}	$I_S=2A, V_{GS}=0V,$ $dI_F/dt=100A/\mu s$		370		nS
Body Diode Reverse Recovery Charge	Q_{rr}			3.7		μC

Notes: 1. Pulse Test: Pulse width $\leq 300\mu s$, Duty cycle $\leq 2\%$.

2. Essentially independent of operating temperature.

■ TEST CIRCUITS AND WAVEFORMS

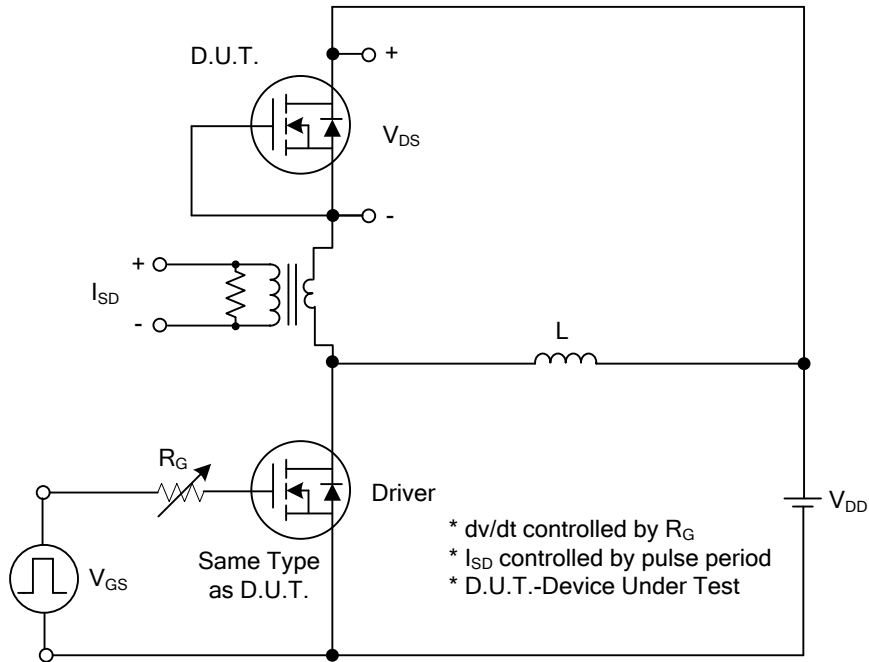

Peak Diode Recovery dv/dt Test Circuit

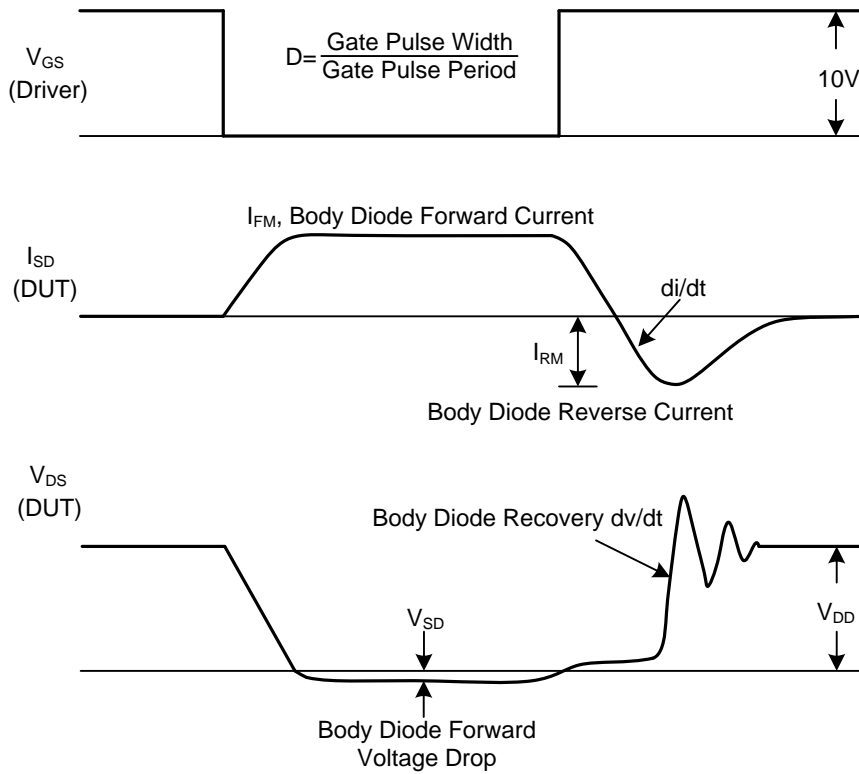

Peak Diode Recovery dv/dt Waveforms

TEST CIRCUITS AND WAVEFORMS

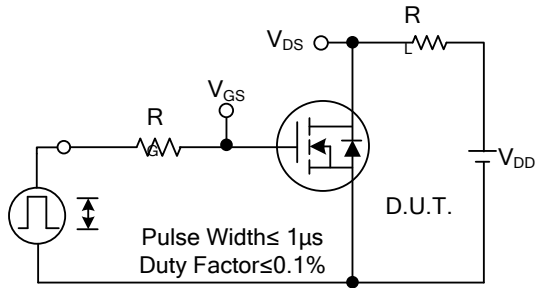

Switching Test Circuit

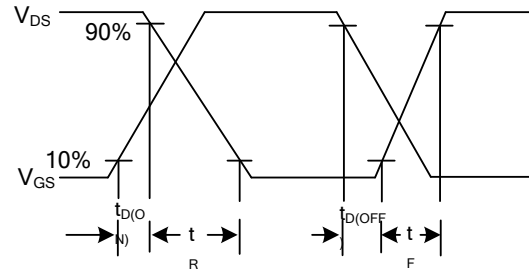

Switching Waveforms

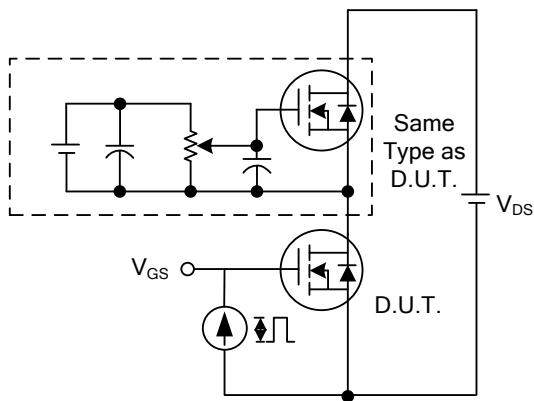

Gate Charge Test Circuit

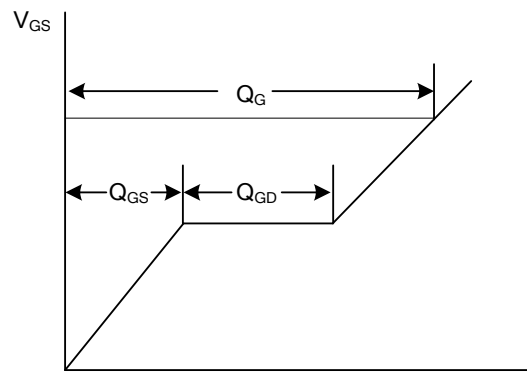

Charge

Gate Charge Waveform

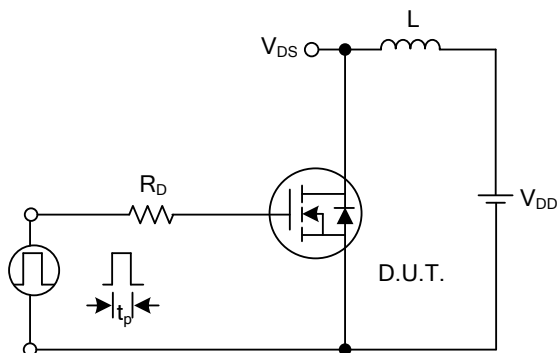

Unclamped Inductive Switching Test Circuit

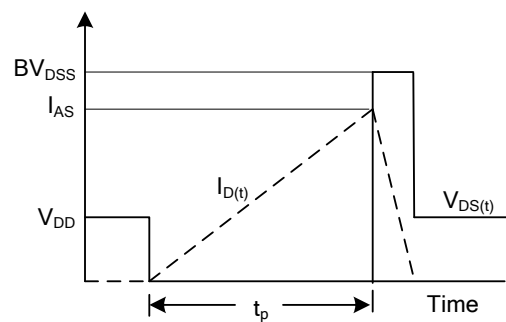

Unclamped Inductive Switching Waveforms

TYPICAL CHARACTERISTICS

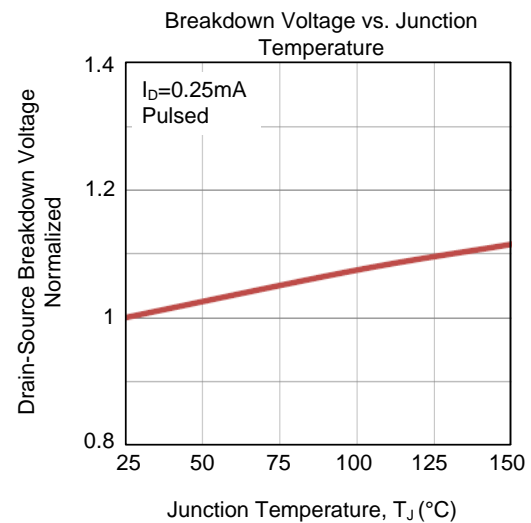
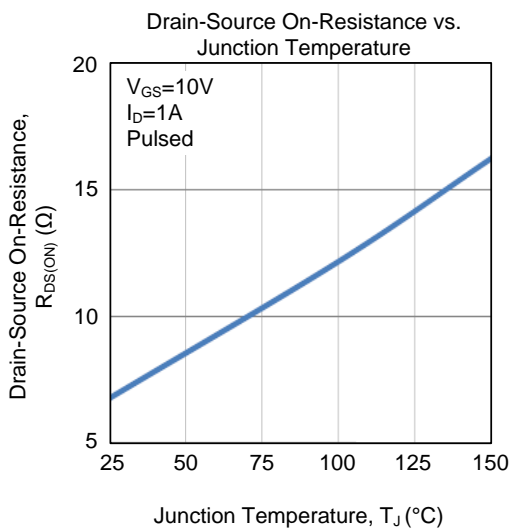
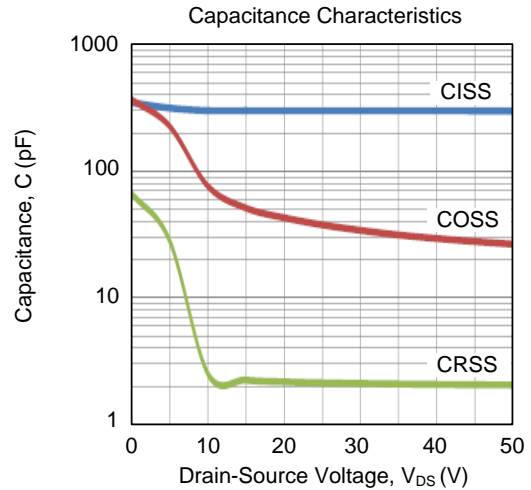
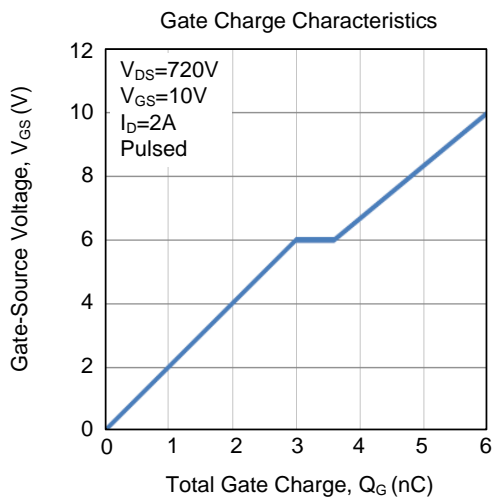
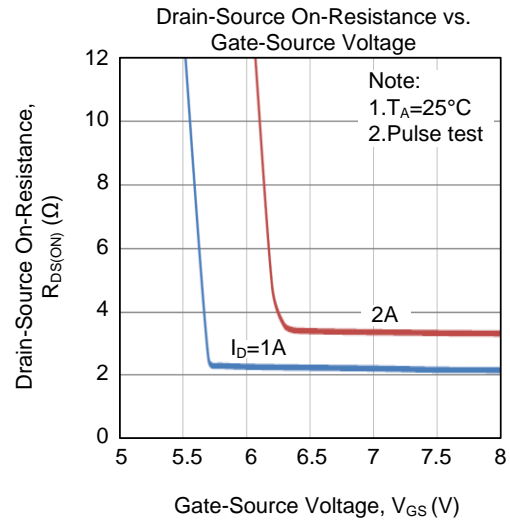
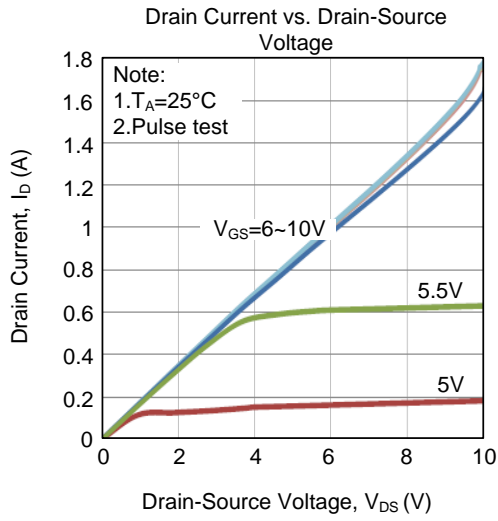

■ TYPICAL CHARACTERISTICS (Cont.)

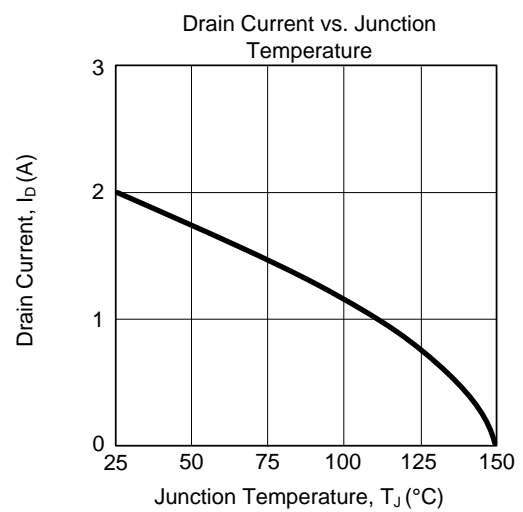
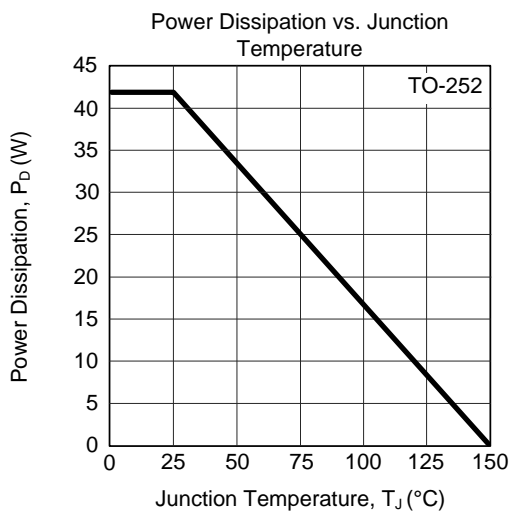
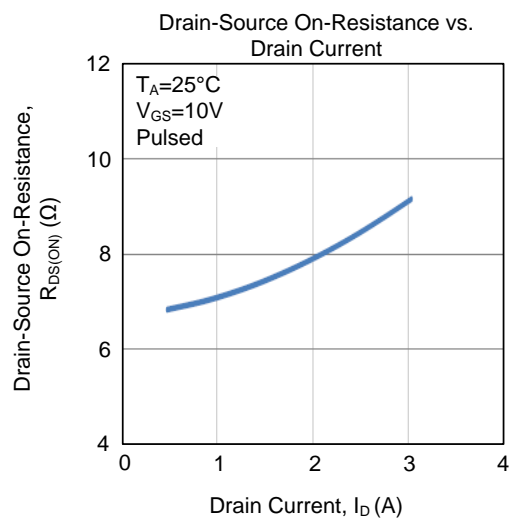
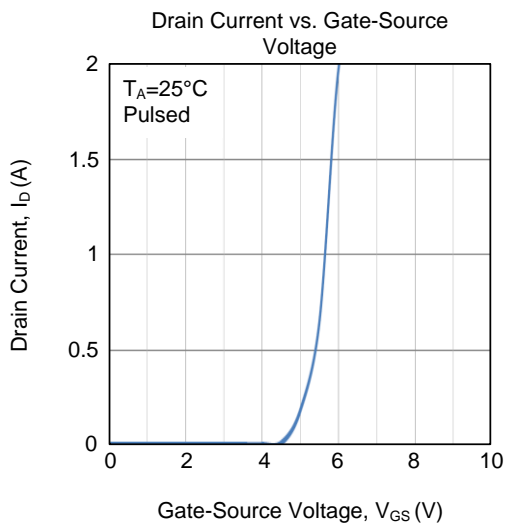
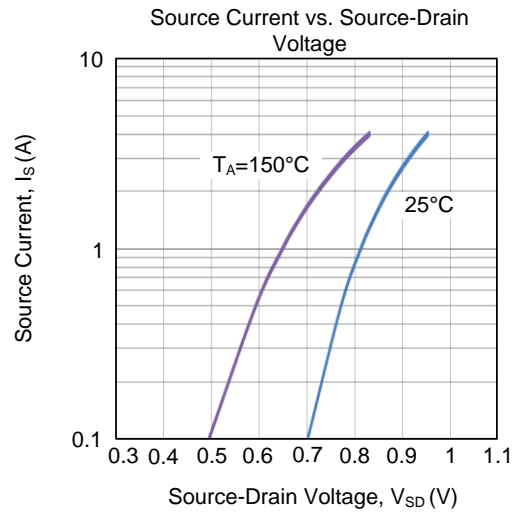
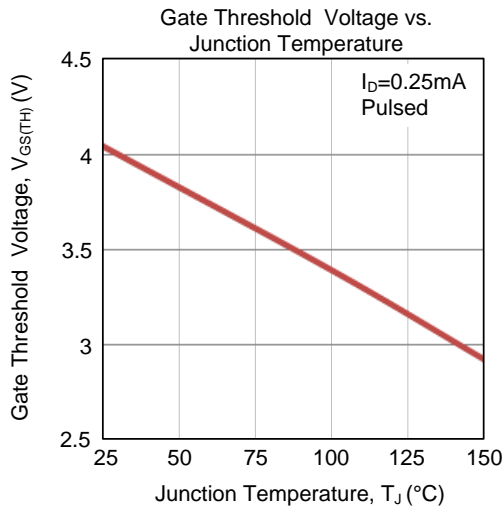

■ TYPICAL CHARACTERISTICS (Cont.)

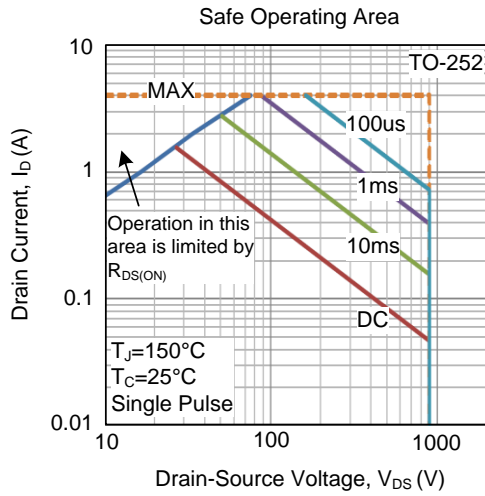

UTC assumes no responsibility for equipment failures that result from using products at values that exceed, even momentarily, rated values (such as maximum ratings, operating condition ranges, or other parameters) listed in products specifications of any and all UTC products described or contained herein. UTC products are not designed for use in life support appliances, devices or systems where malfunction of these products can be reasonably expected to result in personal injury. Reproduction in whole or in part is prohibited without the prior written consent of the copyright owner. UTC reserves the right to make changes to information published in this document, including without limitation specifications and product descriptions, at any time and without notice. This document supersedes and replaces all information supplied prior to the publication hereof.