

NPN SILICON HIGH FREQUENCY TRANSISTOR

DESCRIPTION:

The **2N918** is Designed for High Frequency Low Noise Amplifier and Oscillator Applications.

MAXIMUM RATINGS

I_C	50 mA
V_{CE}	15 V
P_{DISS}	300 mW @ $T_C = 25^\circ C$ 200 mW @ $T_C = 25^\circ C$
T_J	$-65^\circ C$ to $+200^\circ C$
T_{STG}	$-65^\circ C$ to $+200^\circ C$

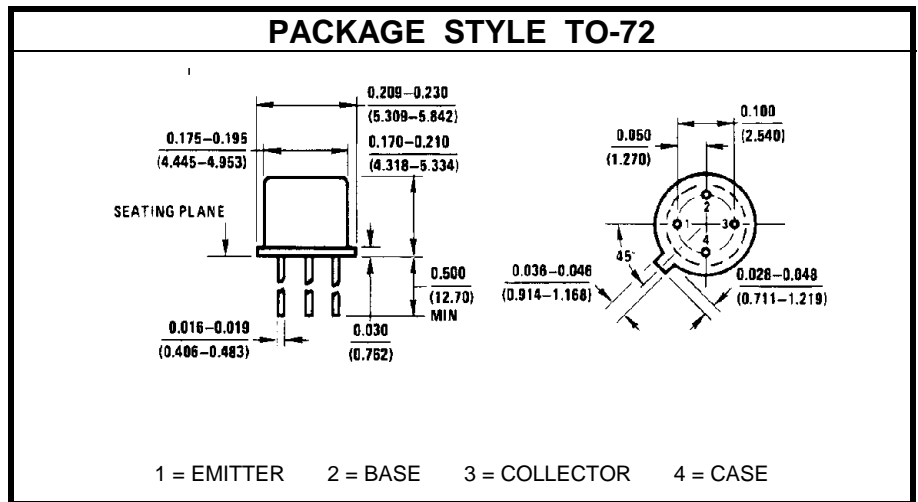
CHARACTERISTICS $T_C = 25^\circ C$

SYMBOL	TEST CONDITIONS			MINIMUM	TYPICAL	MAXIMUM	UNITS
BV_{CEO}	$I_C = 3.0 \text{ mA}$			15			V
BV_{CBO}	$I_C = 1.0 \mu A$			30			V
I_{CBO}	$V_{CB} = 15 \text{ V}$ $V_{CB} = 15 \text{ V}$	$T_A = 150^\circ C$				0.01 1.0	μA
BV_{EBO}	$I_E = 10 \mu A$			3.0			V
h_{FE}	$V_{CE} = 1.0 \text{ V}$	$I_C = 3.0 \text{ mA}$		20			---
$V_{CE(SAT)}$	$I_C = 10 \text{ mA}$	$I_B = 1.0 \text{ mA}$				0.4	V
$V_{BE(SAT)}$	$I_C = 10 \text{ mA}$	$I_B = 1.0 \text{ mA}$				1.0	V
f_t	$V_{CE} = 10 \text{ V}$	$I_C = 4.0 \text{ mA}$	$f = 100 \text{ MHz}$	600			MHz
C_{ob}	$V_{CB} = 0 \text{ V}$	$f = 140 \text{ KHz}$				3.0	pF
	$V_{CB} = 10 \text{ V}$	$f = 140 \text{ KHz}$				1.7	
C_{ib}	$V_{EB} = 0.5 \text{ V}$	$f = 140 \text{ KHz}$				2.0	pF
N_F	$V_{CE} = 6.0 \text{ V}$	$I_C = 1.0 \text{ mA}$	$f = 60 \text{ MHz}$			6.0	dB
G_{pe}	$V_{CB} = 12 \text{ V}$	$I_C = 6.0 \text{ mA}$	$f = 200 \text{ MHz}$	15			dB
P_{out} η	$V_{CB} = 15 \text{ V}$	$I_C = 8.0 \text{ mA}$	$f = 500 \text{ MHz}$	30			mW
				25			%