

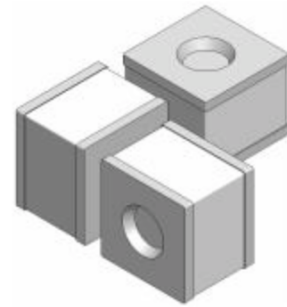

Gas Discharge Tubes-2RxxxL5050

Gas discharge tubes (GDT) use noble gasses enclosed in ceramic tubes to provide an alternate circuit path for voltage spikes. The ceramic envelope and with nickel connectors allow for high loads and SEMITECH offers products that function at 20KA, 40KA,50KA,60KA,100KA & 150KA. The breakdown voltages of the devices have a wide range (up to 20% tolerance). Major applications are high frequency telecommunication lines, stations, security systems, HID and high quality Surge Protection Devices (SPD).



Features

- RoHS & HF compliant
- Size: 5.0mm*5.0mm
- DC Spark-over voltage: 75~1000V
- Stable breakdown voltage
- High insulation resistance
- High holdover voltage
- Low Capacitance
- Large absorbing transient current capability
- Storage and operational temperature: -40°C~+85°C

Recommended Applications

- Communication equipment
- CATV equipment
- Test equipment
- Data lines
- Power supplies
- Telecom SLIC protection
- Telecommunications

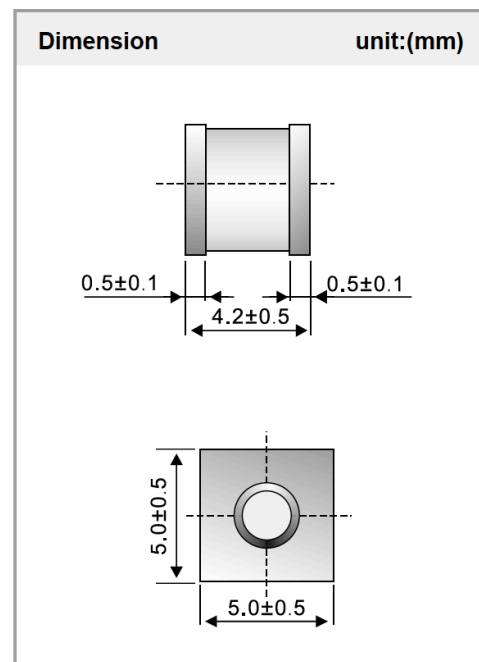

2RxxxL5050 Series

Electrical Characteristics

Part Number	DC Spark-over Voltage	Maximum Impulse Breakdown Voltage		Max. Impulse Discharge Current (8/20 μ s)		Impulse Life (10/1000 μ s)	Normal Alternating Discharge Current		DC Holdover Voltage	Minimum Insulation Resistance	Maximum Capacitance (1MHz)
	100V/S	100V/ μ s	1KV/ μ s	1 time	10 times	100A	50Hz 1Sec	Single 9 Cycles	<150ms		
	(V)	(V)	(V)	(KA)		(Times)	(A)		(V)		
2R075L5050	75 \pm 30%	600	700	8	5	300	5	15	52	1	0.8
2R090L5050	90 \pm 30%	600	700	8	5	300	5	15	52	1	0.8
2R150L5050	150 \pm 30%	500	700	8	5	300	5	15	52	1	0.8
2R230L5050	230 \pm 30%	500	650	8	5	300	5	15	80	1	0.8
2R250L5050	250 \pm 30%	500	650	8	5	300	5	15	135	1	0.8
2R300L5050	300 \pm 30%	550	700	8	5	300	5	15	135	1	0.8
2R350L5050	350 \pm 30%	600	750	8	5	300	5	15	135	1	0.8
2R400L5050	400 \pm 30%	650	800	8	5	300	5	15	135	1	0.8
2R420L5050	420 \pm 30%	650	850	8	5	300	5	15	135	1	0.8
2R470L5050	470 \pm 30%	750	900	8	5	300	5	15	135	1	0.8
2R600L5050	600 \pm 30%	900	1000	8	5	300	5	15	135	1	0.8
2R800L5050	800 \pm 30%	1000	1100	8	5	300	5	15	135	1	0.8
2R1000L5050	1000 \pm 30	1500	1600	8	5	300	5	15	135	1	0.8

Soldering parameters reflow soldering (surface mount devices)

Reflow Condition		Pb – Free assembly
Pre Heat	- Temperature Min ($T_{s(min)}$)	150°C
	- Temperature Max ($T_{s(max)}$)	200°C
	- Time (Min to Max) (t_s)	60 – 180 secs
Average ramp up rate (Liquidus Temp (T_L) to peak)		3°C/second max
$T_{s(max)}$ to T_L - Ramp-up Rate		5°C/second max
Reflow	- Temperature (T_L) (Liquidus)	217°C
	- Temperature (t_L)	60 – 150 seconds
Peak Temperature (T_p)		260 ^{+0/-5} °C
Time within 5°C of actual peak Temperature (t_p)		10 – 30 seconds
Ramp-down Rate		6°C/second max
Time 25°C to peak Temperature (T_p)		8minutes Max.
Do not exceed		260°C

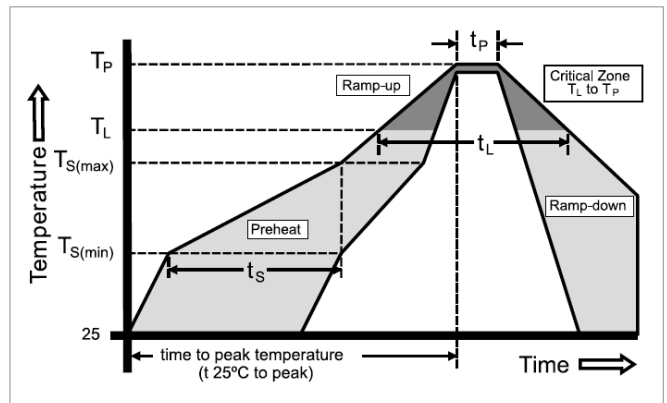

Soldering parameters – wave soldering

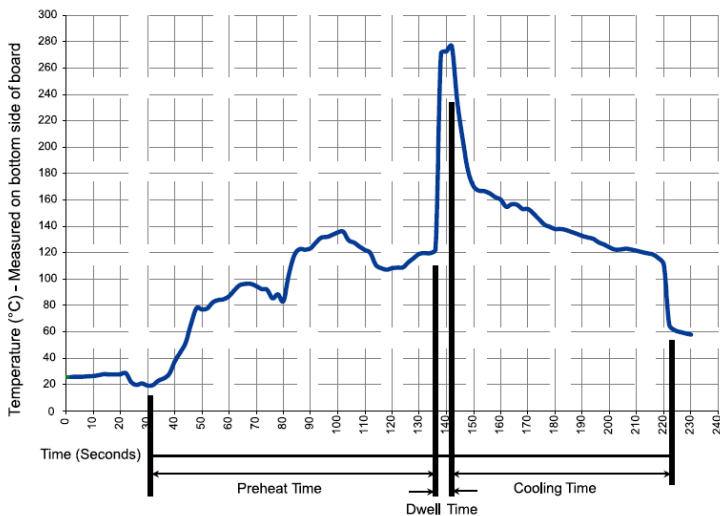

Recommended process parameters

Wave Parameter	Lead-Free Recommendation
Preheat: (Depends on Flux Activation Temperature)	(Typical Industry Recommendation)
Temperature Minimum:	100° C
Temperature Maximum:	150° C
Preheat Time:	60-180 seconds
Solder Pot Temperature:	280° C Maximum
Solder Dwell Time:	2-5 seconds