

DATA SHEET

GAS DISCHARGE TUBE – 2R-5 SERIES

FEATURES

- ✧ Provide ultra-fast response to surge voltage from slow-rising surge of 100V/s to rapid-rising surge of 1KV/μs.
- ✧ Stable breakdown voltage.
- ✧ High insulation resistance.
- ✧ Low capacitance (≤1.5pF).
- ✧ High holdover voltage.
- ✧ Large absorbing transient current capability.
- ✧ Micro-Gap Design
- ✧ Size:5.5mm*6mm
- ✧ Storage and operational temperature: -40°C ~ +85°C
- ✧ Meets MSL level 1, per J -STD-020

APPLICATION

- ✧ Repeaters, Modems.
- ✧ Telephone Interface, Line cards.
- ✧ Data communication equipment.
- ✧ Line test equipment.

PART NUMBER CODE

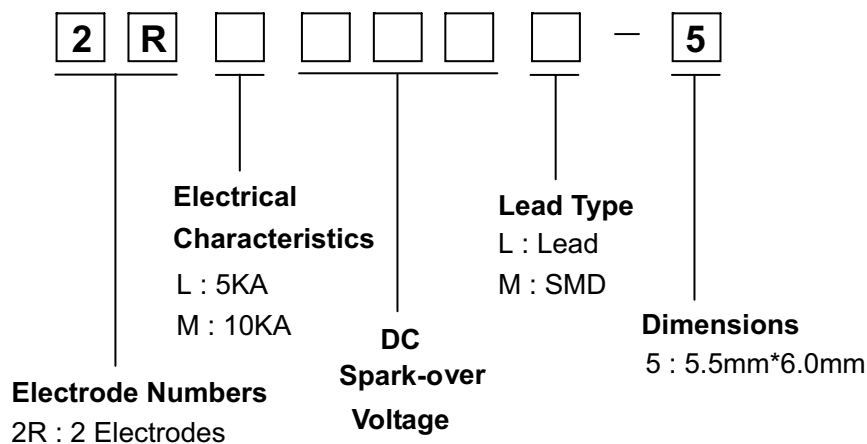

DIMENSIONS

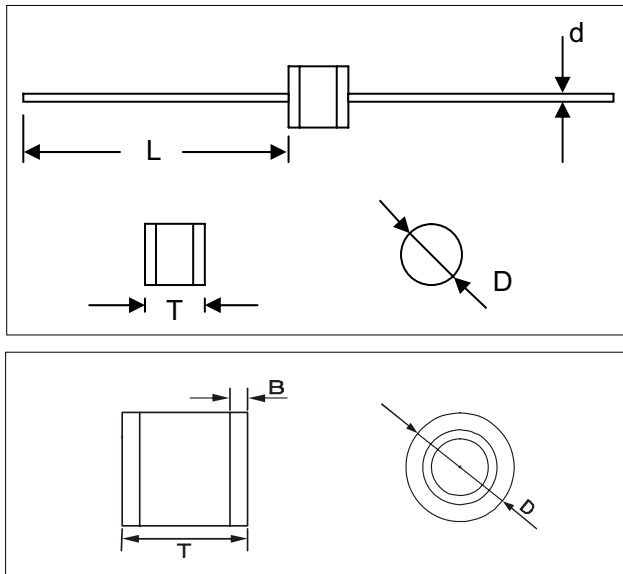

unit :mm

Items	Dimension	
	Spec.	Tolerance
D	5.5	+0.3,-0.5
T	6.0	+0.3,-0.5
d	0.8	±0.1
L	30.0	Max.
D	5.5	+0.3,-0.5
T	6.0	+0.3,-0.5
B	1.1	±0.4

ELECTRICAL CHARACTERISTIC

Part Number		DC Spark-over Voltage	Maximum Impulse Spark-over Voltage	Nominal Impulse Discharge Current	Alternating Discharge Current	Impulse Life	Minimum Insulation Resistance		Maximum Capacitance	Device Marking Code
							Test Voltage	(GΩ)		
2RL070L-5	2RL070M-5	70±20%	800	5.0	5.0	300	25	1.0	1.5	2RL070-5
2RL075L-5	2RL075M-5	75±20%	800	5.0	5.0	300	25	1.0	1.5	2RL075-5
2RL090L-5	2RL090M-5	90±20%	700	5.0	5.0	300	50	1.0	1.5	2RL090-5
2RL145L-5	2RL145M-5	145±20%	700	5.0	5.0	300	100	1.0	1.5	2RL145-5
2RL150L-5	2RL150M-5	150±20%	700	5.0	5.0	300	100	1.0	1.5	2RL150-5
2RL230L-5	2RL230M-5	230±20%	700	5.0	5.0	300	100	1.0	1.5	2RL230-5
2RL250L-5	2RL250M-5	250±20%	700	5.0	5.0	300	100	1.0	1.5	2RL250-5
2RL300L-5	2RL300M-5	300±20%	900	5.0	5.0	300	100	1.0	1.5	2RL300-5
2RL350L-5	2RL350M-5	350±20%	900	5.0	5.0	300	100	1.0	1.5	2RL350-5
2RL400L-5	2RL400M-5	400±20%	1000	5.0	5.0	300	100	1.0	1.5	2RL400-5
2RL470L-5	2RL470M-5	470±20%	1100	5.0	5.0	300	250	1.0	1.5	2RL470-5
2RL600L-5	2RL600M-5	600±20%	1500	5.0	5.0	300	250	1.0	1.5	2RL600-5
2RL800L-5	2RL800M-5	800±20%	1700	5.0	5.0	300	250	1.0	1.5	2RL800-5
2RM070L-5	2RM070M-5	70±20%	600	10	5.0	500	25	1.0	1.5	2RM070-5
2RM075L-5	2RM075M-5	75±20%	600	10	5.0	500	25	1.0	1.5	2RM075-5
2RM090L-5	2RM090M-5	90±20%	600	10	10	500	50	1.0	1.5	2RM090-5
2RM145L-5	2RM145M-5	145±20%	700	10	10	500	100	1.0	1.5	2RM145-5
2RM150L-5	2RM150M-5	150±20%	700	10	10	500	100	1.0	1.5	2RM150-5
2RM230L-5	2RM230M-5	230±20%	700	10	10	500	100	1.0	1.5	2RM230-5
2RM250L-5	2RM250M-5	250±20%	700	10	10	500	100	1.0	1.5	2RM250-5
2RM300L-5	2RM300M-5	300±20%	900	10	10	500	100	1.0	1.5	2RM300-5
2RM350L-5	2RM350M-5	350±20%	900	10	10	500	100	1.0	1.5	2RM350-5
2RM400L-5	2RM400M-5	400±20%	1000	10	10	500	100	1.0	1.5	2RM400-5
2RM470L-5	2RM470M-5	470±20%	1200	10	10	500	250	1.0	1.5	2RM470-5
2RM600L-5	2RM600M-5	600±20%	1300	10	10	500	250	1.0	1.5	2RM600-5
2RM800L-5	2RM800M-5	800±20%	1500	10	10	500	250	1.0	1.5	2RM800-5

ELECTRICAL RATING

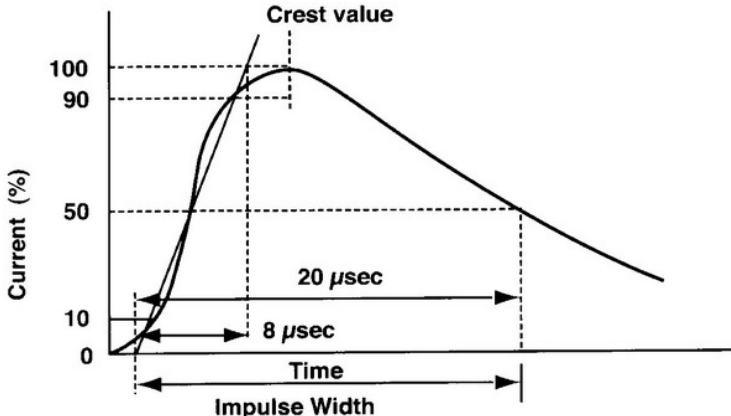
Item	Test Condition / Description	Requirement
DC Spark-over Voltage	The voltage is measured with a low rate of rise $dv / dt=100V/s$	
Maximum Impulse Spark-over Voltage	The maximum impulse breakdown voltage is measured with a rise time of $dv / dt=1000V/\mu s$	
Impulse Discharge Current	<p>The maximum current applying a waveform of 8/20μs that can be applied across the terminals of the gas tube without causing the gas tube to change more than $\pm 25\%$ from its initial measured DC breakdown voltage. Dwell time between pulses is 3 minutes.</p>  <p>The graph shows a current waveform starting at 0% and rising to a peak of 100% (labeled 'Crest value'). The rise time is 8 μs (from 10% to 90% of the peak). The total width of the pulse is 20 μs. The y-axis is labeled 'Current (%)' with marks at 0, 10, 50, 90, and 100. The x-axis is labeled 'Time' and 'Impulse Width'.</p>	To meet the specified value
Alternating Discharge Current	<p>Rated RMS value of AC current at 50Hz, 1 sec. 10 times. Intervals: 3min. DC breakdown voltage may not change more than $\pm 25\%$ from its initial measured DC breakdown voltage. $IR > 10^8$ ohms (-20%, +30% for 70 – 90V).</p>	
Insulation Resistance	The resistance of gas tube shall be measured each terminal each other terminal. please see above spec	
Capacitance	<p>The capacitance of gas tube shall be measured each terminal to each other terminal. Test frequency :1MHz</p>	